

GE
Measurement & Control

RHM 015

Ultimate Low Flow Coriolis Mass Flowmeter

The RHM 015 can reliably measure flow rates as low as 1.5 g/min (0.003 lb/min). With its extremely wide turn-down ratio of 300 to 1, this model is perfect for laboratory and test applications. A true low flow sensor, manufactured by GE's Rheonik mass flowmeter experts.

Applications

- General control
- Dosing
- Mixing
- Batching
- Injections
- Filling

Features

- Suitable for pressure up to 700 bar
- Flow uncertainty down to 0.10%
- Repeatability better than 0.05%
- Unique torsion oscillator
- Typical measuring ranges from 4 to 600 g/min
- Minimal flows as low as 1.5 g/min
- Extra compact design with minimal space requirement
- Hazardous Area Approvals (ATEX, CSA, ...)
- Customization possible



Advantages

- Torsion oscillator design assures most stable and basically drift free measurement and increased signal to noise ratio
- Not sensitive to changes in pressure
- Longest life time and increased safety (low stress in welds and increased wall thickness against abrasion)
- No moving parts, practically no maintenance
- Removable connection manifold available



Reading Office

Cutbush Park, Danehill, Lower Earley,
Reading, Berkshire. RG6 4UT. UK.
Tel: +44 (0)118 9311188
Email: info@able.co.uk

Aberdeen Office

Unit 6 Airside Business Park, Kirkhill Industrial Estate,
Dyce, Aberdeen. AB21 0GT. UK.
Tel: +44 (0)1224 725999
Email: ab@able.co.uk

Internet: www.able.co.uk
e-procurement: www.247able.com
Registered in England No: 01851002
VAT No: GB 417 2481 61



General Dimensions RHM 015

PM0/SM0 (parallel/serial, manifold construction)

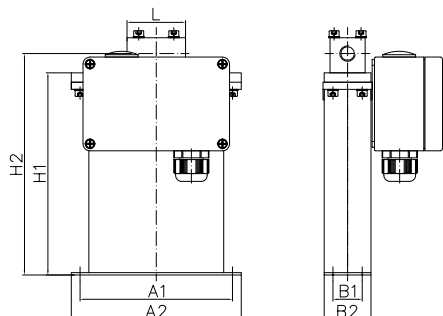

Type removable manifold with PTFE seals and thread connection
H2 = 189 mm (7.44 in)

	Process Connection	Face to face length (L)		Order Code
		mm	in	
Standard	Female Thread G 1/4"	50	1.97	G1
	Female Thread 1/4" NPT	50	1.97	N1

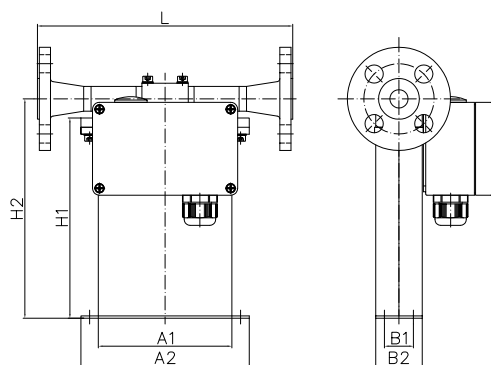

Type removable manifold with PTFE seals and flange connection
H2 = 189 mm (7.44 in)

	Process Connection	Face to face length (L)		Order Code
		mm	in	
Standard	Flange DIN DN15/PN40	220	8.66	D1
	Flange DIN DN15/PN100	220	8.66	D2
	Flange ANSI 1/2" 150# RF/SF	220	8.66	A1
	Flange ANSI 1/2" 300# RF/SF	220	8.66	A2
	Flange ANSI 1/2" 600# RF/SF	220	8.66	A3
	Flange ANSI 1/2" 1500# RF/SF	300	11.81	A6
Optional	Flange ANSI 1/2" 1500# RTJ	300	11.81	R1
	Flange DIN DN15/PN160	220	8.66	D3
	Flange JIS RF 10k 15A (1/2")	220	8.66	J1
	Flange JIS RF 20k 15A (1/2")	220	8.66	J2

PH0/SH0 (parallel/serial, high pressure manifold construction)

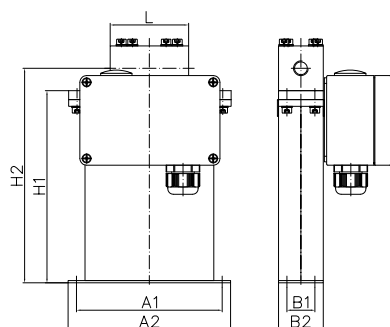

Type high pressure manifold with PTFE seals and thread connection
H2 = 193 mm (7.58 in)

A1 = 130 mm (5.12 in)
A2 = 145 mm (5.71 in)
H1 = 173 mm (6.79 in)

B1 = 25 mm (0.98 in)
B2 = 40 mm (1.57 in)

	Process Connection	Face to face length (L)		Order Code
		mm	in	
Standard	Female Thread G 1/4"	70	2.76	G1
	Female Thread 1/4" NPT	70	2.76	N1
	Autoclave 3/8" MP (9/16-18 UNF female thread)	70	2.76	P2

Terminal box (without cable gland) 125 x 80 x 58 mm (4.92 x 3.15 x 2.28 in)

No terminal box, 2 m free PTFE cable ends for Temperature Range T2

For weights and packaging dimensions please see last page of this section.

Reading Office

Cutbush Park, Danehill, Lower Earley,
Reading, Berkshire. RG6 4UT. UK.
Tel: +44 (0)118 9311188
Email: info@able.co.uk

Aberdeen Office

Unit 6 Airside Business Park, Kirkhill Industrial Estate,
Dyce, Aberdeen. AB21 0GT. UK.
Tel: +44 (0)1224 725999
Email: ab@able.co.uk

Internet: www.able.co.uk
e-procurement: www.247able.com
Registered in England No: 01851002
VAT No: GB 417 2481 61



General Dimensions RHM 015

PFO (parallel, sealless construction with flange connection)

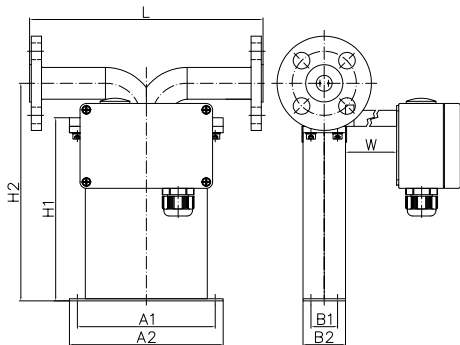

Type welded measuring loops without seals and flange connection

	Process Connection	Face to face length (L)		Order Code
		mm	in	
Standard	Flange DIN DN15/PN40	220	8.66	D1
	Flange DIN DN15/PN100	220	8.66	D2
	Flange ANSI 1/2" 150# RF/SF	220	8.66	A1
	Flange ANSI 1/2" 300# RF/SF	220	8.66	A2
	Flange ANSI 1/2" 600# RF/SF	220	8.66	A3
	Flange ANSI 1/2" 1500# RF/SF	300	11.81	A6
	Flange ANSI 1/2" 1500# RTJ	300	11.81	R1
	Flange ANSI 1/2" 2500 RF/SF	300	11.81	A8
	Flange ANSI 1/2" 2500# RTJ	300	11.81	R2
Optional	Flange DIN DN15/PN160	220	8.66	D3
	Flange JIS RF 10k 15A (1/2")	220	8.66	J1
	Flange JIS RF 20k 15A (1/2")	220	8.66	J2
	Grayloc Hub 1 GR 4 (1")	300	11.81	H3

PFT/SFT (parallel/serial, sealless construction with thread connection)

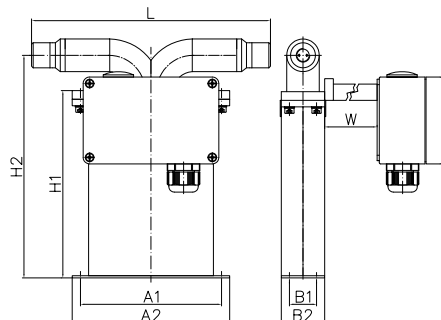

Type welded measuring loops without seals and thread connection

	Process Connection	Face to face length (L)		Order Code
		mm	in	
Standard	Female Thread G 1/4"	220	8.66	G1
	Female Thread 1/4" NPT	220	8.66	N1
	Swagelok 1/4" tube inlet (SS-400-1-4W)	300	11.81	W1

A1 = 130 mm (5.12 in)
A2 = 145 mm (5.71 in)
H1 = 173 mm (6.79 in)
H2 = 205 mm (8.07 in)

B1 = 25 mm (0.98 in)
B2 = 40 mm (1.57 in)

Terminal box (without cable gland) 125 x 80 x 58 mm (4.92 x 3.15 x 2.28 in)
W = 0 mm for Temperature Range T1 and TA
W = 100 mm (3.94 in) for Temperature Range T4

No terminal box, 2 m free PTFE cable ends for Temperature Range T2 and T3

For weights and packaging dimensions please see last page of this section.

Reading Office

Cutbush Park, Danehill, Lower Earley,
Reading, Berkshire. RG6 4UT. UK.
Tel: +44 (0)118 9311188
Email: info@able.co.uk

Aberdeen Office

Unit 6 Airside Business Park, Kirkhill Industrial Estate,
Dyce, Aberdeen. AB21 0GT. UK.
Tel: +44 (0)1224 725999
Email: ab@able.co.uk

Internet: www.able.co.uk
e-procurement: www.247able.com
Registered in England No: 01851002
VAT No: GB 417 2481 61



General Dimensions RHM 015

SFO (serial, sealless construction without dead spaces)

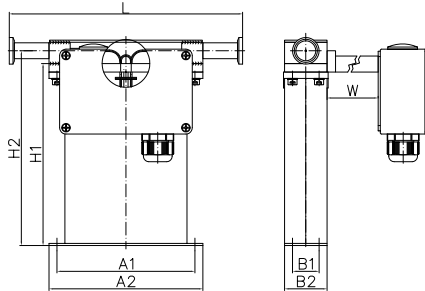

	Process Connection	Face to face length (L)		Order Code
		mm	in	
Standard	Sanitary 1/2" Triclamp DIN 32676	220	8.66	S1
	Sanitary NW10, DIN 11851	220	8.66	S2

Type welded, single path measuring loops without seals and sanitary connection
H2 = 184 mm (7.22 in)

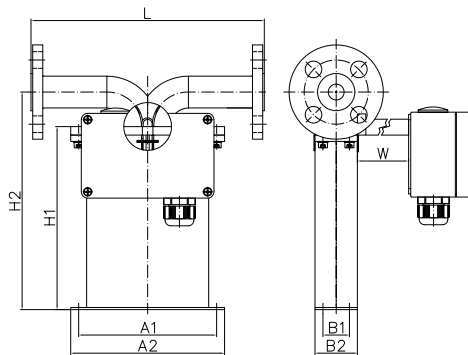

	Process Connection	Face to face length (L)		Order Code
		mm	in	
Standard	Flange DIN DN15/PN40	220	8.66	D1
	Flange DIN DN15/PN100	220	8.66	D2
	Flange ANSI 1/2" 150# RF/SF	220	8.66	A1
	Flange ANSI 1/2" 300# RF/SF	220	8.66	A2
	Flange ANSI 1/2" 600# RF/SF	220	8.66	A3
	Flange ANSI 1/2" 1500# RF/SF	300	11.81	A6
	Flange ANSI 1/2" 1500# RTJ	300	11.81	R1
Optional	Flange DIN DN15/PN160	220	8.66	D3
	Flange JIS RF 10k 15A (1/2")	220	8.66	J1
	Flange JIS RF 20k 15A (1/2")	220	8.66	J2

Type welded, single path measuring loops without seals and flange connection
H2 = 205 mm (8.07 in)

A1 = 130 mm (5.12 in)
A2 = 145 mm (5.71 in)
H1 = 173 mm (6.79 in)

B1 = 25 mm (0.98 in)
B2 = 40 mm (1.57 in)

Terminal box (without cable gland) 125 x 80 x 58 mm (4.92 x 3.15 x 2.28 in)
W = 0 mm for Temperature Range T1 and TA
W = 100 mm (3.94 in) for Temperature Range T4

No terminal box, 2 m free PTFE cable ends for Temperature Range T2 and T3

Weight in standard manifold construction with female threads: approx. 2.5 kg (5.5 lb)

Weight in standard sealless construction and 150# flanges: approx. 3.5 kg (7.7 lb)

Shipping in carton box approx. 60 x 41 x 32 cm (24 x 16 x 13 in), gross weight with sealless construction, 150# standard flanges and RHE 08 transmitter approx. 10 kg (22 lb)

Finish type of our ANSI flanges corresponds to SF (AARH 125 up to 250 µm, Ra 3.2 up to 6.3 µm)

For customization with regard to face to face length and special fittings, please consult your local agent

Please note that larger diameter process connections are always possible

Reading Office

Cutbush Park, Danehill, Lower Earley,
Reading, Berkshire. RG6 4UT. UK.
Tel: +44 (0)118 9311188
Email: info@able.co.uk

Aberdeen Office

Unit 6 Airside Business Park, Kirkhill Industrial Estate,
Dyce, Aberdeen. AB21 0GT. UK.
Tel: +44 (0)1224 725999
Email: ab@able.co.uk

Internet: www.able.co.uk
e-procurement: www.247able.com
Registered in England No: 01851002
VAT No: GB 417 2481 61



Pressure Rating RHM 015

The maximum pressure (pmax) of a sensor is determined by its weakest part. The weakest part can be the measuring loops (pmax indicated below) or the construction type (pmax indicated in the Basic Order Code section, last page) or the selected flanges / fittings (for pmax please see respective standard).

pmax of P1 measuring loops, standard M0 standard material - 1.4539 (904 L) OD x WT 1.5 x 0.2 mm (0.06 x 0.008 in)

bar	°C	psi	°F
362	50	5250	122
300	120	4351	248
250	210	3626	410
200	350	2901	662

pmax of P1 measuring loops M3 optional material - 2.4602 (Alloy C22) OD x WT 1.5 x 0.25 mm (0.06 x 0.01 in)

bar	°C	psi	°F
450	50	6527	122
400	120	5802	248
350	210	5076	410
300	350	4351	662

pmax of P2 measuring loops M0 standard material - 1.4539 (904 L) OD x WT 1.5 x 0.25 mm (0.06 x 0.01 in)

bar	°C	psi	°F
467	50	6773	122
400	120	5802	248
300	210	4351	410
250	350	3626	662

pmax of P1 measuring loops M1 optional material - 1.4571 (316Ti) OD x WT 1.5 x 0.2 mm (0.06 x 0.008 in)

bar	°C	psi	°F
332	50	4815	122

pmax of P3 measuring loops M0 standard material - 1.4539 (904 L) OD x WT 1.5 x 0.5 mm (0.06 x 0.02 in)

bar	°C	psi	°F
752	50	10907	122
700	120	10153	248
600	210	8702	410
500	350	7252	662

Reading Office

Cutbush Park, Danehill, Lower Earley,
Reading, Berkshire. RG6 4UT. UK.
Tel: +44 (0)118 9311188
Email: info@able.co.uk

Aberdeen Office

Unit 6 Airside Business Park, Kirkhill Industrial Estate,
Dyce, Aberdeen. AB21 0GT. UK.
Tel: +44 (0)1224 725999
Email: ab@able.co.uk

Internet: www.able.co.uk
e-procurement: www.247able.com
Registered in England No: 01851002
VAT No: GB 417 2481 61



Performance RHM 015

Max Flow Rate Q_{max} and Q_{nom} (*) = 0.6 kg/min (1.32 lb/min)

Standard Models		
Flow Rate		Uncertainty
kg/min	lb/min	in % of reading
0.600	1.323	0.20
0.300	0.661	0.20
0.100	0.220	0.20
0.030	0.066	0.20
0.008	0.018	0.50

Goldline Models (**)- selected sensors		
Flow Rate		Uncertainty
kg/min	lb/min	in % of reading
0.600	1.323	0.10
0.300	0.661	0.10
0.100	0.220	0.10
0.060	0.132	0.10
0.030	0.066	0.12

Low Flow Models (**)- selected sensors		
Flow Rate		Uncertainty
kg/min	lb/min	in % of reading
0.160	0.353	0.20
0.100	0.220	0.20
0.050	0.110	0.20
0.008	0.018	0.20
0.003	0.007	0.60

Repeatability

Better $\pm 0.1\%$ of rate,
Goldline 0.05%

Temperature

Better $\pm 1^\circ\text{C}$

(*) Nominal flow Q_{nom} refers to roughly 8 - 10 m/s (26-33 ft/s) velocity in measuring loops for best performance.

(**) Selected sensors are only available in combination with temperature option T1, standard material and pressure range.

- Serial/single path versions offer the same accuracy at half the flow (Q_{max} serial version = 0.3 kg/min).
- No relevant pressure effect due to torsional oscillation and semi-circle (non-deforming) measurement section.

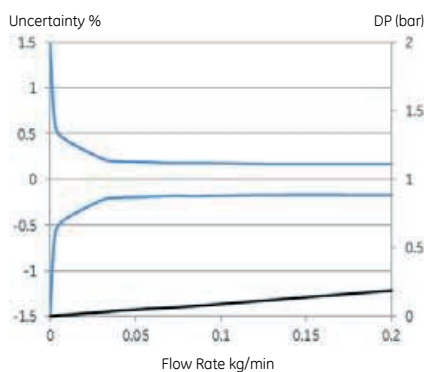
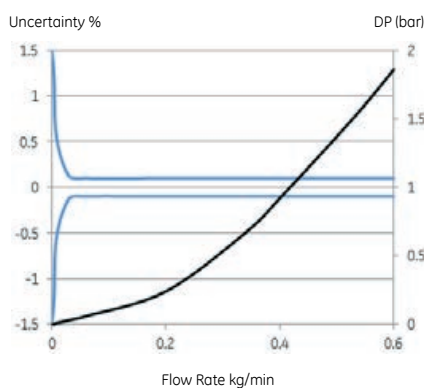
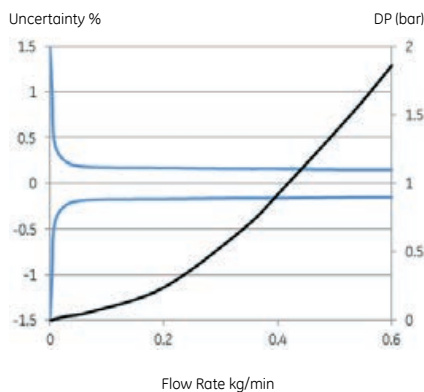

- Uncertainty of reading (incl. zero drift) indications refer to reference conditions H_2O , 18-24°C (66 - 76°F), 1 - 3 bar (15 - 45 psi) and installation according to field manual.
- Pressure drop indications refer to H_2O , with parallel measuring loops type P1 and standard manifold block connections.
- For calibration to customer range and / or with improved uncertainty, please consult factory.

Reading Office

Cutbush Park, Danehill, Lower Earley,
Reading, Berkshire. RG6 4UT. UK.
Tel: +44 (0)118 9311188
Email: info@able.co.uk

Aberdeen Office

Unit 6 Airside Business Park, Kirkhill Industrial Estate,
Dyce, Aberdeen. AB21 0GT. UK.
Tel: +44 (0)1224 725999
Email: ab@able.co.uk

Internet: www.able.co.uk
e-procurement: www.247able.com
Registered in England No: 01851002
VAT No: GB 417 2481 61



General Specifications RHM 015

Temperature Range

- NT Models from -20 to +120°C (-4 to +248°F)
- ET Models from -45 to +120°C (-49 to +248°F)
- ET2 Models from -45 to +210°C (-49 to +410°F)
- ET1 Models from -196 to +50°C (-320 to +122°F)
- HT Models from 0 to 350°C (32 to +662°F)
(Heating for housing optional, please consult your local agent)

Electrical Connection

- Junction box Aluminium coated (standard). Junction box in SS 316Ti optional
- Cable entry M25 x 1.5. Optional cable entries M20 x 1.5, 1/2" NPT or 3/4" NPT
- Max cable length between RHM and RHE is 100m (330 ft). 200m (660 ft) only with factory approval

Material of Wetted Parts

- 1.4539 / SS 904 L / UNS N08904 (standard measuring loops material)
- 1.4571 / SS 316 Ti / UNS S31635 (standard connection part material, optional measuring loops material)
- 2.4602 / Alloy C22 / UNS N06022
- Tantalum
- Others on request

Sensor Enclosure/Housing

- Stainless Steel 1.4301 / SS 304, optional in 1.4571 / SS 316Ti. Others on request
- Protection Class IP 65. Optional IP 66 / NEMA 4x

Approvals

- ATEX (CESI 02 ATEX 053 X) Ex II 1 G, EEx ia IIC T6-T1
- CSA Class I, Div 1 and 2, Groups A, B, C and D
- PED according to directive 97/23/EC Art.3 (3) Sound Engineering Practice (SEP)
- Others on request

Reading Office

Cutbush Park, Danehill, Lower Earley,
Reading, Berkshire. RG6 4UT. UK.
Tel: +44 (0)118 9311188
Email: info@able.co.uk

Aberdeen Office

Unit 6 Airside Business Park, Kirkhill Industrial Estate,
Dyce, Aberdeen. AB21 0GT. UK.
Tel: +44 (0)1224 725999
Email: ab@able.co.uk

Internet: www.able.co.uk
e-procurement: www.247able.com
Registered in England No: 01851002
VAT No: GB 417 2481 61



Basic Order Code RHM 015

Sensor Size

Temperature Range

- T1 NT from -20°C to +120°C (standard)
- TA ET from -45°C to +120°C
- T2 ET2 Extended Temperature Range from -45°C to +210°C
- T3 ET1 Extended Temperature Range from -196°C to +50°C
- T4 HT High Temperature Range from 0°C to +350°C

Pressure Range of Measuring Loops @ 120°C

- P1 pmax = 300 bar, M0 Material (standard)
- P2 pmax = 400 bar, M0 Material
- P3 pmax = 700 bar, M0 Material

Construction Type (pmax indications @ 120°C)

- PM0 Parallel Measuring Loops with removable Manifold and PTFE Seals, pmax = 400 bar with thread connection, 214 bar with flange connection
- SM0 Serial Measuring Loops with removable Manifold and PTFE Seals, pmax = 400 bar with thread connection, 214 bar with flange connection
- PF0 Parallel Measuring Loops Seal Less Version
- SF0 Serial Measuring Loops Seal Less Version, pmax = 233 bar
- PFT Parallel Measuring Loops Seal Less Version for Thread Connection, pmax = 530 bar
- SFT Serial Measuring Loops Seal Less Version for Thread Connection, pmax = 233 bar
- PH0 Parallel Measuring Loops with removable High Pressure Manifold and PTFE Seals, pmax = 700 bar with N1, P2; pmax = 540 bar with G1
- SH0 Serial Measuring Loops with removable High Pressure Manifold and PTFE Seals, pmax = 700 bar with N1, P2; pmax = 540 bar with G1

Material of Wetted Parts

- M0 Measuring Loops 1.4539 (904L), Manifold/Connection 1.4571 (316Ti) (standard)
- M1 Measuring Loops and Manifold/Connection 1.4571 (316Ti)
- M3 Measuring Loops and Connection Part 2.4602 (Alloy C22), Seal Less Construction Types only
- M4 Measuring Loops and Connection Part Tantalum; PF0, SF0 Construction Type only

Process Connection

- D1 Flange DIN DN15/PN40 Form C
- D2 Flange DIN DN15/PN100 Form E
- A1 Flange ANSI ½" 150# RF/SF
- A2 Flange ANSI ½" 300# RF/SF
- A3 Flange ANSI ½" 600# RF/SF
- R1 Flange ANSI ½" 1500# RTJ
- R2 Flange ANSI ½" 2500# RTJ
- A6 Flange ANSI ½" 1500# RF
- A8 Flange ANSI ½" 2500 RF/SF
- G1 Female Thread G ¼"
- N1 Female Thread ¼" NPT
- W1 Swagelok ¼" tube inlet (SS-400-1-4W) - valid for SS only
- S1 Sanitary ½" Triclamp, DIN 32676, pmax = 40 bar @ 120°C
- S2 Sanitary NW10, DIN 11851, pmax = 40 bar @ 120°C
- P2 Autoclave 3/8" MP (9/16-18 UNF female thread)
- Others on request

RHM 015 - - - -



www.ge-mcs.com

920-497A

© 2013 General Electric Company. All Rights Reserved. Specifications are subject to change without notice. GE is a registered trademark of General Electric Company. Other company or product names mentioned in this document may be trademarks or registered trademarks of their respective companies, which are not affiliated with GE.

Reading Office

Cutbush Park, Danehill, Lower Earley,
Reading, Berkshire. RG6 4UT. UK.
Tel: +44 (0)118 9311188
Email: info@able.co.uk

Aberdeen Office

Unit 6 Airside Business Park, Kirkhill Industrial Estate,
Dyce, Aberdeen. AB21 0GT. UK.
Tel: +44 (0)1224 725999
Email: ab@able.co.uk

Internet: www.able.co.uk
e-procurement: www.247able.com
Registered in England No: 01851002
VAT No: GB 417 2481 61

