

PROCESS TECHNOLOGY

INDUSTRIAL SOLIDSIZER™ Particle Analysis System



FEATURES

- Particle distribution by major, minor diameter, area, perimeter available with Canty Vector System
- Real time, on-line particle size analysis
- Adjustable lens magnification (sub micron through boulders – no upper size limit). Consult factory
- Fiber optic lighting backlighting for true shape illumination
- Shape Analysis
- External video connectors for signal processing by Canty Vector System (optional)
- Optional light filters available for wavelength sensitive materials

ONLINE PARTICLE SIZING

The Canty Industrial SolidSizer™ is an on-line particle sizing tool for lab environments to determine particle size, shape and distribution, thereby eliminating the need for sieve analysis.

THE CANTY ADVANTAGE

The JM Canty Industrial SolidSizer™ is a vision-based sensor used with the Vector System for dry particle size measurement in a production environment as an on-line production tool. The SolidSizer™ includes a B & W camera with a shutter speed control and a variable magnification lens, a light source with a flexible fiber optic light guide to generate a uniform light field to display silhouette images of opaque particles, and a vibratory feeder to present sample material to the camera / lights in free fall. The weatherproof camera is equipped with a spray ring that can be charged intermittently to control dust buildup on the outside of the camera view port. The camera video is provided to the Vector System for analysis that extracts particle size information. This sheet identifies the features of the SolidSizer™ and provides ordering information. Typical installations also include the Vector System.

APPLICATIONS

- Pharmaceutical powders
- Polymer pellets and beads
- Agricultural products
- Aggregates
- Crushed rock
- Glass bead applications
- Screen break detection
- Agglomeration control
- Spray dryers and fluid bed applications
- Replaces existing lab screen / sieve systems
- End product Q.C. and lot certification
- Many, Many More

SPECIFICATIONS

- Power: 120V AC / 60 Hz (230V AC / 50 Hz)
- Shutter Speed: variable up to 1/100,000 sec
- Instrument Air: 20 to 30 PSI when required

BENEFITS

- Reduces Lab Screening Labor by 99%
- Output Matches Sieve/Screen Data - Direct Replacement
- Three Month Pay Back

Ordering Information

HOW TO ORDER: Select the appropriate symbols and build a model number as shown:

EXAMPLE:

S C - 1 2

STYLE SELECTION

C - Industrial

VIDEO SYSTEM FORMAT

G - Gigabit Ethernet, B&W, 1600 x 1200

H - Gigabit Ethernet, Color, 1600 x 1200

ENVIRONMENTAL RATING

2 - Weatherproof

3 - Explosionproof

SYSTEM ILLUMINATION

K - Backlighting

L - Back / Front (Ringlight), Black Speck Only

ACCESSORIES

1 - No Accessories

2 - Black Speck Only

3 - Particle Size and Black Speck

TRAY MATERIAL

2 - Stainless Steel

INPUT POWER

1 - 120 V AC 60Hz

2 - 230 V AC 50Hz

LENS

1 - Macro Zoom

PS range 10-6000 Microns

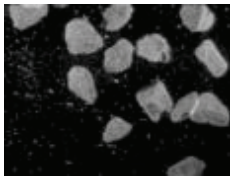

Live Image

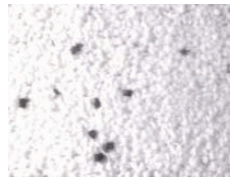

Black Speck Detection

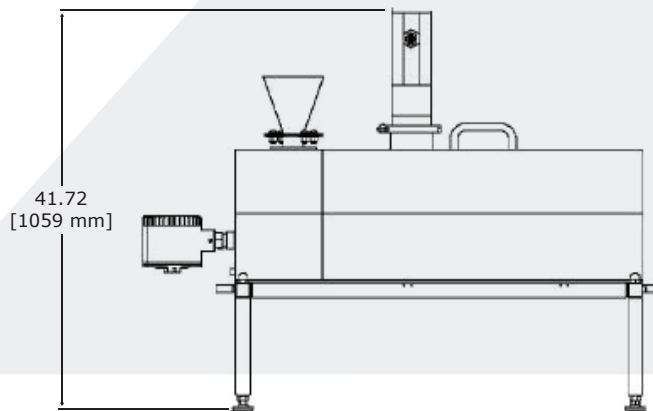
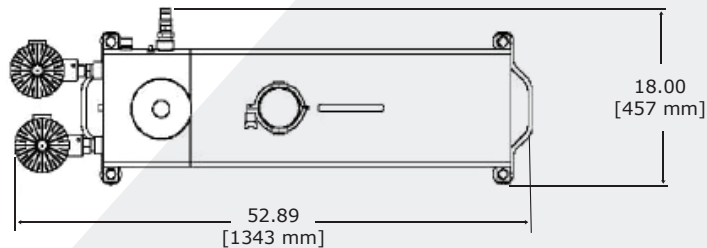

* Fines separator is used to separate small particles (under 80 micron) for optimal particle orientation. Consult factory if required for your application.

Reading Office

Cutbush Park, Danehill, Lower Earley,
Reading, Berkshire. RG6 4UT. UK.
Tel: +44 (0)118 9311188
Email: info@able.co.uk

Aberdeen Office

Unit 6 Airside Business Park, Kirkhill Industrial Estate,
Dyce, Aberdeen. AB21 0GT. UK.
Tel: +44 (0)1224 725999
Email: ab@able.co.uk

Internet: www.able.co.uk
e-procurement: www.247able.com
Registered in England No: 01851002
VAT No: GB 417 2481 61

