

PROCESS TECHNOLOGY

ASEPTIC NA-CONNECT® FUSEVIEW™ SIGHT GLASS



THE CANTY ADVANTAGE

JM Canty Fuseview™ sight glasses have been engineered to meet all your process and safety needs. NA-Connect® Fuseviews™ are a fused sight glass providing one-piece construction with no additional gaskets or torquing required. All standard NA-Connect® Fuseviews™ were designed and tested to ensure the safest product available. Canty can provide certification of material and testing if required, typical of ASME code

FUSEVIEW™ VS TEMPERED GLASS

Canty Fuseviews™ are fused from superior nickel alloys. Using Boro Plus™ glass fusing technology, the pre-stressed metal ring prevents formation of the glass stresses usually associated with tempered borosilicate sight glasses.

Used in conjunction with any standard NA-Connect® mount pad, our sight glass greatly increases safety over the traditional tempered glass or plastic windows used in aseptic and sanitary applications.

FEATURES

- Eliminates air pockets and trapped material
- Designed for full torquing. No over-torquing to gaskets or window ring can occur
- Locking ring is split for ease of mounting and increased safety
- Unit stays in place during CIP and SIP
- Drainable during external wash down
- NA-Connect® Fitting rated to 101 PSI [7 bar] @ 392°F [200°C]. Fuseview™ rated to 150 PSI [10 bar] @ 400°F [204°C]. Higher ratings available on request.
- Suitable for standard Tri-Clamp® connections
- Custom sizes available upon request
- Fuseview™ provides maximum available view into the process
- No loss of glass temper over time
- Scratches do not affect safety or life
- Unlike tempered glass, a Fuseview™ will not experience catastrophic failure if the surface is damaged
- Superior metal properties for unmatched performance
- Extremely high strength due to radial compression on the hermetically sealed glass
- Very high impact strength and thermal shock resistance due to pre-stressing
- Operates under positive or negative pressure
- Certification on material and pressure rating is

OPTIONS

- Lighting - Flex bundle light available to eliminate the need for a second nozzle. View and illuminate through one port!
- Integral one piece design eliminates the need for a separate retainer. This creates a smooth crevice free exterior surface to match the interior side. See the separate data sheet for details.

All registered trademarks are the property of their respective owners.

Reading Office

Cutbush Park, Danehill, Lower Earley,
Reading, Berkshire. RG6 4UT. UK.
Tel: +44 (0)118 9311188
Email: info@able.co.uk

Aberdeen Office

Unit 6 Airside Business Park, Kirkhill Industrial Estate,
Dyce, Aberdeen. AB21 0GT. UK.
Tel: +44 (0)1224 725999
Email: ab@able.co.uk

Internet: www.able.co.uk
e-procurement: www.247able.com
Registered in England No: 01851002
VAT No: GB 417 2481 61



NA-CONNECT® FUSEVIEW™ SPECIFICATIONS

BILL OF MATERIALS

ITEM	DESCRIPTION
1	MOUNT PAD (CUSTOMER SUPPLIES)
2	GASKET (CUSTOMER SUPPLIES)
3	CANTY NA-CONNECT® FUSEVIEW™
4	RETAINER (CUSTOMER SUPPLIES)
5	STUDS (CUSTOMER SUPPLIES)
6	NUTS (CUSTOMER SUPPLIES)

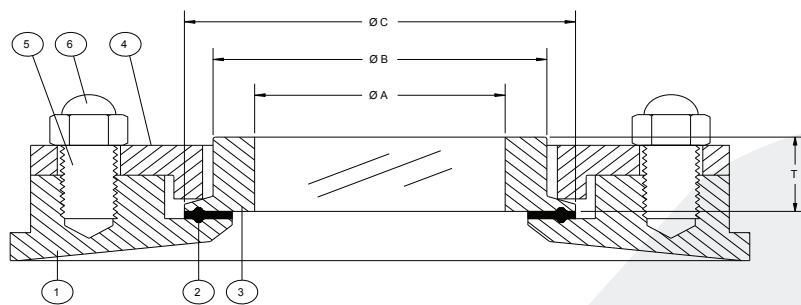

NA CONNECT® SIZE	VIEW ØA	ØB	ØC	T
1.5" / 40mm	.94" [24mm]	1.50" [38mm]	1.98" [50mm]	.68" [17mm]
2" / 50mm	1.13" [29mm]	2.00" [51mm]	2.51" [64mm]	.68" [17mm]
2.5"	1.50" [38mm]	2.50" [64mm]	3.05" [78mm]	.68" [17mm]
3" / 65mm	2.00" [51mm]	3.00" [76mm]	3.58" [91mm]	.68" [17mm]
80 mm	2.50" [63.5mm]	3.50" [88.9mm]	4.17" [106mm]	.68" [17mm]
4" / 100mm	3.00" [76mm]	4.00" [102mm]	4.69" [119mm]	.68" [17mm]

Ordering Information

HOW TO ORDER: Select the appropriate symbols and build a part number as shown:

EXAMPLE:

SDA 1 0A0

SIZE:

- A = 1.5" / 40mm
- B = 2" / 50 mm
- C = 2.5"
- D = 3" / 65mm
- 4 = 80mm
- E = 4" / 100mm

- FINISH: (wetted)(non-wetted=32 µin [.81 µm] Ra)
- 0 = 20 µin [.51 µm] Ra (standard)(BPE-SF1)
- C = 15 µin [.38 µm] Ra
- L = 20 µin [.51 µm] Ra Electropolished (BPE-SF5)
- M = 15 µin [.38 µm] Ra Electropolished (BPE-SF4)

MATERIAL (wetted):

- B = 316L Stainless Steel*
- C = Alloy C (4" / 100mm only)
- D = Hastelloy® C276 or equal
- E = Hastelloy® C-22® or equal

*Canty reserves the right to upgrade to Hastelloy® C-family of alloys or equal at their own cost.