



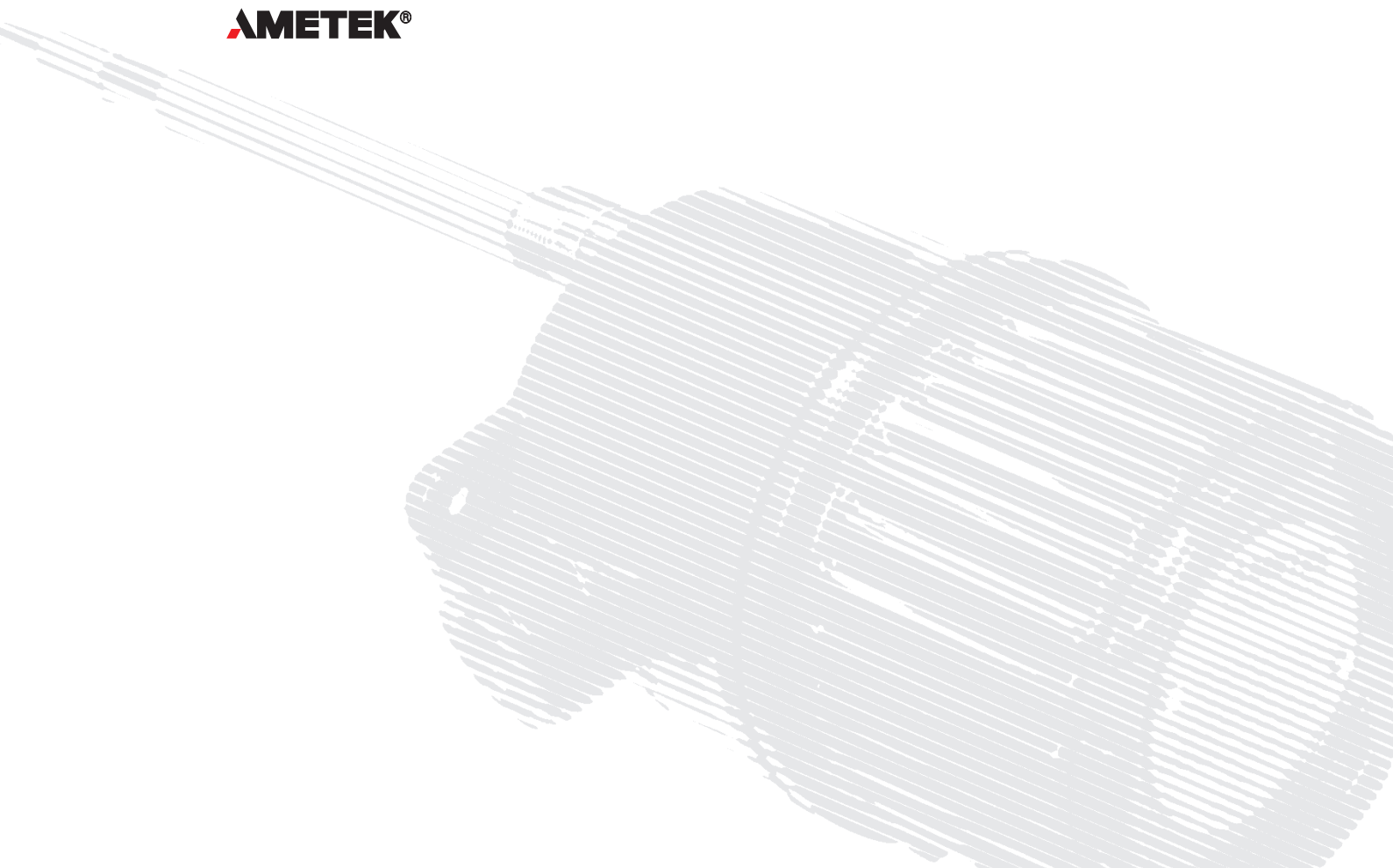
Installation & Maintenance Instructions

# Z-tron IV™ Point Level Control

**DREXELBROOK®**

A Leader In Level Measurement Solutions

**AMETEK®**



**Reading Office**

Cutbush Park, Danehill, Lower Earley,  
Reading, Berkshire. RG6 4UT. UK.  
Tel: +44 (0)118 9311188  
Email: info@able.co.uk

**Aberdeen Office**

Unit 6 Airside Business Park, Kirkhill Industrial Estate,  
Dyce, Aberdeen. AB21 0GT. UK.  
Tel: +44 (0)1224 725999  
Email: ab@able.co.uk

Internet: www.able.co.uk  
e-procurement: www.247able.com  
Registered in England No: 01851002  
VAT No: GB 417 2481 61





Leader in  
Level Measurement

For Assistance Call 1-800-527-6297  
Outside North America + 215-674-1234

# Installation and Operating Instructions

Z-tron IV™  
Point Level Control

U.S. and Canada: 1-800-553-9092  
24-Hour Service: 1-800-527-6297  
International: +1 215-674-1234  
Fax: +1 215-674-2731  
E-mail: [drexelbrook.service@ametek.com](mailto:drexelbrook.service@ametek.com)  
Website: [www.drexelbrook.com](http://www.drexelbrook.com)

AMETEK Drexelbrook makes no warranty of any kind with regard to the material contained in this manual, including, but not limited to, implied warranties or fitness for a particular purpose. Drexelbrook shall not be liable for errors contained herein or for incidental or consequential damages in connection with the performance or use of material.

© Copyright AMETEK Drexelbrook

EDO# 6-13-116  
Z-tronIV-LM  
Issue#2

## Z-tron IV™ Point Level Control



**AMETEK®**  
**DREXELBROOK**  
*An ISO 9001 Certified Company*

205 Keith Valley Road, Horsham, PA 19044  
U.S. and Canada: 1-800-553-9092  
24-Hour Service: 1-800-527-6297  
International: +1 215-674-1234  
Fax: +1 215-674-2731  
E-mail: [drexelbrook.info@ametek.com](mailto:drexelbrook.info@ametek.com)  
Website: [www.drexelbrook.com](http://www.drexelbrook.com)

## **Table of Contents**

# Contents

<b>Section 1: Introduction</b> .....	<b>1</b>
1.1 System Description .....	1
1.2 Technology .....	1
1.3 Spare Parts .....	1
1.4 Model Number .....	2
<b>Section 2: Installation</b> .....	<b>3</b>
2.1 Unpacking .....	3
2.2 Mounting the Level Control .....	3
2.3 Integral Mounting Dimensions .....	5
2.4 Remote Mounting Dimensions .....	6
2.5 Power Wiring .....	7
2.6 Relay Wiring .....	10
2.7 Wiring the Sensing Element (Remote) .....	11
2.8 Wiring the Sensing Element (Integral) .....	12
<b>Section 3: Operation</b> .....	<b>13</b>
3.1 Setpoint Control .....	13
3.2 Time Delay Control .....	14
3.3 Time Delay Action .....	14
3.4 Failsafe .....	15
3.5 Start-up .....	15
<b>Section 4: Calibration</b> .....	<b>17</b>
4.1 Calibration in Conducting Material .....	17
4.2 Calibration in Insulating Material [Horizontal Mount] .....	18
4.3 Calibration in Insulating Material [Vertical Mount] .....	19
<b>Section 5: Troubleshooting</b> .....	<b>21</b>
5.1 Introduction .....	21
5.2 Testing Electronic Unit .....	21
5.3 Testing Sensing Element .....	22
5.4 Testing Relay Circuits .....	24
5.5 Testing Remote Cable .....	25
5.6 Possible Problems and Causes .....	26
5.7 Factory Assistance .....	27
5.8 Field Service .....	27
5.9 Customer Training .....	27
5.10 Equipment Return .....	28
<b>Section 6: Specifications</b> .....	<b>29</b>
<b>Appendix A: Shortening or Lengthening the Sensing Element</b> .....	<b>1</b>

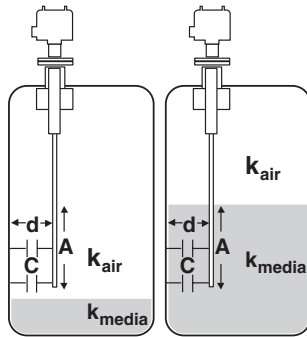
## **Section 1**

## Section 1: Introduction

These instructions are for the AMETEK Drexelbrook Z-tron IV™ Series Point Level Control.

The label on top of the electronic unit identifies the model number of the Z-tron IV level control.

### 1.1 System Description



$$C = \frac{k A}{d} \quad C \uparrow = \frac{k \uparrow A}{d}$$

*Figure 1-1*  
**Capacitance Probe**  
**(Insulating Media)**

Cote-Shield™ action is designed into all Z-tron IV level controls and enables the instrument to ignore the effect of buildup or material coating on the sensing element.

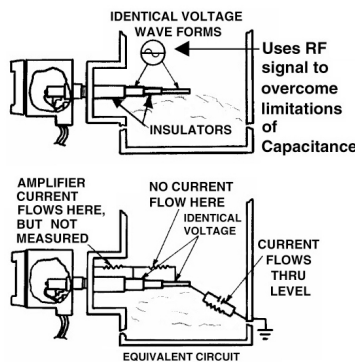
The electronic unit:

- Provides double-pole double-throw dry relay contact closure when material reaches a specific point on the sensor. The relay contacts may be used to operate alarms, solenoid valves, or other low power devices.
- Provides a 0-60 second time delay for agitated vessels.

The 700-series sensing element:

- Is mounted on the tank or in the process.
- Provides a change in radio frequency (RF) admittance indicating presence or absence of material.

### 1.2 Technology



*Figure 1-2*  
**RF Admittance Probe**  
**with Cote-Shield**

In a simple capacitance probe type sensing element, when the level rises and material covers the probe, the capacitance within the circuit between the probe and the medium (conductive applications) or the probe and the vessel wall (insulating applications) increases. This is due to the dielectric constant (k) of the material, which causes a bridge misbalance. The signal is demodulated (rectified), amplified and the output is increased. There are drawbacks, however, especially when there is coating of the probe.

An RF Admittance level transmitter is the next generation. Although similar to the capacitance concept, The Z-tron employs a radio frequency signal and adds the Cote-Shield™ circuitry within the Electronics Unit.

This patented Cote-Shield™ circuitry is designed into Z-tron series and enables the instrument to ignore the effect of buildup or material coating on the sensing element. The sensing element is mounted in the vessel and provides a change in RF admittance indicating presence or absence of material.

The Cote-Shield™ element of the sensor prevents the transmission of RF current through the coating on the sensing element. The only path to ground available for the RF current is through the material being measured.

The result is an accurate measurement regardless of the amount of coating on the probe, making it by far the most versatile technology, good for very wide range conditions from cryogenics to high temperature, from vacuum to 10,000 psi pressure, and works with all types of materials.

### 1.3 Spare Parts

120/ 240 VAC Electric Unit  
24 DC Electronic Unit

Part # - 385-0075-042  
Part # - 385-0075-041



## 1.4 Model Number

**Technology**  
**Z4** Z-tron IV RF Admittance Level Measurement System

**Input Power**  
**1** 24 VDC  
**2** 115 VAC, Field Selectable  
**3** 230 VAC, Field Selectable

**Electronics**

<b>0</b> Integral (No Cable)	<b>6</b> Remote w/ 25 Ft Gp Cable	<b>C</b> Remote w/ 5 Ft Hi Temp Cable	<b>I</b> Remote w/ 75 Ft Hi Temp Comp Cable
<b>1</b> Remote w/ Out Cable	<b>7</b> Remote w/ 35 Ft Gp Cable	<b>D</b> Remote w/ 10 Ft Hi Temp Cable	<b>J</b> Remote w/ 100 Ft Hi Temp Comp Cable
<b>2</b> Remote w/ 5 Ft Gp Cable	<b>8</b> Remote w/ 50 Ft Gp Cable	<b>E</b> Remote w/ 15 Ft Hi Temp Comp Cable	<b>K</b> Remote w/ 150 Ft Hi Temp Comp Cable
<b>3</b> Remote w/ 10 Ft Gp Cable	<b>9</b> Remote w/ 75 Ft Gp Cable	<b>F</b> Remote w/ 20 Ft Hi Temp Comp Cable	
<b>4</b> Remote w/ 15 Ft Gp Cable	<b>A</b> Remote w/ 100 Ft Gp Cable	<b>G</b> Remote w/ 25 Ft Hi Temp Comp Cable	
<b>5</b> Remote w/ 20 Ft Gp Cable	<b>B</b> Remote w/ 150 Ft Gp Cable	<b>H</b> Remote w/ 50 Ft Hi Temp Comp Cable	

**OEM Code**

**Series**  
**1** Standard

**Sensing Element** \* temperatures > 300 °F require a 6" cooling extension

Model #	Press. &Temp.	Wetted Parts	
101	700-1202-001	200 psi @ 450°F	316 SS and PEEK
103	700-1202-014	200 psi @ 450°F	316 SS and PEEK
106	700-1202-041	1000 psi @ 250°F / 300 psi @ 450°F	316 SS and PEEK
301	700-0001-022	1000 psi @ 100°F / 500 psi @ 300 °F	316 SS and TFE
325	700-1202-031	200 psi @ 450°F	316 SS and PEEK, FDA approved
327	700-0202-002	50 psi @ 300 °F / 20 psi @ 450 °F*	316 SS and TFE
701	700-0001-018	50 psi @ 300 °F	PFA
753	700-0206-101	200 psi @ 250°F	316 SS and TFE
754	700-0029-001	2 psi @ 500 °F	316 SS and TFE
755	700-0029-002	2 psi @ 500 °F	316 SS and TFE
756	700-0029-003	2 psi @ 500 °F	316 SS and TFE
757	700-0029-004	2 psi @ 500 °F	316 SS and TFE
758	700-0029-005	2 psi @ 500 °F	316 SS and TFE
760	700-0029-021	2 psi @ 500 °F	316 SS and TFE
761	700-0029-022	2 psi @ 500 °F	316 SS and TFE
762	700-0029-023	2 psi @ 500 °F	316 SS and TFE
763	700-0029-024	2 psi @ 500 °F	316 SS and TFE
764	700-0029-025	2 psi @ 500 °F	316 SS and TFE
766	700-0029-102	2 psi @ 1500 °F	316 SS and Alumina
767	700-0029-103	2 psi @ 1500 °F	316 SS and Alumina
768	700-0029-104	2 psi @ 1500 °F	316 SS and Alumina
769	700-0029-105	2 psi @ 1500 °F	316 SS and Alumina
770	700-0029-106	2 psi @ 1500 °F	316 SS and Alumina

**Process gland wetted part (X)**  
**B** 316/316L SS  
**P** PFA (700-0001-018)  
**X\*** Upon request

**Process connection (XX)**

<b>A0</b>	3/4" NPT	
<b>B0</b>	1" NPT	
<b>BA</b>	1" 150# RF	Carbon Steel
<b>BB</b>	1" 150# RF	316/316L Stainless Steel
<b>CA</b>	1" 300# RF	Carbon Steel
<b>CB</b>	1" 300# RF	316/316L Stainless Steel
<b>FA</b>	2" 150# RF	Carbon Steel
<b>FB</b>	2" 150# RF	316/316L Stainless Steel
<b>GA</b>	2" 300# RF	Carbon Steel
<b>GB</b>	2" 300# RF	316/316L Stainless Steel
<b>IA</b>	3" 150# RF	Carbon Steel
<b>IB</b>	3" 150# RF	316/316L Stainless Steel
<b>JA</b>	3" 300# RF	Carbon Steel
<b>JB</b>	3" 300# RF	316/316L Stainless Steel
<b>KA</b>	4" 150# RF	Carbon Steel
<b>KB</b>	4" 150# RF	316/316L Stainless Steel
<b>LA</b>	4" 300# RF	Carbon Steel
<b>LB</b>	4" 300# RF	316/316L Stainless Steel

**XX\*** Many more options available upon request (ASME/ANSI, DIN)

**Insertion Length in mm**  
 XXXXXX Length of the probe in millimeters from process connection to the bottom of the probe

**Cote-Shield™ Length in mm**  
 XXXXXX Length of the Cote-Shield in millimeters for 3-terminal probes. Not applicable for 2-terminal probes

**Inactive Length in mm**  
 XXXXXX Length of the inactive part of the probe that is not measured.  
 This option is primarily used in Interface measurement and Desalters

**Inactive Material**  
**B** 316/316L SS  
**N** Not Applicable  
**X\*** Many more options are available upon request

## Section 2: Installation

### 2.1 Unpacking

Carefully remove the contents of the shipping carton and check each item against the packing list before destroying any packing materials. If there is any shortage or damage, report it to the factory at 1-800-527-6297 (US and Canada) or + 215-674-1234 (International).

### 2.2 Mounting the Level Control

The Z-tron IV Level Control is available with the electronic unit and sensing element as a single integral assembly. Extended sensing element lengths and special mountings can be provided to fit specific applications.

- The Z-tron IV Level Control is designed for industrial applications, but it should be mounted in a location as free as possible from vibration, corrosive atmospheres, or any possibility of mechanical damage.
- For convenience when adjusting, place the electronic unit in a reasonably accessible location. Ambient temperature should be between -40°F and 145°F (-40°C to 63°C).
- It may be mounted either vertically or horizontally. See Figures 2-1 and 2-2.

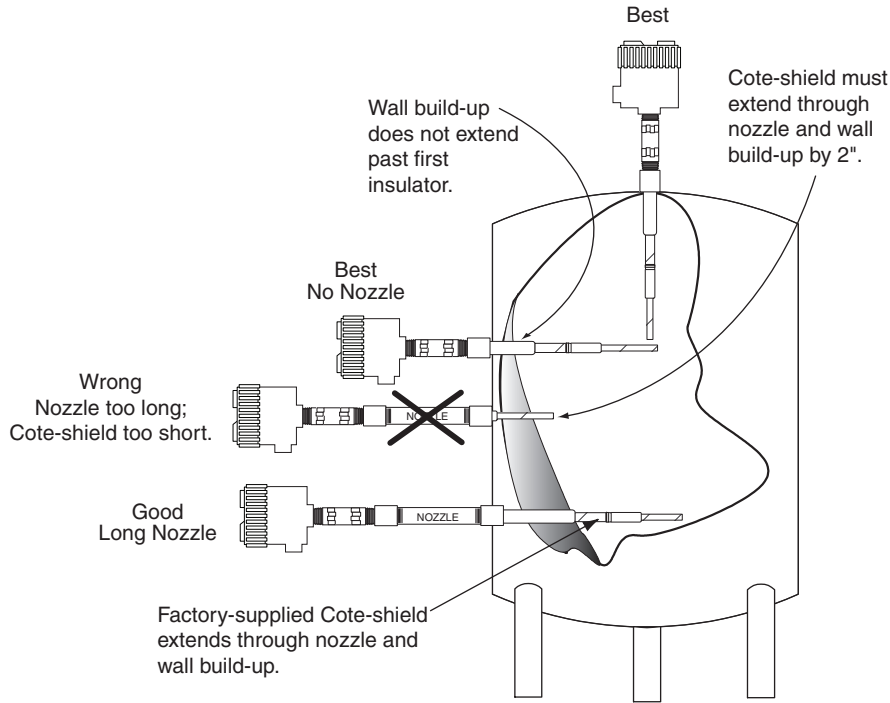


**Note:** The 700-0001-018 is designed for vertical mounting only

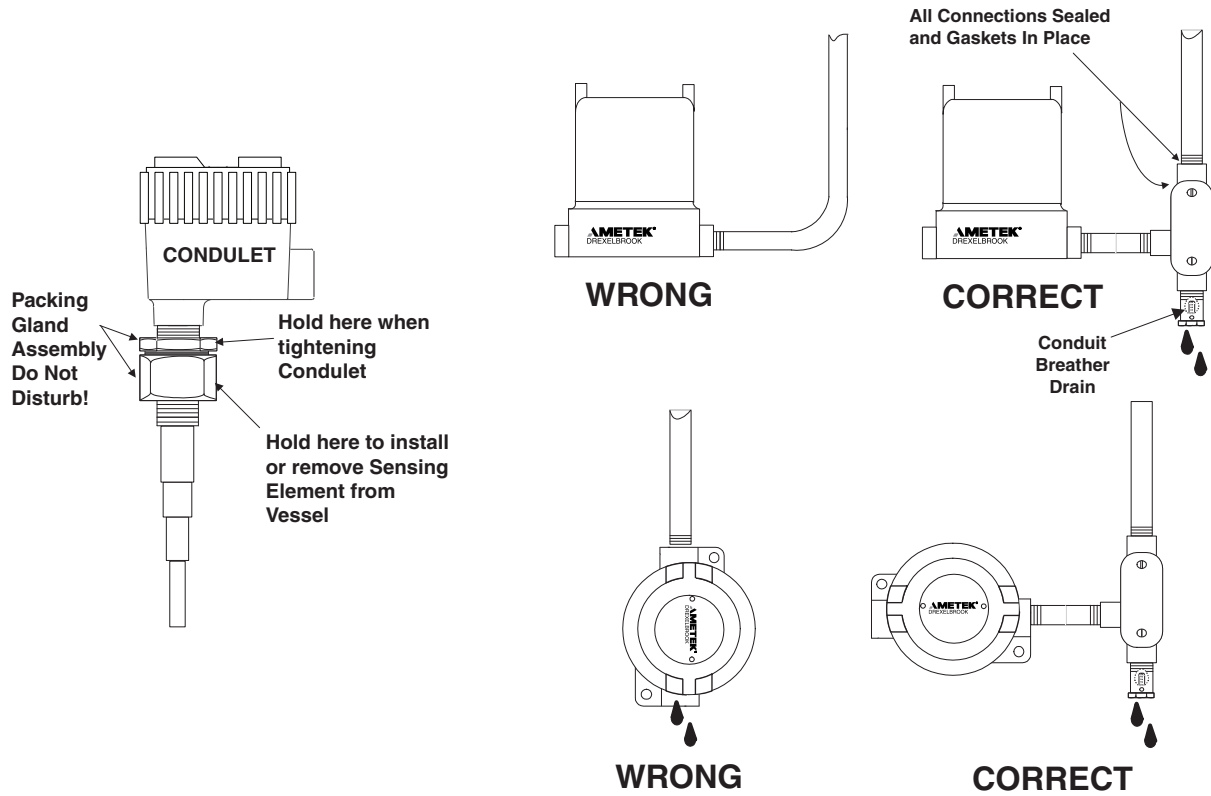
- Avoid mounting closer than 1 inch to any tank structure. Material bridging from structure to sensing element can cause false alarms. Close proximity to tank structure also increases the sensing element's standing capacitance.
- When installing flange-mounted sensing elements, keep mating surfaces and bolts free of paint and corrosion to ensure proper electrical contact with vessel. Avoid using excessive amounts of TFE tape when installing threaded sensing elements.
- Install systems with threaded NPT connection via wrench flats on the process connection **ONLY**.
- The actual mounting location often depends on the placement of nozzles or openings into the vessel. Do not mount the instrument through a nozzle which exceeds the Cote-Shield element on the sensing element. See Figure 2-1.
- Protect the insulation on the sensing element against cuts and scrapes during installation.

Figure 2-3 provides typical mounting dimensions.

## 2.2 Mounting the Level Control (continued)

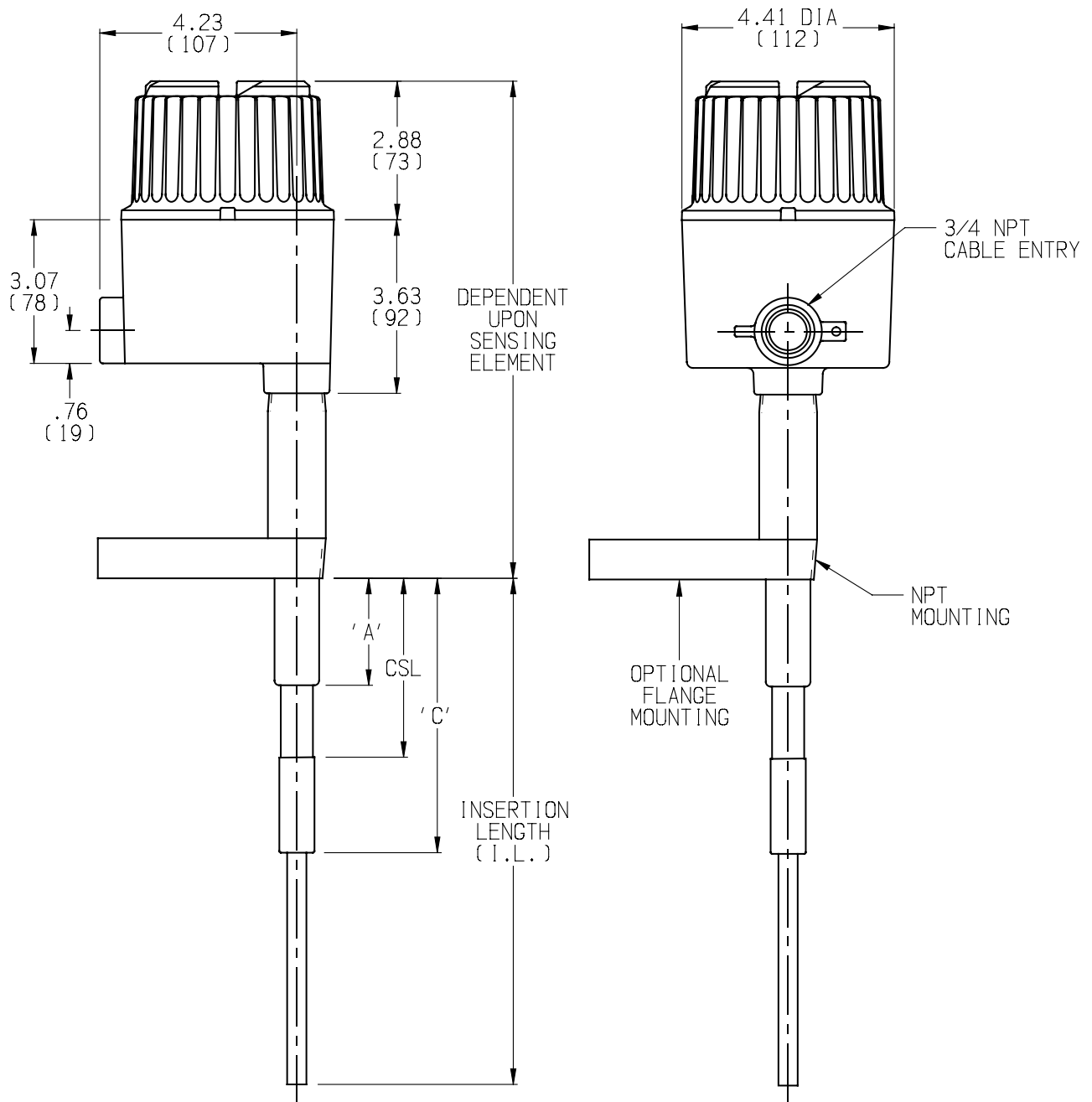


**Figure 2-1**  
*Z-tron IV Level Control Mounting Recommendations*



**Figure 2-2**  
*Z-tron IV Level Control Installation Guidelines*

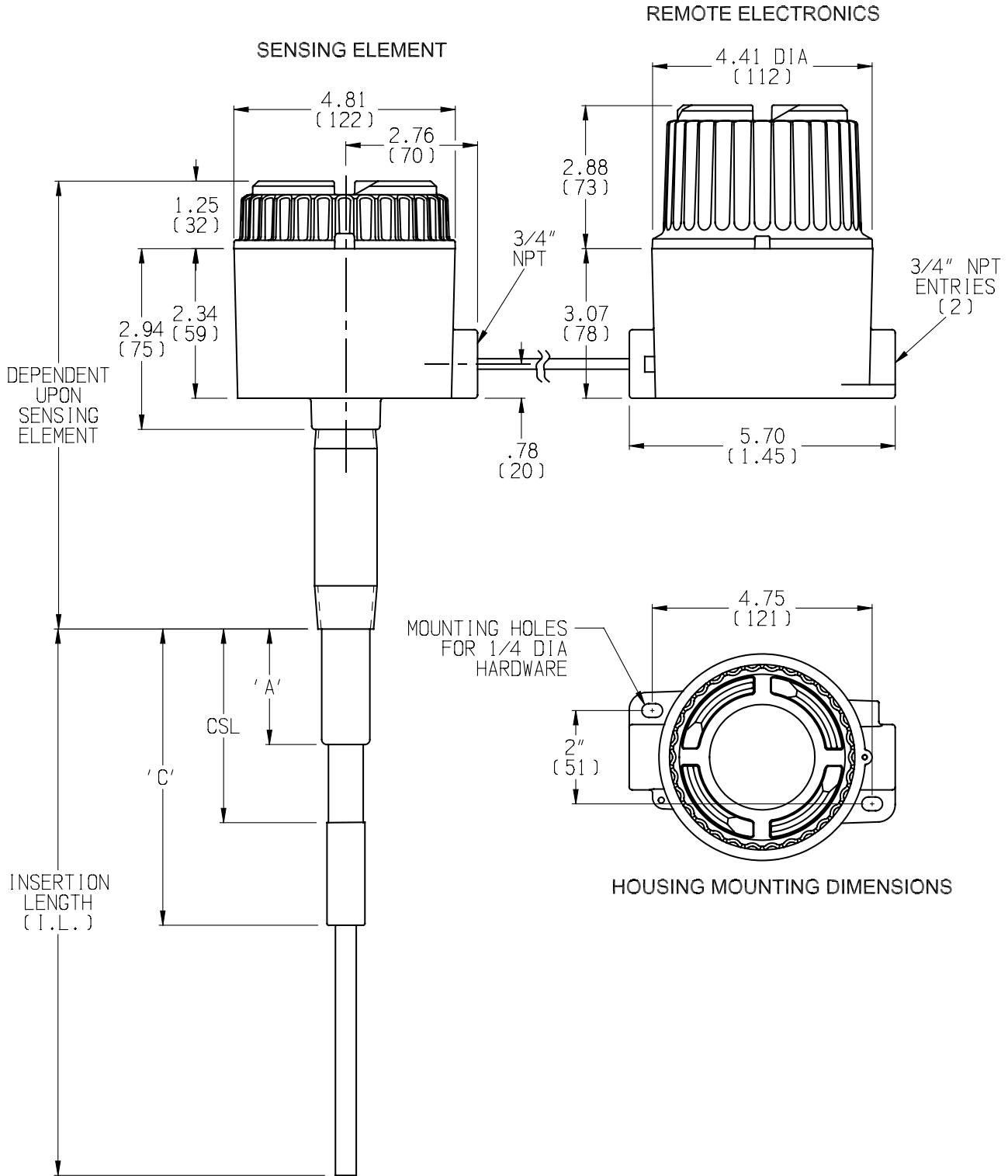
### 2.3 Integral Mounting Dimensions



DIMENSIONS ARE IN INCHES (mm)

**Figure 2-3-1**  
**Mounting Dimensions**

## 2.4 Remote Mounting Dimensions



DIMENSIONS ARE IN INCHES ( mm )

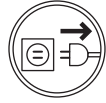
**Figure 2-3-2**  
**Mounting Dimensions**

## 2.5 Power Wiring



### CAUTION

Do not make/break any electrical connections without first disconnecting electrical power at the source.



Ensure that wiring, electrical fittings and conduit connections conform to the electrical codes for the specific location.

**The Z-tron IV level control is a general purpose device and is not agency approved for use in hazardous locations. If agency approval is required, contact your local AMETEK Drexelbrook representative or call 1-800-553-9092.**

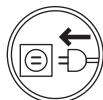
Refer to Figures 2-4-1 and 2-4-2 for the appropriate power wiring and use the following procedure to wire the Z-tron IV level control:



1. Ensure that all power to the wiring is off.
2. Remove the cover.
3. The power connections are made to terminals 1, 2, and 3 on the electronic chassis, using 12 gauge wire (max.).
4. **115 / 230 VAC Only** (Input voltage is field selectable)
  - a. Use jumpers on side of electronic chassis to select input voltage.
  - b. Input voltage jumper selection must match input voltage or electronic chassis may be damaged.
5. The alarm relays are wired as shown in Figure 2-5.
6. Review Checklist:
  - a. Wiring correct.
  - b. Input voltage matches instrument label and jumper selection.
  - c. Proper output connections.
  - d. Use 12 gauge wire max.
7. Replace the cover prior to restoring power.



**Be sure the power wiring and voltage are correct. Improper wiring may cause permanent damage, personal injury, and void the factory warranty!**



8. Apply power.

2.5 Power Wiring (continued)

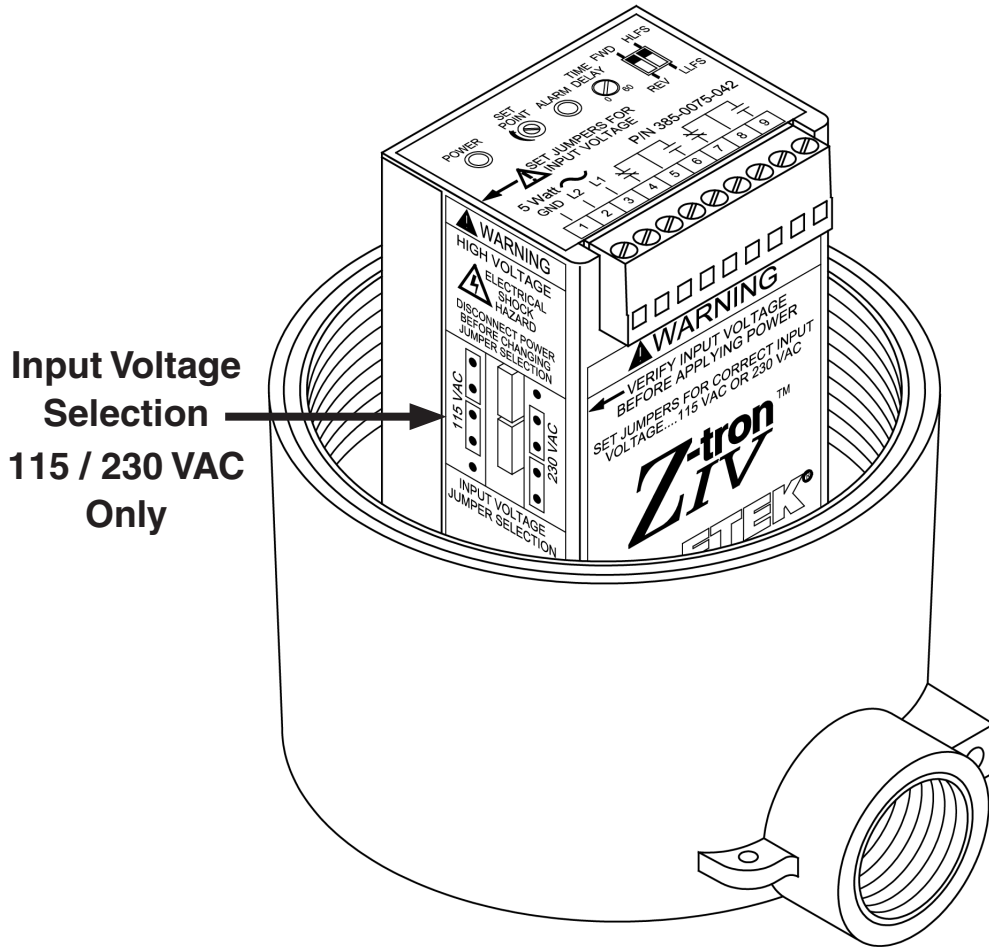
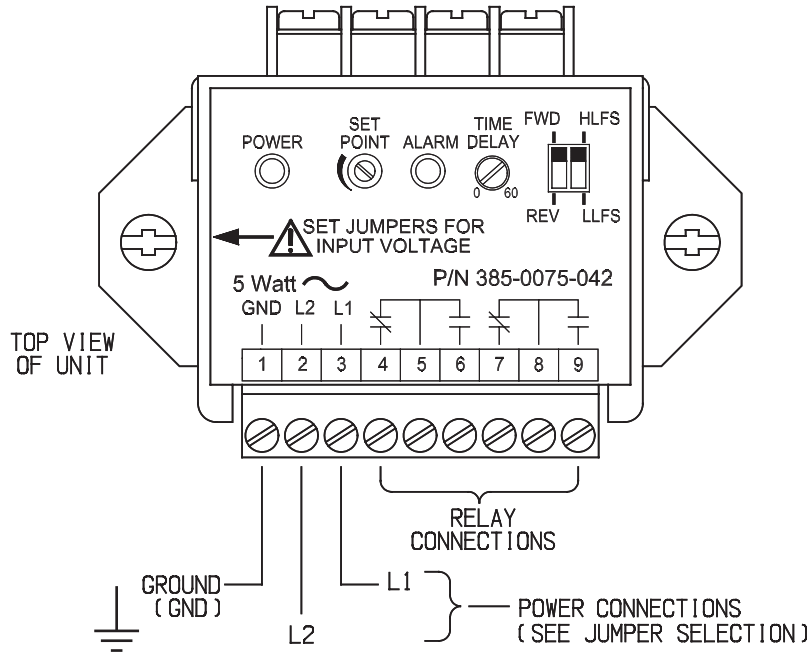


Figure 2-4-1  
 Power Wiring

## 2.5 Power Wiring (continued)

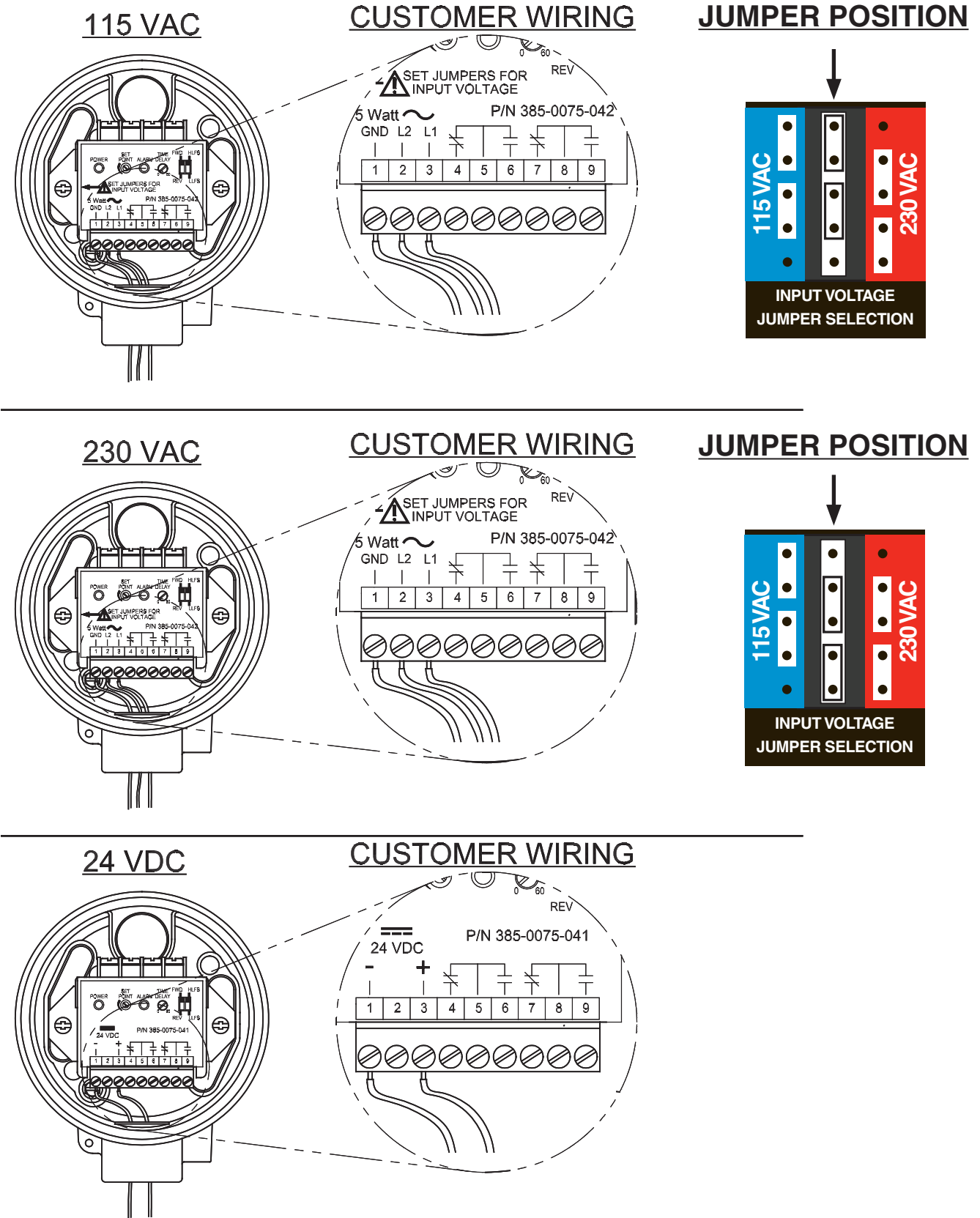


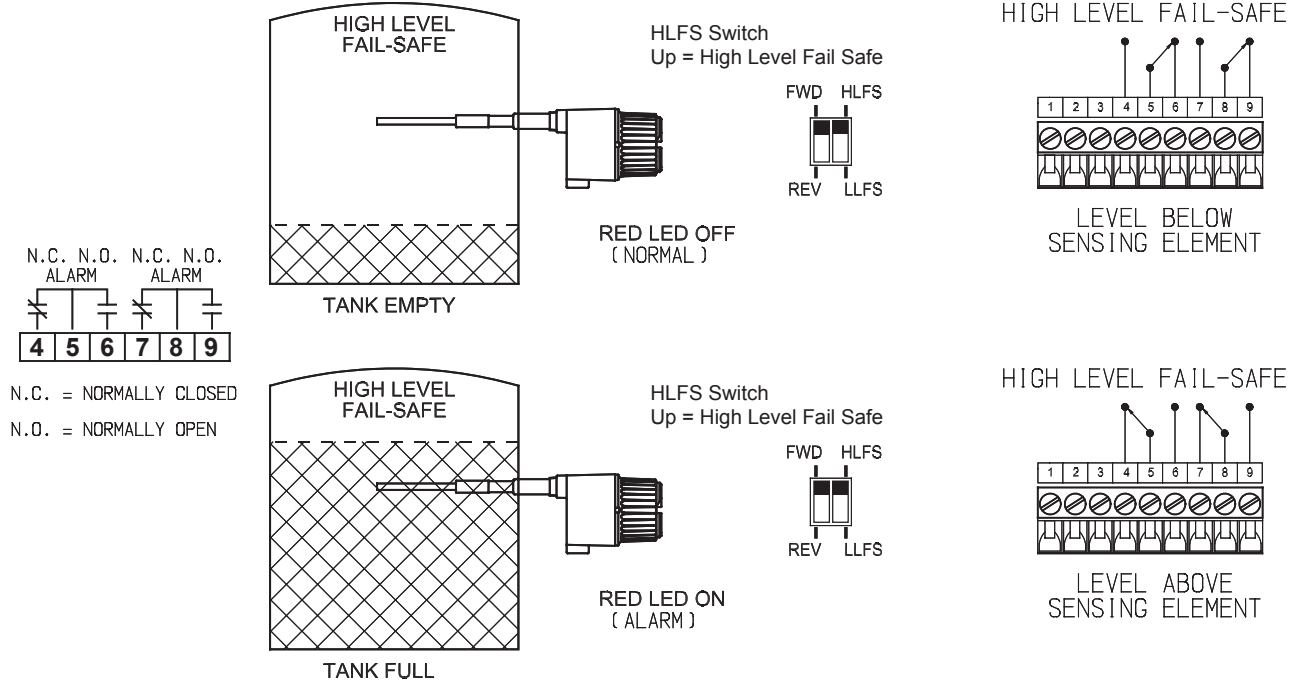
Figure 2-4-2  
Power Wiring



## 2.6 Relay Wiring

Refer to Figure 2-5 for the relay contact wiring. The Z-tron IV relay has double-pole, double-throw (DPDT) dry contacts. The relay serves as a switch and does not provide the power to operate an annunciator or other equipment. All relay connections are made to the terminal strip on the electronic unit. Refer to Figure 3-1 for the Fail Safe Selector Switch location.

### High Level Fail Safe



### Low Level Fail Safe

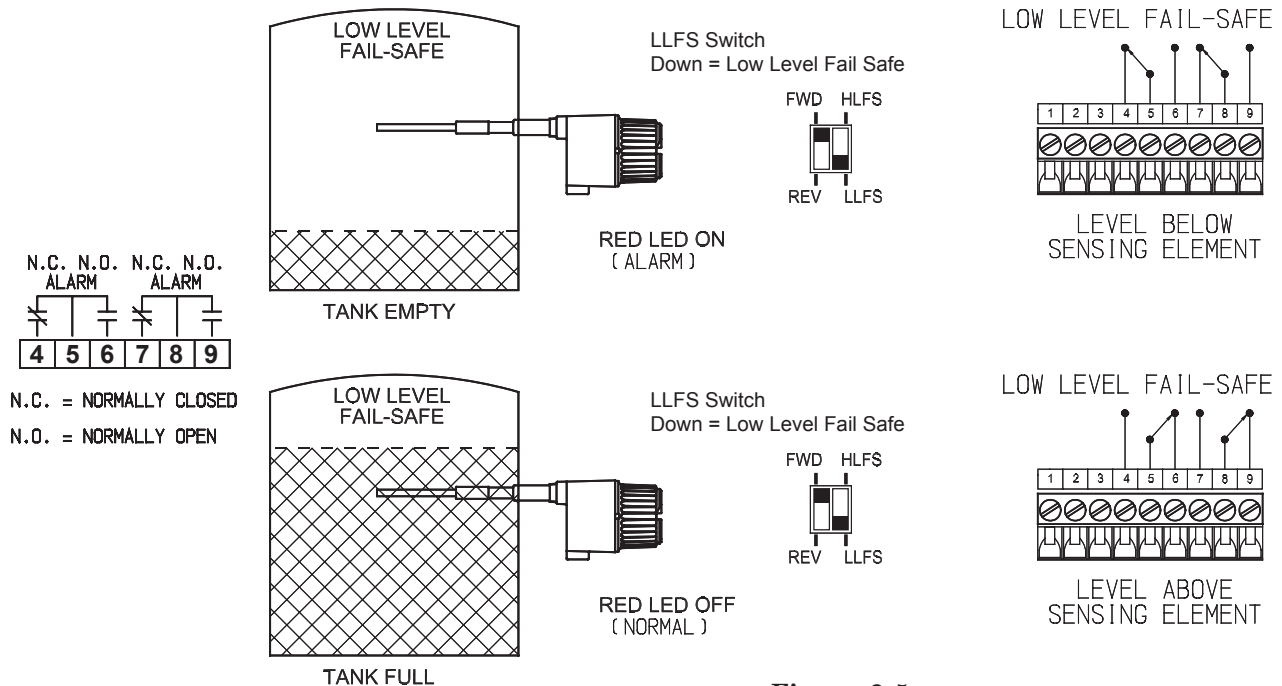


Figure 2-5  
Relay Wiring

## 2.7 Wiring the Sensing Element (Remote)

If the Ztron electronic unit is mounted remotely from the sensing element, the cable connections from the sensing element to the electronic unit are made to the individual terminals on the side opposite the terminal strips. See Figure 2.6 / 2.7.



### NOTE

It is important that the sensing element cable is mechanically separated from the power wiring.

When installing remote-mount electronics, you must use the Drexelbrook supplied coaxial cable. The cable can be a maximum of 50 feet (22.8 meters). Termination kits are available to shorten the cable if necessary.

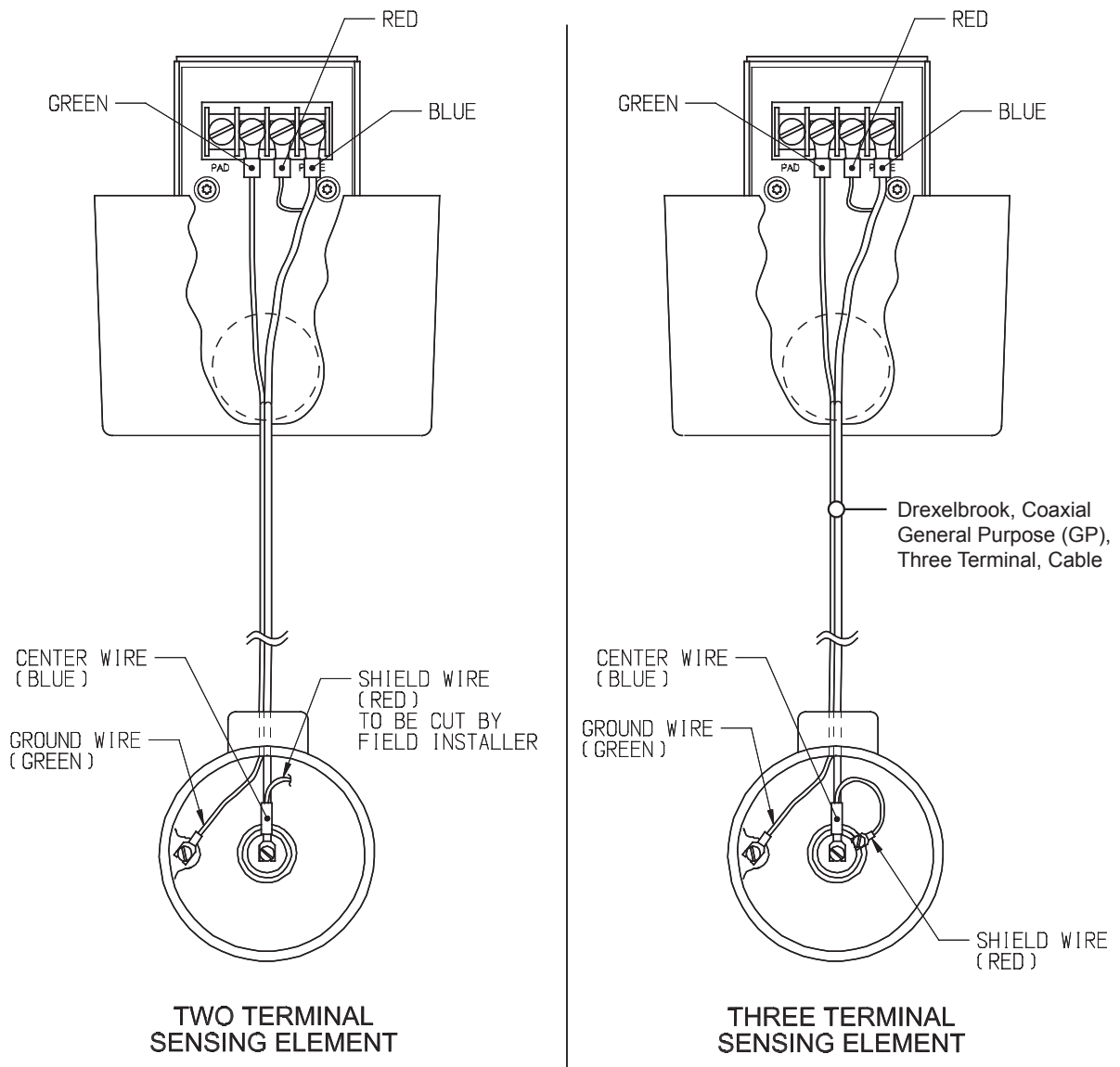
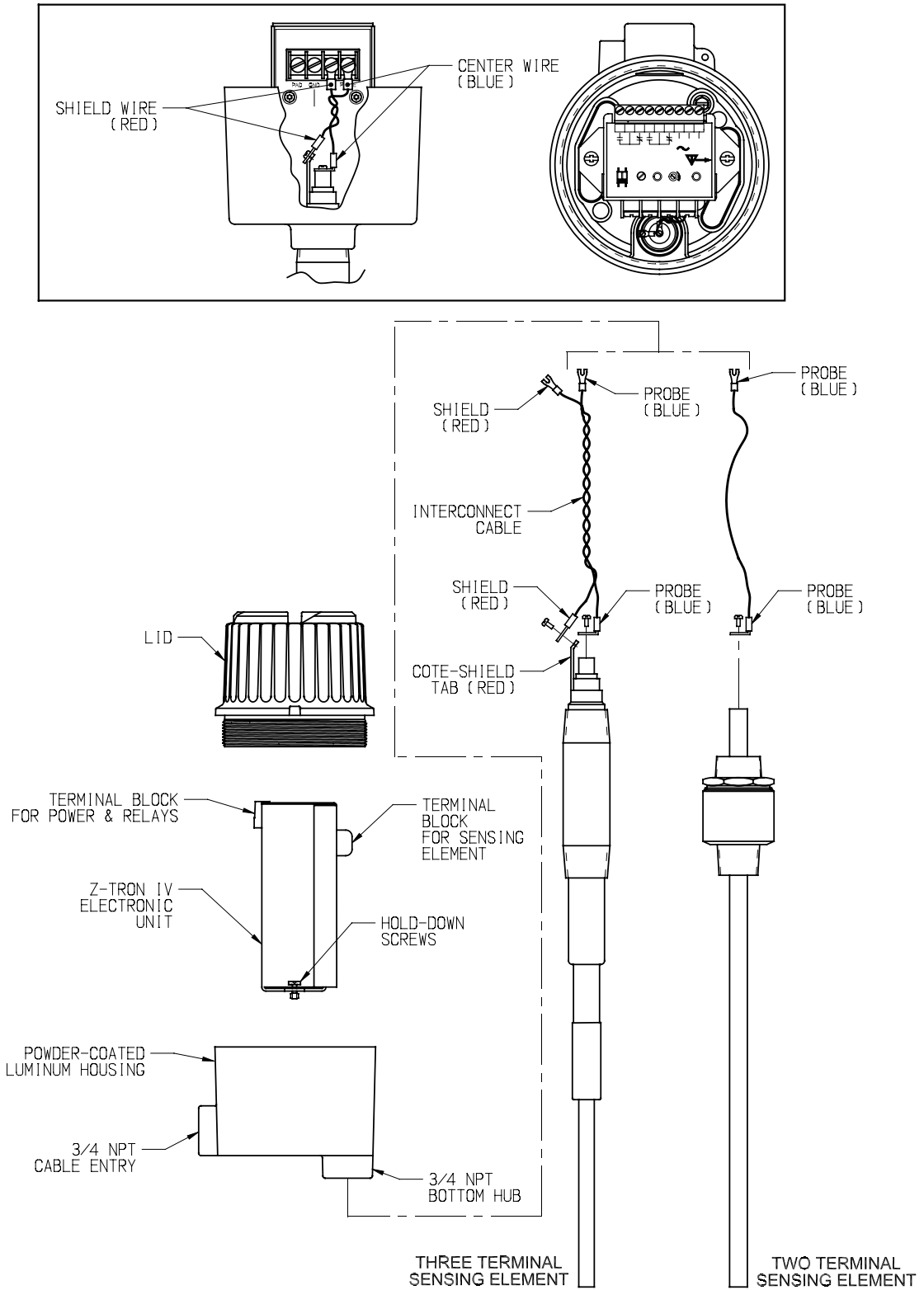


Figure 2-6  
Wiring the Remote Sensing Element

## 2.8 Wiring the Sensing Element (Integral)

**NOTE**

It is important that the sensing element cable is Mechanically separated from the power wiring.



**Figure 2-7**  
*Wiring the Integral Sensing Element*

## Section 3: Operation

This section describes the operating switches of the Z-tron IV level control. Remove the dome lid and use a small screwdriver to set the operating controls.

The green LED (on) indicates power is applied to the unit.

### 3.1 Setpoint Control

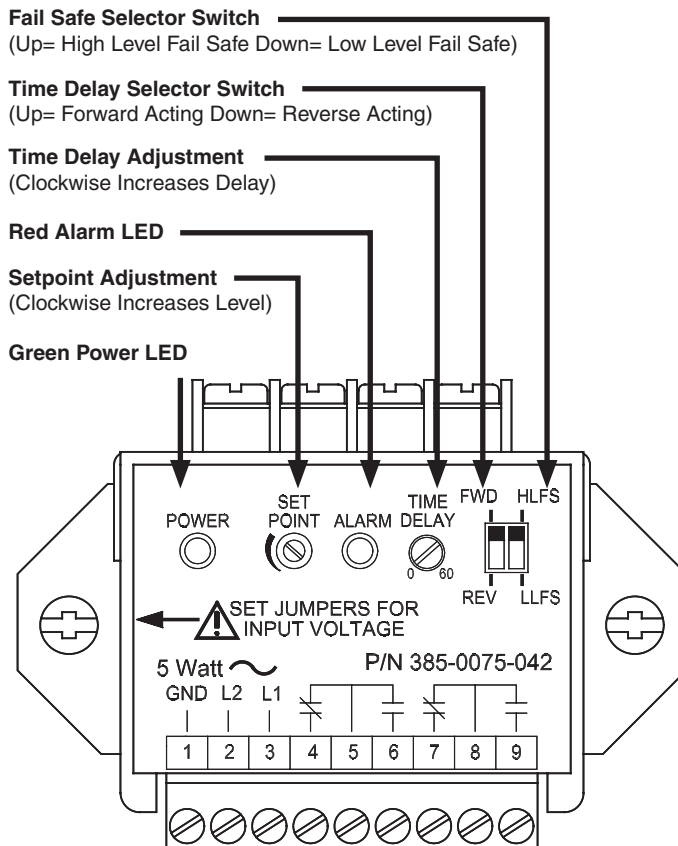
There is a single operating point adjustment used to control the level at which the relay operates. See Figure 3-1.



**This adjustment is an 20-turn potentiometer and does not have a mechanical stop. When in High Level Fail Safe condition, if the red light (LED) is OFF - turn CCW to find SP (relay changes state w/click & light turns ON)... turn CW if red light (LED) is initially ON.**

**In Low Level Fail Safe turn the setpoint adjustment in the opposite direction.**

- Turning the setpoint adjustment clockwise (CW) raises the level at which the relay operates.
- Turning the setpoint counterclockwise (CCW) lowers the level at which the relay operates.
- The red LED (on) indicates that the relay is de-energized and the unit is in the alarm condition.



**Figure 3-1**  
**Z-tron IV Operating Controls and LED**

### 3.2 Time Delay Control

The time delay adjustment is located on top of the instrument, as shown in Figure 3-1. It is used to help stop a repeated relay output due to agitation or waves in the vessel.



#### CAUTION:

**THIS adjustment is a 270° (¾ turn) potentiometer. Do not turn it beyond its mechanical stops or damage to unit may occur.**

The unit is shipped with the Time Delay set to zero (0) seconds. Using a small screwdriver, turn the adjustment clockwise to set anywhere from 0 to 60 seconds.

If the unit is waiting for a change in its alarm state, the alarm LED is blinking and the blinking period is equal to one second. One second period helps to accurately adjust time delay potentiometer to desirable value without necessity of using a stopwatch.

When the alarm LED is blinking, it uses one of two possible blinking modes. See Time Delay Action for definition of modes.

### 3.3 Time Delay Action

Time delay action describes whether the relay contacts are delayed from going into the alarm state or recovering from an alarm state.

- **FWD:** Forward acting delays the system from coming OUT of alarm. Long blinking mode, 0.9 second on and 0.1 second off.
- **REV:** Reverse acting delays the system from going INTO alarm. Short blinking mode, 0.1 second on and 0.9 second off
- The instrument is supplied with the time delay action set in the forward mode position.
- The time delay action may be selected in the field using the left slide switch located on the top of the instrument. See Figure 3-1.

Selecting Time Delay with Slide Switch:

**Forward Acting** - Left Switch UP.

**Reverse Acting** - Left Switch Down.

### 3.4 Failsafe

Failsafe describes the level condition which causes the output relay to de-energize, and determines the condition of the relay upon loss of power or upon the failure of most components.

- The failsafe mode may be selected in the field by changing the position of the right slide switch located on the top of the instrument. See Figure 3-1.
- High Level Failsafe (HLFS) means the relay will de-energize when level is high, indicating high level upon loss of power. (N.O. contacts open/N.C. contacts closed).
- Low Level Failsafe (LLFS) means the relay will de-energize when level is low, indicating low level upon loss of power. (N.O. contacts open/N.C. contacts closed).
- The instrument is supplied in the failsafe mode that is requested when the order is placed. If none specified, it will be shipped as High Level Failsafe (HLFS).

Selecting Failsafe with the Right Slide Switch:

**High Level Failsafe (HLFS)** - Right Switch is up.

**Low Level Failsafe (LLFS)** - Right Switch is down.

### 3.5 Start-up



**Be sure the power wiring and voltage are correct.**

**Improper wiring may cause permanent damage, personal injury, and void the factory warranty!**

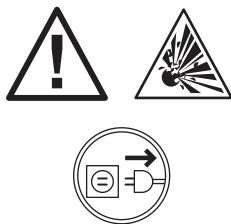
**See Section 2.5.**

## **Section 4**

## Section 4: Calibration

This section contains the calibration information for the Z-tron IV Level Control.

### CAUTION:



**Do not open enclosure cover without verifying area is non-hazardous or make/break any electrical connections without first disconnecting electrical power at the source.**

**Ensure that wiring, electrical fittings and conduit connections conform to the electrical codes for the specific location.**

**The Z-tron IV level control is a general purpose device and is not agency approved for use in hazardous locations. If agency approval is required, contact your local AMETEK Drexelbrook representative or call 1-800-553-909.**

### 4.1 Calibration in Conducting Material



All Z-tron IV controls are factory set to switch in conductive materials [setpoint adjustment is set to full clockwise (CW) position]. No calibration adjustment is necessary.

If this instrument had been previously adjusted for use in a insulating materials, and is now intended for use in a conducting material, use a small screwdriver to turn the setpoint adjustment to the full clockwise (CW) position. No other adjustment is necessary.



## 4.2 Calibration in Insulating Material [Horizontal Mount]

The following procedure is for high level fail-safe. If the unit is set for low level fail-safe LED operation will be opposite:

- 1) Quick Calibration:
  - a) Be sure the material level is well below the sensing element. See Figure 4-1.
  - b) Turn the setpoint adjustment counterclockwise (CCW) until the red LED is on (red LED on indicates that the relay is de-energized and the unit is in the alarm condition).
  - c) Turn setpoint adjustment slowly clockwise (CW) until the relay just operates. (red LED off).
  - d) Turn setpoint adjustment an additional ½ turn CW. Red LED will remain off
  - e) Calibration is complete
  
- 2) Optimal Calibration:
  - a) Be sure the material level is well below the sensing element. See Figure 4-1.
  - b) Turn the setpoint adjustment counterclockwise (CCW) until the red LED is on (red LED on indicates that the relay is de-energized and the unit is in the alarm condition).
  - c) Turn setpoint adjustment slowly clockwise (CW) until the relay just operates. (red LED off).
  - d) Increase the material level until it is well above the sensing element. See Figure 4-2. (LED changes state).
  - e) Note the position of the screwdriver.
  - f) Counting the number of turns, turn the setpoint adjustment slowly clockwise (CW) until the relay once again just operates.



**If less than one turn of the adjustment was observed between the sensing element covered and uncovered, the sensor is not generating enough signal. Consult the factory for further options.**

- g) Turn the adjustment back counterclockwise (CCW) one half the number of turns that were counted.
- h) Record number of turns and save for future calibration reference
- i) Calibration is now complete.

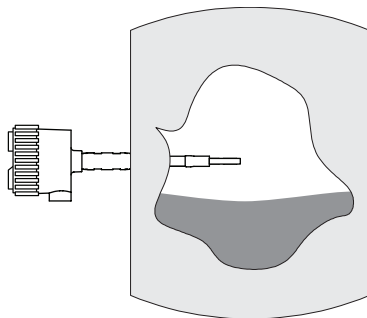
### 4.3 Calibration in Insulating Material [Vertical Mount]

The following procedure is for high level fail-safe. If the unit is set for low level fail-safe LED operation will be opposite:

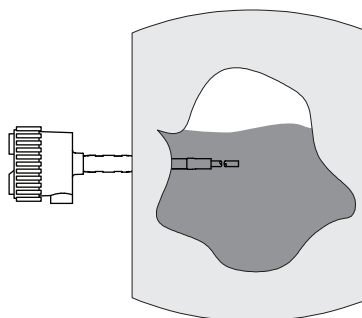
- 1) Be sure the material level is well below the sensing element. **See Figure 4-1.**
- 2) Set the level to a point on the active section of the sensing element where control is desired (3 inches [76.2 mm] of coverage minimum). **See Figure 4-3.**
- 3) Turn the setpoint adjustment counterclockwise (CCW) until the red LED is on (red LED on indicates that the relay is de-energized and the unit is in the alarm condition).
- 4) Turn setpoint adjustment slowly clockwise (CW) until the relay just operates. (red LED off).
- 5) Calibration is complete



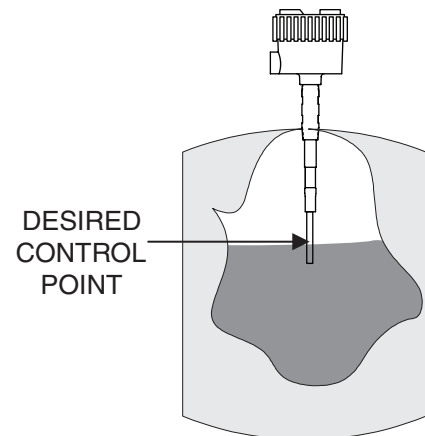
**If dielectric constant or conductivity of material changes, point of operation may change. Consult factory.**



**Figure 4-1**  
*Level Below Horizontal Sensing Element*



**Figure 4-2**  
*Level Above Horizontal Sensing Element*



**Figure 4-3**  
*Level Covering Vertical Sensing Element*

## **Section 5**

## **Section 5: Troubleshooting**

### **5.1 Introduction**

The Z-tron IV Level Control is a solid-state device with no moving parts other than its relays, and requires no maintenance or adjustments. The units are designed to give years of unattended service.

A spare electronic chassis is recommended for every 10 units so that, in case of a failed unit, a critical application will not be delayed while the unit is returned to the factory for repair.

Use the following troubleshooting procedures to check out the Z-tron IV Level Control. If attempts to locate the difficulty fail, notify your local Drexelbrook representative, or call the factory direct at 1-800-527-6297 (US and Canada) or +1 215-674-1234 (International).

### **5.2 Testing Electronic Unit**

It is recommended to begin with Electronic Unit:

1. Verify that green LED is illuminated and the proper voltage is applied to the electronic unit.
2. Change fail-safe selector switch (Fig 3-1). If red LED and relay do not change states, electronic unit has failed.
3. On the back of the electronics unit (side opposite power connections) remove the probe wires from under the blue & red screws.
4. Turn the setpoint adjustment counterclockwise (CCW) until the red LED is on (red LED on indicates that the relay is de-energized and the unit is in the alarm condition).
5. Turn setpoint adjustment slowly clockwise (CW) until the relay just operates. (red LED off).
6. Rotate setpoint adjustment back and forth about this point, observing travel of screwdriver between relay pull-in and relay drop-out. If properly operating, screwdriver should travel less than  $\frac{1}{4}$  turn to operate the relay. If not, electric unit has failed.

### 5.3 Testing Sensing Element

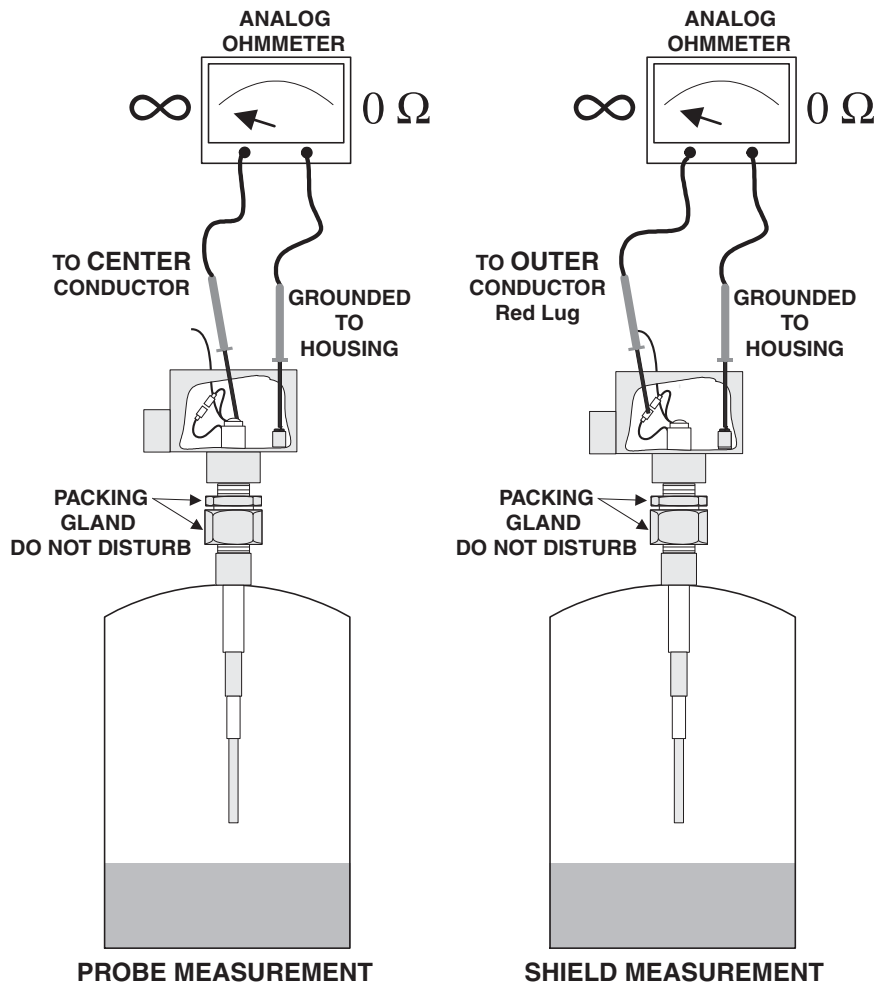
With level below the sensing element:

1. Disconnect remote cable, if applicable.
2. Use an analog ohmmeter<sup>1</sup> that is set to the R x 1K ohm scale. Measure the resistances between each pair of sensing element connections. See Figure 5-1. Record values in Table.
  - a. If the process material is conductive, it is normal to measure some resistance between sensing element connections. The lowest permissible resistance values are:

Center Conductor to Housing	1500 ohms.
Center Conductor to Cote Shield	750 ohms.
Cote Shield to Housing	750 ohms.
3. Clean sensing element and repeat resistance measurements with the sensing element external to the vessel.
  - a. A clean sensing element should measure an open circuit on all resistance tests.
  - b. If resistance values increase to an open circuit the resistance was installation or coating related. The most common causes are:
    - i. Cote Shield element does not extend sufficiently into the vessel. Verify the CoteShield element extends at least 2" into the vessel and past wall build-up.
    - ii. Extremely conductive coating on the sensing element. This may require changing the sensing element or electronics. Contact the factory for recommendations.
    - iii. Sensing element is touching vessel. A resistance reading of less than 10 ohms to ground (sensing element housing or tank) is usually due to a metal-to-metal short circuit. Verify that the sensing element is not touching any vessel structure.
  - c. If the sensing element still shows resistance between terminals of less than 10K ohms, it is possible that moisture is present internal to the sensing element. It may be possible to dry the sensing element until the resistance increases to a value in excess of 10K ohms. However this is an indication the integrity of the sensing element has been compromised. Contact the factory for recommendations.

<sup>1</sup>A digital ohmmeter will often produce a resistance measurement that is higher than the actual value.

5.3 Testing Sensing Element (continued)



<b>Sensing Element in Vessel</b>		
Center Conductor to Housing	_____	Ohms
Center Conductor to Cote Shield	_____	Ohms
Cote Shield to Housing	_____	Ohms
<b>Sensing Element Cleaned</b>		
Center Conductor to Housing	_____	Ohms
Center Conductor to Cote Shield	_____	Ohms
Cote Shield to Housing	_____	Ohms

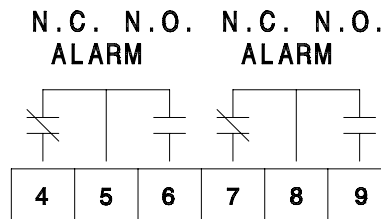
*Figure 5-1*  
**Checking the Sensing Element**  
*Center = Probe*  
*Outer = Shield*  
*Housing = Ground*

## 5.4 Testing Relay Circuits

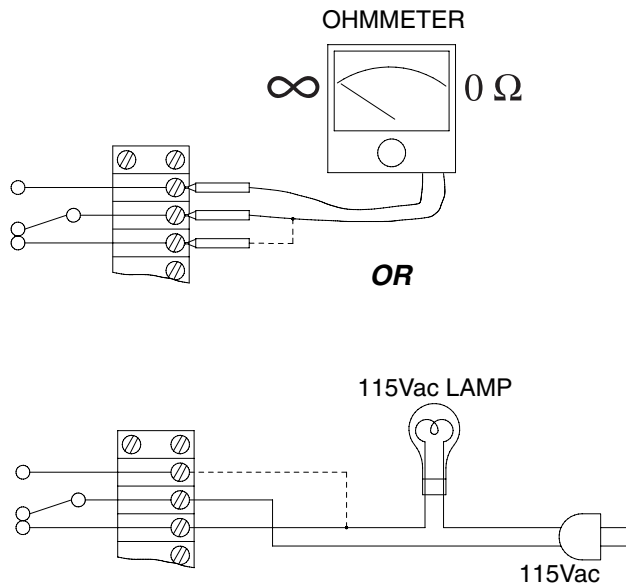
The relay circuits consist of a double-pole double-throw relay brought out to a terminal strip. Figure 5-2 shows the relay when the unit is in an alarm condition

Using an ohmmeter, perform the following steps to check out the relay circuits:

1. Apply power to the unit
2. Connect ohmmeter as shown in Figure 5-3.
3. Change fail-safe switch position. Ref Figure 3-1
4. Relay should change state. Ohmmeter should change from measuring an open circuit to short circuit or from measuring a short circuit to measuring an open circuit. An audible click may be observed if the background noise is low.
5. Repeat until all 4 pairs have been checked.
6. If any pair does not show a change in resistance the unit has failed.



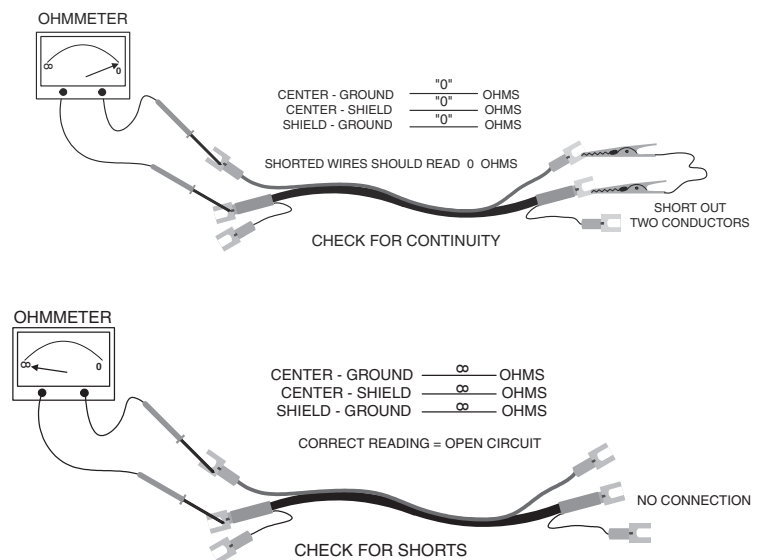
**Figure 5-2**  
**Relay Circuit Operation**



**Figure 5-3**  
**Relay Circuit Troubleshooting**

## 5.5 Testing Remote Cable

1. Disconnect remote cable from electronic unit and sensing element.
2. Using an ohmmeter measure the resistances as shown in Figure 5.4
  - A. Check for shorts.
    - i. Connect ohmmeter to cable center wire and ground wire. Measure resistance as shown.
    - ii Move ohmmeter leads and repeat for all measurements shown.
    - iii. If resistance is less than 100 k-ohms cable has failed
  - B. Check for continuity.
    - i. Short center wire to ground wire and measure resistance as shown. Should be close to 0 ohms
    - ii. Short center wire to shield and repeat.
    - iii. If resistance is greater than 10 ohms cable has failed



**Figure 5-4**  
**Testing Remote Cable**



## 5.6 Possible Problems and Causes

Problem	Possible Cause	Solution
1. Instrument indicates alarm at all times.	<ul style="list-style-type: none"> <li>a. Severe coating build on sensing element (HLFS).</li> <li>b. Sensing element not “seeing” material (LLFS) due to fill angle.</li> <li>c. Sensing element cable damaged</li> <li>d. Defect in sensing element.</li> <li>e. Loss of power.</li> <li>f. Improper relay wiring.</li> <li>g. Improper calibration.</li> <li>h. Electronic unit malfunction.</li> <li>i. Shorted sensor.</li> <li>j. Water in housing or conduit.</li> </ul>	<ul style="list-style-type: none"> <li>a. Need longer Cote-Shield. Consult factory.</li> <li>b. Need longer insertion length. Consult factory.</li> <li>c. See Section 5.XX</li> <li>d. See Section 5.3.</li> <li>e. Check power wiring. See Figure 2-4. f. See Section 2.5. g. See Section 4.</li> <li>h. See Section 5.2.</li> <li>i. See Section 5.3.</li> <li>j. Consult factory.</li> </ul>
2. Instrument never indicates alarm.	<ul style="list-style-type: none"> <li>a. Severe coating build-up on sensing element (LLFS).</li> <li>b. Sensing element not “seeing” material (HLFS) due to fill angle.</li> <li>c. Improper wiring.</li> <li>d. Improper calibration.</li> <li>e. Electronic unit malfunction.</li> </ul>	<ul style="list-style-type: none"> <li>a. Need longer Cote-Shield. Consult factory.</li> <li>b. Need longer insertion length. Consult factory.</li> <li>c. See Section 2.</li> <li>d. See Section 4.</li> <li>e. See Section 5.2.</li> </ul>
3. Instrument can't be calibrated.	<ul style="list-style-type: none"> <li>a. Improper wiring.</li> <li>b. Insufficient signal from sensing element.</li> <li>c. Setpoint is beyond the tuning range of the electronics.</li> <li>d. Electronic unit malfunction</li> <li>e. Sensor covered with conducting material.</li> </ul>	<ul style="list-style-type: none"> <li>a. See Section 2.</li> <li>b. Need longer insertion length. Consult factory.</li> <li>c. Consult factory.</li> <li>e. See Section 5.2.</li> </ul>
4. Instrument gives a false alarm.	<ul style="list-style-type: none"> <li>a. Improper calibration.</li> <li>b. Loose wiring.</li> <li>c. Electronic unit malfunction.</li> <li>d. Time delay required.</li> <li>e. Intermittent short of sensor.</li> </ul>	<ul style="list-style-type: none"> <li>a. See Section 4.</li> <li>b. See Section 2.</li> <li>c. See Section 5.2.</li> <li>d. Consult factory.</li> <li>e. See Section 5.3.</li> </ul>
5. Instrument operates intermittently.	<ul style="list-style-type: none"> <li>a. Improper calibration.</li> <li>b. Loose wiring.</li> <li>c. Electronic unit malfunction.</li> <li>d. Dielectric (k) of material is too low.</li> </ul>	<ul style="list-style-type: none"> <li>a. See Section 4.</li> <li>b. See Section 2.</li> <li>c. See Section 5.2.</li> <li>d. Need high sensitivity unit. Consult factory.</li> </ul>

## 5.7 Factory Assistance

AMETEK Drexelbrook can answer any questions about The Z-tron IV series instrument. Call Customer Service at 1-800-553-9092 (US and Canada) or +1 215 674-1234 (International).

If you require assistance and attempts to locate the problem have failed:

Contact your local Drexelbrook representative,



**Telephone** the Service department toll-free:

- 1-800-527-6297 (US and Canada)
- +1 215 674-1234 (International)

**FAX:** Service Department + 215-443-5117

**E-Mail:** [drexelbrook.service@ametek.com](mailto:drexelbrook.service@ametek.com)

Please provide the following information:

- Instrument Model Number
- Sensing Element Model Number and Length
- Original Purchase Order Number
- Material being measured
- Temperature
- Pressure
- Agitation
- Brief description of the problem
- Checkout procedures that have failed

## 5.8 Field Service

Trained Field Service Engineers are available on a time-plus-expense basis to assist in start-ups, diagnosing difficult application problems, or in-plant training of personnel. Contact the service department for further details.

## 5.9 Customer Training

Periodically, AMETEK Drexelbrook instrument training seminars for customers are held at the factory. These sessions are guided by Drexelbrook engineers and specialists, and provide detailed information on all aspects of level measurement, including theory and practice of instrument operation. For more information call 215-674-1234.



## 5.10 Equipment Return

In order to provide the best service, any equipment being returned for repair or credit must be pre-approved by the factory.

In many applications, sensing elements are exposed to hazardous materials.

- **OSHA mandates** that our employees be informed and protected from hazardous chemicals.
- **Material Safety Data Sheets (MSDS)** listing the hazardous materials to which the sensing element has been exposed **MUST** accompany any repair.
- It is your responsibility to fully disclose all chemicals and **decontaminate** the sensing element.



**To obtain a return authorization (RA#)**, contact the Service department at 1-800-527-6297 (US and Canada) or + 215-674-1234 (International).

- Please provide the following information:
- Model Number of Return Equipment
- Serial Number
- Original Purchase Order Number
- Process Materials to which the equipment has been exposed.
- MSDS sheets for any hazardous materials
- Billing Address
- Shipping Address
- Purchase Order Number for Repairs
- Please include a purchase order even if the repair is under warranty. If repair is covered under warranty, you will not be charged.

Ship equipment freight prepaid to:

AMETEK-DREXELBROOK.  
205 KEITH VALLEY ROAD  
HORSHAM, PA 19044-1499  
COD shipments will not be accepted.

## Section 6: Specifications

### Power Requirements:

AC Units - Field Adjustable:  
95-145 VAC, 50/60 Hz, 1 Watt  
215-265 VAC, 50/60 Hz, 1 Watt

DC Units:  
24 VDC Unit: 19-29 VDC input, 1 Watt

### Sensitivity:

0.3pF or less

### Operating Point Range:

0 - 80 pF (20 Turn Pot / 4 pF per Turn)  
Extended range with external pad capacitor, Pad ratio 1:1

### Load Resistance:

Center to Ground, 1500 Ohms  
Center to Shield, 750 Ohms  
Shield to Ground, 750 Ohms

### Failsafe:

Field adjustable to either High-Level Fail-Safe (HLFS)  
or  
Low-Level Fail-Safe (LLFS)

### Output:

DPDT relay closure

### Contact Rating:

5A @ 120 Vac non-inductive  
2A @ 230 Vac non-inductive

### Ambient Temperature:

-40°F to 145°F (-40°C to 60°C)

### Temperature Effect:

0.5pF/50°F

### Line Voltage Effect:

0.2pF/20V @ 120 Vac

### Stability:

0.15pF/6 mo. maximum shift

### Spark Protection:

100 Amp

### Mounting: (Probe Dependant)

¾-inch NPT (Typical)

## **Section 6: Specifications (Continued)**

### **Housing:**

The standard housing meets the following classifications:

Nema 1 General-Purpose  
Nema 2 Drip-Tight  
Nema 3 Weather-Resistant  
Nema 4 Waterproof  
Nema 5 Dust-Tight  
Nema 12 Industrial Use

FM approval on housing only. If agency approval is required, use the Drexelbrook PXL The Point™ instrument for point level control.

### **Time Delay:**

0-60 seconds (3/4 Turn Pot) 270° Potentiometer

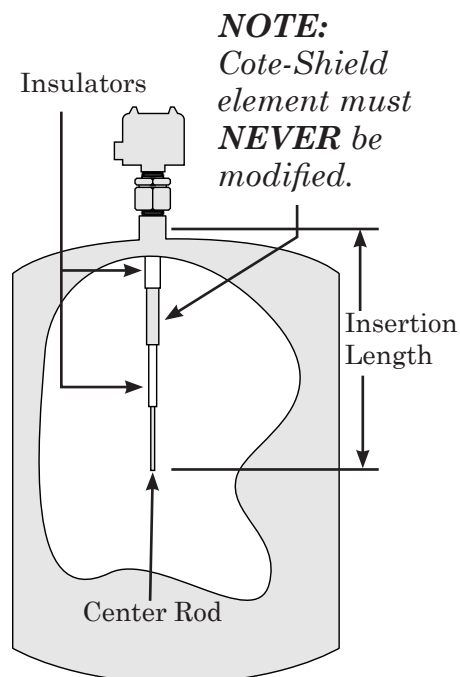
### **Approvals**

FM / FMC 3810 General Purpose

## Appendix A: Shortening or Lengthening the Sensing Element



**CAUTION:**  
*The insulation length of either **Flush Sensing Elements** or **Insulated Sensing Elements** can **NOT** be changed. **Cable Sensing Elements** can only be shortened. Instructions are included with each unit.*



**Note:**  
*Any changes to probe length after calibration requires re calibration to ensure proper operation.*

### The Need

Sometimes your application calls for probe lengths other than the standard 18-inch or longer insertion lengths supplied. Shortening the sensing element is quite simple and can be done in the field. Lengthening the sensing element, however, is more difficult because the metal rod, typically 316 SS, must be welded.

### Before making any Adjustments:

- 1) Read the following instructions thoroughly.
- 2) Remove power.
- 3) Disconnect the electronics.
- 4) Protect electronics from any static discharge.
- 5) Protect electronics from any heat.

### Shortening

The bare metal center rod of the sensing element can be shortened with a hacksaw. Be careful not to cut either of the two insulators. See Figure on this page.

In applications using conductive or water-based materials, shortening is not a problem. Leave a minimum bare metal center rod length of two (2) inches.

For dry granular materials, such as powder, sand, corn, clinker, etc., you must leave a minimum bare metal center rod length of eight (8) inches. Consult the factory before shortening beyond this point.

### Lengthening

To lengthen the sensing element, an extension rod can be welded onto the end of the bare metal center rod. Make sure that the extension rod is the same metal as the sensing element. Disconnect electronics before welding

An alternate option is to add a pipe coupling and a section of metal pipe or rod after threading the tip of the sensing element. In this case, the metal pipe need not be identical to the metal of the sensing element.

**TERMS AND CONDITIONS OF SALE**

**GENERAL:** ALL ORDERS ARE SUBJECT TO THE FOLLOWING TERMS AND CONDITIONS. ANY ACCEPTANCE OF ANY OFFER OF BUYER FOR ANY GOODS OR SERVICES IS CONDITIONED UPON THESE TERMS AND CONDITIONS, AND SELLER OBJECTS TO ANY ADDITIONAL OR DIFFERENT TERMS PROPOSED BY BUYER IN ANY DOCUMENT, WHICH SHALL NOT BE BINDING UPON SELLER. No salesman or other party is authorized to bind the AMETEK DREXELBROOK Division of AMETEK, Inc. (hereinafter "Seller") by any agreement, warranty, statement, promise, or understanding not herein expressed, and no modifications shall be binding on Seller unless the same are in writing and signed by an executive officer of Seller or his or her duly authorized representative. Verbal orders shall not be executed until written notification has been received and acknowledged by Seller.

**QUOTATIONS:** Written quotations are valid for thirty (30) days unless otherwise stated. Verbal quotations expire the same day they are made.

**PRICES:** All prices and terms are subject to change without notice. Buyer-requested changes to its order ("Orders"), including those affecting the identity, scope and delivery of the goods or services, must be documented in writing and are subject to Seller's prior approval and adjustments in price, schedule and other affected terms and conditions. Orders requiring certified test data in excess of commercial requirements, are subject to a special charge.

**ORDER ACCEPTANCE:** All Orders are subject to final approval and acceptance by Seller at its office located at 205 Keith Valley Road, Horsham, Pennsylvania 19044.

**TERMS OF PAYMENT:** Seller's standard terms of payment for Buyers who qualify for credit are net thirty (30) days from date of invoice. All invoices must be paid in United States dollars.

**CREDIT:** Seller reserves the right at any time to revoke any credit extended to Buyer or otherwise modify terms of payment if Buyer fails to pay for any shipments when due or if in Seller's opinion there is a material adverse change in Buyer's financial condition. Seller may, at its option, cancel any accepted Order if Buyer fails to pay any invoices when due.

**DELIVERY:** Shipments are F.O.B place of manufacture ("Shipping Point") and the Buyer shall pay all freight, transportation, shipping, duties, fees, handling, insurance, storage, demurrage, or similar charges from Shipping Point. Delivery of goods to common carrier shall constitute delivery and passing of title to the Buyer, and all risk of loss or damage in transit shall be borne by Buyer. Any claims or losses for damage or destruction after such delivery shall be the responsibility of Buyer.

Seller reserves the right to make delivery in installments which shall be separately invoiced and paid for when due, without regard to subsequent deliveries. Delay in delivery of any installment shall not relieve Buyer of its obligation to accept remaining deliveries.

Acknowledged shipping dates are approximate only and based on prompt receipt of all necessary information from Buyer and Buyer's compliance with terms of payment.

**TAXES:** All sales, excise and similar taxes which Seller may be required to pay or collect with respect to the goods and/or services covered by any Order, shall be for the account of the Buyer except as otherwise provided by law or unless specifically stated otherwise by Seller in writing.

**TERMINATION AND HOLD ORDERS:** No Order may be terminated by Buyer except upon written request by Buyer and approval by Seller, and if said request is approved by Seller, under the following conditions: (1) Buyer agrees to accept delivery of all of the units completed by Seller through the workday on which Seller receives the written termination request; (2) Buyer agrees to pay to Seller all direct costs and expenses applicable to the portion of the Order that is incomplete.

**WARRANTY:**

A. **Hardware:** Seller warrants its goods against defects in materials and workmanship under normal use and service for one (1) year from the date of invoice.

B. **Software and Firmware:** Unless otherwise specified, Seller warrants for a period of one (1) year from date of invoice that standard software or firmware, when used with Seller specified hardware, shall perform in accordance with Seller's published specifications. Seller makes no representation or warranty, expressed or implied, that the operation of the software or firmware shall be uninterrupted or error-free, or that functions contained therein shall meet or satisfy the Buyer's intended use or requirements.

C. **Services:** Seller warrants that services, including engineering and custom application, whether provided on a fixed cost or time and material basis, shall be performed in accordance with generally accepted industry practices.

D. **Remedies:** Seller's liability under this section is restricted to replacing, repairing, or issuing credit (at Seller's option) for any returned goods and only under the following conditions: (1) Seller must be promptly notified, in writing, as soon as possible after the defects have been noted by the Buyer, but not later than (1) year from date of invoice from Seller; (2) The defective goods are to be returned to the place of manufacture, shipping charges prepaid by the Buyer; (3) Seller's inspection shall disclose to its satisfaction that the goods were defective in materials or workmanship at the time of shipment; (4) Any warranty service (consisting of time, travel and expenses related to such services) performed other than at Seller's factory, shall be at Buyer's expense.

E. **Repaired/Reconditioned Goods:** As to out-of-warranty goods which Seller has repaired or reconditioned, Seller warrants for a period of sixty (60) days from date of its invoice only new components replaced in the most recent repair/reconditioning.

F. **Returns and Adjustments:** No goods may be returned unless authorized in advance by Seller and then only upon such conditions to which Seller may agree. Buyer must obtain an RMA (Return Material Authorization) number from Seller prior to any return shipment and such RMA number must appear on the shipping label and packing slip. Buyer shall be responsible for the returned goods until such time as Seller receives the same at its plant and for all charges for packing, inspection, shipping, transportation, or insurance associated with returned goods. In the event that credit for returned goods is granted, it shall be at the lesser of the then current prices or the original purchase price. Claims for shortage or incorrect material must be made within five (5) days after receipt of shipment.

**ALL OTHER WARRANTIES, FOR ANY OF SELLER'S GOODS OR SERVICES, WHETHER ORAL, WRITTEN, EXPRESS, IMPLIED, STATUTORY OR OTHERWISE, INCLUDING WITHOUT LIMITATION ANY IMPLIED WARRANTY OF MERCHANTABILITY OR FITNESS FOR PURPOSE ARE EXCLUDED.**

**INTELLECTUAL PROPERTY:** Seller's sale of goods or provision of related documentation or other materials to Buyer shall not transfer any intellectual property rights to Buyer unless Seller specifically agrees to do so in writing. Seller shall retain ownership of all applicable patents, trademarks, copyrights and other intellectual property rights. Buyer shall not use, copy or transfer any such items in violation of Seller's intellectual property rights or applicable law, or for any purposes other than that for which the items were furnished.

Seller shall defend any lawsuit brought against the Buyer based on a claim that the design or construction of the goods sold hereunder by Seller infringe any United States or Canadian Patent, Copyright or Mask Work Registration, provided that Buyer promptly notifies Seller of such claim in writing and further provided that, at Seller's expense, (1) Buyer gives Seller the sole right to defend or control the defense of the suit or proceeding, including settlement, and (2) Buyer provides all necessary information and assistance for that defense. In the event of a charge of infringement, Seller's obligation under the agreement shall be fulfilled if Seller, at its option and expense, either (i) settles such claim; (ii) procures for Buyer the right to continue using such goods; (iii) replaces or modifies goods to avoid infringement; or (iv) accepts the return of any infringing goods and refunds their purchase price; or (iv) defends against such claim.

If Buyer furnishes specifications or designs to Seller, the obligations of Seller set forth above shall not apply to goods made by Seller using such specifications or designs, and Buyer shall defend, indemnify and hold Seller harmless against any third party claims for infringement which arise out of Seller's use of specifications or designs furnished by Buyer.

**SOFTWARE LICENSE:** If goods purchased hereunder include software ("Software"), Buyer may use the Software only as part of the goods. Buyer may not use, copy, or transfer any of the Software except as may be permitted under the applicable License Agreement provided with the goods. Buyer's right to use, copy or transfer the Software shall terminate upon termination of Buyer's right to use the goods.

**PACKAGING/WEIGHTS AND DIMENSIONS:** Buyer specified packing or marking may be subject to additional charges not otherwise included in the price of the goods. Published weights and dimensions are estimates or approximate only and are not warranted.

**FORCE MAJEURE:** Seller shall not be responsible for delays in delivery or any failure to deliver due to causes beyond Seller's control, including but not limited to the following items: acts of God, war, terrorism, mobilization, civil commotion, riots, embargoes, domestic or foreign governmental regulations or orders, governmental priorities, port congestion, acts of the Buyer, its agents or employees, fires, floods, strikes, lockouts and other labor difficulties, shortages of or inability to obtain shipping space or transportation, inability to secure fuel, supplies or power at current prices or on account of shortages thereof, or due to limitations imposed by the extent of availability of Seller's normal manufacturing facilities.

If a delay excused per the above extends for more than ninety (90) days and the parties have not agreed upon a revised basis for continuing providing the goods or services at the end of the delay, including adjustment of the price, then Buyer, upon thirty (30) days' prior written notice to Seller may terminate the Order with respect to the unexecuted portion of the goods or services, whereupon Buyer shall promptly pay Seller its reasonable termination charges upon submission of Seller's invoices thereof.

**LIMITATION OF LIABILITY:** Seller's liability for any claim of any kind, except infringement of intellectual property rights, shall not exceed the purchase price of any goods or services which give rise to the claim. **SELLER SHALL IN NO EVENT BE LIABLE FOR BUYER'S MANUFACTURING COSTS, LOST PROFITS, LOSS OF USE OF THE GOODS OR SERVICES, COST OF CAPITAL, COST OF SUBSTITUTE GOODS, FACILITIES, SERVICES OR REPLACEMENT POWER, DOWNTIME COSTS, CLAIMS OF BUYER'S CUSTOMERS FOR DAMAGES, OR OTHER SPECIAL, PROXIMATE, INCIDENTAL, INDIRECT, EXEMPLARY OR CONSEQUENTIAL DAMAGES.** Any action against Seller must be brought within eighteen (18) months after the cause of action accrues. These disclaimers and limitations of liability shall apply regardless of the form of action, whether in contract, tort or otherwise, and further shall extend to the benefit of Seller's vendors, appointed distributors and other authorized resellers as third-party beneficiaries.

**PROHIBITION FOR HAZARDOUS USE:** Goods sold hereunder generally are not intended for application in and shall not be used by Buyer in the construction or operation of a nuclear installation or in connection with the use or handling of nuclear material, or for any hazardous activity or critical application, where failure of a single component could cause substantial harm to persons or property, unless the goods have been specifically approved for such a use or application. Seller disclaims all liability for any loss or damage resulting from such unauthorized use and Buyer shall defend, indemnify and hold harmless the Seller against any such liability, whether as a result of breach of contract, warranty, tort (regardless of the degree of fault or negligence), strict liability or otherwise.

**EXPORT CONTROL:** Buyer shall comply with all export control laws and regulations of the United States, and all sales hereunder are subject to those laws and regulations. Seller shall not be named as shipper or exporter of record for any goods sold hereunder unless specifically agreed to in writing by Seller. At Seller's request, Buyer shall furnish Seller with end-use and end-user information to determine export license applicability. Buyer warrants, in accordance with U.S. Export Law, that goods sold hereunder shall not be destined for facilities or activities involving nuclear, chemical or biological weapons, or related missile delivery systems in named prohibited regions or countries.

**GOVERNING LAW:** Seller intends to comply with all laws applicable to its performance under any order. All matters relating to interpretation and effect of these terms and any authorized changes, modifications or amendments thereto shall be governed by the laws of the Commonwealth of Pennsylvania. No government contract regulations or clauses shall apply to the goods or services, this agreement, or act to bind Seller unless specifically agreed to by Seller in writing.

**NON-WAIVER BY SELLER:** Waiver by Seller of a breach of any of these terms and conditions shall not be construed as a waiver of any other breach.

**SEVERABILITY AND ENTIRE AGREEMENT:** If any provision of these terms and conditions is unenforceable, the remaining terms shall nonetheless continue in full force and effect. This writing, together with any other terms and conditions Seller specifically agrees to in writing, constitutes the entire terms and conditions of sale between Buyer and Seller and supercedes any and all prior discussions, and negotiations on its subject matter.





  
**DREXELBROOK**  
*An ISO 9001 Certified Company*

205 Keith Valley Road, Horsham, PA 19044  
U.S. and Canada: 1-800-553-9092  
24-Hour Service: 1-800-527-6297  
International: +1 215-674-1234  
Fax: +1 215-674-2731  
E-mail: [drexelbrook.info@ametek.com](mailto:drexelbrook.info@ametek.com)  
Website: [www.drexelbrook.com](http://www.drexelbrook.com)