

Installation & Maintenance Instructions

# Addendum to XDT User Manual

Detailing Standard Mission Critical Sample System  
with Seld Calibration or Self Validation capability



## Self-Calibrating Procedure

Background: It has been observed that when water vapor measurements are performed in the field, all measurement technologies are prone to inaccuracies due to contamination, temperature, pressure, aging, and some other parameters. Thus, providing a cost effective traceable means of measuring the content of water vapor is a non-trivial task. Xentaur has taken advantage of the quasi-linear characteristics of its Hyper Thin Film (HTF™) Aluminum Oxide ( $\text{Al}_2\text{O}_3$ ) sensors, and borrowed a self-calibrating approach used by many other types of analyzers (e.g. gas chromatographs), which periodically expose the sensor to a traceable certified gas and calibrate the sensor.

Overview: A specially configured sample system has been designed capable of introducing a calibration gas into the measuring sample cell. This system utilizes a pneumatic or electric motor actuated switchover valve, whereby the XDT software program can switch the sample stream to a calibration gas.

The XDT software program is capable of initiating the Self-Calibration procedure:

- a. by a front panel user selected menu
- b. by a user selected scheduled timer (battery backed) programmable: 0-1999 hrs
- c. by a (specially ordered option) remote activated 12 to 24VDC signal or contact closure.

Once the procedure is initiated the XDT "freezes" its Alarm relays, the user may choose whether the 4/20 mA analog output should be "frozen" or left to follow the actual measurement. Then the XDT actuates the switchover valve, and performs a 15-minute system stabilization timeout. Then, the XDT begins to test the measurement for stability, if the dewpoint changes less than  $0.6^\circ\text{C}$  in 3 minutes the measurement is assumed to be stable; this test is declared a failure if stability cannot be achieved within 30 minutes.

When there is a stable measurement, the XDT calibrates the sensor, using the preprogrammed dewpoint content of the calibration gas bottle. The Self-Calibration procedure is brought to a conclusion by deactivating the switchover valve and initiating a final stabilization test. When the measurement is stable the Alarms as well as the 4/20 mA analog output are "unfrozen", and the XDT returns to normal operation.

During the whole process, a contact closure can be optionally provided indicating that the XDT is in Self-Calibration Mode.

## Instructions:

- Make sure that your sample system is properly connected according to the sample system instructions.
- Make sure the instrument is unlocked (see Setup State Flow Diagram)
- Choose the Analog Output behavior during Self-Calibration
  - $Tr$  = track the measurement of the cal gas (see Setup State Flow Diagram)
  - $Fr$  = freeze last value measured before switching to cal gas

*For the steps outlined below refer to the un-shaded area of the User Flow Diagram.*

- Press the MODE button a few times until the display shows CAL.
  - Press the DOWN button to select the Self-Calibration mode. The display will show SLF/CAL
  - Press the UP button to confirm entry into the Self-Calibration mode. The display will show the calibration gas dewpoint that has been previously programmed into the instrument (*factory default*  $-40^{\circ}\text{C}$ ), the SET and DEWPOINT legends will also appear. Use the UP and DOWN buttons to modify this dewpoint to match the dewpoint that corresponds to the water content of your calibration gas. You may need the Xentaur moisture calculator to convert ppmV values marked on the bottle to dewpoint values to enter in the XDT.
  - Press the MODE button, the display will alternately show 720 / Hrs / Intvl, indicating that the wakeups are scheduled at '720 hours interval' (720 hrs=30 days). Use the UP and DOWN buttons to change the interval time to whatever is determined to be most effective for your application, consult with your representative if you are in doubt. An interval of 0 Hrs (*factory default*), disables any further scheduled unattended Self-Calibration sequences.
  - Pressing the Pressure Correct button will cause the instrument to momentarily display 150 / Hrs / LEFt, indicating that there are 150 hours left until the next scheduled Self-Calibration is performed. This is a useful indication in cases where it is not known when the next Self-Calibration will be performed.
  - Press the MODE button, the display will show BEG/5.C., prompting to begin the Self-Calibration procedure.
    - If the MODE or DOWN buttons are pressed, the Self-Calibration procedure will be canceled and instrument will go to the Serial Number mode. All setup will still be in effect, i.e. newly entered calibration gas dewpoint, the scheduled interval time etc. will still be used by the system.
  - Press the UP button to initiate the Self-Calibration. The display will show CONF/5.C?, prompting for a confirmation that the Self-Calibration should be performed.
  - If the DOWN or Pressure Correct buttons are pressed the Self-Calibration will be aborted, however everything set until now will remain in effect.
  - Press the UP button to confirm the Self-Calibration,  
*(this is also the entry place into the procedure when the scheduled time elapses or the remote 12-24VDC signal is activated) – refer to attached XDT Sensor Self-Calibration Procedure Flowchart as a guide to the steps performed by the analyzer.*
- The display will show SLF/CAL/-9 1.5 indicating that Self-Calibration has started

and the sensor is measuring a dewpoint of  $-91.5^{\circ}\text{C}$ , At this time the instrument will "freeze" the alarm relays and if necessary the analog output so that they are not influenced by the calibration gas, and will energize the optional Self-Calibration Procedure indicating relay. Then the instrument will activate the switchover valve and thus introduce the calibration gas to the sensor.

- At this point, a mandatory 15-minute timeout will be introduced to allow the sample system and sensor to achieve equilibrium.
- After the 15 minutes expire, the program will attempt to determine if the measurement is stable. The display will show  $5.7/56/-91.5$ . Stability is assumed if the measured dewpoint changes less than  $0.6^{\circ}\text{C}$  for a period of 3 minutes. If stability cannot be achieved in 30 minutes, then the Self-Calibration is aborted, and rescheduled.
- When there is a stable measurement, the XDT calibrates the sensor, using the preprogrammed dewpoint content of the calibration gas bottle. The Self-Calibration procedure is brought to a conclusion by deactivating the switchover valve and initiating a final stabilization test.
- During the final stabilization period the display shows the dewpoint being measured while alternately flashing  $5.7/Fl/-91.5$ . As in a previous step, the  $0.6^{\circ}\text{C}$  for 3 minutes criteria is used for stability.
- When the measurement is stable the Alarms as well as the 4/20 mA analog output are "unfrozen", the optional Self-Calibration Procedure indicating relay is de-energized.
- And the XDT returns to normal operation.

**MANUAL AND SCHEDULED SELF CALIBRATION USER INTERFACE** ☆ (the star indicates the entry point)  
 the original XDT user interface (see manual) is shaded in gray.

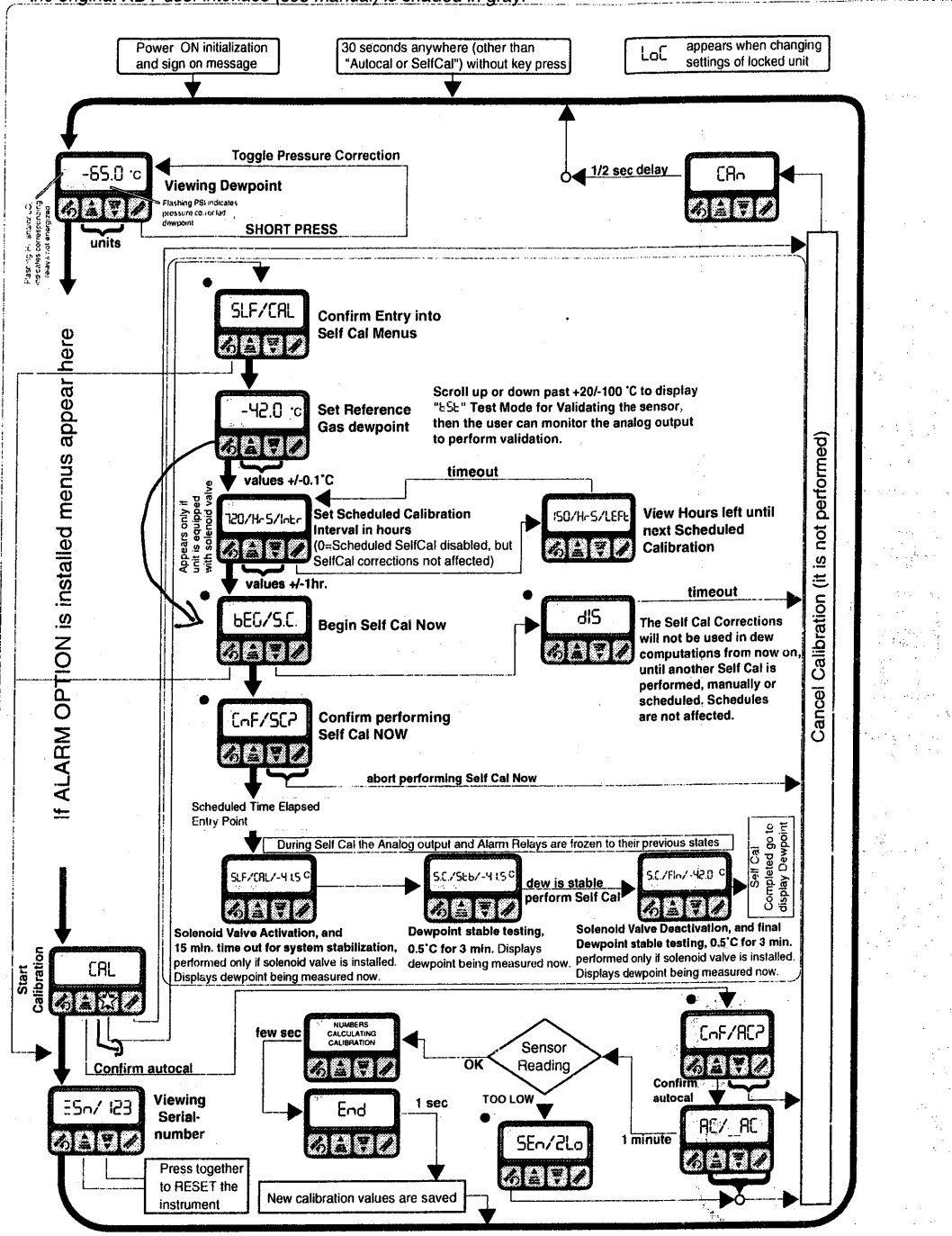

**Legend:** / separates alternately displayed messages  
 • denotes beeping  
 Buttons without designator or arrow leading out, perform no function

*XDT Setup State User Interface, updated with Analog Output behavior menu*

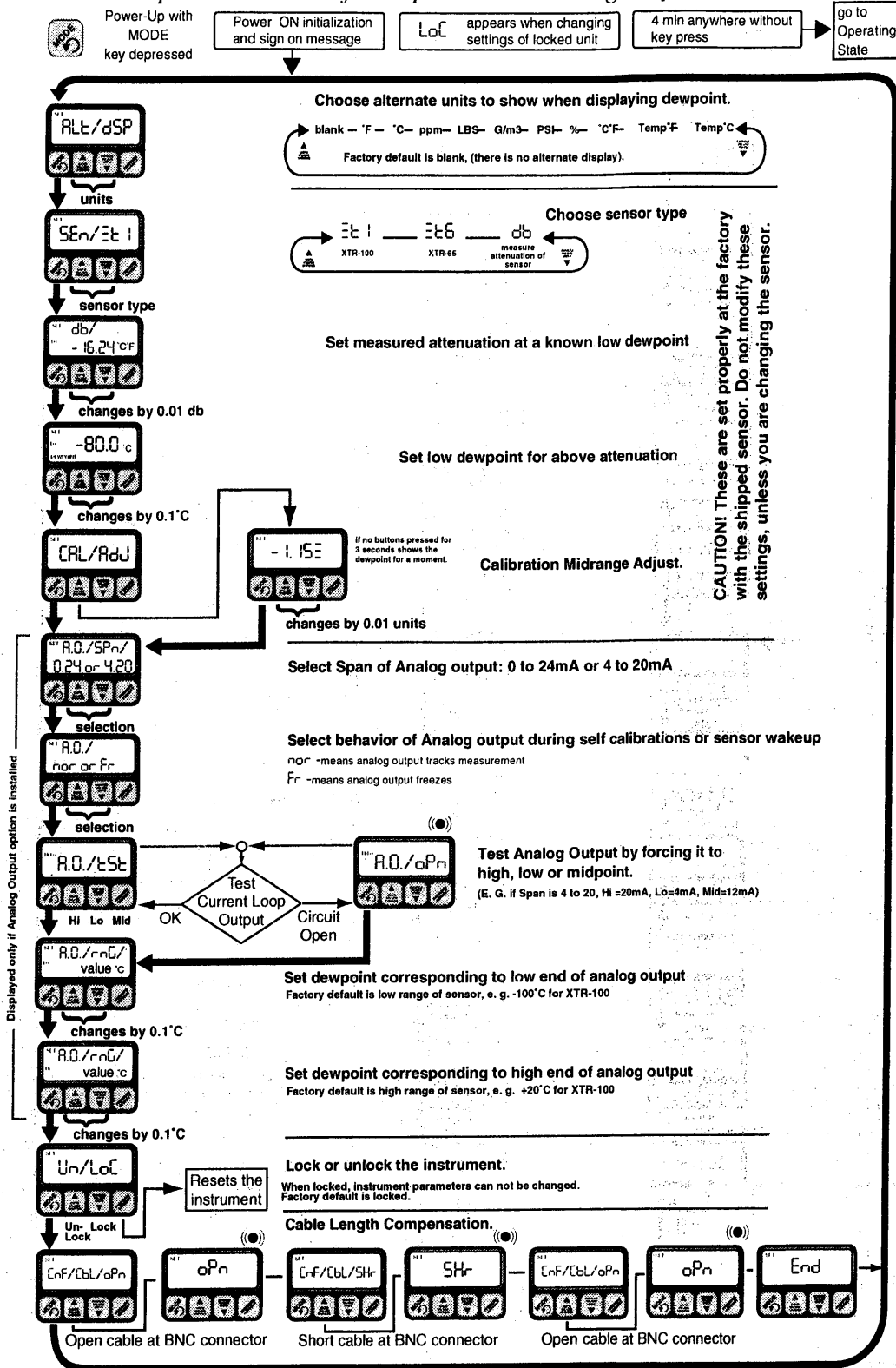

**Legend:** A slash '/' in the display area, is used to depict two alternately shown (flashing back and forth) messages.  
 (●) denotes beeping. Buttons without designator or arrow leading out, perform no function

# XDT Sensor Self-Calibration Self-Validation Procedure Flowchart

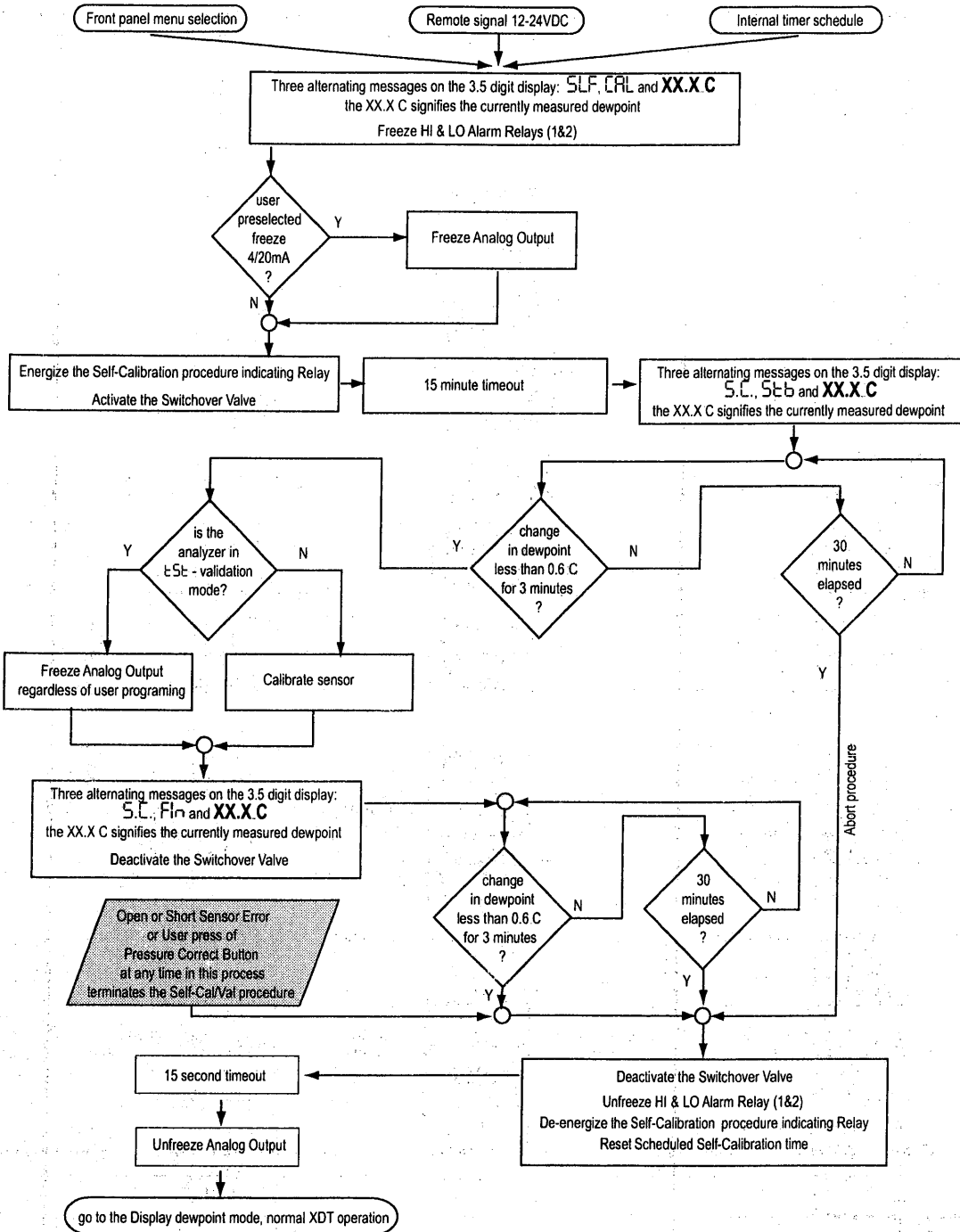

Self-Validation Initiating Event: External Sig., Timer or User button press

Active / Not-Active

Self-Validation procedure indicating Relay Contacts: Open / Closed

Process Gas Validation Gas Selection Valve: Validation Port / Process Port

Analog Output 4/20mA: high current / low current

Measurement performed by analyzer: high dewpoint / low dewpoint

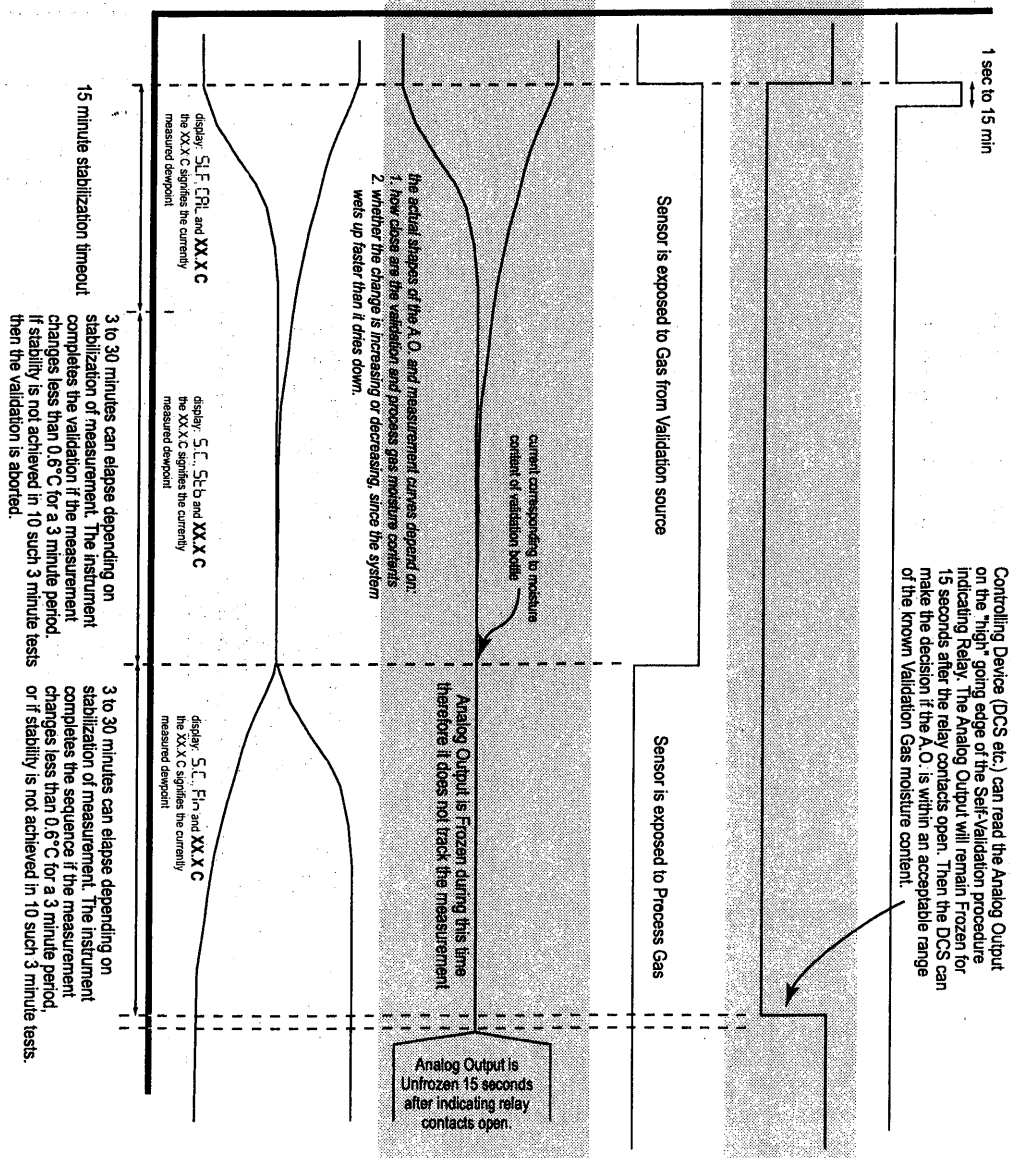

Timing Diagram for Xentaur Dewpoint Transmitter (XDT) Self-Validating Procedure.



# ANALYZER

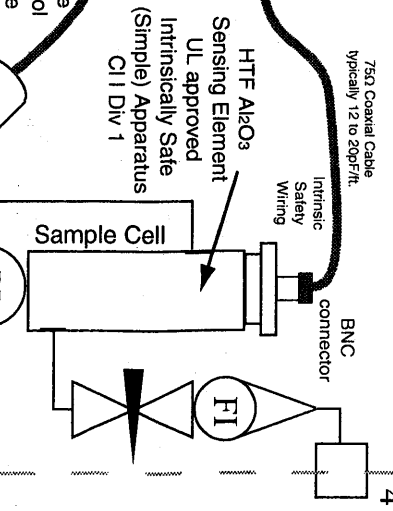
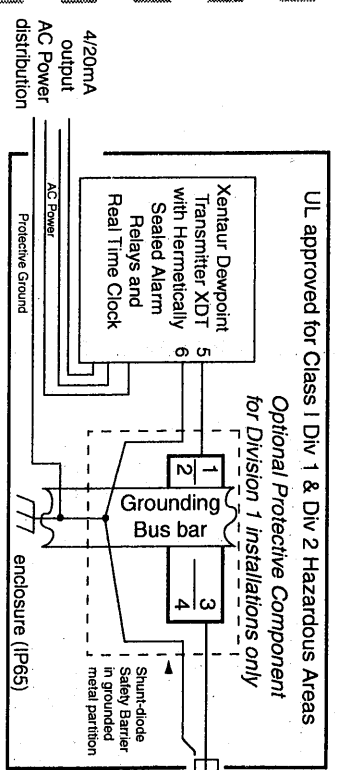

## Mission Critical Sample System

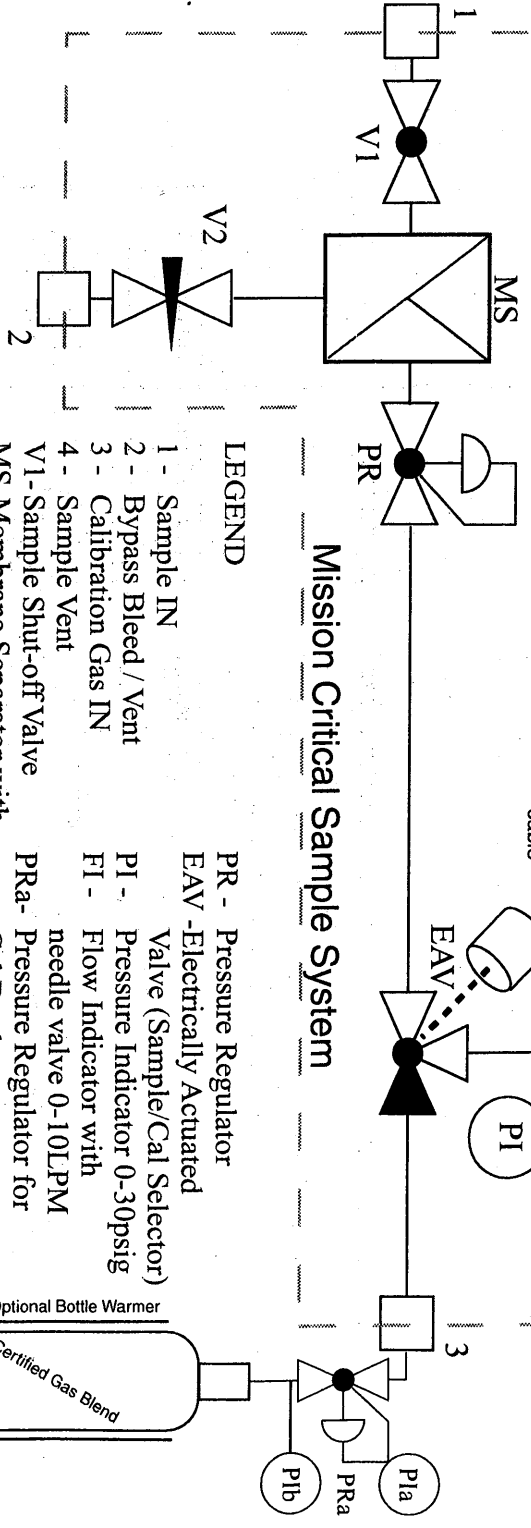

### LEGEND

- 1 - Sample IN
- 2 - Bypass Bleed / Vent
- 3 - Calibration Gas IN
- 4 - Sample Vent
- V1 - Sample Shut-off Valve
- MS - Membrane Separator with liquid flow blocking
- V2 - Bypass bleed/vent Valve
- PR - Pressure Regulator
- EAV - Electrically Actuated Valve (Sample/Cal Selector)
- PI - Pressure Indicator 0-30psig
- FI - Flow Indicator with needle valve 0-10LPM
- PRA - Pressure Regulator for Cal Bottle
- P1a&b - Pressure Indicators on Cal Bottle Regulator

# HAZARDOUS AREA

IS Class I, Division 2, Group A,B,C and D;  
 Class II Group E,F and G, T6 at 50°C and  
 EEx n II A,B,C T6

Revisions  
 Rev Description Date Approved

## Intrinsically Safe (Simple) Apparatus

Xentaur XTR-series  
 Dewpoint  
 Sensor Element

Female BNC Connector  
 on Sensor Fitting, Cable  
 must have a Male BNC  
 Connector. Polarity  
 back to Transmitter  
 must be observed.

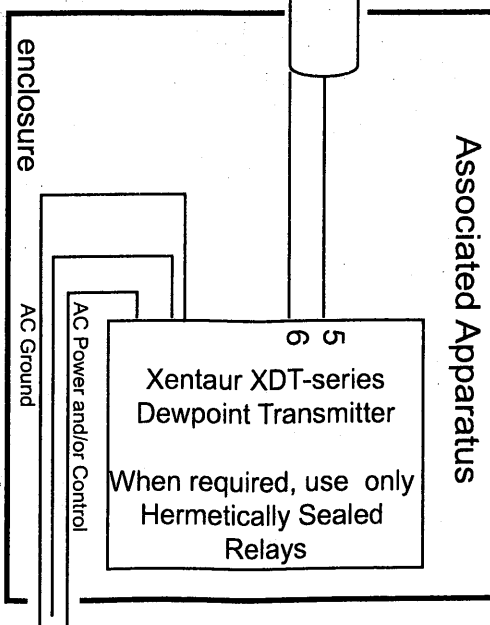
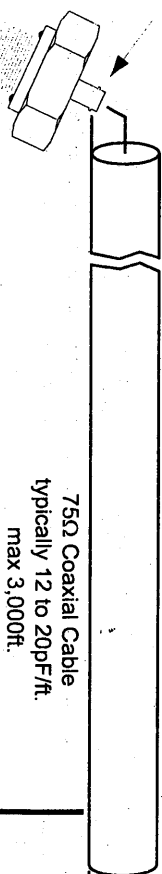

- Notes:
- A. Hazardous (Classified) Location Use: IS Class I Division 2 Groups A,B,C & D; Class II Group E,F and G, T6 at 50°C and EEx n II A,B,C T6
  - B. Installation must be in accordance with the ANSI/ISA RP12.6 "Installation of Intrinsically Safe Systems for Hazardous (Classified) Locations" and the National Electrical Code® (ANSI/NFPA 70, Articles 501-4(b) and 504).
  - C. The dewpoint transmitter must not be powered by equipment which contains a source of potential with respect to earth ground exceeding 250VRMS or 250VDC.
  - D. Evaluated under UL file no. E204260. No revisions to drawing without prior approval.

<p><b>TOLERANCES:</b>                  (unless otherwise stated)                  Decimal X = ± .030                  XX = ± .010                  XXX = ± .005                  Angular ± 1 deg.                  Do Not Scale Drawing.</p>		<p><b>XENTAUR Corporation</b>                  3661 HORSEBLOCK RD. MEDFORD, NY 11763</p> <p>Control Drawing for Approved Installation                  in Hazardous (Classified) Locations,                  of Xentaur XTR-series Dewpoint Sensor,                  connected to Associated Apparatus</p>	
Material & Finish: (see Notes)	SIZE A	Dwg. No. XDT.00 D.6004	Rev 0
Drawn: B.B.	Scale: N/A	Date: 11/3/99	Sheet 1 of 1

# HAZARDOUS AREA

IS Class I, Division 2, Group A,B,C and D;  
 Class II Group E, F and G; T6 at 50°C and  
 EEx n II A,B,C T6

Revisions	Rev	Description	Date	Approved

Female BNC Connector on Sensor Fitting, Cable must have a Male BNC Connector. Polarity back to Transmitter must be observed.

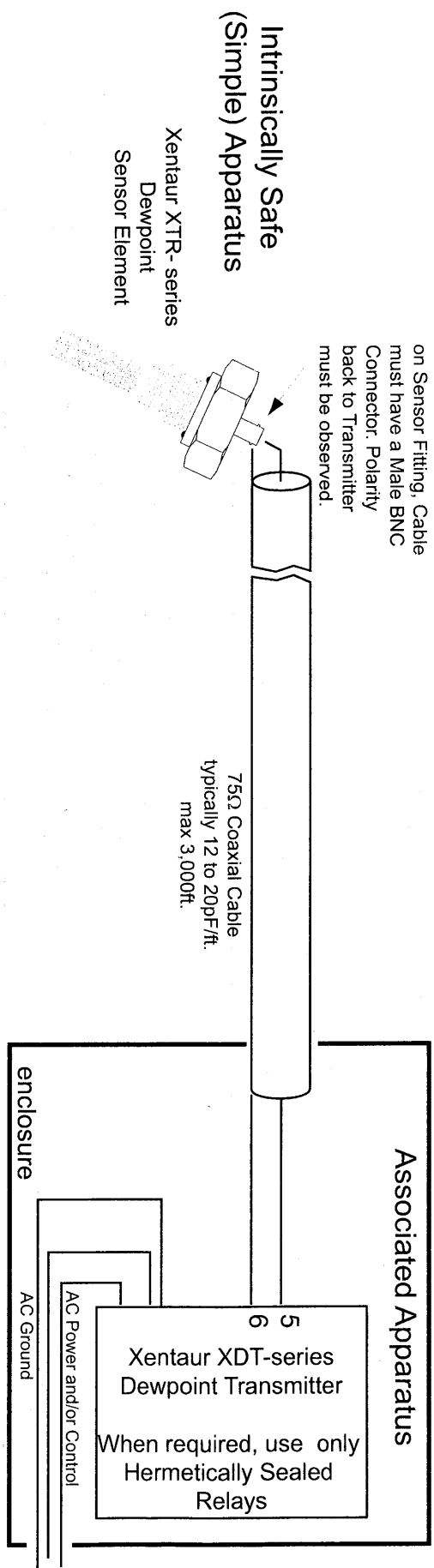

- Notes:
- A. Hazardous (Classified) Location Use: IS Class I Division 2 Groups A,B,C & D; Class II Group E,F and G; T6 at 50°C and EEx n II A,B,C T6
  - B. Installation must be in accordance with the ANSI/ISA RP12.6 "Installation of Intrinsically Safe Systems for Hazardous (Classified) Locations" and the National Electrical Code® (ANSI/NFPA 70, Articles 501-4(b) and 504).
  - C. The dewpoint transmitter must not be powered by equipment which contains a source of potential with respect to earth ground exceeding 250V/RMS or 250VDC.
  - D. Evaluated under UL file no. E204260. No revisions to drawing without prior approval.

<p><b>TOLERANCES:</b>                  (unless otherwise stated)                  Decimal X = ± .030                  XX = ± .010                  XXX = ± .005                  Angular ± 1 deg.                  Do Not Scale Drawing.</p>		<p><b>XENTAUR Corporation</b>                  3661 HORSEBLOCK RD. MEDFORD, NY 11763</p>	
<p>Control Drawing for Approved Installation in Hazardous (Classified) Locations, of Xentaur XTR-series Dewpoint Sensor, connected to Associated Apparatus</p>		<p>Material &amp; Finish: (see Notes)</p>	<p>SIZE A</p>
<p>Drawn: B.B.</p>	<p>Scale: N/A</p>	<p>Dwg. No. XDT.00.D.6004</p>	<p>Date: 11/3/99</p>
<p>Sheet 1 of 1</p>		<p>Rev 0</p>	<p> </p>

Temperature sensor thermally connected into copper bar, which protrudes through electronics box wall, to measure the temperature in the sample system enclosure

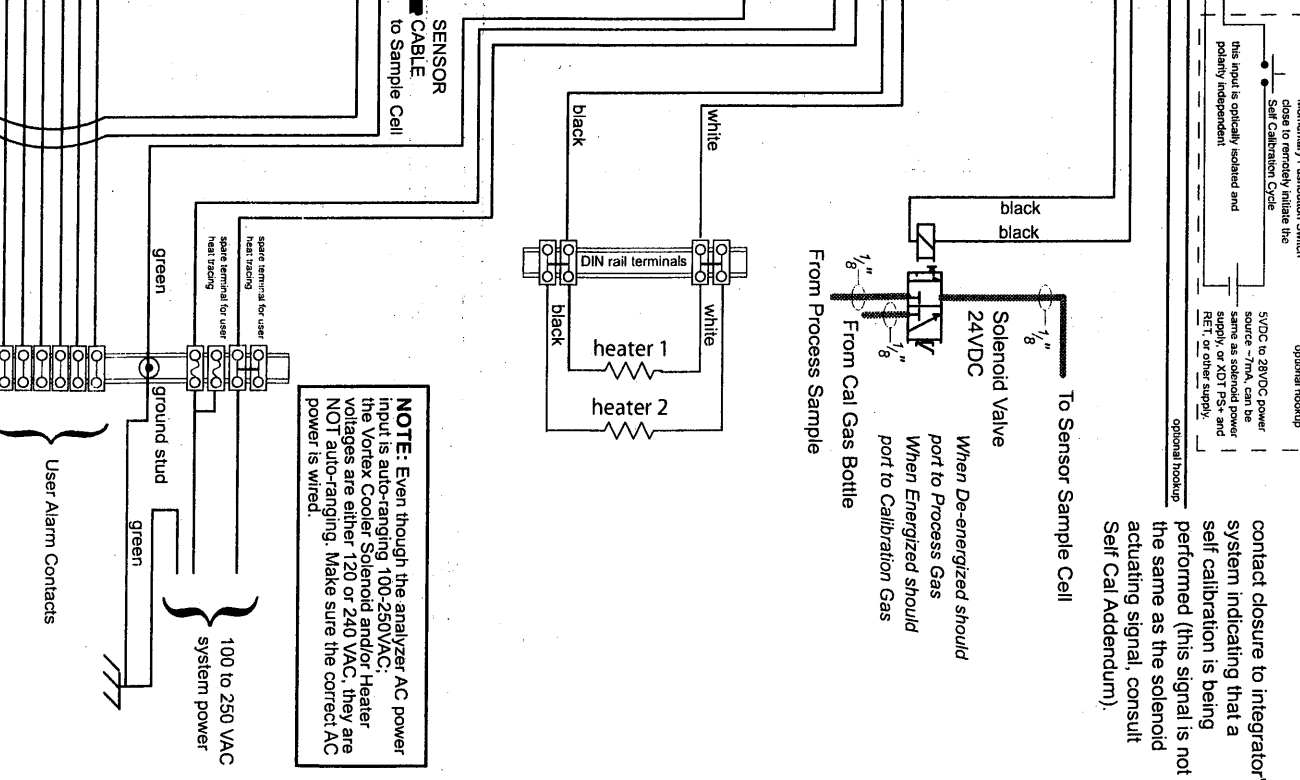
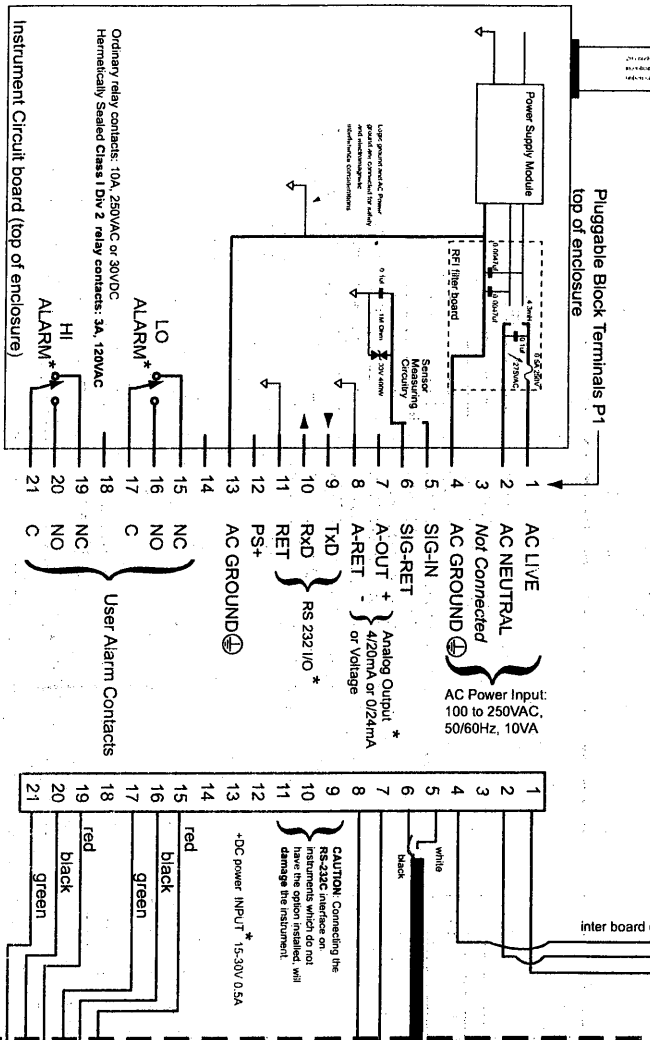
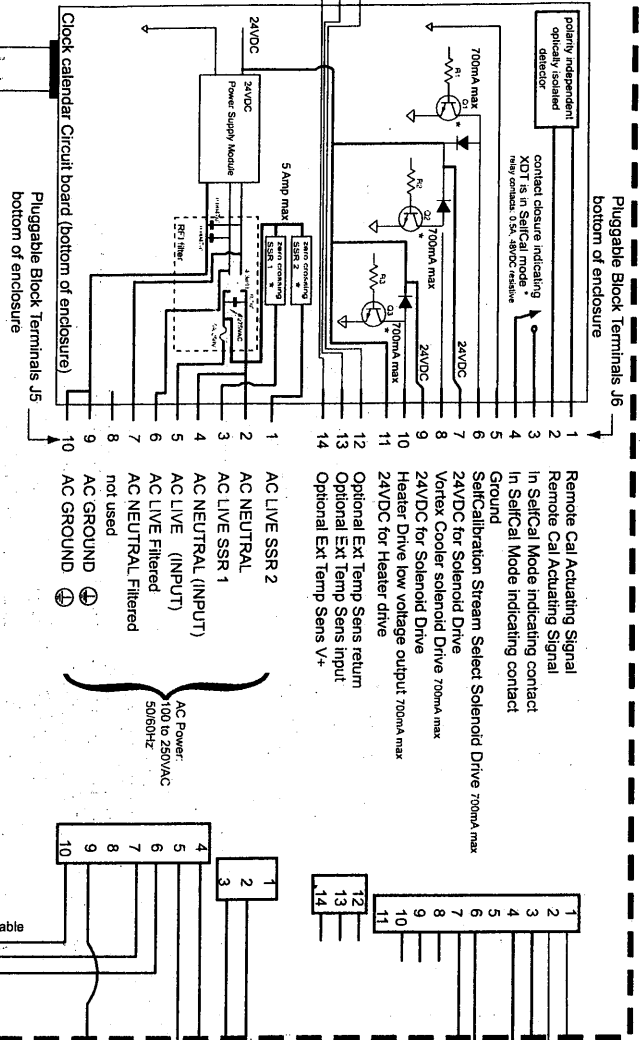

Xentaur Class 1 Div 2 Mission Critical System Wiring Diagram

contact closure to integrator's system indicating that a self calibration is being performed (this signal is not the same as the solenoid actuating signal, consult Self Cal Addendum).

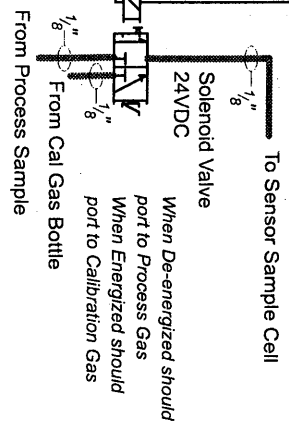

**NOTE:** Even though the analyzer AC power input is auto-ranging 100-250VAC, the Vortex Cooler Solenoid and/or Heater voltages are either 120 or 240 VAC, they are NOT auto-ranging. Make sure the correct AC power is wired.

Note: \* Options will function only if they are installed

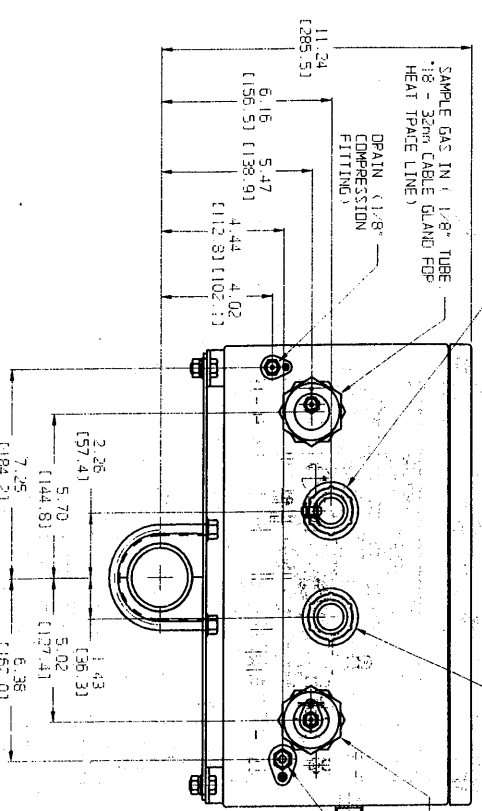
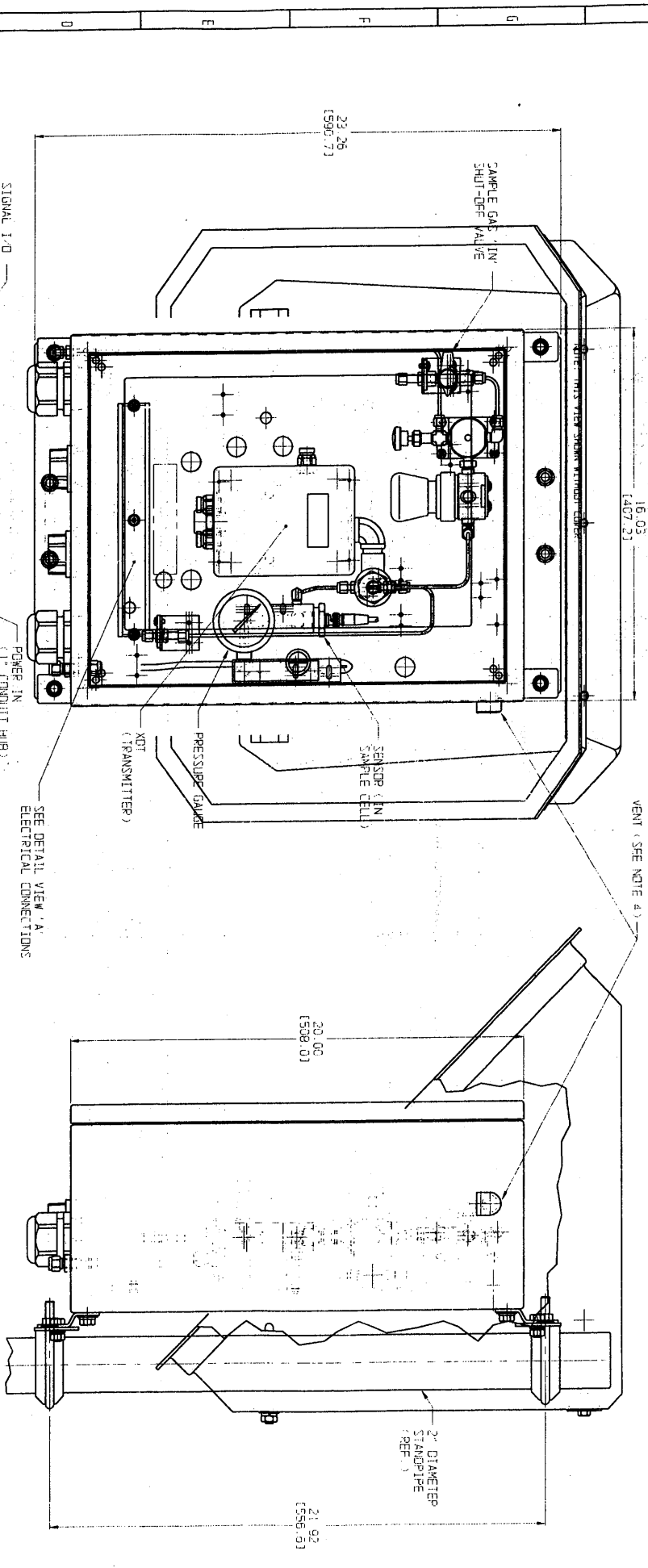

DETAIL VIEW 'A' - ELECTRICAL CONNECTIONS (SCALE 2X)

1	ANALOG OUTPUT	4-20 mA
2	ANALOG OUTPUT	1-5V DC
3	AC POWER	100-250 VAC (L)
4	AC POWER	100-250 VAC (L) ANALYZER
5	AC POWER	(N)
6	AC POWER	(N)
7	HEATER INTERLOCK INTERCONNECT	

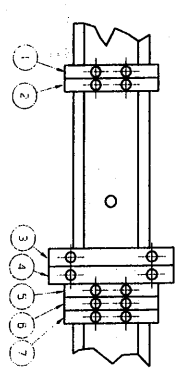

NOTES:  
 1) THE INSTALLATION DIAGRAM IS SHOWN IN INCH (U.S.) AND METRIC.  
 2) ALL DIMENSIONS UNLESS OTHERWISE SPECIFIED ARE IN INCHES.  
 3) THE OPERATOR MUST WEAR SAFETY GLASSES AND PROTECTIVE GLOVES.  
 4) THE OPERATOR MUST WEAR SAFETY GLASSES AND PROTECTIVE GLOVES.  
 5) THE OPERATOR MUST WEAR SAFETY GLASSES AND PROTECTIVE GLOVES.  
 6) THE OPERATOR MUST WEAR SAFETY GLASSES AND PROTECTIVE GLOVES.  
 7) THE OPERATOR MUST WEAR SAFETY GLASSES AND PROTECTIVE GLOVES.

**Verivair Corporation**  
 INSTALLATION DIAGRAM  
 SELF-CAL. CL. 1 DIV. 2  
 NATURAL GAS SAMPLING SYSTEM

