

Mission Critical Process Moisture Analyzer MODEL ESS-SCVP

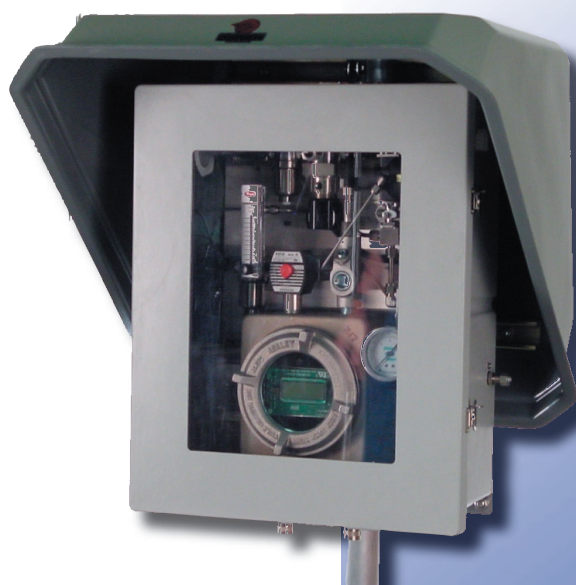

Class1 Div1 Grps ABCD, T4



Manufactured with pride
in the USA

Taking advantage of the uniquely strong and quasi-linear response characteristics of its HTF™ aluminum oxide moisture sensors, Xentaur has developed a cost effective solution for demanding and mission critical moisture monitoring applications.

The system has an integrated, fully automatic self-calibration procedure, in which the sensor is periodically exposed to a NIST certified calibration gas and recalibrated. Thus, there can be high NIST traceable confidence in the measurement and sensors do not need to be returned to the factory for calibration.

This system has proven to produce consistently accurate monitoring results in natural gas and hydrocarbon processing applications, where conventional analyzers have failed.

Advantages:

- High confidence in measurement
- Automatic Field-Calibration/Validation
- NIST Traceability
- Long Sensor Life
- Low Maintenance
- Low Installation Cost
- Never Return Sensors To the Factory

Applications:

- Natural Gas
- Hydrocarbon Processing
- Catalyst Protection
- Heat Treating
- Industrial Gases
- Dryer Control

Reading Office

Cutbush Park, Danehill, Lower Earley,
Reading, Berkshire. RG6 4UT. UK.
Tel: +44 (0)118 9311188
Email: info@able.co.uk

Aberdeen Office

Unit 6 Airside Business Park, Kirkhill Industrial Estate,
Dyce, Aberdeen. AB21 0GT. UK.
Tel: +44 (0)1224 725999
Email: ab@able.co.uk

Internet: www.able.co.uk
e-procurement: www.247able.com
Registered in England No: 01851002
VAT No: GB 417 2481 61



Mission-Critical Moisture Applications

In many applications, where control of moisture concentration has mission-critical character, industry has struggled with finding a stable, reliable and cost-effective measurement solution. Conventional sensors drift, vary with temperature or fall asleep even when measuring clean, inert gases, but when measuring in the presence of contaminants or corrosive constituents, most measurements have failed completely or sensor life is prohibitively short.

Consequently, moisture measurements are used in most cases to provide a general indication only, but not for actual process control and if used for alarming, large safety margins are applied. Thus, large potential savings that could result from true process optimization based on a reliable moisture measurement, had to be foregone.

HTF™ moisture sensors have proven already to provide stable and reliable measurements in many applications where other technologies have failed. Now, with the Moisture Analyzer Model ESS-SCVP, Xentaur is offering a tool for true process control with integrated field calibration and validation capabilities.

Sensor Calibration Using a Traceable Standard

Borrowing from a calibration procedure that is standard to many other process measurement technolo-

gies, Xentaur has developed a self-calibrating moisture system that periodically exposes the sensor to a NIST certified calibrating gas and automatically adjusts for observed deviations.

To perform the calibration procedure, a valve is included in the sample system, such that under the instrument's control, the sensor can be switched from the process gas to a NIST traceable Nitrogen/Water blend bottle. The known water content of the bottle is pre-entered into the instrument's memory together with a time schedule of verification/recalibration. The unattended instrument follows the schedule and performs the pre-programmed task of recalibrating. Thus the measurement near the water content of the bottle is essential with NIST traceable accuracy even if the contaminants in the process gas have caused the sensing element to drift. As the measurements get further and further from the calibration point, the accuracy diminishes slightly but, because of Xentaur's high capacitance, the measurement can be easily kept within the specified tolerance of the instrument.

This method is particularly attractive for uses where there is an accepted alarm point. E.g. for Natural Gas - seven (7) pound of water per million standard cubic feet (lbsH₂O/mmscf) - the calibration bottle can be ordered to contain 143 parts per million by volume (ppmV) of water which corresponds to 7 lbsH₂O/

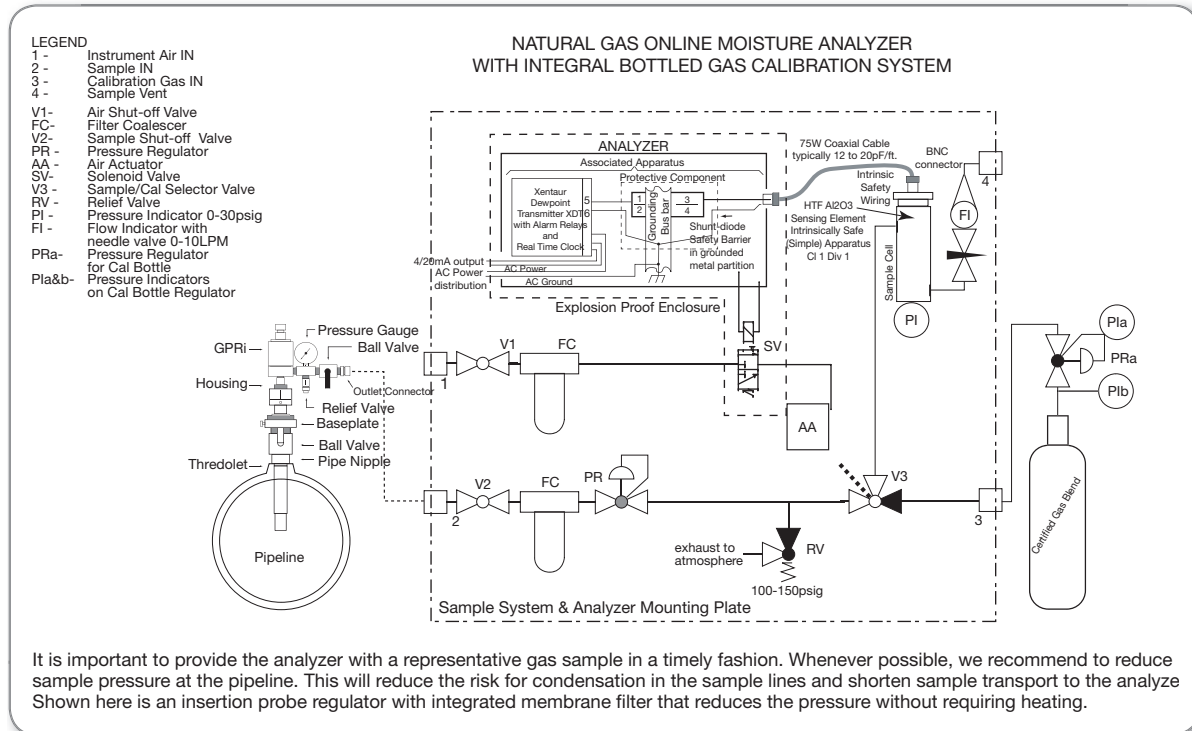

It is important to provide the analyzer with a representative gas sample in a timely fashion. Whenever possible, we recommend to reduce sample pressure at the pipeline. This will reduce the risk for condensation in the sample lines and shorten sample transport to the analyzer. Shown here is an insertion probe regulator with integrated membrane filter that reduces the pressure without requiring heating.

Reading Office

Cutbush Park, Danehill, Lower Earley,
Reading, Berkshire. RG6 4UT. UK.
Tel: +44 (0)118 9311188
Email: info@able.co.uk

Aberdeen Office

Unit 6 Airside Business Park, Kirkhill Industrial Estate,
Dyce, Aberdeen. AB21 0GT. UK.
Tel: +44 (0)1224 725999
Email: ab@able.co.uk

Internet: www.able.co.uk
e-procurement: www.247able.com
Registered in England No: 01851002
VAT No: GB 417 2481 61



mmscf. When an alarm is generated, one can have an extremely high confidence in the measurement near that point, and suspicions can quickly be settled with a verification/recalibration against the traceable bottled standard.

HTF™ Technology

The success of this approach in moisture measurement is centered on the high sensitivity HTF™ sensor, which has set new standards for moisture measurement. HTF™ sensors provide a very large and quasi-linear response to changes in moisture, which is an absolute requirement for adjusted moisture computations based on a single point calibration.

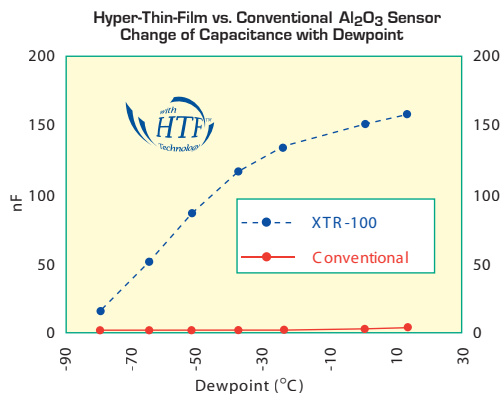

Additionally, HTF™ sensors can tolerate many contaminants commonly found in hydrocarbon processing and natural gas applications, such as H₂S, HCl, glycol, mercaptans, mercury, etc., and which cause other sensors to deteriorate quickly and fail. HTF™ sensors will provide many years of useful life, even in the presence of such contaminants.

Certified Calibration Gas



The calibration gas is supplied in specifically lined high pressure aluminum cylinders, which will discharge a constant water concentration from 1800 psi to 200 psi for nitrogen/water blends from 1 to 150 ppmv. Blending accuracy is ±10% and analytical accuracy is ±2%. The concentration is guaranteed for two years. One 152 cylinder will typically provide over 30 calibrations and last for over one year, based on two-week calibration intervals.

Field Proven in Challenging Applications
Model ESS-SCVP is field proven to work in

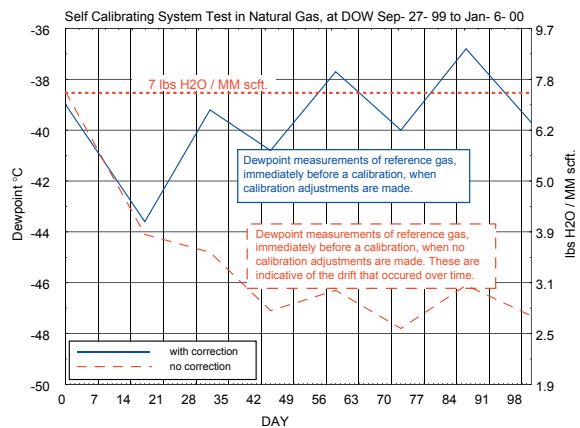

challenging applications. The graph above shows 90 days of dewpoint monitoring data with calibration adjustment in an applications where glycol carry-overs have prevented conventional systems from performing. After a settling period of two weeks, the system has reliably provided accurate results.

ESS-SCVP Div1

System with air actuated valve in stainless steel enclosure with window. Certified for Class1 Div1 Grps ABCD, T4 hazardous areas.



ESS-SCVP Div2

System with electrically actuated calibration valve in stainless steel enclosure, certified for Class1 Div2, Grps ABCD, T4 hazardous areas.



ESS-MCVP Div2

System with manually actuated calibration valve for 19" rack mounting, certified for Class1 Div2 Grps ABCD, T4 hazardous areas.



SPECIFICATIONS:

Sensor type High capacitance HTF™ Al₂O₃

Measurement Range:
 with XTR-100 -100°C(dp) to +20°C(dp) / 0.014 ppmv to 23700 ppmv / 0.0009 lbs to 1105 lbs.
 with XTR-65 -65°C(dp) to +20°C(dp) / 5.400 ppmv to 23700 ppmv / 0.2747 lbs to 1105 lbs

Capacitance 15nf to 200nf

Accuracy ±0.5°C(dp) at -100°C(t); ±1°C(dp) at -20°C(dp) / ±10% of reading in ppmv, lbs H₂O

Repeatability ±0.3°C(dp) at -100°C(t); ±0.6°C(dp) at -20°C(dp) / ±5% of reading in ppmv, lbs H₂O

Response Time For a step change from -40°C(dp) to -60°C(dp) / from 120 ppmv to 10 ppmv / from 4.6 lbs to 0.4 lbs:
 63% in 90 seconds, 90% in 450 seconds

Input Resolution 0.1°C(dp)

Indicators LCD with backlight, 3.5 digits and custom legends for units and mode, audio alert

Engineering units °C(dp), °F(dp), ppmv, g H₂O/m³, lbs H₂O/mm scf

Controls 4 push buttons, all settings stored in EPROM

Output options 4-20 mA or 0-24mA outputs, linear to selected engineering units, programmable span and range, 0.1°C(dp) resolution; RS-232 or RS-485, baud rate 9600

Isolation Sensor is isolated from the power supply, analog output and digital outputs

Alarm relays option: . . . Two programmable alarm relays with programmable variable hysteresis, rated at 10A@240V Failure indication programmable to trigger alarm relays.

Power requirements: . . . 100-250 VAC, 50 or 60 Hz, autoranging, 24 VDC optional

Electrical connections . . . pluggable screw terminal optional DIN rail

Gas connections 1/4" Swagelock, heat tracing entries optional

System enclosure Polycarbonate or stainless steel, W-17½" H-21½", D-8", optional thermostatically controlled heater, cooler, sunshade

Materials 316 or 316L stainless steel for all wetted parts

Transmitter enclosure:
 Class1 Div2 Polycarbonate, NEMA 4/4X , W-4.7", H-6.3", D-3.5" (can be mounted remotely with sensor output for Class1 Div1 output)
 Class1 Div1 Explosion proof box

Temperature range
 of electronics 14°F to 122°F (-10°C to +50°C); temperature coefficient of electronics: negligible
 of sensor -22°F to 104°F (-30°C to +50°C); temperature coefficient of sensor: negligible
 storage 40°F to 120°F (-40°C to +50°C)

Allowable pressure input
 at ambient 5-5000 psig

Outlet pressure Limited to 250 psi if there is an exhaust flow meter
 Up to maximum of inlet pressure possible (consult your sales representative)

Calibration:
 Factory NIST/NPL traceable multipoint table
 Field Fully automatic at user programmable intervals, using NIST certified gas standard

Calibration gas data:
 Gas Nitrogen/Water blend
 Water concentration . . 1 ppmv to 150 ppmv
 Blending accuracy . . ±10%
 Analytical accuracy . . ±2%
 Certification NIST

Cylinder 152 passivated aluminum cylinder at 1800 psi

Sample conditioning options:
 Pressure regulator . . . Maximum inlet pressure 3000 psi, outlet 1-30 psi adjustable (higher optional)
 Coalescing filter Borosilicate glass microfiber and fluorocarbon binder, efficiency rating of 99.99% against 0.1 micron particles and aerosols. Optional drain valve for fast loop and self-cleaning action
 Particulate filter Stainless steel mesh with 1 micron efficiency