



Installation & Maintenance Instructions

# VEGAPULS 67

4 ... 20 mA/HART - two-wire

Radar sensor for continuous level measurement of bulk solids

# VEGA

**Reading Office**

Cutbush Park, Danehill, Lower Earley,  
Reading, Berkshire. RG6 4UT. UK.  
Tel: +44 (0)118 9311188  
Email: info@able.co.uk

**Aberdeen Office**

Unit 6 Airside Business Park, Kirkhill Industrial Estate,  
Dyce, Aberdeen. AB21 0GT. UK.  
Tel: +44 (0)1224 725999  
Email: ab@able.co.uk

Internet: [www.able.co.uk](http://www.able.co.uk)  
e-procurement: [www.247able.com](http://www.247able.com)  
Registered in England No: 01851002  
VAT No: GB 417 2481 61



## Quick start

The quick start enables a quick setup with many applications. You can find further information in the respective chapters of the operating instructions manual.

### Mounting

1. Distance from the vessel wall > 200 mm

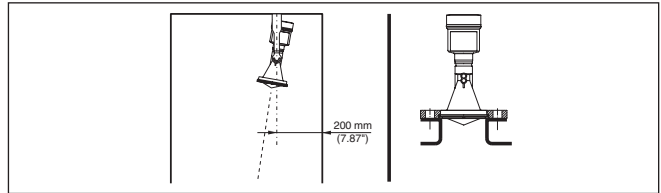

Fig. 1: Distance of the antenna to the vessel wall/socket configuration

2. Keep the socket short, round off the socket end

For further information see chapter "Mounting".

### Connect electrically

1. Make sure that the power supply corresponds to the specifications on the type label.
2. Connect the instrument according to the following illustration

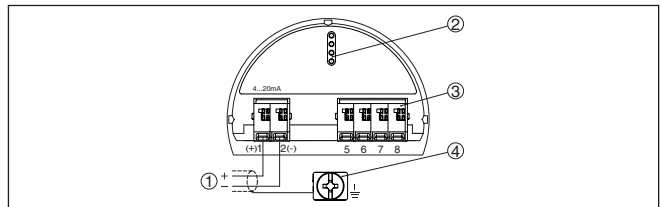

Fig. 2: Electronics and connection compartment, single chamber housing

- 1 Voltage supply, signal output
- 2 For indicating and adjustment module or interface adapter
- 3 For external indicating and adjustment unit
- 4 Ground terminal for connection of the cable screen

For further information see chapter "Connecting to power supply".

### Set parameters

1. Go via the indicating and adjustment module to the menu "Setup".

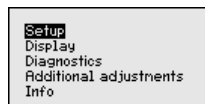

2. Select in the menu item "Medium" the medium of your application, for example "Gravel/Pebble".

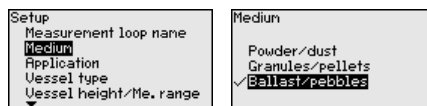

3. Select in the menu item "Application" the vessel, the application and the vessel form, for example, silo.

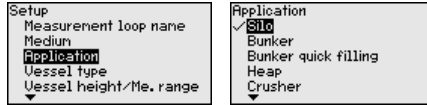

4. Carry out the adjustment in the menu items "Min. adjustment" and "Max. adjustment".

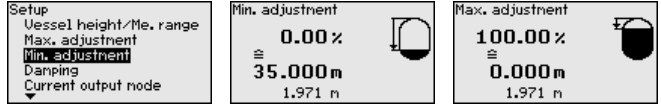

**Parameterization example** The radar sensor measures the distance from the sensor to the product surface. For indication of the real level, an allocation of the measured distance to the percentage height must be carried out.

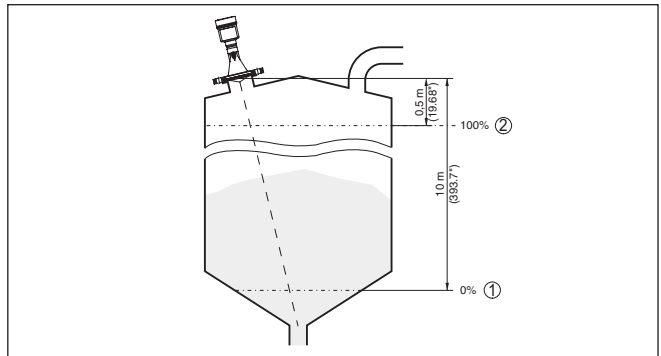

Fig. 3: Parameterization example

- 1 Min. level  $\hat{=}$  max. meas. distance
- 2 Max. level  $\hat{=}$  min. meas. distance

For this adjustment, the distance is entered with full and virtually empty vessel. If these values are not known, an adjustment with distances, for example, of 10 % and 90 % is also possible. Starting point for these distance specifications is always the seal surface of the thread or flange.

**Further steps**

1. In the menu "Additional settings", menu item "Damping" you have to adjust the requested damping of the output signal.
2. Select the output characteristics in the menu item "Current output".

The quick start is then finished. For further information see chapter "Parameter adjustment".

## Contents

<b>1 About this document</b>	
1.1 Function .....	6
1.2 Target group .....	6
1.3 Symbolism used .....	6
<b>2 For your safety</b>	
2.1 Authorised personnel .....	7
2.2 Appropriate use .....	7
2.3 Warning about incorrect use .....	7
2.4 General safety instructions .....	7
2.5 CE conformity .....	8
2.6 NAMUR recommendations .....	8
2.7 Radio license for Europe .....	8
2.8 Radio license for USA/Canada .....	8
2.9 Environmental instructions .....	9
<b>3 Product description</b>	
3.1 Configuration .....	10
3.2 Principle of operation .....	11
3.3 Packaging, transport and storage .....	11
3.4 Accessories and replacement parts .....	12
<b>4 Mounting</b>	
4.1 General instructions .....	14
4.2 Collar or adapter flange .....	14
4.3 Mounting strap .....	15
4.4 Instructions for installation .....	16
<b>5 Connecting to power supply</b>	
5.1 Preparing the connection .....	25
5.2 Connecting .....	26
5.3 Wiring plan, single chamber housing .....	27
5.4 Wiring plan, double chamber housing .....	28
5.5 Wiring plan, double chamber housing Ex d .....	29
5.6 Wiring plan - version IP 66/IP 68, 1 bar .....	30
5.7 Switch-on phase .....	30
<b>6 Set up with the indicating and adjustment module</b>	
6.1 Insert indicating and adjustment module .....	32
6.2 Adjustment system .....	33
6.3 Parameter adjustment .....	34
6.4 Saving the parameter adjustment data .....	47
<b>7 Setup with PACTware</b>	
7.1 Connect the PC .....	48
7.2 Parameter adjustment with PACTware .....	49
7.3 Saving the parameter adjustment data .....	50
<b>8 Set up with other systems</b>	
8.1 DD adjustment programs .....	51
8.2 Communicator 375, 475 .....	51
<b>9 Diagnosis, Asset Management and service</b>	

9.1	Maintenance .....	52
9.2	Measured value and event memory .....	52
9.3	Asset Management function.....	53
9.4	Rectify faults.....	56
9.5	Exchanging the electronics module.....	59
9.6	Software update .....	60
9.7	How to proceed in case of repair .....	60
<b>10</b>	<b>Dismounting</b>	
10.1	Dismounting steps.....	61
10.2	Disposal .....	61
<b>11</b>	<b>Supplement</b>	
11.1	Technical data .....	62
11.2	Dimensions .....	68



### Safety instructions for Ex areas

Please note the Ex-specific safety information for installation and operation in Ex areas. These safety instructions are part of the operating instructions manual and come with the Ex-approved instruments.

Editing status: 2012-09-27

# 1 About this document

## 1.1 Function

This operating instructions manual provides all the information you need for mounting, connection and setup as well as important instructions for maintenance and fault rectification. Please read this information before putting the instrument into operation and keep this manual accessible in the immediate vicinity of the device.

## 1.2 Target group

This operating instructions manual is directed to trained qualified personnel. The contents of this manual should be made available to these personnel and put into practice by them.

## 1.3 Symbolism used



### Information, tip, note

This symbol indicates helpful additional information.



**Caution:** If this warning is ignored, faults or malfunctions can result.

**Warning:** If this warning is ignored, injury to persons and/or serious damage to the instrument can result.

**Danger:** If this warning is ignored, serious injury to persons and/or destruction of the instrument can result.



### Ex applications

This symbol indicates special instructions for Ex applications.



### List

The dot set in front indicates a list with no implied sequence.



### Action

This arrow indicates a single action.



### Sequence

Numbers set in front indicate successive steps in a procedure.



### Battery disposal

This symbol indicates special information about the disposal of batteries and accumulators.

## 2 For your safety

### 2.1 Authorised personnel

All operations described in this operating instructions manual must be carried out only by trained specialist personnel authorised by the plant operator.

During work on and with the device the required personal protective equipment must always be worn.

### 2.2 Appropriate use

VEGAPULS 67 is a sensor for continuous level measurement.

You can find detailed information on the application range in chapter "*Product description*".

Operational reliability is ensured only if the instrument is properly used according to the specifications in the operating instructions manual as well as possible supplementary instructions.

### 2.3 Warning about incorrect use

Inappropriate or incorrect use of the instrument can give rise to application-specific hazards, e.g. vessel overflow or damage to system components through incorrect mounting or adjustment.

### 2.4 General safety instructions

This is a state-of-the-art instrument complying with all prevailing regulations and guidelines. The instrument must only be operated in a technically flawless and reliable condition. The operator is responsible for the trouble-free operation of the instrument.

During the entire duration of use, the user is obliged to determine the compliance of the necessary occupational safety measures with the current valid rules and regulations and also take note of new regulations.

The safety instructions in this operating instructions manual, the national installation standards as well as the valid safety regulations and accident prevention rules must be observed by the user.

For safety and warranty reasons, any invasive work on the device beyond that described in the operating instructions manual may be carried out only by personnel authorised by the manufacturer. Arbitrary conversions or modifications are explicitly forbidden.

The safety approval markings and safety tips on the device must also be observed.

Depending on the instrument version, the emitting frequencies are in the C or K band range. The low emitting frequencies are far below the internationally approved limit values. When used correctly, there is no danger to health.

## 2.5 CE conformity

The device fulfills the legal requirements of the applicable EC guidelines. By affixing the CE marking, we confirm successful testing of the product.

You can find the conformity certificate in the download section of our homepage.

### Only with Ex-d-ia version

The instrument is designed for use in an industrial environment. Nevertheless, electromagnetic interference from electrical conductors and radiated emissions must be taken into account, as is usual with a class A instrument according to EN 61326-1. If the instrument is used in a different environment, its electromagnetic compatibility with other devices must be ensured by suitable measures.

## 2.6 NAMUR recommendations

NAMUR is the automation technology user association in the process industry in Germany. The published NAMUR recommendations are accepted as the standard in field instrumentation.

The device fulfills the requirements of the following NAMUR recommendations:

- NE 21 – Electromagnetic compatibility of equipment
- NE 43 – Signal level for malfunction information from measuring transducers
- NE 53 – Compatibility of field devices and indicating/adjustment components
- NE 107 - Self-monitoring and diagnosis of field devices

For further information see [www.namur.de](http://www.namur.de).

## 2.7 Radio license for Europe

The instrument is approved according to EN 302372-1/2 (2006-04) for use in closed vessels.

## 2.8 Radio license for USA/Canada

The instrument is in conformity with part 15 of the FCC regulations. Take note of the following two regulations:

- The instrument must not cause any interfering emissions
- The device must be insensitive to interfering immissions, including those that may cause undesirable operating conditions

Modifications not expressly approved by the manufacturer will lead to expiry of the operating licence according to FCC/IC.

The instrument is in conformity with RSS-210 of the IC regulations.

The instrument may only be used in closed vessels made of metal, concrete, or fibre-reinforced plastic.



## 2.9 Environmental instructions

Protection of the environment is one of our most important duties. That is why we have introduced an environment management system with the goal of continuously improving company environmental protection. The environment management system is certified according to DIN EN ISO 14001.

Please help us fulfil this obligation by observing the environmental instructions in this manual:

- Chapter "*Packaging, transport and storage*"
- Chapter "*Disposal*"

## 3 Product description

### 3.1 Configuration

#### Type label

The type label contains the most important data for identification and use of the instrument:

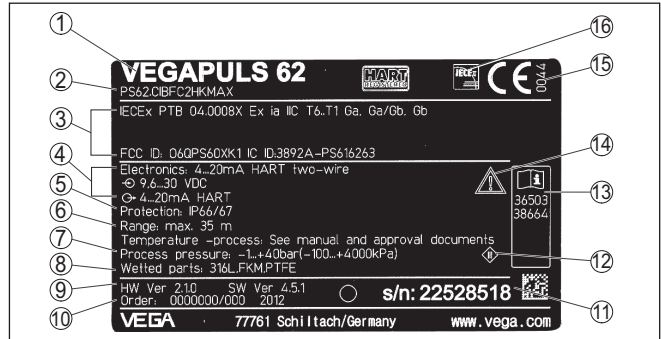

Fig. 4: Layout of the type label (example)

- 1 Instrument type
- 2 Product code
- 3 Approvals
- 4 Power supply and signal output, electronics
- 5 Protection rating
- 6 Measuring range
- 7 Process and ambient temperature, process pressure
- 8 Material, wetted parts
- 9 Hardware and software version
- 10 Order number
- 11 Serial number of the instrument
- 12 Symbol of the device protection class
- 13 ID numbers, instrument documentation
- 14 Note to observe the instrument documentation
- 15 Notified authority for CE marking
- 16 Approval directive

#### Serial number

With the serial number of the instrument on the type label you have access to the following data on our homepage:

- Article number of the instrument (HTML)
- Delivery date (HTML)
- Order-specific instrument features (HTML)
- Operating instructions at the time of shipment (PDF)
- Order-specific sensor data for an electronics exchange (XML)
- Test certificate "Measuring Accuracy" (PDF)

For this purpose, move to [www.vega.com](http://www.vega.com) and "VEGA Tools".

#### Scope of this operating instructions manual

This operating instructions manual applies to the following instrument versions:

- Hardware from 2.1.0
- Software from 4.5.1

<b>Scope of delivery</b>	<p>The scope of delivery encompasses:</p> <ul style="list-style-type: none"> <li>● Radar sensor</li> <li>● Documentation             <ul style="list-style-type: none"> <li>– this operating instructions manual</li> <li>– Test certificate measuring accuracy (optional)</li> <li>– Operating instructions manual "<i>Indicating and adjustment module</i>" (optional)</li> <li>– Supplementary instructions "<i>GSM/GPRS radio module</i>" (optional)</li> <li>– Supplementary instructions manual "<i>Heating for indicating and adjustment module</i>" (optional)</li> <li>– Supplementary instructions manual "<i>Plug connector for continuously measuring sensors</i>" (optional)</li> <li>– Ex-specific "<i>Safety instructions</i>" (with Ex versions)</li> <li>– if necessary, further certificates</li> </ul> </li> </ul>
--------------------------	---

### 3.2 Principle of operation

<b>Application area</b>	<p>The VEGAPULS 67 is a radar sensor for continuous level measurement of bulk solids under simple process conditions. It is suitable for smaller silos and vessels.</p> <p>The instrument is also suitable for applications in liquids.</p>
-------------------------	---

<b>Functional principle</b>	<p>The antenna of the radar sensor emits short radar pulses with a duration of approx. 1 ns. These pulses are reflected by the product and received by the antenna as echoes. The transit time of the radar pulses from emission to reception is proportional to the distance and hence to the level. The determined level is converted into an appropriate output signal and outputted as measured value.</p>
-----------------------------	--

### 3.3 Packaging, transport and storage

<b>Packaging</b>	<p>Your instrument was protected by packaging during transport. Its capacity to handle normal loads during transport is assured by a test according to DIN EN 24180.</p>
------------------	--

The packaging of standard instruments consists of environment-friendly, recyclable cardboard. For special versions, PE foam or PE foil is also used. Dispose of the packaging material via specialised recycling companies.

<b>Transport</b>	<p>Transport must be carried out under consideration of the notes on the transport packaging. Nonobservance of these instructions can cause damage to the device.</p>
------------------	---

<b>Transport inspection</b>	<p>The delivery must be checked for completeness and possible transit damage immediately at receipt. Ascertained transit damage or concealed defects must be appropriately dealt with.</p>
-----------------------------	--

<b>Storage</b>	<p>Up to the time of installation, the packages must be left closed and stored according to the orientation and storage markings on the outside.</p>
----------------	--

Unless otherwise indicated, the packages must be stored only under the following conditions:

- Not in the open
  - Dry and dust free
  - Not exposed to corrosive media
  - Protected against solar radiation
  - Avoiding mechanical shock and vibration
- Storage and transport temperature see chapter "*Supplement - Technical data - Ambient conditions*"
  - Relative humidity 20 ... 85 %

### Storage and transport temperature

### Indicating and adjustment module

## 3.4 Accessories and replacement parts

The indicating and adjustment module PLICSCOM is used for measured value indication, adjustment and diagnosis. It can be inserted into the sensor and removed at any time.

You can find further information in the operating instructions "*Indicating and adjustment module PLICSCOM*" (Document-ID 27835).

### Interface adapter

The interface adapter VEGACONNECT enables the connection of communication-capable instruments to the USB interface of a PC. For parameter adjustment of these instruments, an adjustment software such as PACTware with VEGA-DTM is required.

You can find further information in the operating instructions "*Interface adapter VEGACONNECT*" (Document-ID 32628).

### External indicating and adjustment unit

VEGADIS 61 is an external indicating and adjustment unit for sensors with single chamber housing and Ex-d double chamber housing.

It is suitable for measured value indication and adjustment of plics<sup>®</sup> sensors and is connected to the sensor with a four-wire standard cable up to 50 m long.

You can find further information in the operating instructions "*VEGADIS 61*" (Document-ID 27720).

### External indicating and adjustment unit with HART protocol

VEGADIS 62 is suitable for measured value indication and adjustment of sensors with HART protocol. It is looped into the 4 ... 20 mA/HART signal cable.

You can find further information in the operating instructions "*VEGADIS 62*" (Document-ID 36469).

### External radio unit

The PLICSMOBILE T61 is an external GSM/GPRS radio unit for transmission of measured values and for remote parameter adjustment of plics<sup>®</sup> sensors. The adjustment is carried out via PACTware/DTM by using the integrated USB connection.

You can find further information in the supplementary instructions "*PLICSMOBILE T61*" (Document-ID 36849).

### Protective cover

The protective cover protects the sensor housing against soiling and intense heat from solar radiation.

You will find additional information in the supplementary instructions manual "*Protective cover*" (Document-ID 34296).

**Electronics module**

The electronics module VEGAPULS series 60 is a replacement part for radar sensors of VEGAPULS series 60. There is a different version available for each type of signal output.

You can find further information in the operating instructions "*Electronics module VEGAPULS series 60*" (Document-ID 36801).

## 4 Mounting

### 4.1 General instructions

#### Screwing in

With instruments with threaded process fitting, suitable tools must be applied for tightening the hexagon.



#### Warning:

The housing must not be used to screw the instrument in! Applying tightening force can damage internal parts of the housing.

#### Moisture

Use the recommended cables (see chapter "*Connecting to power supply*") and tighten the cable gland.

You can give your instrument additional protection against moisture penetration by leading the connection cable downward in front of the cable entry. Rain and condensation water can thus drain off. This applies mainly to outdoor mounting as well as installation in areas where high humidity is expected (e.g. through cleaning processes) or on cooled or heated vessels.

#### Suitability for the process conditions

Make sure that all parts of the instrument exposed to the process, in particular the active measuring component, process seal and process fitting, are suitable for the existing process conditions. These include above all the process pressure, process temperature as well as the chemical properties of the medium.

You can find the specifications in chapter "*Technical data*" and on the type label.

### 4.2 Collar or adapter flange

For mounting the instrument on a socket, a combi compression flange for DN 80 (ASME 3" or JIS 80) is also available for retro fitting. Optionally, the instrument can be also equipped with an adapter flange from DN 100 (ASME 4" or JIS 100).

With the housing versions plastic, aluminium single chamber and stainless steel, the collar flange can be placed directly over the housing. With the aluminium double chamber housing, retroactive mounting in this way is not possible - the mounting type must be specified with the order.

You can find drawings of these mounting options in chapter "*Dimensions*".

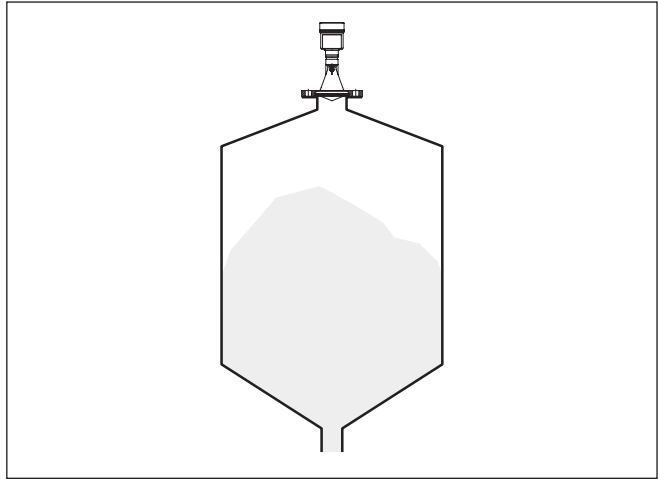

Fig. 5: Flange mounting of the radar sensor

### 4.3 Mounting strap

#### Mounting strap

The mounting strap enables simple mounting on the vessel wall or silo top. It is suitable for wall, ceiling or boom mounting. Especially in open vessels this is a very easy and effective way to align the sensor to the bulk solid surface.

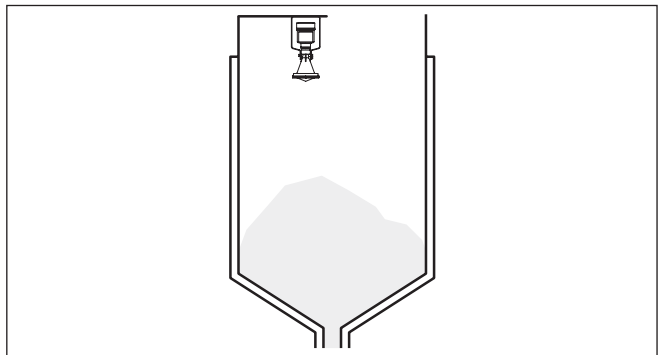

Fig. 6: Radar sensor with mounting strap

The strap is supplied unassembled and must be screwed to the sensor before setup with three hexagon screws M5 x 10 and spring washers. Max. torque, see chapter "Technical data". Required tools: Allen wrench size 4.

There are two ways to screw the strap onto the sensor. Depending on the selected version, the sensors can be swivelled in the strap as follows:

- Single chamber housing
  - Angle of inclination 180°, infinitely variable

- Angle of inclination in three steps 0°, 90° and 180°
- Double chamber housing
  - Angle of inclination 90°, infinitely variable
  - Angle of inclination in two steps 0° and 90°

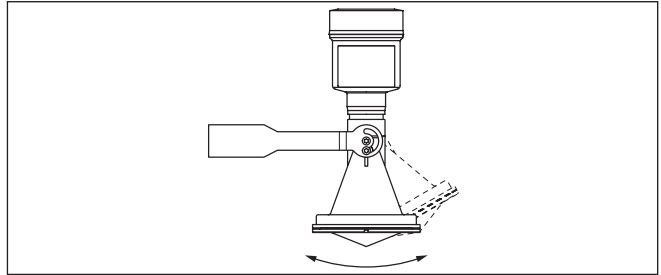

Fig. 7: Adjustment of the angle of inclination

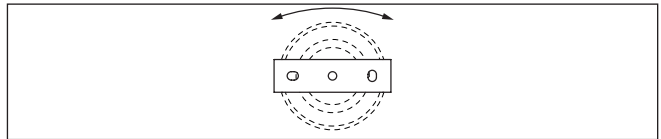

Fig. 8: Turning by fastening in the centre

#### 4.4 Instructions for installation

##### Tight installation of the plastic horn antenna

For tight installation of the version with plastic horn antenna with compression or adapter flange, the following conditions must be fulfilled:

1. Use suitable flat seal, e.g. of EPDM with Shore hardness 25 or 50
2. Make sure the number of flange screws corresponds to the number of flange holes
3. Tighten all screws with the torque stated in the technical data

##### Polarisation plane

The emitted radar impulses of the radar sensor are electromagnetic waves. The polarisation plane is the direction of the electrical wave component. By turning the instrument in the connection flange or mounting boss, the polarisation can be used to reduce the effects of false echoes.

The position of the polarisation level is marked by markings on the instrument.

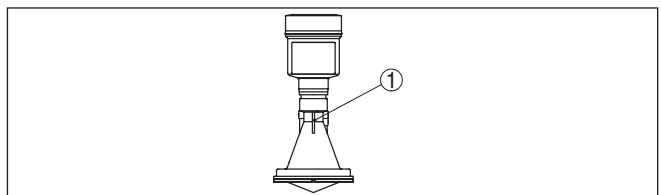

Fig. 9: Position of the polarisation level

1 Marking bar



**Installation position**

Mount the instrument at least 200 mm (7.874 in) away from the vessel wall.

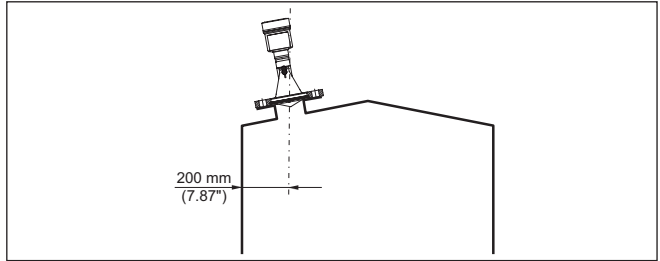

Fig. 10: Mounting of the radar sensor on the vessel top

If you cannot keep this distance you should carry out a false echo storage before setup. This applies mainly if buildup on the vessel wall is expected. In this case, we recommend repeating a false echo storage later with existing buildup.

**Inflowing medium**

**Filling from the top:** Mounting should not be too close to the inflowing material as the microwave signal will be interfered. The optimum mounting position is on the opposite of the filling. To avoid strong pollution, the distance to the filter or dust extraction must be as big as possible.

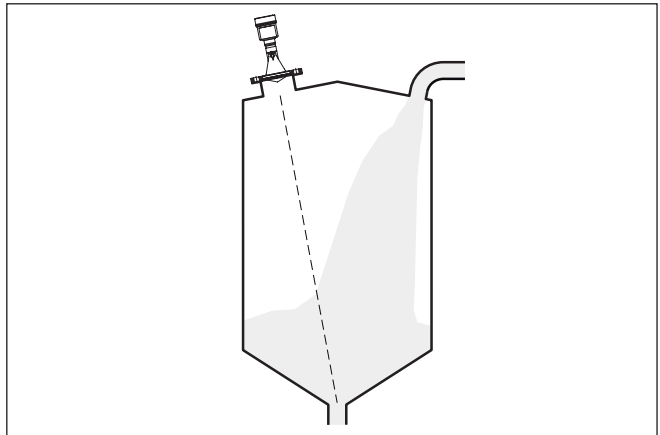

Fig. 11: Mounting of the radar sensor with inflowing medium with filling from the top

**Lateral filling:** With bulk solids silos with lateral pneumatic filling, mounting should not be in the filling stream as the microwave signal will be interfered. The optimum mounting position is next to the filling. To avoid strong pollution, the distance to the filter or dust extraction must be as big as possible.

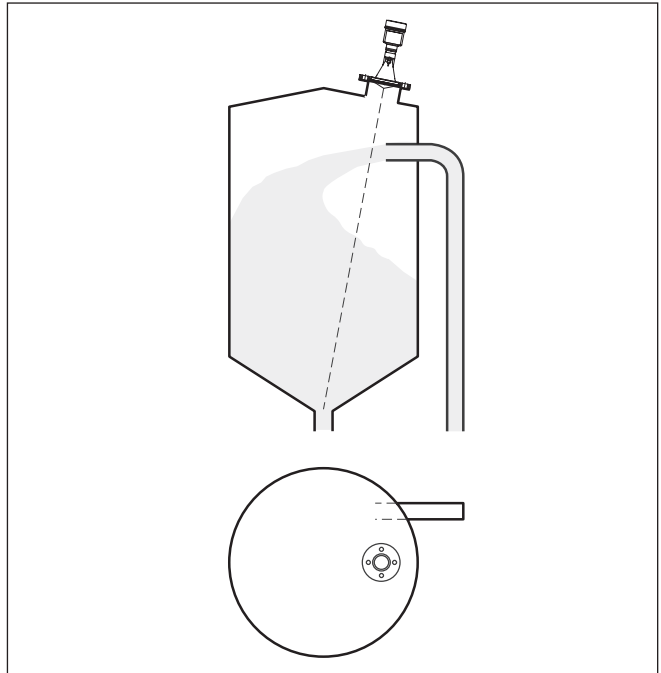

Fig. 12: Mounting of the radar sensor with inflowing medium with lateral filling

#### Socket with plastic horn antenna

A corresponding collar flange for DN 80 (ASME 3" or JIS 80) as well as a suitable adapter flange are available for mounting VEGAPULS 67.

With the housing versions plastic, aluminium single chamber and stainless steel, the collar flange can be placed directly over the housing. With the aluminium double chamber housing, retroactive mounting in this way is not possible - the mounting type must be specified with the order.



#### Information:

The socket should be as short as possible and the socket end rounded. Thus, false reflections by the vessel socket are reduced.

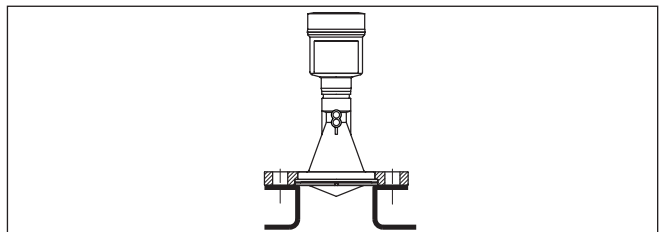
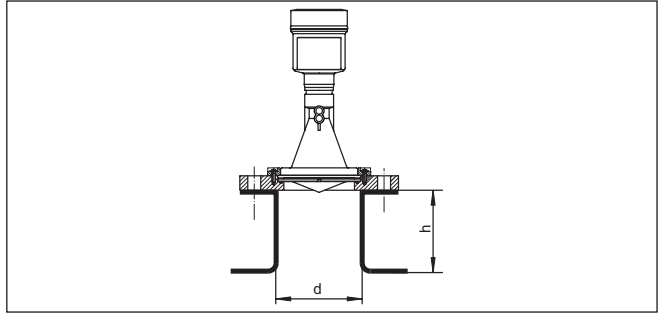

Fig. 13: Recommended socket mounting

If the medium has good reflective properties, VEGAPULS 67 can also be mounted on a longer socket piece. Recommended values for socket heights are specified in the following illustration. You must carry out a false echo storage afterwards.



The below charts specify the max. socket piece length  $h$  depending on the diameter  $d$ .

Socket diameter $d$	Socket length $h$
80 mm	300 mm
100 mm	400 mm
150 mm	500 mm

Socket diameter $d$	Socket length $h$
3"	11.8 in
4"	15.8 in
6"	19.7 in



**Tip:**

In new facilities it is useful to incline the vessel socket in the direction of the outlet. False reflections from the vessel wall are thus reduced and measurement all the way down to the bottom of the conical outlet is possible.

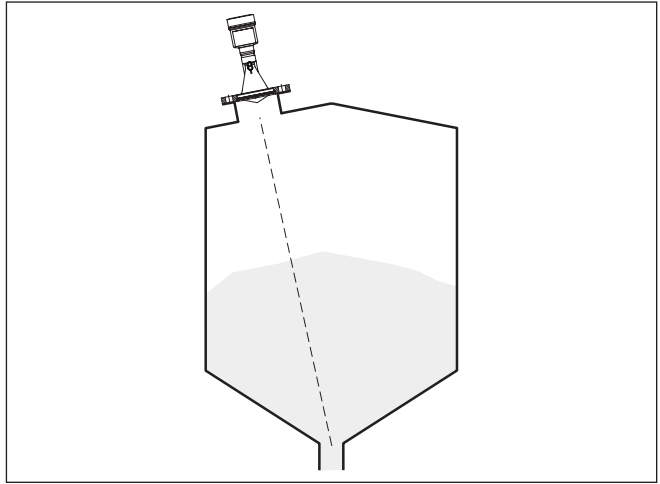

Fig. 15: Alignment in silos

### Orientation

To detect nearly the complete vessel volume the sensor should be directed in such a way that the measuring beam reaches the lowest level in the vessel, i.e. the outlet.

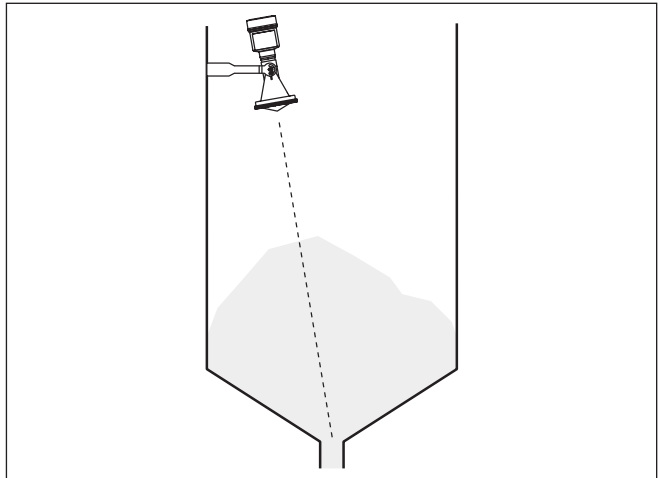

Fig. 16: Mounting in open vessel

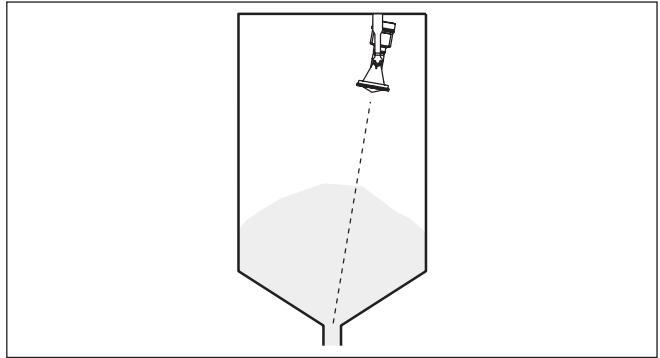

Fig. 17: Mounting on the vessel ceiling



**Caution:**

When mounting on the vessel ceiling make sure that the sensor does not overfill. Depending on the measured product, this can cause a mechanical damage.

In a cylindrical silo with conical outlet, the mounting is carried out on a socket. It should be positioned on one third up to the half of the vessel radius.

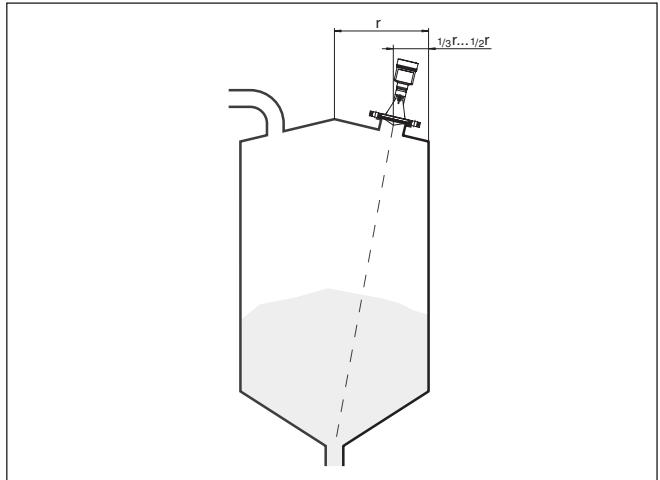

Fig. 18: Mounting position and orientation

**Material heaps**

Large material heaps are best measured with several instruments, which can be mounted on e.g. traverse cranes. For this type of application it is advantageous to orient the sensor perpendicular to the bulk solid surface.

The sensors do not influence each other.

**Information:**

Keep in mind that for these applications, the sensors are designed for relatively slow level changes. If the sensor is used on a movable boom, the max. measuring rate must be observed (see chapter "Technical data").

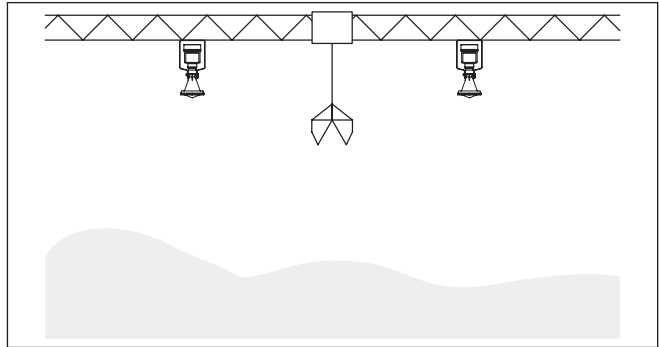

Fig. 19: Radar sensors on traverse crane

**Vessel installations**

The mounting location of the radar sensor should be a place where no other equipment or fixtures cross the path of the microwave signals.

Vessel installations, such as e.g. ladders, limit switches, heating spirals, struts, etc., can cause false echoes and impair the useful echo. Make sure when planning your measuring site that the radar sensor has a "clear view" to the measured product.

In case of existing vessel installations, a false echo storage should be carried out during setup.

If large vessel installations such as struts or supports cause false echoes, these can be attenuated through supplementary measures. Small, inclined sheet metal baffles above the installations scatter the radar signals and prevent direct interfering reflections.

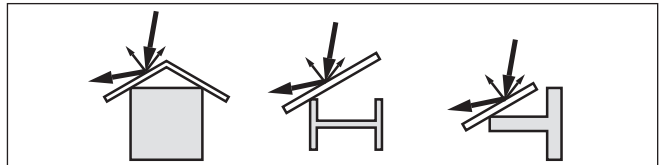

Fig. 20: Cover smooth profiles with deflectors

**Agitators**

If there are agitators in the vessel, a false signal suppression should be carried out with the agitators in motion. This ensures that the interfering reflections from the agitators are saved with the blades in different positions.

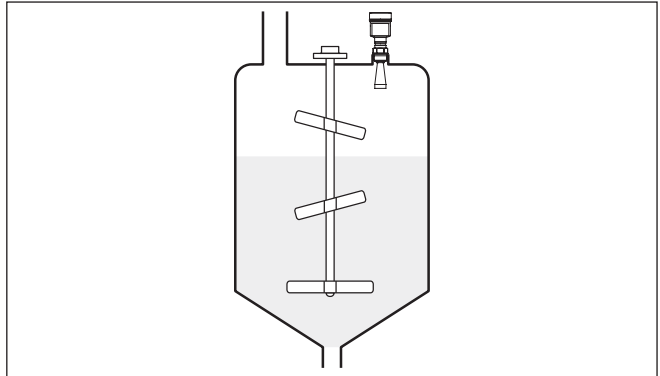

Fig. 21: Agitators

**Installation in subsurface enclosures**

For level measurements in concrete silos, the sensors are often mounted in protective boxes. These boxes can be for example metallic, closed subsurface enclosures.

Minimal amounts of stray radiation from the sensor can be reflected and strengthened by the walls of the subsurface enclosures. In the case of sensors with plastic housings, this can lead to coupling disturbances. This is avoided by using sensor housings of aluminium or stainless steel as well as electromagnetic absorber material in subsurface enclosures.

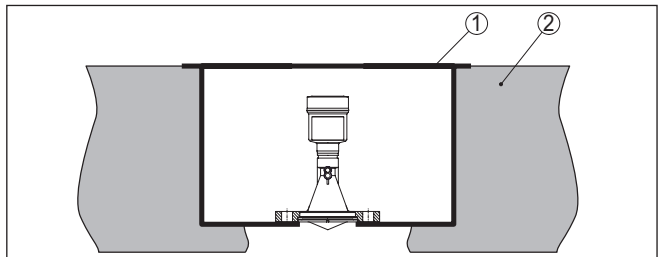

Fig. 22: Mounting of the instrument in an subsurface enclosure

- 1 Subsurface enclosure
- 2 Concrete bottom

**Mounting in multiple chamber silo**

The silo walls of multiple chamber silos are often made of profile walls, like e.g. profile sheeting, to ensure the required stability. If the radar sensor is mounted very close to a heavily structured vessel wall, substantial interfering reflections can be generated. Hence the sensor should be mounted at a large distance from the separating wall.

The optimum mounting position is on the outer wall of the silo with the sensor oriented towards the outlet in the silo center.

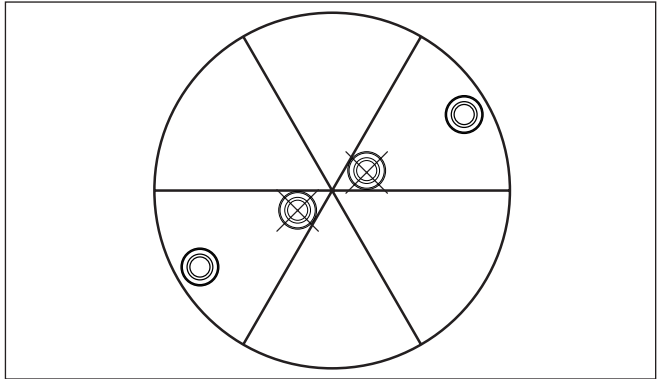

Fig. 23: Installation and orientation in multiple chamber silos

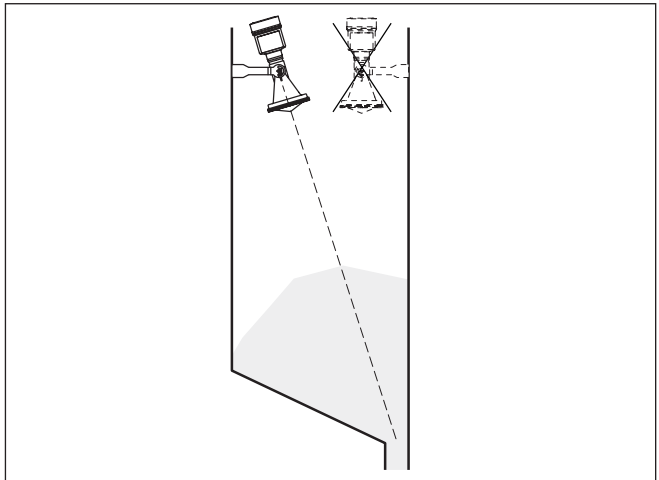

Fig. 24: Installation and orientation in multiple chamber silos

### Air rinsing

Air rinsing is useful for avoiding buildup, particularly when there is strong condensation. Since VEGAPULS 67 has no direct rinsing air connection, a separate rinsing air connection must be provided in the mounting socket. By inclining this connection towards the top, a particularly effective cleaning of the antenna cover is achieved.

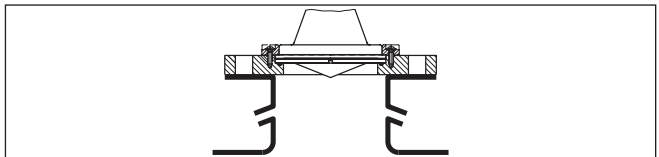

Fig. 25: Purging air connection



## 5 Connecting to power supply

### 5.1 Preparing the connection

#### Safety instructions

Always keep in mind the following safety instructions:

- Connect only in the complete absence of line voltage
- If overvoltage surges are expected, overvoltage arresters should be installed

#### Voltage supply

Power supply and current signal are carried on the same two-wire cable. The voltage supply range can differ depending on the instrument version.

The data for power supply are specified in chapter "*Technical data*".

Provide a reliable separation between the supply circuit and the mains circuits according to DIN VDE 0106 part 101.

Keep in mind the following additional factors that influence the operating voltage:

- Output voltage of the power supply unit can be lower under nominal load (with a sensor current of 20.5 mA or 22 mA in case of fault message)
- Influence of additional instruments in the circuit (see load values in chapter "*Technical data*")

#### Connection cable

The instrument is connected with standard two-wire cable without screen. If electromagnetic interference is expected which is above the test values of EN 61326-1 for industrial areas, screened cable should be used.

For instruments with housing and cable gland, use cable with round cross-section. A cable outer diameter of 5 ... 9 mm (0.2 ... 0.35 in) ensures the seal effect of the cable gland. If you are using cable with a different diameter, exchange the seal or use a suitable cable gland.

We generally recommend the use of screened cable for HART multi-drop mode.

#### Cable gland ½ NPT

With plastic housing, the NPT cable gland or the Conduit steel tube must be screwed without grease into the threaded insert.

Max. torque for all housings see chapter "*Technical data*"

#### Cable screening and grounding

If screened cable is necessary, connect the cable screen on both ends to ground potential. In the sensor, the screen must be connected directly to the internal ground terminal. The ground terminal on the outside of the housing must be connected to the potential equalisation (low impedance).

If potential equalisation currents are expected, the connection on the processing side must be made via a ceramic capacitor (e. g. 1 nF, 1500 V). The low frequency potential equalisation currents are thus suppressed, but the protective effect against high frequency interference signals remains.

**Warning:**

Significant potential differences exist inside galvanization plants as well as on vessels with cathodic corrosion protection. Considerable equalisation currents can flow over the cable screen if the screen is grounded on both ends.

To avoid this in such applications, the cable screen must be connected to ground potential only at one end (in the switching cabinet). The cable screen must **not** be connected to the internal ground terminal in the sensor and the outer ground terminal on the housing must **not** be connected to the potential equalisation!

**Information:**

The metal parts of the instrument (process fitting, transmitter, concentric tube, etc.) are conductively connected with the inner and outer ground terminal on the housing. This connection exists either directly via connecting metallic parts or, in case of instruments with external electronics, via the screen of the special connection cable.

You can find specifications on the potential connections inside the instrument in chapter "*Technical data*".

**Cable screening and grounding**

If screened cable is necessary, connect the cable screen on both ends to ground potential. In the sensor, the screen must be connected directly to the internal ground terminal. The ground terminal on the outside of the housing must be connected to the potential equalisation (low impedance).

If potential equalisation currents are expected, the connection on the processing side must be made via a ceramic capacitor (e. g. 1 nF, 1500 V). The low frequency potential equalisation currents are thus suppressed, but the protective effect against high frequency interference signals remains.

**5.2 Connecting****Connection technology**

The voltage supply and signal output are connected via the spring-loaded terminals in the housing.

The connection to the indicating and adjustment module or to the interface adapter is carried out via contact pins in the housing.

**Information:**

The terminal block is pluggable and can be removed from the electronics. To do this, lift the terminal block with a small screwdriver and pull it out. When inserting the terminal block again, you should hear it snap in.

**Connection procedure**

Proceed as follows:

1. Unscrew the housing cover
2. If an indicating and adjustment module is installed, remove it by turning it slightly to the left.
3. Loosen compression nut of the cable entry
4. Remove approx. 10 cm (4 in) of the cable mantle, strip approx. 1 cm (0.4 in) of insulation from the ends of the individual wires

5. Insert the cable into the sensor through the cable entry

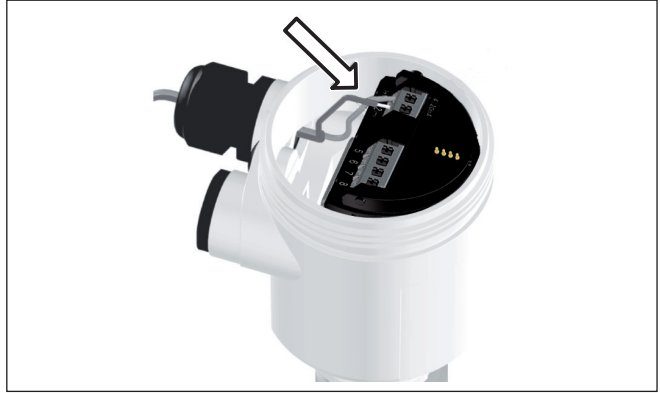

Fig. 26: Connection steps 5 and 6

6. Insert the wire ends into the terminals according to the wiring plan



**Information:**

Solid cores as well as flexible cores with cable end sleeves are inserted directly into the terminal openings. In case of flexible cores without end sleeves, press the terminal head with a small screwdriver; the terminal opening is freed. When the screwdriver is released, the terminal closes again.

You can find further information to the max. wire cross-section under "*Technical data/Electromechanical data*"

7. Check the hold of the wires in the terminals by lightly pulling on them
  8. Connect the screen to the internal ground terminal, connect the outer ground terminal to potential equalisation
  9. Tighten the compression nut of the cable entry. The seal ring must completely encircle the cable
  10. Place probably existing indicating and adjustment module back on
  11. Screw the housing cover back on
- The electrical connection is hence finished.

### 5.3 Wiring plan, single chamber housing



The following illustration applies to the non-Ex as well as to the Ex-ia version.

## Electronics compartment

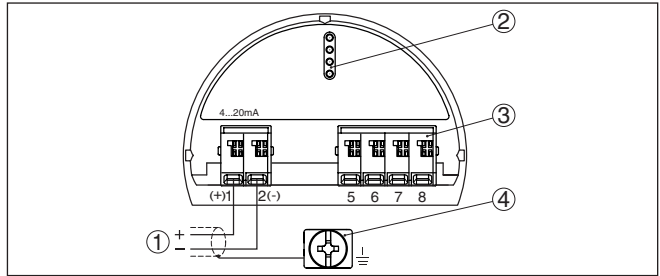

Fig. 27: Electronics and connection compartment, single chamber housing

- 1 Voltage supply, signal output
- 2 For indicating and adjustment module or interface adapter
- 3 For external indicating and adjustment unit
- 4 Ground terminal for connection of the cable screen

## 5.4 Wiring plan, double chamber housing



The following illustrations apply to the non-Ex as well as to the Ex-ia version.

## Electronics compartment

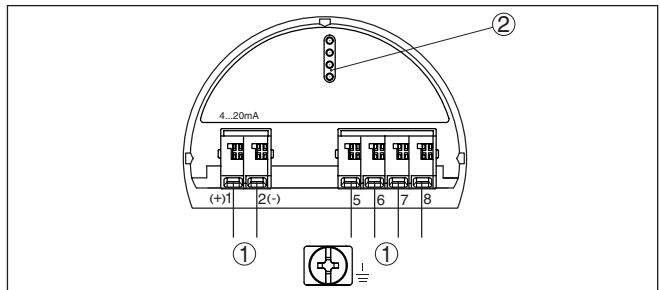

Fig. 28: Electronics compartment, double chamber housing

- 1 Internal connection to the connection compartment
- 2 For indicating and adjustment module or interface adapter

**Information:**

The connection of an external indicating and adjustment unit is not possible with this double chamber housing.

Connection compartment

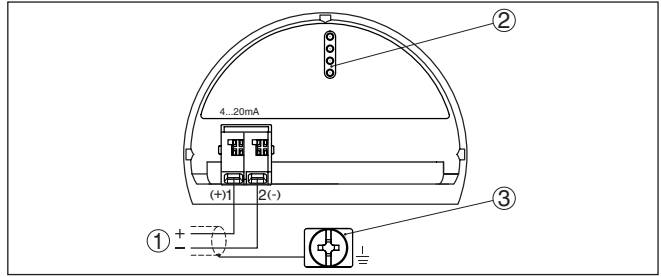

Fig. 29: Connection compartment, double chamber housing

- 1 Voltage supply/Signal output
- 2 For indicating and adjustment module or interface adapter
- 3 Ground terminal for connection of the cable screen

Radio module PLICSMOBILE integrated in the connection compartment

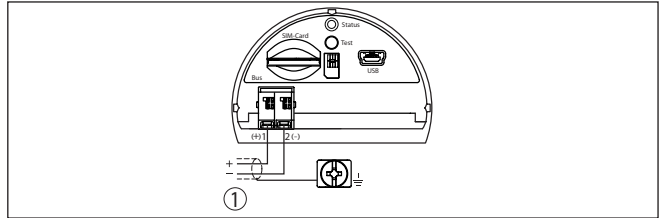

Fig. 30: Connection of the voltage supply of the radio module

- 1 Voltage supply

You can find detailed information for connection in the supplementary instructions "PLICSMOBILE GSM/GPRS radio module".

### 5.5 Wiring plan, double chamber housing Ex d

Electronics compartment

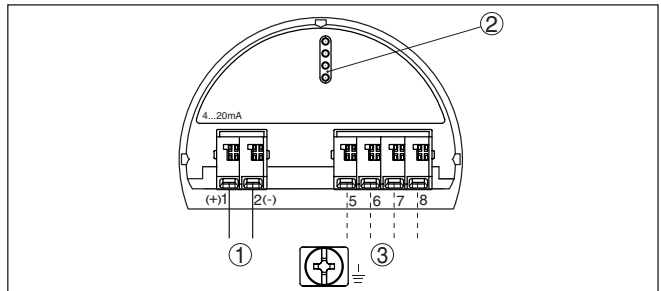

Fig. 31: Electronics compartment, double chamber housing

- 1 Internal connection to the connection compartment
- 2 For indicating and adjustment module or interface adapter
- 3 Internal connection to the plug connector for external indicating and adjustment unit (optional)

**Connection compartment**

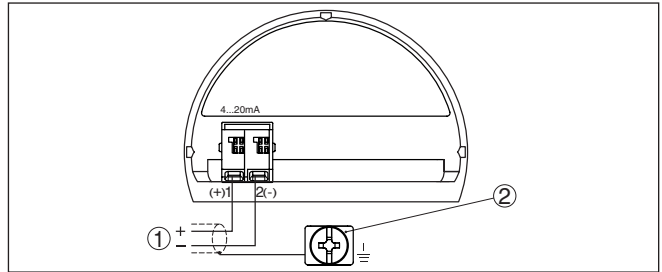

Fig. 32: Connection compartment, Ex-d double chamber housing

- 1 Voltage supply, signal output
- 2 Ground terminal for connection of the cable screen

**Plug M12 x 1 for external indicating and adjustment unit**

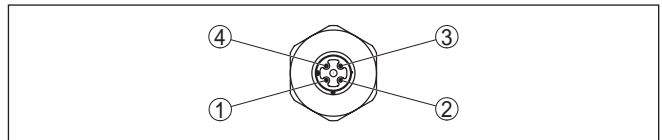

Fig. 33: Top view of the plug connector

- 1 Pin 1
- 2 Pin 2
- 3 Pin 3
- 4 Pin 4

Contact pin	Colour connection cable in the sensor	Terminal, electronics module
Pin 1	Brown	5
Pin 2	White	6
Pin 3	Blue	7
Pin 4	Black	8

**5.6 Wiring plan - version IP 66/IP 68, 1 bar**

**Wire assignment, connection cable**

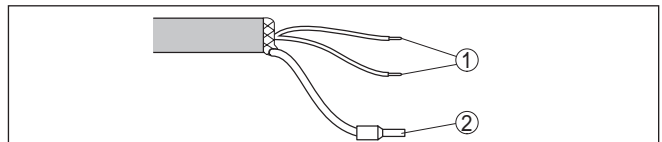

Fig. 34: Wire assignment fix-connected connection cable

- 1 brown (+) and blue (-) to power supply or to the processing system
- 2 Shielding

**5.7 Switch-on phase**

After connecting the instrument to power supply or after a voltage recurrence, the instrument carries out a self-check for approx. 30 s:

- Internal check of the electronics

- Indication of the instrument type, hardware and software version, measurement loop name on the display or PC
- Indication of the status message "*F 105 Determine measured value*" on the display or PC
- The output signal jumps to the set error current

As soon as a plausible measured value is found, the corresponding current is outputted to the signal cable. The value corresponds to the actual level as well as the settings already carried out, e.g. factory setting.

## 6 Set up with the indicating and adjustment module

### 6.1 Insert indicating and adjustment module

The indicating and adjustment module can be inserted into the sensor and removed any time. Four positions displaced by 90° can be selected. It is not necessary to interrupt the power supply.

Proceed as follows:

1. Unscrew the housing cover
2. Place the indicating and adjustment module in the requested position onto the electronics and turn to the right until it snaps in
3. Screw housing cover with inspection window tightly back on

Removal is carried out in reverse order.

The indicating and adjustment module is powered by the sensor, an additional connection is not necessary.



Fig. 35: Insertion of the indicating and adjustment module with single chamber housing into the electronics compartment



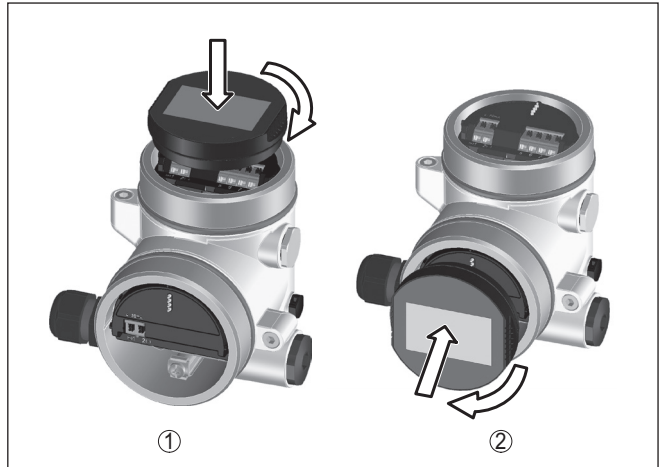

Fig. 36: Insertion of the indicating and adjustment module with double chamber housing

- 1 In the electronics compartment
- 2 In the connection compartment (with Ex-d-ia version not possible)



**Note:**

If you intend to retrofit the instrument with an indicating and adjustment module for continuous measured value indication, a higher cover with an inspection glass is required.

**6.2 Adjustment system**

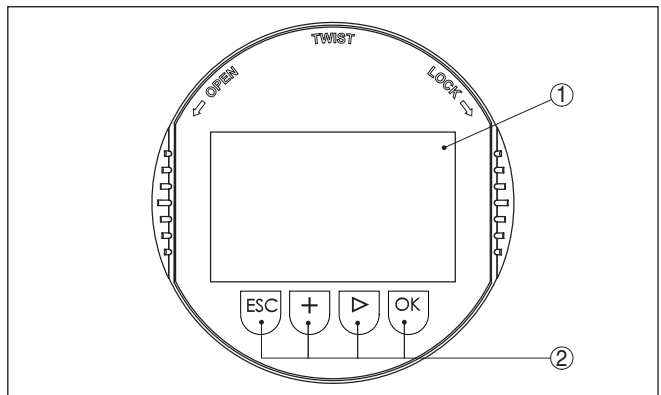

Fig. 37: Indicating and adjustment elements

- 1 LC display
- 2 Adjustment keys

**Key functions**

- **[OK]** key:
  - Move to the menu overview
  - Confirm selected menu

- Edit parameter
- Save value
- [**->**] key:
  - Presentation change measured value
  - Select list entry
  - Select editing position
- [**+**] key:
  - Change value of the parameter
- [**ESC**] key:
  - interrupt input
  - Jump to next higher menu

## Adjustment system

The sensor is adjusted via the four keys of the indicating and adjustment module. The LC display indicates the individual menu items. The functions of the individual keys are shown in the above illustration. Approx. 10 minutes after the last pressing of a key, an automatic reset to measured value indication is triggered. Any values not confirmed with [**OK**] will not be saved.

### 6.3 Parameter adjustment

Through the parameter adjustment the instrument is adapted to the application conditions. The parameter adjustment is carried out via an adjustment menu.

## Main menu

The main menu is divided into five sections with the following functions:

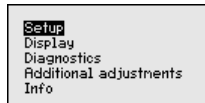

**Setup:** Settings, e.g., for measurement loop name, medium, application, vessel, adjustment, signal output

**Display:** Settings, e.g., for language, measured value display, lighting

**Diagnosis:** Information, e.g. on the instrument status, pointer, reliability, simulation, echo curve

**Further settings:** Instrument unit, false signal suppression, linearisation curve, reset, date/time, reset, copy function

**Info:** Instrument name, hardware and software version, calibration date, instrument features



#### Information:

In this operating instructions manual, the instrument-specific parameters in the menu sections "*Setup*", "*Diagnosis*" and "*Additional settings*" are described. The general parameters in these menu section are described in the operating instructions manual "*Indicating and adjustment module*".

You can find in the operating instructions manual "*Indicating and adjustment module*" also the description of the menu sections "*Display*" and "*Info*".

In the main menu point "*Setup*", the individual submenu points should be selected subsequently and provided with the correct parameters to ensure the optimum adjustment of the measurement. The procedure is described in the following.

**Setup/Medium**

Each medium has different reflection properties. With liquids, further interfering factors are fluctuation product surface and foam generation. With bulk solids, these are dust generation, material cone and additional echoes from the vessel wall.

To adapt the sensor to these different measuring conditions, the selection "*Liquid*" or "*Bulk solid*" should be made in this menu item.

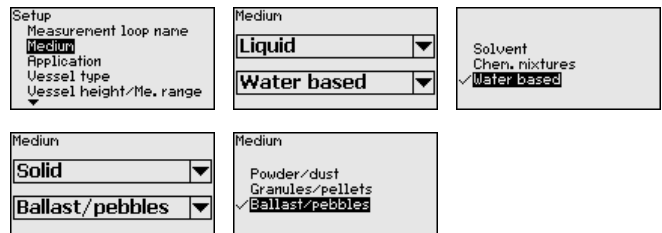

Through this selection, the sensor is adapted perfectly to the product and measurement reliability, particularly in products with poor reflective properties, is considerably increased.

Enter the requested parameters via the appropriate keys, save your settings with **[OK]** and jump to the next menu item with the **[ESC]** and the **[->]** key.

**Setup/Application**

In addition to the medium, also the application, i.e. the measuring site, can influence the measurement.

With this menu item, the sensor can be adapted to the applications. The adjustment possibilities depend on the selection "*Liquid*" or "*Bulk solid*" under "*Medium*".

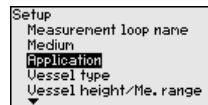

The following options are available when "*Liquid*" is selected:



The selection "Standpipe" opens a new window in which the inner diameter of the applied standpipe is entered.

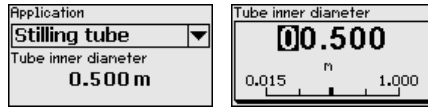

The following features form the basis of the applications:

#### Storage tank:

- Setup: large-volumed, upright cylindrical, spherical
- Product speed: slow filling and emptying
- Process/measurement conditions:
  - Condensation
  - Smooth product surface
  - Max. requirement to the measurement accuracy

#### Storage tanke with product circulation:

- Setup: large-volumed, upright cylindrical, spherical
- Product speed: slow filling and emptying
- Vessel: small laterally mounted or large top mounted stirrer
- Process/measurement conditions:
  - Relatively smooth product surface
  - Max. requirement to the measurement accuracy
  - Condensation
  - Slight foam generation
  - Overfilling possible

#### Storage tank on ships (Cargo Tank):

- Product speed: slow filling and emptying
- Vessel:
  - Installations in the bottom section (bracers, heating spirals)
  - High sockets 200 ... 500 mm, also with large diameters
- Process/measurement conditions:
  - Condensation, buildup by movement
  - Max. requirement on measurement accuracy from 95 %

#### Stirrer vessel (reactor):

- Setup: all vessel sizes possible
- Product speed:
  - Fast to slow filling possible
  - Vessel is very often filled and emptied
- Vessel:
  - Socket available
  - Large agitator blades of metal
  - Vortex breakers, heating spirals
- Process/measurement conditions:
  - Condensation, buildup by movement
  - Strong spout generation
  - Very agitated surface, foam generation

#### Dosing vessel:

- Setup: all vessel sizes possible
- Product speed:

- Fast filling and emptying
- Vessel is very often filled and emptied
- Vessel: narrow installation situation
- Process/measurement conditions:
  - Condensation, buildup on the antenna
  - Foam generation

**Standpipe:**

- Product speed: very fast filling and emptying
- Vessel:
  - Vent hole
  - Joins like flanges, weld joints
  - Shifting of the running time in the tube
- Process/measurement conditions:
  - Condensation
  - Buildup

**Bypass:**

- Product speed:
  - Fast up to slow filling with short up to long bypass tube possible
  - Often the level is hold via a control facility
- Vessel:
  - Lateral outlets and inlets
  - Joins like flanges, weld joints
  - Shifting of the running time in the tube
- Process/measurement conditions:
  - Condensation
  - Buildup
  - Separation of oil and water possible
  - Overfilling into the antenna possible

**Plastic tank:**

- Vessel:
  - Measurement fix mounted or integrated
  - Measurement depending on the application through the vessel top
  - With empty vessel, the measurement can be carried out through the bottom
- Process/measurement conditions:
  - Condensation on the plastic ceiling
  - In outside facilities water and snow on the vessel top possible

**Transportable plastic tank:**

- Vessel:
  - Material and thickness different
  - Measurement through the vessel top
- Process/measurement conditions:
  - Measured value jump with vessel change

**Open water (gauge measurement):**

- Gauge rate of change: slow gauge change
- Process/measurement conditions:
  - Distance sensor to water surface to big

- Extreme damping of output signal due to wave generation
- Ice and condensation on the antenna possible
- Spiders and insect nestle in the antennas
- Floating material and animals sporadically on the water surface

**Open flume (flow measurement):**

- Gauge rate of change: slow gauge change
- Process/measurement conditions:
  - Ice and condensation on the antenna possible
  - Spiders and insect nestle in the antennas
  - Smooth water surface
  - Exact measurement result required
  - Distance to the water surface normally relatively high

**Rain water overfall (weir):**

- Gauge rate of change: slow gauge change
- Process/measurement conditions:
  - Ice and condensation on the antenna possible
  - Spiders and insect nestle in the antennas
  - Turbulent water surface
  - Sensor flooding possible

**Demonstration:**

- Adjustment for all applications which are not typically level measurement
- Sensor accepts all measured value changes within the measuring range immediately
- Typical applications:
  - Instrument demonstration
  - Object recognition/monitoring (additional settings required)

**Caution:**

If a separation of liquids with different dielectric figure occurs in the vessel, for example through condensation, the radar sensor can detect under certain circumstances only the medium with the higher dielectric figure. Keep in mind that layer interfaces can cause faulty measurements.

If you want to measure the total height of both liquids reliably, please contact our service department or use an instrument specially designed for interface measurement.

The following options are available when "Bulk solid" is selected:

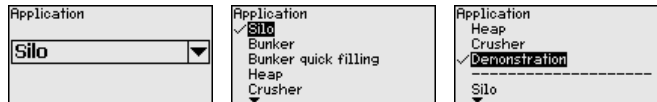

The following features form the basis of the applications:

**Silo (slim and high):**

- Vessel of metal: weld joints
- Process/measurement conditions:
  - Filling too close to the sensor
  - System noise with completely empty silo increased

- Automatic false signal suppression with partly filled vessel

**Bunker (large-volumed):**

- Vessel of concrete or metal:
  - Structured vessel walls
  - Installations present
- Process/measurement conditions:
  - Large distance to the medium
  - Large angles of repose

**Bunker with fast filling:**

- Vessel of concrete or metal, also multiple chamber silo:
  - Structured vessel walls
  - Installations present
- Process/measurement conditions:
  - Measured value jumps, e.g. by truck loading
  - Large distance to the medium
  - Large angles of repose

**Heap:**

- Sensor mounting on movable conveyor belts
- Detection of the heap profile
- Height detection during filling
- Process/measurement conditions:
  - Measured value jumps, e.g. by the profile of the heap or traverses
  - Large angles of repose
  - Measurement near the filling stream

**Crusher:**

- Vessel: installations, wear and protective facilities available
- Process/measurement conditions:
  - Measured value jumps, e.g. by truck loading
  - Fast reaction time
  - Large distance to the medium

**Demonstration:**

- Adjustment for all applications which are not typically level measurement
- Sensor accepts all measured value changes within the measuring range immediately
- Typical applications:
  - Instrument demonstration
  - Object recognition/monitoring (additional settings required)

Through this selection, the sensor is adapted optimally to the application or the location and measurement reliability under the various basic conditions is increased considerably.

Enter the requested parameters via the appropriate keys, save your settings with **[OK]** and jump to the next menu item with the **[ESC]** and the **[->]** key.

### Setup/Vessel height, measuring range

With this selection, the operating range of the sensor is adapted to the vessel height and the reliability with different frame conditions is increased considerably.

Independent from this, the min. adjustment must be carried out.

Setup Medium Application <b>Vessel type</b> Vessel height/Meas. range Max. adjustment ▼	Vessel height/Meas. range  <b>35.000 m</b>
---	--

Enter the requested parameters via the appropriate keys, save your settings with **[OK]** and jump to the next menu item with the **[ESC]** and the **[->]** key.

### Setup/Vessel form

Also the vessel form can influence the measurement apart from the medium and the application. To adapt the sensor to these measurement conditions, this menu item offers you different options for vessel bottom and ceiling in case of certain applications.

Setup Medium Application <b>Vessel type</b> Vessel height/Meas. range Max. adjustment ▼	Vessel type Vessel top <b>Dished boiler</b>	Vessel bottom <input checked="" type="checkbox"/> <b>Straight</b> <input type="checkbox"/> Conical <input type="checkbox"/> Angular
Vessel top  <input type="checkbox"/> Straight <input checked="" type="checkbox"/> <b>Dished boiler</b>		

Enter the requested parameters via the appropriate keys, save your settings with **[OK]** and jump to the next menu item with the **[ESC]** and the **[->]** key.

### Setup/Adjustment

Since a radar sensor is a distance measuring instrument, the distance from the sensor to the product surface is measured. For indication of the real level, an allocation of the measured distance to the percentage height must be carried out.

To perform the adjustment, enter the distance with full and empty vessel, see the following example:



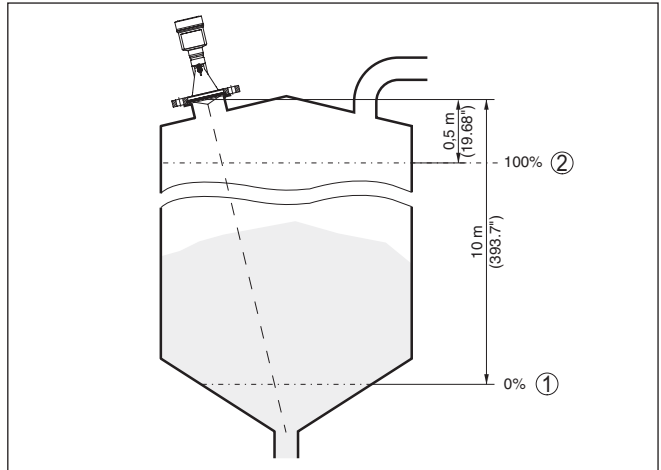

Fig. 38: Parameter adjustment example min./max. adjustment

- 1 Min. level = max. meas. distance
- 2 Max. level = min. meas. distance

If these values are not known, an adjustment with the distances of for example 10 % and 90 % is possible. Starting point for these distance specifications is always the seal surface of the thread or flange. By means of these settings, the real level will be calculated.

The real product level during this adjustment is not important, because the min./max. adjustment is always carried out without changing the product level. These settings can be made ahead of time without the instrument having to be installed.

**Setup/Min. adjustment**

Proceed as follows:

1. Select the menu item "Setup" with [->] and confirm with [OK].  
Now select with [->] the menu item "Min. adjustment" and confirm with [OK].

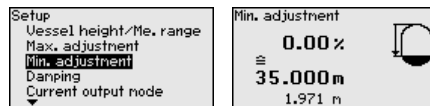

2. Edit the percentage value with [OK] and set the cursor to the requested position with [->].

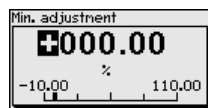

3. Set the requested percentage value with [+ ] and save with [OK].  
The cursor jumps now to the distance value.

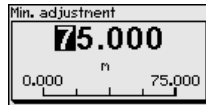

4. Enter the suitable distance value in m for the empty vessel (e.g. distance from the sensor to the vessel bottom) corresponding to the percentage value.
5. Save settings with **[OK]** and move with **[ESC]** and **[->]** to the max. adjustment.

### Setup/Max. adjustment

Proceed as follows:

1. Select with **[->]** the menu item max. adjustment and confirm with **[OK]**.

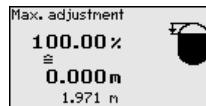
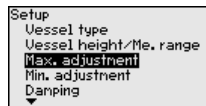

2. Prepare the percentage value for editing with **[OK]** and set the cursor to the requested value position with **[->]**.

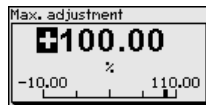

3. Set the requested percentage value with **[+]** and save with **[OK]**. The cursor jumps now to the distance value.

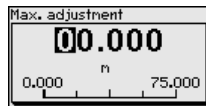

4. Enter the appropriate distance value in m (corresponding to the percentage value) for the full vessel. Keep in mind that the max. level must lie below the min. distance to the antenna edge.
5. Save settings with **[OK]**

### Diagnosis/Peak value

The respective min. and max. measured value is saved in the sensor. The values are displayed in the menu item "Peak values".

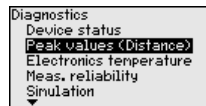
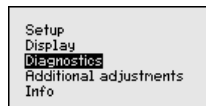

### Diagnosis/Measurement reliability

When non-contact level sensors are used, the measurement can be influenced by the respective process conditions. In this menu item, the measurement reliability of the level echo is displayed as dB value. The measurement reliability equals signal strength minus noise. The higher the value, the more reliable the measurement. With a functioning measurement, the values are > 10 dB.

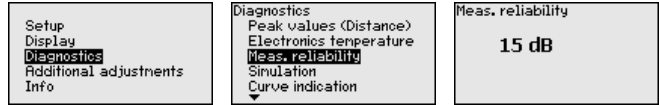

**Diagnoses/Curve indication**

The "Echo curve" shows the signal strength of the echoes over the measuring range in dB. The signal strength enables an evaluation of the quality of the measurement.

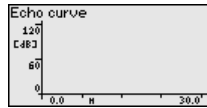
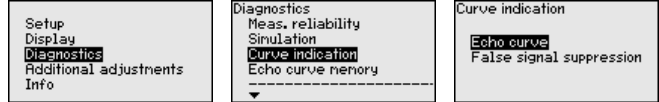

The "False signal suppression" displays the saved false echoes (see menu "Additional settings") of the empty vessel with signal strength in "dB" over the measuring range.

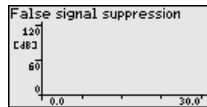
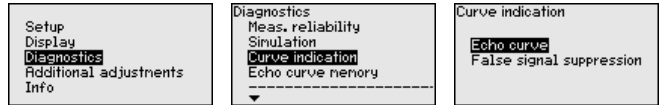

A comparison of echo curve and false signal suppression allows a more accurate conclusion on measurement reliability. The selected curve is continuously updated. With the [OK] key, a submenu with zoom functions is opened:

- "X-Zoom": Zoom function for the meas. distance
- "Y-Zoom": 1, 2, 5 and 10x signal magnification in "dB"
- "Unzoom": Reset the presentation to the nominal measuring range with single magnification

**Diagnosics/Echo curve memory**

With the function "Echo curve memory" the echo curve can be saved at the time of setup. This is generally recommended; for using the As-set Management functions it is absolutely necessary. If possible, the curve should be saved with a low level in the vessel.

With the adjustment software PACTware and the PC, the high resolution echo curve can be displayed and used to recognize signal changes over the operating time. In addition, the echo curve of the setup can be also displayed in the echo curve window and compared with the actual echo curve.

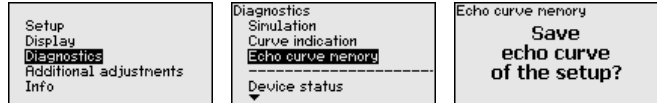

### Additional adjustments/ False signal suppression

The following circumstances cause interfering reflections and can influence the measurement:

- High sockets
- Vessel installations such as struts
- Agitators
- Buildup or welded joints on vessel walls



#### Note:

A false signal suppression detects, marks and saves these false signals so that they are no longer taken into account for level measurement.

This should be done with the low level so that all potential interfering reflections can be detected.

Proceed as follows:

1. Select the menu item "Additional settings" with [->] and confirm with [OK]. With [->] you have to select the menu item "False signal suppression" and confirm with [OK].

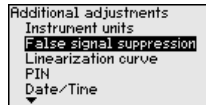

2. Confirm again with [OK].

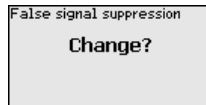

3. Confirm again with [OK].

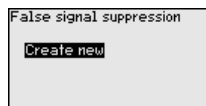

4. Confirm again with [OK] and enter the actual distance from the sensor to the product surface.

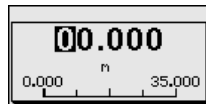

5. All interfering signals in this section are detected by the sensor and stored after confirming with [OK].



#### Note:

Check the distance to the product surface, because if an incorrect (too large) value is entered, the existing level will be saved as false signal. The filling level would then no longer be detectable in this area.

If a false signal suppression has already been created in the sensor, the following menu window appears when selecting "False signal suppression":

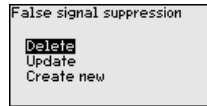

The menu item "Delete" is used to completely delete an already created false signal suppression. This is useful if the saved false signal suppression no longer matches the metrological conditions in the vessel.

The menu item "Extend" is used to extend an already created false signal suppression. This is useful if a false signal suppression was carried out with a too high level and not all false signals could be detected. When selecting "Extend", the distance to the product surface of the created false signal suppression is displayed. This value can now be changed and the false signal suppression can be extended to this range.

**Additional adjustments/  
Linearization curve**

A linearization is necessary for all vessels in which the vessel volume does not increase linearly with the level - e.g. in a horizontal cylindrical or spherical tank - and the indication or output of the volume is required. Corresponding linearization curves are preprogrammed for these vessels. They represent the correlation between the level percentage and vessel volume.

By activating the appropriate curve, the volume percentage of the vessel is displayed correctly. If the volume should not be displayed in percent but e.g. in l or kg, a scaling can be also set in the menu item "Display".

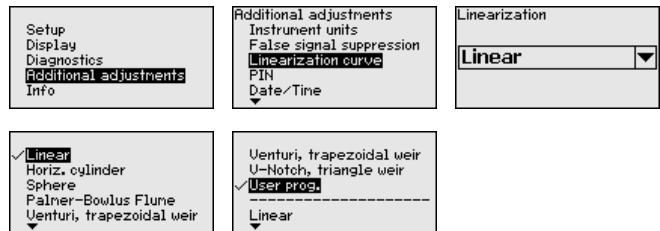

Enter the requested parameters via the appropriate keys, save your settings and jump to the next menu item with the **[ESC]** and **[->]** key.



**Caution:**

Note the following if the instrument with corresponding approval is used as part of an overfill protection system according to WHG:

If a linearisation curve is selected, the measuring signal is no longer linearly proportional to the level. This must be taken into consideration by the user, particularly when setting the switching point on the level switch.

**Additional adjustments  
- Reset**

With a reset, certain parameter adjustments carried out by the user are reset.



The following reset functions are available:

**Delivery status:** Restoring the parameter settings at the time of shipment from the factory incl. the order-specific settings. A created false signal suppression, user-programmable linearization curve as well as the measured value memory will be deleted.

**Basic settings:** Resetting the parameter settings incl. special and laboratory parameters to the default values of the respective instrument. A created false signal suppression, user programmable linearization curve as well as the measured value memory will be deleted.

**Setup:** Resetting of the parameter settings to the default values of the respective instrument in the menu item Setup. User-generated false signal suppression, user-programmed linearization curve, measured value memory as well as event memory remain untouched. The linearization is set to linear.

**False signal suppression:** Deleting a previously created false signal suppression. The false signal suppression created in the factory remains active.

**Peak values measured value:** Resetting of the measured min. and max. distances to the actual measured value.

The following table shows the default values of the instrument. Depending on the instrument version, not all menu items are available or differently assigned:

Menu	Menu item	Default value
Setup	Measurement loop name	Sensor
	Medium	Liquid/Water Bulk solids/Crushed stones, gravel
	Applications	Storage tank Silo
	Vessel form	Vessel bottom, dished boiler end Vessel top, dished boiler end
	Vesell height/ Measuring range	Recommended measuring range, see "Technical data" in the supplement
	Min. adjustment	Recommended measuring range, see "Technical data" in the supplement
	Max. adjustment	0,000 m(d)
	Damping	0.0 s
	Current output mode	4 ... 20 mA, < 3.6 mA
	Current output Min./Max.	Min. current 3.8 mA, max. current 20.5 mA
	Lock operation	Released

Menu	Menu item	Default value
Display	Language	Like order
	Displayed value	Distance
	Display unit	m
	Scaling size	Volume l
	Scaling	0.00 lin %, 0 l 100.00 lin %, 100 l
	Backlight	Switched off
Additional adjustments	Distance unit	m
	Temperature unit	°C
	Probe length	Length of the standpipe Ex factory
	Linearisation curve	Linear
	HART mode	Standard Address 0

### 6.4 Saving the parameter adjustment data

We recommend noting the adjusted data, e.g. in this operating instructions manual, and archiving them afterwards. They are thus available for multiple use or service purposes.

If the instrument is equipped with an indicating and adjustment module, the data in the sensor can be saved in the indicating and adjustment module. The procedure is described in the operating instructions manual "*Indicating and adjustment module*" in the menu item "*Copy sensor data*". The data remain there permanently even if the sensor power supply fails.

The following data or settings for adjustment of the indicating and adjustment module are saved:

- All data of the menu "*Setup*" and "*Display*"
- In the menu "*Additional adjustments*" the items "*Sensor-specific units, temperature unit and linearization*"
- The values of the user programmable linearisation curve

The function can also be used to transfer settings from one instrument to another instrument of the same type. If it is necessary to exchange a sensor, the indicating and adjustment module is inserted into the replacement instrument and the data are likewise written into the sensor via the menu item "*Copy sensor data*".

## 7 Setup with PACTware

### 7.1 Connect the PC

Via the interface adapter directly on the sensor

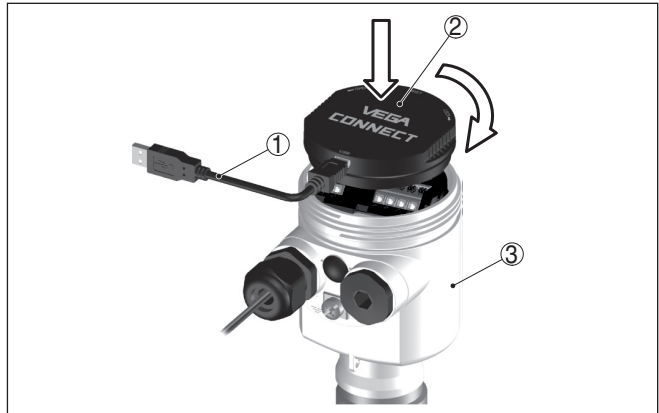

Fig. 39: Connection of the PC directly to the sensor via the interface adapter

- 1 USB cable to the PC
- 2 Interface adapter VEGACONNECT 4
- 3 Sensor



#### Information:

The interface adapter VEGACONNECT 3 is not suitable for connection to the sensor.

Via the interface adapter and HART

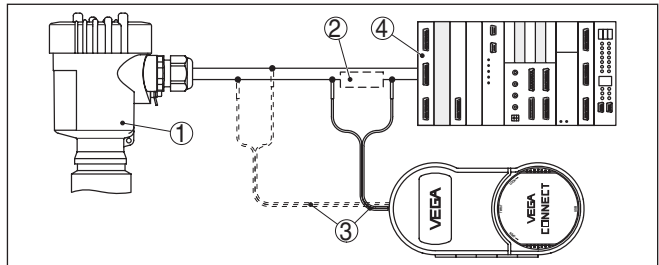

Fig. 40: Connecting the PC via HART to the signal cable

- 1 Sensor
- 2 HART resistance 250  $\Omega$  (optional depending on processing)
- 3 Connection cable with 2 mm pins and terminals
- 4 Processing system/PLC/Voltage supply
- 5 Interface adapter, for example VEGACONNECT 4



#### Note:

With power supply units with integrated HART resistance (internal resistance approx. 250  $\Omega$ ), an additional external resistance is not necessary. This applies, e.g. to the VEGA instruments VEGATRENN 149A, VEGAMET 381, VEGAMET 391. Common Ex separators are also usually equipped with a sufficient current limitation resistance. In



such cases, the interface converter can be connected parallel to the 4 ... 20 mA cable (dashed line in the previous illustration).

## 7.2 Parameter adjustment with PACTware

### Prerequisites

For parameter adjustment of the sensor via a Windows PC, the configuration software PACTware and a suitable instrument driver (DTM) according to FDT standard are required. The up-to-date PACTware version as well as all available DTMs are compiled in a DTM Collection. The DTMs can also be integrated into other frame applications according to FDT standard.



#### Note:

To ensure that all instrument functions are supported, you should always use the latest DTM Collection. Furthermore, not all described functions are included in older firmware versions. You can download the latest instrument software from our homepage. A description of the update procedure is also available in the Internet.

Further setup steps are described in the operating instructions manual "DTM Collection/PACTware" attached to each DTM Collection and which can also be downloaded from the Internet. Detailed descriptions are available in the online help of PACTware and the DTMs.

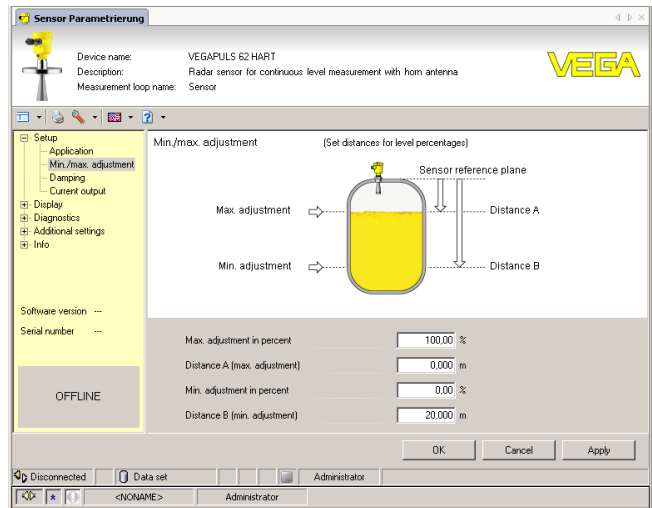

Fig. 41: Example of a DTM view

### Standard/Full version

All device DTMs are available as a free-of-charge standard version and as a full version that must be purchased. In the standard version, all functions for complete setup are already included. An assistant for simple project configuration simplifies the adjustment considerably. Saving/printing the project as well as import/export functions are also part of the standard version.

In the full version there is also an extended print function for complete project documentation as well as a save function for measured value

and echo curves. In addition, there is a tank calculation program as well as a multiviewer for display and analysis of the saved measured value and echo curves.

The standard version is available as a download under [www.vega.com/downloads](http://www.vega.com/downloads) and "*Software*". The full version is available on CD from the agency serving you.

### **7.3 Saving the parameter adjustment data**

We recommend documenting or saving the parameter adjustment data via PACTware. That way the data are available for multiple use or service purposes.

## 8 Set up with other systems

### 8.1 DD adjustment programs

Device descriptions as Enhanced Device Description (EDD) are available for DD adjustment programs such as, for example, AMS™ and PDM.

The files can be downloaded at [www.vega.com/downloads](http://www.vega.com/downloads) under "*Software*".

### 8.2 Communicator 375, 475

Device descriptions for the instrument are available as DD or EDD for parameter adjustment with the Field Communicator 375 or 475.

The files can be downloaded at [www.vega.com/downloads](http://www.vega.com/downloads) under "*Software*".

## 9 Diagnosis, Asset Management and service

### 9.1 Maintenance

If the device is used correctly, no maintenance is required in normal operation.

In some applications, buildup on the antenna system can influence the measuring result. Depending on the sensor and application, make arrangements to avoid strong pollution of the antenna system. If necessary, clean the antenna system in certain intervals.

### 9.2 Measured value and event memory

The instrument has several memories which are available for diagnosis purposes. The data remain even with voltage interruption.

#### Measured value memory

Up to 60,000 measured values can be stored in the sensor in a ring memory. Each entry contains date/time as well as the respective measured value. Storable values are for example:

- Distance
- Filling height
- Percentage value
- Lin. percent
- Scaled
- Current value
- Meas. reliability
- Electronics temperature

When the instrument is shipped, the measured value memory is active and stores distance, measurement certainty and electronics temperature every 3 minutes.

The requested values and recording conditions are set via a PC with PACTware/DTM or the control system with EDD. Data are thus read out and also reset.

#### Event memory

Up to 500 events are automatically stored with a time stamp in the sensor (non-deletable). Each entry contains date/time, event type, event description and value. Event types are for example:

- Modification of a parameter
- Switching on and off times
- Status messages (according to NE 107)
- Error messages (according to NE 107)

The data are read out via a PC with PACTware/DTM or the control system with EDD.

#### Echo curve memory

The echo curves are stored with date and time and the corresponding echo data. The memory is divided into two sections:

**Echo curve of the setup:** This is used as reference echo curve for the measurement conditions during setup. Changes in the measurement conditions during operation or buildup on the sensor can thus be recognized. The echo curve of the setup is stored via:

- PC with PACTware/DTM
- Control system with EDD
- Indicating and adjustment module

**Further echo curves:** Up to 10 echo curves can be stored in a ring buffer in this memory section. Further echo curves are stored via:

- PC with PACTware/DTM
- Control system with EDD

### 9.3 Asset Management function

The instrument features self-monitoring and diagnostics according to NE 107 and VDI/VDE 2650. In addition to the status messages in the following tables there are more detailed error messages available under the menu item "Diagnostics" via the indicating and adjustment module, PACTware/DTM and EDD.

#### Status messages

The status messages are classified in the following categories:

- Failure
- Function check
- Out of specification
- Maintenance requirement

and explained by pictographs:

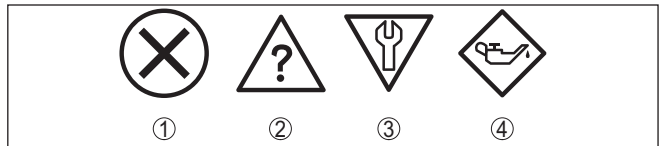

Fig. 42: Pictograms of the status messages

- 1 Failure - red
- 2 Function check - orange
- 3 Out of specification - yellow
- 4 Maintenance - blue

**Failure:** Due to a malfunction in the instrument, a failure message is outputted.

This status message is always active. It cannot be deactivated by the user.

**Function check:** The instrument is in operation, the measured value is temporarily invalid (for example during simulation).

This status message is inactive by default. It can be activated by the user via PACTware/DTM or EDD.

**Out of specification:** The measured value is unstable because the instrument specification is exceeded (e.g. electronics temperature).

This status message is inactive by default. It can be activated by the user via PACTware/DTM or EDD.

**Maintenance:** Due to external influences, the instrument function is limited. The measurement is affected, but the measured value is still valid. Plan in maintenance for the instrument because a failure is expected in the near future (e.g. due to buildup).

This status message is inactive by default. It can be activated by the user via PACTware/DTM or EDD.

## Failure

The following table shows the error codes in the status message "Failure" and gives information on the reason and rectification. Keep in mind that some information is only valid with four-wire instruments.

Code Text message	Cause	Rectification
F013 no measured value available	<ul style="list-style-type: none"> <li>- Sensor does not detect an echo during operation</li> <li>- Antenna system contaminated or defective</li> </ul>	<ul style="list-style-type: none"> <li>- Check or correct installation and/or parameter adjustment</li> <li>- Clean or exchange process component or antenna</li> </ul>
F017 Adjustment span too small	<ul style="list-style-type: none"> <li>- Adjustment not within specification</li> </ul>	<ul style="list-style-type: none"> <li>- Change adjustment according to the limit values (difference between min. and max. <math>\geq 10</math> mm)</li> </ul>
F025 Error in the linearization table	<ul style="list-style-type: none"> <li>- Index markers are not continuously rising, for example unlogical value pairs</li> </ul>	<ul style="list-style-type: none"> <li>- Check linearization table</li> <li>- Delete table/Create new</li> </ul>
F036 No operable software	<ul style="list-style-type: none"> <li>- Failed or interrupted software update</li> </ul>	<ul style="list-style-type: none"> <li>- Repeat software update</li> <li>- Check electronics version</li> <li>- Exchanging the electronics</li> <li>- Send instrument for repair</li> </ul>
F040 Error in the electronics	<ul style="list-style-type: none"> <li>- Hardware defect</li> </ul>	<ul style="list-style-type: none"> <li>- Exchanging the electronics</li> <li>- Send instrument for repair</li> </ul>
F080	<ul style="list-style-type: none"> <li>- General software error</li> </ul>	<ul style="list-style-type: none"> <li>- Separate operating voltage briefly</li> </ul>
F105 Determine measured value	<ul style="list-style-type: none"> <li>- The instrument is still in the start phase, the measured value could not yet be determined</li> </ul>	<ul style="list-style-type: none"> <li>- Wait for the warm-up phase</li> <li>- Duration depending on the version and parameter adjustment up to approximately 3 min.</li> </ul>
F113 Communication error	<ul style="list-style-type: none"> <li>- EMC interferences</li> <li>- Transmission error with the external communication with 4-wire power supply unit</li> </ul>	<ul style="list-style-type: none"> <li>- Remove EMC influences</li> <li>- Exchange 4-wire power supply unit or electronics</li> </ul>
F125 Unpermissible electronics temperature	<ul style="list-style-type: none"> <li>- Temperature of the electronics in the non-specified section</li> </ul>	<ul style="list-style-type: none"> <li>- Check ambient temperature</li> <li>- Isolate electronics</li> <li>- Use instrument with higher temperature range</li> </ul>
F260 Error in the calibration	<ul style="list-style-type: none"> <li>- Error in the calibration carried out in the factory</li> <li>- Error in the EEPROM</li> </ul>	<ul style="list-style-type: none"> <li>- Exchanging the electronics</li> <li>- Send instrument for repair</li> </ul>

Code Text message	Cause	Rectification
F261 Error in the configuration	<ul style="list-style-type: none"> <li>- Error during setup</li> <li>- False signal suppression faulty</li> <li>- Error when carrying out a reset</li> </ul>	<ul style="list-style-type: none"> <li>- Repeat setup</li> <li>- Repeat reset</li> </ul>
F264 Installation/ Setup error	<ul style="list-style-type: none"> <li>- Adjustment not within the vessel height/measuring range</li> <li>- Max. measuring range of the instrument not sufficient</li> </ul>	<ul style="list-style-type: none"> <li>- Check or correct installation and/or parameter adjustment</li> <li>- Use an instrument with bigger measuring range</li> </ul>
F265 Measurement function disturbed	<ul style="list-style-type: none"> <li>- Sensor no longer carries out a measurement</li> <li>- Operating voltage too low</li> </ul>	<ul style="list-style-type: none"> <li>- Check operating voltage</li> <li>- Carry out a reset</li> <li>- Separate operating voltage briefly</li> </ul>

**Function check**

The following table shows the error codes and text messages in the status message "*Function check*" and provides information on causes as well as corrective measures.

Code Text message	Cause	Rectification
C700 Simulation active	<ul style="list-style-type: none"> <li>- A simulation is active</li> </ul>	<ul style="list-style-type: none"> <li>- Finish simulation</li> <li>- Wait for the automatic end after 60 mins.</li> </ul>

**Out of specification**

The following table shows the error codes and text messages in the status message "*Out of specification*" and provides information on causes as well as corrective measures.

Code Text message	Cause	Rectification
S600 Unpermissible electronics temperature	<ul style="list-style-type: none"> <li>- Temperature of the electronics in the non-specified section</li> </ul>	<ul style="list-style-type: none"> <li>- Check ambient temperature</li> <li>- Isolate electronics</li> <li>- Use instrument with higher temperature range</li> </ul>
S601 Overfilling	<ul style="list-style-type: none"> <li>- Danger of vessel overfilling</li> </ul>	<ul style="list-style-type: none"> <li>- Make sure that there is no further filling</li> <li>- Check level in the vessel</li> </ul>

**Maintenance**

The following table shows the error codes and text messages in the status message "*Maintenance*" and provides information on causes as well as corrective measures.

Code Text message	Cause	Rectification
M500 Error with the reset delivery status	– With the reset to delivery status, the data could not be restored	– Repeat reset – Load XML file with sensor data into the sensor
M501 Error in the non-active linearization table	– Hardware error EEPROM	– Exchanging the electronics – Send instrument for repair
M502 Error in the diagnosis memory	– Hardware error EEPROM	– Exchanging the electronics – Send instrument for repair
M503 Reliability too low	– The echo/noise ratio is too small for a reliable measurement	– Check installation and process conditions – Clean the antenna – Change polarisation direction – Use instrument with higher sensitivity
M504 Error on an device interface	– Hardware defect	– Check connections – Exchanging the electronics – Send instrument for repair
M505 No echo available	– Level echo can no longer be detected	– Clean the antenna – Use a more suitable antenna/sensor – Remove possible false echoes – Optimize sensor position and orientation

## 9.4 Rectify faults

### Reaction when malfunctions occur

The operator of the system is responsible for taking suitable measures to rectify faults.

### Procedure for fault rectification

The first measures are:

- Evaluation of fault messages, for example via the indicating and adjustment module
- Checking the output signal with 4 ... 20 mA instruments
- Treatment of measurement errors

Further comprehensive diagnostics options offer a PC with the software PACTware and the suitable DTM. In many cases, the reasons can be determined in this way and faults can be rectified.

### Check the 4 ... 20 mA signal

Connect a handmultimeter in the suitable measuring range according to the wiring plan. The following table describes possible errors in the current signal and helps to remove them:



Error	Cause	Rectification
4 ... 20 mA signal not stable	- Level fluctuations	- Set damping according to the instrument via the indicating and adjustment module or PACTware/DTM
4 ... 20 mA signal missing	- Electrical connection faulty	- Check connection according to chapter "Connection steps" and if necessary, correct according to chapter "Wiring plan".
	- Voltage supply missing	- Check cables for breaks; repair if necessary
	- Operating voltage too low or load resistance too high	- Check, adapt if necessary
Current signal greater than 22 mA or less than 3.6 mA	- Electronics module in the sensor defective	- Exchange the instrument or send it in for repair

**Treatment of measurement errors with bulk solids**

The below tables show typical examples for application-relevant measurement errors with bulk solids. There are two measurement errors:

- Constant level
- Filling
- Emptying

The images in column "Error pattern" show the real level with a broken line and the level displayed by the sensor as a continuous line.

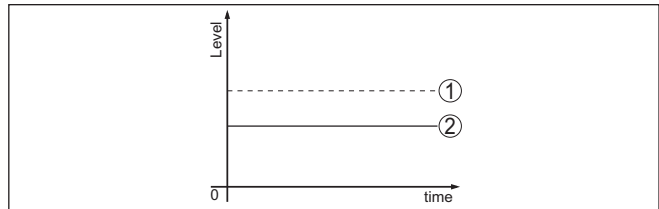

- 1 Real level
- 2 Level displayed by the sensor

Instructions:

- Wherever the sensor displays a constant value, the reason could also be the fault setting of the current output to "Hold value"
- In case of a too low level indication, the reason could be a line resistance that is too high



### 9.4 Measurement error with constant level

Fault description	Error pattern	Cause	Rectification
1. Measured value shows a too low or too high level		- Min./max. adjustment not correct	- Adapt min./max. adjustment
		- Wrong linearization curve	- Adapt linearization curve
2. Measured value jumps towards 100 %		- Due to the process, the amplitude of the product echo sinks - A false signal suppression was not carried out	- Carry out false signal suppression
		- Amplitude or position of a false echo has changed (e.g. condensation, buildup); false signal suppression no longer matches	- Determine the reason for the changed false echo, carry out false signal suppression, e.g. with condensation

### 9.4 Measurement error during filling

Fault description	Error pattern	Cause	Rectification
3rd measured value jumps towards 0 % during filling		- Amplitude of a multiple echo (vessel top - product surface) is larger than the level echo	- Check parameter "Application", especially vessel top, product type, dished end, high dielectric figure, adapt if necessary
		- The level echo cannot be distinguished from the false echo at a false echo position (jumps to multiple echo)	- Remove/reduce false echo: minimize interfering installations by changing the polarization direction - Chose a more suitable installation position
		- Transverse reflection from an extraction funnel, amplitude of the transverse reflection larger than the level echo	- Direct sensor to the opposite funnel wall, avoid crossing with the filling stream
4th measured value fluctuates around 10 ... 20 %		- Various echoes from an uneven product surface, e.g. a material cone	- Check application parameter "Medium type" and adapt, if necessary - Optimize installation position and sensor orientation
		- Reflections from the product surface via the vessel wall (deflection)	- Select a more suitable installation position, optimize sensor orientation, e.g. with a swivelling holder
5. measured value jumps sporadically to 100 % during filling		- Varying condensation or contamination on the antenna	- Carry out a false signal suppression or increase false signal suppression with condensation/contamination in the close range by editing - With bulk solids use radar sensor with purging air connection or flexible antenna cover

### 9.4 Measurement error during emptying

Fault description	Error pattern	Cause	Rectification
6th measured value remains unchanged in the close range during emptying		<ul style="list-style-type: none"> <li>- False echo larger than the level echo</li> <li>- Level echo too small</li> </ul>	<ul style="list-style-type: none"> <li>- Remove false echoes in the close range. Check: Antenna must protrude out of the socket</li> <li>- Remove contamination on the antenna</li> <li>- Minimize interfering installations in the close range by changing the polarization direction</li> <li>- After removing the false echoes, the false signal suppression must be deleted. Carry out a new false signal suppression</li> </ul>
7th measured value jumps sporadically towards 100 % during emptying		<ul style="list-style-type: none"> <li>- Varying condensation or contamination on the antenna</li> </ul>	<ul style="list-style-type: none"> <li>- Carry out false signal suppression or increase false signal suppression in the close range by editing</li> <li>- With bulk solids use radar sensor with purging air connection or flexible antenna cover</li> </ul>
8th measured value fluctuates around 10 ... 20 %		<ul style="list-style-type: none"> <li>- Various echoes from an uneven product surface, e.g. an extraction funnel</li> <li>- Reflections from the product surface via the vessel wall (deflection)</li> </ul>	<ul style="list-style-type: none"> <li>- Check application parameter "Medium type" and adapt, if necessary</li> <li>- Optimize installation position and sensor orientation</li> </ul>

**Reaction after fault rectification**

Depending on the reason for the fault and the measures taken, the steps described in chapter "Setup" must be carried out again or must be checked for plausibility and completeness.

**24 hour service hotline**

Should these measures not be successful, please call in urgent cases the VEGA service hotline under the phone no. **+49 1805 858550**.

The hotline is also available outside the normal working hours on seven days a week around the clock.

Since we offer this service worldwide, the support is in the English language. The service itself is free of charge, the only costs involved are the normal call charges.

### 9.5 Exchanging the electronics module

If the electronics module is defective, it can be replaced by the user.



In Ex applications only one instrument and one electronics module with respective Ex approval may be used.

If there is no electronics module available on site, the electronics module can be ordered through the agency serving you. The electronics modules are adapted to the respective sensor and differ in signal output or voltage supply.

The new electronics module must be loaded with the default settings of the sensor. These are the options:

- In the factory
- Or on site by the user

In both cases, the serial number of the sensor is needed. The serial numbers are stated on the type label of the instrument, on the inside of the housing as well as on the delivery note.

When loading on site, first of all the order data must be downloaded from the Internet (see operating instructions manual "*Electronics module*").

## 9.6 Software update

The following components are required to update the sensor software:

- Sensor
- Voltage supply
- Interface adapter VEGACONNECT 4
- PC with PACTware
- Current sensor software as file

You can find the actual sensor software as well as detailed information of the procedure under "[www.vega.com/downloads](http://www.vega.com/downloads)" and "*Software*".



### Caution:

Instruments with approvals can be bound to certain software versions. Therefore make sure that the approval remains effective with a software update.

You can find detailed information on [www.vega.com/downloads](http://www.vega.com/downloads) and "*Approvals*".

## 9.7 How to proceed in case of repair

You can find a repair form as well as detailed information on how to proceed under [www.vega.com/downloads](http://www.vega.com/downloads) and "*Forms and certificates*".

By doing this you help us carry out the repair quickly and without having to call back for needed information.

If a repair is necessary, please proceed as follows:

- Print and fill out one form per instrument
- Clean the instrument and pack it damage-proof
- Attach the completed form and, if need be, also a safety data sheet outside on the packaging
- Please contact for the return shipment the agency serving you. You can find the agency on our home page [www.vega.com](http://www.vega.com).

## 10 Dismounting

### 10.1 Dismounting steps

**Warning:**

Before dismantling, be aware of dangerous process conditions such as e.g. pressure in the vessel, high temperatures, corrosive or toxic products etc.

Take note of chapters "*Mounting*" and "*Connecting to power supply*" and carry out the listed steps in reverse order.

### 10.2 Disposal

The instrument consists of materials which can be recycled by specialised recycling companies. We use recyclable materials and have designed the electronics to be easily separable.

Correct disposal avoids negative effects on humans and the environment and ensures recycling of useful raw materials.

Materials: see chapter "*Technical data*"

If you have no way to dispose of the old instrument properly, please contact us concerning return and disposal.

**WEEE directive 2002/96/EG**

This instrument is not subject to the WEEE directive 2002/96/EG and the respective national laws. Pass the instrument directly on to a specialised recycling company and do not use the municipal collecting points. These may be used only for privately used products according to the WEEE directive.

## 11 Supplement

### 11.1 Technical data

#### General data

316L corresponds to 1.4404 or 1.4435

#### Materials, wetted parts

- |                        |                                   |
|------------------------|-----------------------------------|
| - Adapter flange       | PP                                |
| - Seal, adapter flange | FKM (COG VI500), EPDM (COG AP310) |
| - Antenna              | PBT-GF 30                         |
| - Focussing lense      | PP                                |

#### Materials, non-wetted parts

- |   |  |
|---|--|
| - Compression flange                            | PP   |
| - Mounting strap                                | 316L   |
| - Fixing screws, mounting strap                 | 316L   |
| - Fixing screws, adapter flange                 | 304  |
| - Plastic housing                               | plastic PBT (Polyester)  |
| - Aluminium die-casting housing                 | Aluminium die-casting AlSi10Mg, powder-coated - basis: Polyester   |
| - Stainless steel housing                       | 316L   |
| - Seal between housing and housing cover        | NBR (stainless steel housing, precision casting), silicone (aluminium/plastic housing; stainless steel housing, electropolished) |
| - Inspection window in housing cover (optional) | Polycarbonate  |
| - Ground terminal                               | 316L   |

#### Process fittings

- |           |   |
|-----------|---|
| - Flanges | DIN from DN 80, ANSI from 3", JIS from DN 100 10K |
|-----------|---|

Weight depending on process fitting and housing material 0.7 ... 3.4 kg (1.543 ... 7.496 lbs)

Max. torque, mounting screws - strap on the sensor housing 4 Nm

#### Max. torque flange screws

- |                            |                     |
|----------------------------|---------------------|
| - Compression flange DN 80 | 5 Nm (3.689 lbf ft) |
| - Adapter flange DN 100    | 7 Nm (5.163 lbf ft) |

#### Max. torque for NPT cable glands and Conduit tubes

- |                                     |                      |
|-------------------------------------|----------------------|
| - Plastic housing                   | 10 Nm (7.376 lbf ft) |
| - Aluminium/Stainless steel housing | 50 Nm (36.88 lbf ft) |

#### Input variable

Measured variable	The measured variable is the distance between the process fitting of the sensor and the product surface. The reference plane is the seal surface of the flange.
-------------------	---

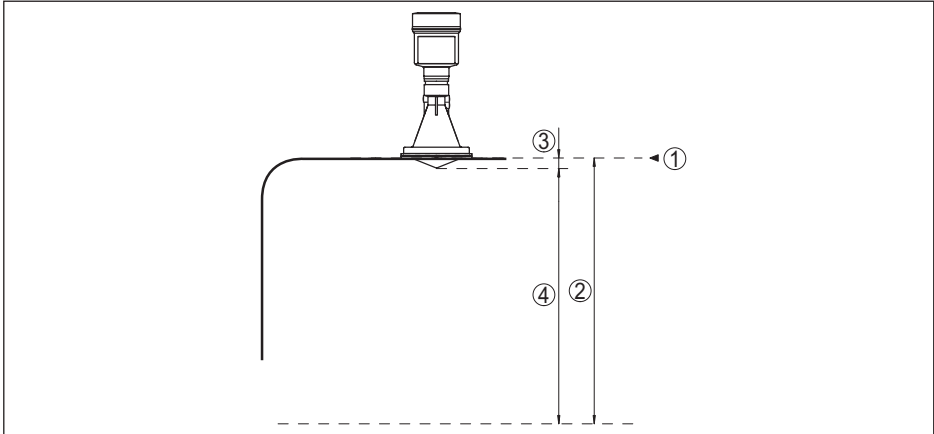

Fig. 52: Data of the input variable

- 1 Reference plane
- 2 Measured variable, max. measuring range
- 3 Antenna length
- 4 Useful measuring range

Max. measuring range	15 m (49.21 ft)
Recommended measuring range	up to 15 m (49.21 ft)

**Output variable**

Output signal	4 ... 20 mA/HART
Fulfilled HART specification	7.0
Signal resolution	0.3 µA
Failure signal current output (adjustable)	mA-value unchanged 20.5 mA, 22 mA, < 3.6 mA
Max. output current	22 mA
Starting current	≤ 3.6 mA; ≤ 10 mA for 5 ms after switching on
Load	see load diagram under Power supply
Damping (63 % of the input variable), adjustable	0 ... 999 s
HART output values according to HART 7.0 <sup>1)</sup>	
- PV (Primary Value)	Distance to the level
- SV (Secondary Value)	Level as percentage value
- TV (Third Value)	Linearised percentage value
- QV (Fourth Value)	Scaled measured value
Resolution, digital	< 1 mm (0.039 in)

**Accuracy (according to DIN EN 60770-1)**

Process reference conditions according to DIN EN 61298-1	
- Temperature	+18 ... +30 °C (+64 ... +86 °F)

<sup>1)</sup> Default values, can be assigned individually

- Relative humidity	45 ... 75 %
- Air pressure	860 ... 1060 mbar/86 ... 106 kPa (12.5 ... 15.4 psig)

## Installation reference conditions

- Min. distance to installations	> 200 mm (7.874 in)
- Reflector	Plane plate reflector
- False reflections	Largest false echo 20 dB smaller than the useful echo

## Deviation with liquids

See following diagrams

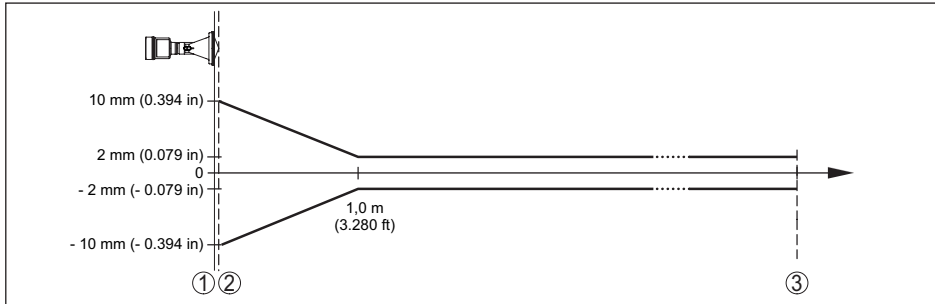

Fig. 53: Deviation under reference conditions

- 1 Reference plane
- 2 Antenna edge
- 3 Recommended measuring range

Reproducibility	$\leq \pm 1$ mm
Deviation with bulk solids	The values depend to a great extent on the application. Binding specifications are thus not possible.
Deviation under EMC influence	$\leq \pm 30$ mm

**Variables influencing measurement accuracy****Specifications apply to the HART signal and the current output**

Temperature drift - Digital output	$\pm 3$ mm/10 K relating to the max. measuring range or max. 10 mm
------------------------------------	--

Additional deviation through strong, high frequency electromagnetic fields acc. to EN 61326  $< \pm 50$  mm

**Specifications apply also to the current output**

Temperature drift - Current output	$\pm 0.03$ %/10 K relating to the 16 mA span max. $\pm 0.3$ %
------------------------------------	---

Deviation on the current output by analogue/digital conversion  $< \pm 15$   $\mu$ A

Deviation on the current output due to strong, high frequency electromagnetic fields acc. to EN 61326  $< \pm 150$   $\mu$ A

**Characteristics and performance data**

Measuring frequency	K-band (26 GHz technology)
Measuring cycle time approx.	700 ms



Step response time <sup>2)</sup>	≤ 3 s
Tracking speed of the measuring window max.	1 m/min
Beam angle <sup>3)</sup>	10°
Emitted HF power (depending on the parameter adjustment) <sup>4)</sup>	
– Average spectral transmission power density	-14 dBm/MHz EIRP
– Max. spectral transmission power density	+43 dBm/50 MHz EIRP
– Max. power density in a distance of 1 m	< 1 μW/cm <sup>2</sup>

---

**Ambient conditions**

Ambient, storage and transport temperature	-40 ... +80 °C (-40 ... +176 °F)
--	----------------------------------

---

**Process conditions**

Process temperature (measured on the process fitting)	-40 ... +80 °C (-40 ... +176 °F)
Vessel pressure	-1 ... 2 bar (-100 ... 200 kPa/-14.5 ... 29.0 psig)
Vessel pressure - version with adapter flange from DN 150 PP	-1 ... 1 bar (-100 ... 100 kPa/-14.5 ... 14.5 psig)
Vibration resistance <sup>5)</sup>	
– Plastic horn antenna with compression or adapter flange	mechanical vibrations up to 2 g in the frequency range 5 ... 200 Hz
– Plastic horn antenna with mounting strap	mechanical vibrations up to 1 g in the frequency range 5 ... 200 Hz

---

**Electromechanical data - version IP 66/IP 67 and IP 66/IP 68; 0.2 bar**

Options of the cable entry

– Cable gland	M20 x 1.5 (cable: ø 5 ... 9 mm)
– Cable entry	½ NPT
– Blind stopper	M20 x 1.5; ½ NPT
– Closing cap	M20 x 1.5; ½ NPT

Plug options

– Signal circuit	M12 x 1, according to ISO 4400, Harting HAN, 7/8" FF
– Indication circuit	M12 x 1

Wire cross-section (spring-loaded terminals)

– Massive wire, cord	0.2 ... 2.5 mm <sup>2</sup> (AWG 24 ... 14)
– Stranded wire with end sleeve	0.2 ... 1.5 mm <sup>2</sup> (AWG 24 ... 16)

<sup>2)</sup> Time span after a sudden measuring distance change by max. 0.5 m in liquid applications, max 2 m with bulk solids applications, until the output signal has taken for the first time 90 % of the final value (IEC 61298-2).

<sup>3)</sup> Outside the specified beam angle, the energy of the radar signal has a level which is reduced by 50 % (-3 dB)

<sup>4)</sup> EIRP: Equivalent Isotropic Radiated Power

<sup>5)</sup> Tested according to the guidelines of German Lloyd, GL directive 2.

**Electromechanical data - version IP 66/IP 68 (1 bar)**

## Options of the cable entry

- Cable gland with integrated connection cable M20 x 1.5 (cable:  $\varnothing$  5 ... 9 mm)
- Cable entry  $\frac{1}{2}$  NPT
- Blind stopper M20 x 1.5;  $\frac{1}{2}$  NPT

## Connection cable

- Wire cross-section 0.5 mm<sup>2</sup> (AWG 20)
- Wire resistance < 0.036  $\Omega$ /m
- Tensile strength < 1200 N (270 lbf)
- Standard length 5 m (16.4 ft)
- Max. length 180 m (590.6 ft)
- Min. bending radius 25 mm (0.984 in) with 25 °C (77 °F)
- Diameter approx. 8 mm (0.315 in)
- Colour - Non-Ex version Blue
- Colour - Ex-version Blue

**Indicating and adjustment module**

- Voltage supply and data transmission through the sensor
- Indication LC display in dot matrix
- Measured value indication
  - Number of digits 5
  - Size of digits W x H = 7 x 13 mm
- Adjustment elements 4 keys
- Protection rating
  - unassembled IP 20
  - mounted into the sensor without cover IP 40
- Materials
  - Housing ABS
  - Inspection window Polyester foil

**Integrated clock**

- Date format Day.Month.Year
- Time format 12 h/24 h
- Time zone Ex factory CET

**Measurement electronics temperature**

- Resolution 1 °C (1.8 °F)
- Accuracy  $\pm 1$  °C (1.8 °F)

**Voltage supply**

- Operating voltage
  - Non-Ex instrument 9.6 ... 36 V DC

- Ex-ia instrument 9.6 ... 30 V DC
- Ex-d-ia instrument 14 ... 36 V DC
- Ex-d-ia instrument with ship approval 15 ... 36 V DC

Operating voltage with illuminated indicating and adjustment module

- Non-Ex instrument 16 ... 36 V DC
- Ex-ia instrument 16 ... 30 V DC
- Ex-d-ia instrument 20 ... 36 V DC

Interpolation protection Integrated

Permissible residual ripple - Non-Ex, Ex-ia instrument

- for  $9.6 \text{ V} < U_N < 14 \text{ V}$   $\leq 0.7 V_{\text{eff}}$  (16 ... 400 Hz)
- for  $18 \text{ V} < U_N < 36 \text{ V}$   $\leq 1.0 V_{\text{eff}}$  (16 ... 400 Hz)

Permissible residual ripple - Ex-d-ia instrument

- for  $18 \text{ V} < U_N < 36 \text{ V}$   $\leq 1 V_{\text{eff}}$  (16 ... 400 Hz)

Load see diagram

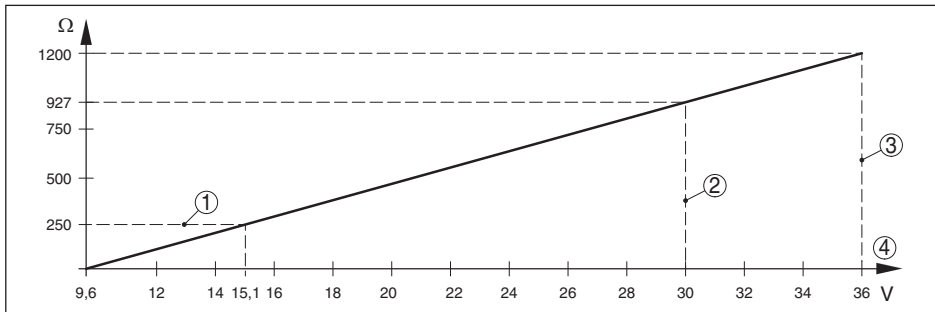

Fig. 54: Voltage diagram

- 1 HART load
- 2 Voltage limit Ex-ia instrument
- 3 Voltage limit non-Ex/Ex-d instrument
- 4 Operating voltage

## Electrical protective measures

Protection, depending on housing version

- Plastic housing IP 66/IP 67
- Aluminium housing, stainless steel housing - investment casting, stainless steel housing - electro-polished IP 66/IP 68 (0.2 bar)<sup>6)</sup>
- Aluminium and stainless housing, investment casting (optionally available) IP 66/IP 68 (1 bar)

Overvoltage category III

Protection class III

<sup>6)</sup> The prerequisites for maintaining the protection rating are a suitable cable as well as correct mounting.

## Approvals

Instruments with approvals can have different technical data depending on the version.

For that reason the associated approval documents of these instruments must be carefully noted. They are part of the delivery or can be downloaded under [www.vega.com](http://www.vega.com) and "VEGA Tools" as well as under "Downloads" and "Approvals".

## 11.2 Dimensions

The following dimensional drawings represent only an extract of all possible versions. Detailed dimensional drawings can be downloaded at [www.vega.com/downloads](http://www.vega.com/downloads) under "Drawings".

### Plastic housing

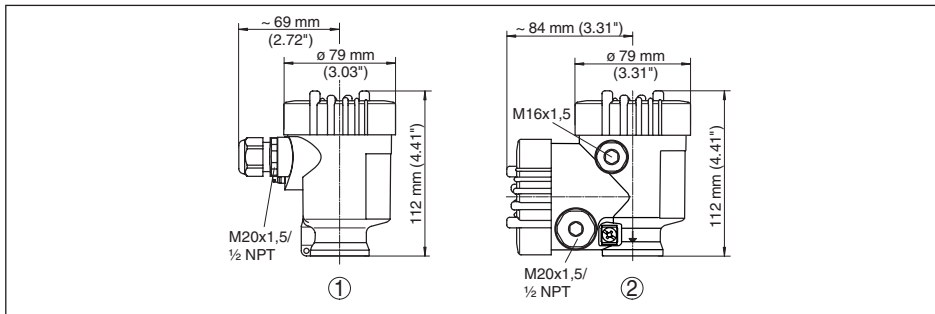

Fig. 55: Housing versions in protection IP 66/IP 68 (0.2 bar) - with integrated indicating and adjustment module the housing is 9 mm/0.35 in higher

- 1 Single chamber version
- 2 Double chamber version

### Aluminium housing

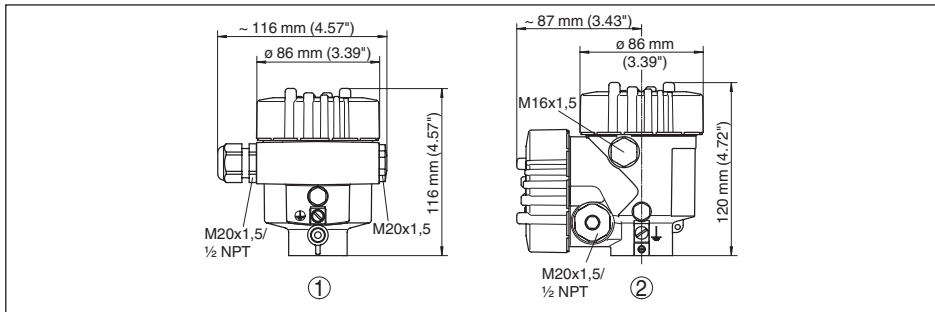

Fig. 56: Housing versions in protection IP 66/IP 68 (0.2 bar) - with integrated indicating and adjustment module the housing is 9 mm/0.35 in higher

- 1 Single chamber version
- 2 Double chamber version

**Aluminium housing in protection rating IP 66/IP 68 (1 bar)**

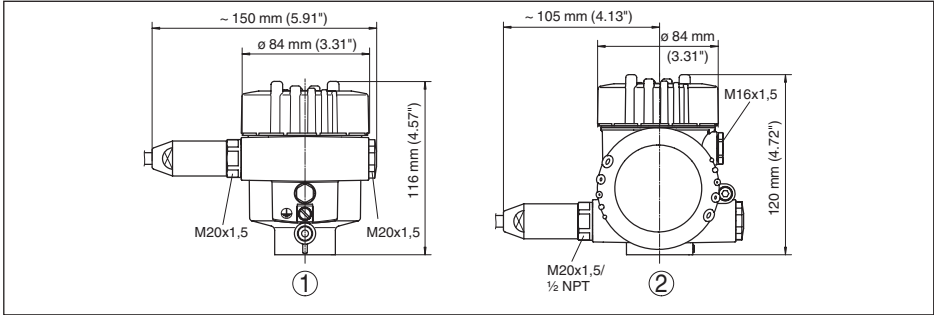

Fig. 57: Housing versions in protection IP 66/IP 68 (1 bar) - with integrated indicating and adjustment module the housing is 9 mm/0.35 in higher

- 1 Single chamber version
- 2 Double chamber version

**Stainless steel housing**

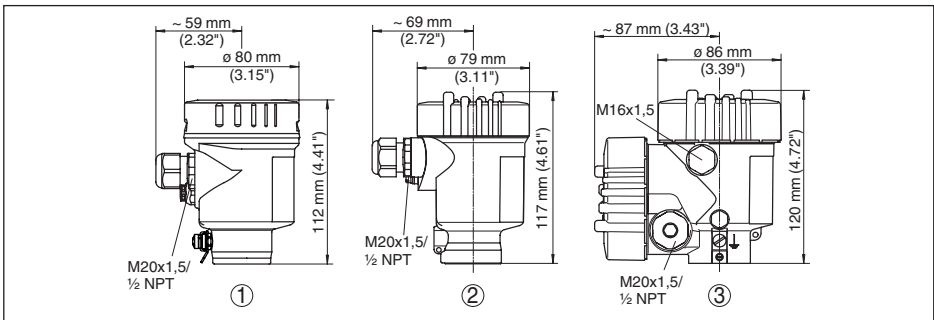

Fig. 58: Housing versions in protection IP 66/IP 68 (0.2 bar) - with integrated indicating and adjustment module the housing is 9 mm/0.35 in higher

- 1 Single chamber version, electropolished
- 2 Single chamber version, precision casting
- 2 Double chamber version, precision casting

### Stainless steel housing in protection rating IP 66/IP 68, 1 bar

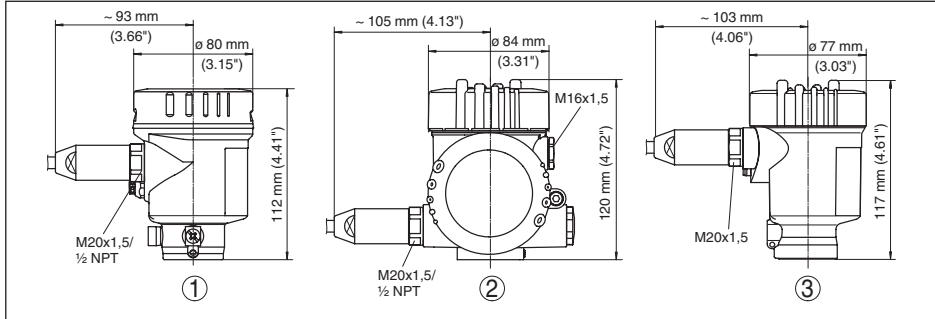

Fig. 59: Housing versions in protection IP 66/IP 68 (1 bar) - with integrated indicating and adjustment module the housing is 9 mm/0.35 in higher

- 1 Single chamber version, electropolished
- 2 Single chamber version, precision casting
- 2 Double chamber version, precision casting

VEGAPULS 67, version with mounting strap

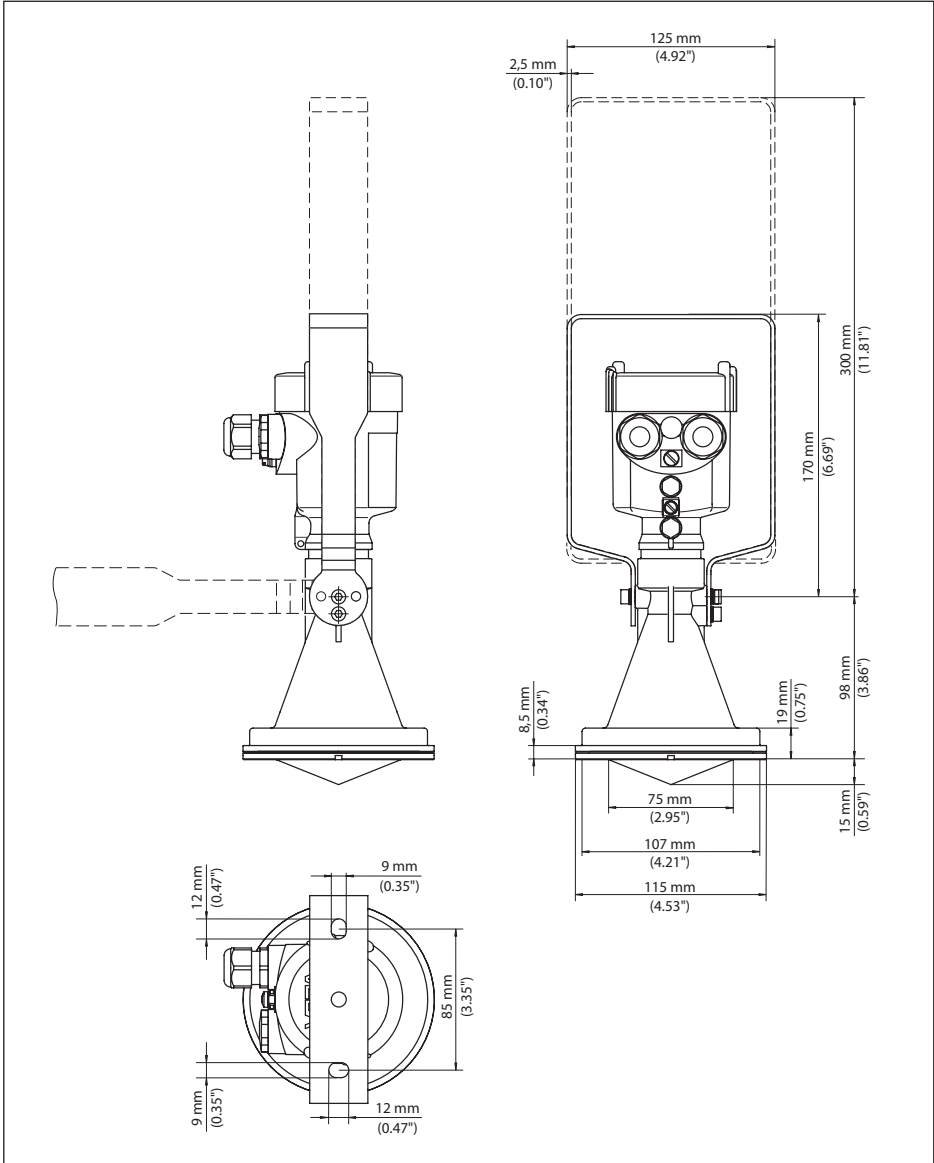

Fig. 60: VEGAPULS 67, mounting strap in 170 or 300 mm length

**VEGAPULS 67, version with compression flange**

Fig. 61: VEGAPULS 67, compression flange suitable for DN 80 PN 16/ASME 3" 150lbs/JIS80 10K



**VEGAPULS 67, version with adapter flange**

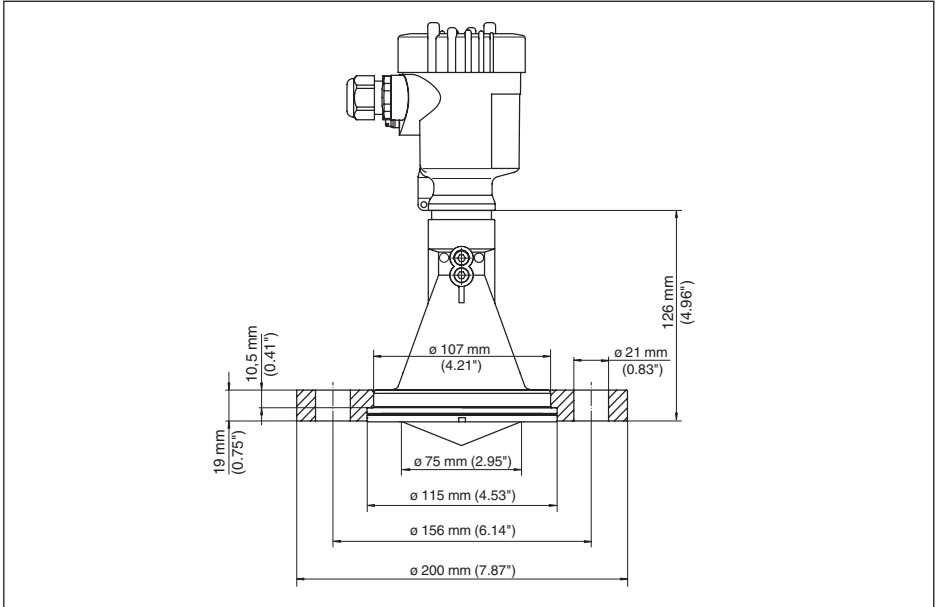
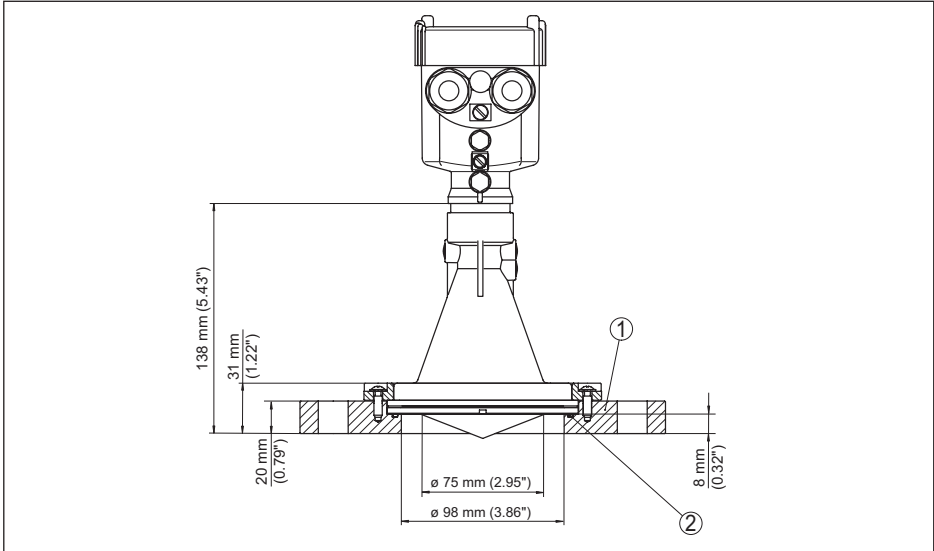

Fig. 62: VEGAPULS 67, adapter flange

- 1 Adapter flange
- 2 Seal

### 11.3 Industrial property rights

VEGA product lines are global protected by industrial property rights. Further information see [www.vega.com](http://www.vega.com).

Only in U.S.A.: Further information see patent label at the sensor housing.

VEGA Produktfamilien sind weltweit geschützt durch gewerbliche Schutzrechte.

Nähere Informationen unter [www.vega.com](http://www.vega.com).

Les lignes de produits VEGA sont globalement protégées par des droits de propriété intellectuelle. Pour plus d'informations, on pourra se référer au site [www.vega.com](http://www.vega.com).

VEGA líneas de productos están protegidas por los derechos en el campo de la propiedad industrial. Para mayor información revise la pagina web [www.vega.com](http://www.vega.com).

Линии продукции фирмы ВЕГА защищаются по всему миру правами на интеллектуальную собственность. Дальнейшую информацию смотрите на сайте [www.vega.com](http://www.vega.com).

VEGA系列产品在全球享有知识产权保护。

进一步信息请参见网站<[www.vega.com](http://www.vega.com)>。

### 11.4 Trademark

All the brands as well as trade and company names used are property of their lawful proprietor/originator.

## INDEX

**A**

- Accessories
  - External indicating and adjustment unit 12
  - External radio unit 12
  - Indicating and adjustment module 12
  - Interface adapter 12
  - Protective cover 12
- Adjustment
  - Max. adjustment 42
  - Min. adjustment 41
- Adjustment system 34
- Agitator 22
- Applications
  - Bulk solid 38
  - Liquid 35
  - Standpipe 36

**C**

- Cable entry 25
- Check signal 56
- Connection cable 25
- Connection procedure 26
- Connection technology 26
- Curve indication
  - Echo curve 43
  - False signal suppression 43

**D**

- DD (Device Description) 51
- Default values 46

**E**

- Echo curve memory 52
- Echo curve of the setup 43
- EDD (Enhanced Device Description) 51
- Electronics and connection compartment, single chamber housing 28
- Electronics compartment, double chamber housing 28
- Electronics compartment with Ex-d double chamber housing 29
- Error messages 53
- Event memory 52

**F**

- False signal suppression 44
- Fault rectification 56
- Functional principle 11

**G**

- Grounding 25, 26

**H**

- HART resistor 48

**K**

- Key function 33

**L**

- Linearisation curve 45

**M**

- Main menu 34
- Meas. reliability 42
- Measured value memory 52
- Measurement error 57
- Medium
  - Liquid Bulk solid 35
- Moisture 14

**N**

- NAMUR NE 107
  - Failure 54
  - Function check 55
  - Maintenance 55
  - Out of specification 55

**O**

- Overflow protection according to WHG 45

**P**

- Packaging 11
- Peak value 42
- Potential equalisation 25, 26

**R**

- Reflection properties 35
- Repair 60
- Replacement parts
  - Electronics module 13
- Reset 45

**S**

- Service hotline 59
- Shielding 25, 26
- Socket 18
- Status messages 53
- Storage 11
- Subsurface enclosure 23

**T**

Type label 10

**V**

Vessel form 40

Vessel height 40

Vessel installations 22

Voltage supply 25







Printing date:

# VEGA

All statements concerning scope of delivery, application, practical use and operating conditions of the sensors and processing systems correspond to the information available at the time of printing.

Subject to change without prior notice

© VEGA Grieshaber KG, Schiltach/Germany 2012



36531-EN-121011

VEGA Grieshaber KG  
Am Hohenstein 113  
77761 Schiltach  
Germany

Phone +49 7836 50-0  
Fax +49 7836 50-201  
E-mail: [info.de@vega.com](mailto:info.de@vega.com)  
[www.vega.com](http://www.vega.com)