



## Product Information

**Guided Wave Radar**  
**Level measurement in bulk solids**  
**VEGAFLEX 82, 86**

# VEGA

### Contents

1	Measuring principle	3
2	Type overview	4
3	Instrument selection	6
4	Selection criteria	8
5	Housing overview	9
6	Mounting	10
7	Electronics - 4 ... 20 mA/HART - two-wire	12
8	Electronics - 4 ... 20 mA/HART - four-wire	13
9	Electronics - Profibus PA	14
10	Electronics - Foundation Fieldbus	15
11	Electronics, Modbus, Levelmaster protocol	16
12	Operation	17
13	Dimensions	18

#### Reading Office

Cutbush Park, Danehill, Lower Earley,  
Reading, Berkshire. RG6 4UT. UK.  
Tel: +44 (0)118 9311188  
Email: info@able.co.uk

#### Aberdeen Office

Unit 6 Airside Business Park, Kirkhill Industrial Estate,  
Dyce, Aberdeen. AB21 0GT. UK.  
Tel: +44 (0)1224 725999  
Email: ab@able.co.uk

Internet: www.able.co.uk  
e-procurement: www.247able.com  
Registered in England No: 01851002  
VAT No: GB 417 2481 61

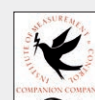

## 1 Measuring principle

### Measuring principle

High frequency microwave pulses are coupled onto a cable or rod and guided along the probe. The pulse is reflected by the product surface. The time from emission to reception of the signals is proportional to the distance of the level.

The instrument is supplied with the probe length (0 % and 100 %) already adjusted. In most cases setup on site is not required. In any case, you set up VEGAFLEX without medium. The shortenable cable and rod versions can be simply adapted to the local requirements, if necessary.

### Applications in bulk solids

Typical process properties in bulk solids are strong dust and noise generation, buildup, condensation and of course the generation of material cones. VEGAFLEX is the ideal measuring system for silos or bunkers with such conditions.

Typical product properties, such as moisture content, mixing ratio or granulate size, do not affect the function of the instrument, which makes planning really simple. The intelligent software guarantees high measurement certainty and a well monitored probe. Even in products with low dielectric constant (from 1.1) the sophisticated processing ensures reliable measuring results.

Different probes are available

- Cable probes - for applications in high vessels up to 75 m (246 ft)
- Rod probes for applications in vessels up to 6 m (20 ft)

### Input variable

The measured quantity is the distance between process fitting of the sensor and product surface. Depending on the sensor version, the reference plane is the seal surface on the hexagon or the lower side of the flange.

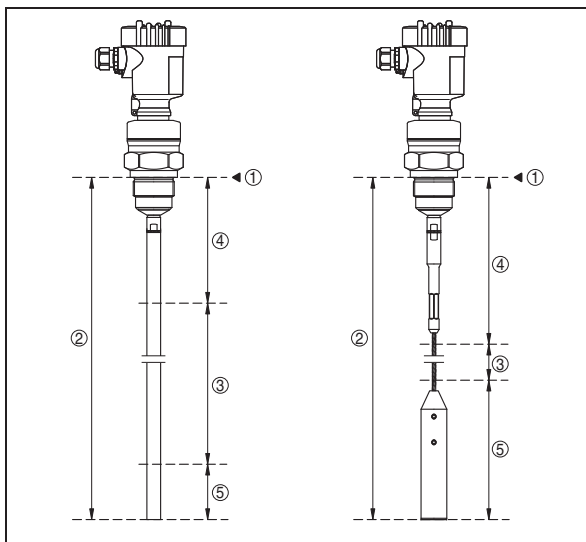

Fig. 1: Measuring ranges of VEGAFLEX

- 1 Reference plane
- 2 Probe length L
- 3 Measuring range
- 4 Upper dead zone (dead band)
- 5 Lower dead zone

### 2 Type overview

**VEGAFLEX 82**  
Cable version



**VEGAFLEX 82**  
Rod version



<b>Applications</b>	High storage silos, silos with product movement	Storage silos
<b>Max. measuring range</b>	75 m (246 ft)	6 m (19.69 ft)
<b>Probe</b>	Cable probe ø 4 mm ø 6 mm ø 11 mm	Rod probe ø 16 mm
<b>Process fitting/Material</b>	Thread from G1½; 1½ NPT, flanges from DN 50, 2"	Thread from G1½; 1½ NPT, flanges from DN 50, 2"
<b>Process temperature</b>	-40 ... +200 °C (-40 ... +392 °F)	-40 ... +200 °C (-40 ... +392 °F)
<b>Process pressure</b>	-1 ... +40 bar/-100 ... +4000 kPa (-14.5 ... +580 psi)	-1 ... +40 bar/-100 ... +4000 kPa (-14.5 ... +580 psi)
<b>Deviation</b>	±2 mm	±2 mm
<b>Signal output</b>	<ul style="list-style-type: none"> <li>• 4 ... 20 mA/HART two-wire</li> <li>• 4 ... 20 mA/HART - four-wire</li> <li>• Profibus PA</li> <li>• Foundation Fieldbus</li> <li>• Modbus, Levelmaster protocol</li> </ul>	
<b>Indication/Adjustment</b>	<ul style="list-style-type: none"> <li>• PLICSCOM</li> <li>• PACTware</li> <li>• VEGADIS 62</li> <li>• VEGADIS 81</li> </ul>	
<b>Approvals</b>	<ul style="list-style-type: none"> <li>• ATEX</li> <li>• IEC</li> <li>• Shipbuilding</li> <li>• FM</li> <li>• CSA</li> <li>• Gost</li> </ul>	

**VEGAFLEX 86**  
Cable version



**VEGAFLEX 86**  
Rod version



<b>Applications</b>	High temperature applications	High temperature applications
<b>Max. measuring range</b>	75 m (246 ft)	6 m (19.69 ft)
<b>Probe</b>	Cable probe ø 2 mm ø 4 mm	Rod probe ø 16 mm
<b>Process fitting/Material</b>	Thread from G1½; 1½ NPT, flanges from DN 50, 2"	Thread from G1½; 1½ NPT, flanges from DN 50, 2"
<b>Process temperature</b>	-196 ... +450 °C (-320 ... +842 °F)	-196 ... +450 °C (-320 ... +842 °F)
<b>Process pressure</b>	-1 ... +400 bar/-100 ... +40000 kPa (-14.5 ... +5800 psi)	-1 ... +400 bar/-100 ... +40000 kPa (-14.5 ... +5800 psi)
<b>Deviation</b>	±2 mm	±2 mm
<b>Signal output</b>	<ul style="list-style-type: none"> <li>• 4 ... 20 mA/HART two-wire</li> <li>• 4 ... 20 mA/HART - four-wire</li> <li>• Profibus PA</li> <li>• Foundation Fieldbus</li> <li>• Modbus, Levelmaster protocol</li> </ul>	
<b>Indication/Adjustment</b>	<ul style="list-style-type: none"> <li>• PLICSCOM</li> <li>• PACTware</li> <li>• VEGADIS 62</li> <li>• VEGADIS 81</li> </ul>	
<b>Approvals</b>	<ul style="list-style-type: none"> <li>• ATEX</li> <li>• IEC</li> <li>• Shipbuilding</li> <li>• FM</li> <li>• CSA</li> <li>• Gost</li> </ul>	

### 3 Instrument selection

#### Application areas

##### VEGAFLEX 82

VEGAFLEX 82 allows maintenance-free measurement of light and heavy bulk solids. Even in applications with strong dust generation, condensation or buildup, the sensor delivers precise and reliable measured values. Automatic probe end tracking enables measurement of virtually any kind of bulk solid material.

##### VEGAFLEX 86

VEGAFLEX 86 is especially suitable for high-temperature applications in all kinds of bulk solids. Even in applications with strong dust generation, condensation or buildup the sensor delivers precise and reliable measured values. Many application possibilities can be found in primary industries, e.g. in cement production.

#### Advantages

##### Immune to dust and vapour

Process conditions such as extreme dust and noise generation do not influence the accuracy of the measurement.

##### Unaffected by material fluctuations

Density fluctuations, different granulate sizes or also fluidizing do not influence the accuracy. Even the change from dry to wet gravel has no effect.

##### Buildup: no problem

Stong buildup on the probe or vessel wall does not influence the measurement result.

##### Wide application range

With measuring ranges up to 75 m the sensors are also suitable for high vessels. Temperature range from -196 °C up to +450 °C and pressures from vacuum up to 400 bar cover a wide application spectrum.

#### Applications

##### Level measurement in conical vessels

During operation, the probe must not touch any installations or the vessel wall. If necessary, fasten the probe end.

In vessels with conical bottom it can be advantageous to mount the sensor in the center of the vessel, as measurement is then possible down to the lowest point of the vessel bottom.

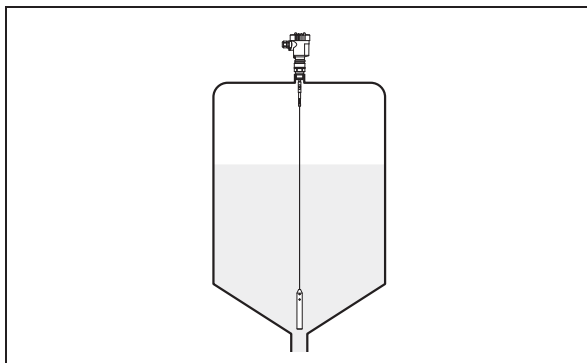

Fig. 3: Vessel with conical bottom

##### Installation position

Mount VEGAFLEX so that the probe does not touch any installations or

When mounting the cable and rod versions of VEGAFLEX, keep a distance of at least 300 mm (11.81 in) to other vessel installations or to the vessel wall.

If possible, mount the sensor flush with the vessel top. If this is not possible, use short sockets with small diameter.

In case of unfavourable mounting conditions such as e.g. very high ( $h > 200$  mm/7.9 in) or very wide ( $\phi > 200$  mm/7.9 in) sockets or an insufficient distance to the vessel wall or vessel installations ( $< 300$  mm/11.81 in), we recommend carrying out a false echo suppression for the area in question. Use the adjustment software PACTware with DTM.

##### Inflowing medium

Make sure that the probe is not subjected to strong lateral forces. Mount VEGAFLEX at a position in the vessel where no mechanical disturbances, e.g. from filling openings, agitators, etc., can occur.

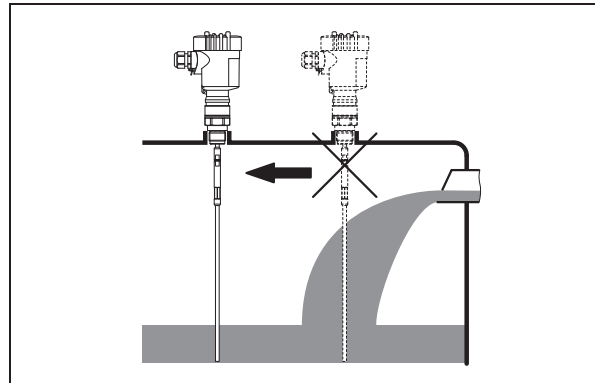

Fig. 4: Lateral load

##### Socket

If possible, avoid sockets. Mount the sensor flush with the vessel top. If this is not possible, use short sockets with small diameter.

Higher sockets or sockets with a bigger diameter can generally be used. They can, however, increase the upper blocking distance (dead band). Check if this is relevant for your measurement.

In such cases, always carry out a false signal suppression after installation. You can find further information under "Setup procedure".

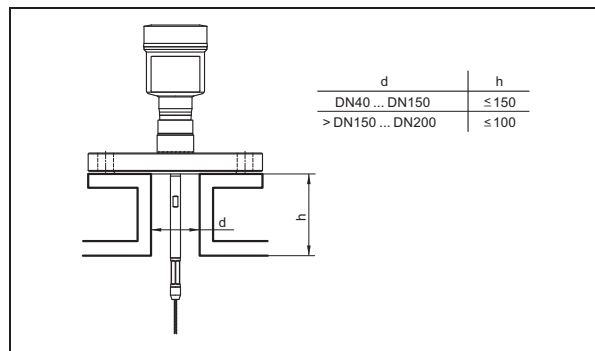

Fig. 5: Mounting socket

When welding the socket, make sure that the socket is flush with the vessel top.

#### Reading Office

Cutbush Park, Danehill, Lower Earley,  
Reading, Berkshire. RG6 4UT. UK.  
Tel: +44 (0)118 9311188  
Email: info@able.co.uk

#### Aberdeen Office

Unit 6 Airside Business Park, Kirkhill Industrial Estate,  
Dyce, Aberdeen. AB21 0GT. UK.  
Tel: +44 (0)1224 725999  
Email: ab@able.co.uk

Internet: www.able.co.uk  
e-procurement: www.247able.com  
Registered in England No: 01851002  
VAT No: GB 417 2481 61



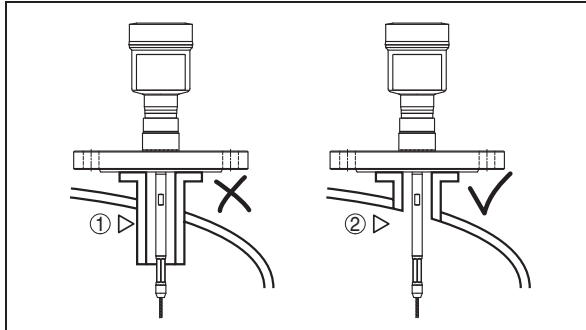

Fig. 6: Socket must be installed flush

- 1 Unfavourable installation
- 2 Socket flush - optimum installation

### Type of vessel

#### Plastic vessel

The guided microwave principle requires a metallic surface on the process fitting. Therefore, in plastic vessels, etc., use an instrument version with flange (from DN 50) or place a metal sheet ( $\varnothing > 200$  mm/8 in) beneath the process fitting when screwing it in.

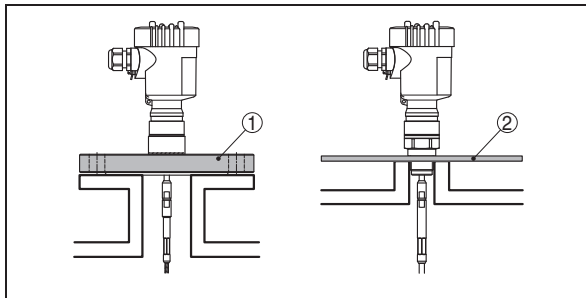

Fig. 7: Installation in plastic silo

- 1 Flange
- 2 Metal plate

#### Concrete vessel

When installed in thick concrete ceilings, VEGAFLEX should be mounted front flush to the lower edge. In concrete silos, the distance to the wall should be at least 500 mm (20 in).

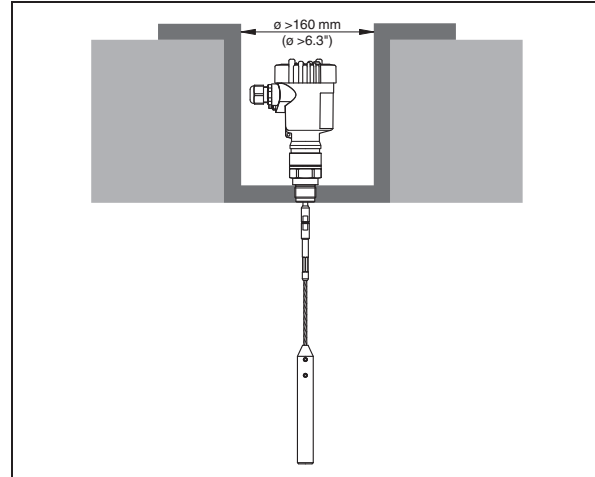

Fig. 8: Installation in concrete silo

#### Reading Office

Cutbush Park, Danehill, Lower Earley,  
Reading, Berkshire. RG6 4UT. UK.  
Tel: +44 (0)118 9311188  
Email: info@able.co.uk

#### Aberdeen Office

Unit 6 Airside Business Park, Kirkhill Industrial Estate,  
Dyce, Aberdeen. AB21 0GT. UK.  
Tel: +44 (0)1224 725999  
Email: ab@able.co.uk

Internet: www.able.co.uk  
e-procurement: www.247able.com  
Registered in England No: 01851002  
VAT No: GB 417 2481 61



### 4 Selection criteria

		VEGAFLEX 82	VEGAFLEX 86		
		Cable	Rod	Cable	Rod
<b>Vessel</b>	Vessels < 6 m	●	○	○	○
	High vessels > 6 m	●	-	○	-
<b>Process</b>	Buildup	●	●	●	●
	Dust	●	●	●	●
	Temperatures > 200 °C	-	-	●	●
	Abrasive bulk solids	-	-	-	-
	Strong extraction forces	●	●	-	-
	Tangential filling	○	●	○	●
<b>Process fittings</b>	Threaded fittings	●	●	●	●
	Flange connections	●	●	●	●
<b>Probe</b>	Separable rod	-	●	-	●
	Probe can be shortened	●	●	●	●
<b>Industry</b>	Chemical	●	●	●	●
	Power generation	●	●	●	●
	Foodstuffs	●	●	●	●
	Metal production	○	○	○	○
	Paper	●	●	○	○
	Shipbuilding	●	●	○	○
	Environment and recycling industry	●	●	○	○
	Cement industry	●	●	●	●



- not recommended



○ possible with limitations



● optimum suitability



## 5 Housing overview

<b>Plastic PBT</b>		
<b>Protection rating</b>	IP 66/IP 67	IP 66/IP 67
<b>Version</b>	Single chamber	Double chamber
<b>Application area</b>	Industrial environment	Industrial environment

<b>Aluminium</b>		
<b>Protection rating</b>	IP 66/IP 67, IP 66/IP 68 (1 bar)	IP 66/IP 67, IP 66/IP 68 (1 bar)
<b>Version</b>	Single chamber	Double chamber
<b>Application area</b>	Industrial environment with increased mechanical stress	Industrial environment with increased mechanical stress

<b>Stainless steel 316L</b>			
<b>Protection rating</b>	IP 66/IP 67	IP 66/IP 67, IP 66/IP 68 (1 bar)	IP 66/IP 67, IP 66/IP 68 (1 bar)
<b>Version</b>	Single chamber, electropolished	Single chamber, precision casting	Double chamber, precision casting
<b>Application area</b>	Aggressive environment, food processing, pharmaceutical	Aggressive environment, extreme mechanical stress	Aggressive environment, extreme mechanical stress

### 6 Mounting

#### Mounting examples

The following illustrations show mounting examples and measurement setups.

#### Foodstuffs and animal feed

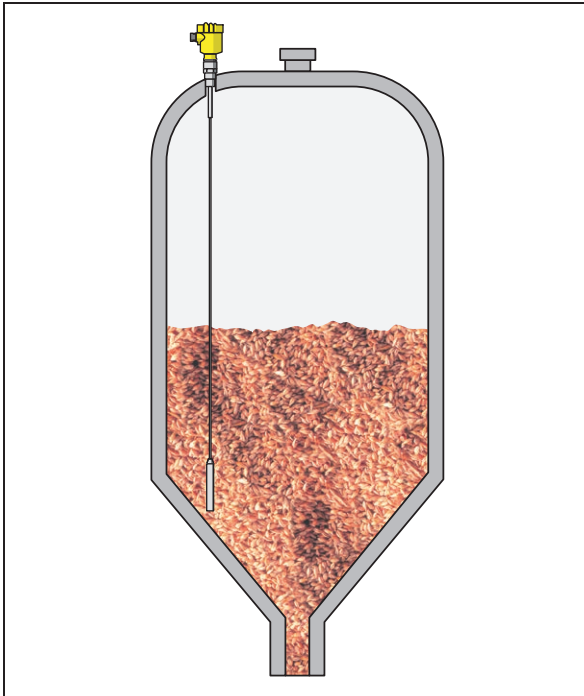

Fig. 9: Level measurement in a grain silo with VEGAFLEX 82

Cereals, sugar, flour, coffee, cornflakes, cacao, instant powder, animal feed - bulk solid levels have to be measured everywhere in the food industry.

The guided microwave principle works independently of product characteristics such as moisture, intense dust or noise generation and the shape of the material cone.

Even very tall silos are no problem. Cable probes, also with PA coating, are available for different loads and in lengths up to 75 m (246 ft).

VEGAFLEX also meets the requirements of dust-Ex Zone 20 (1/2D).

#### Plastics

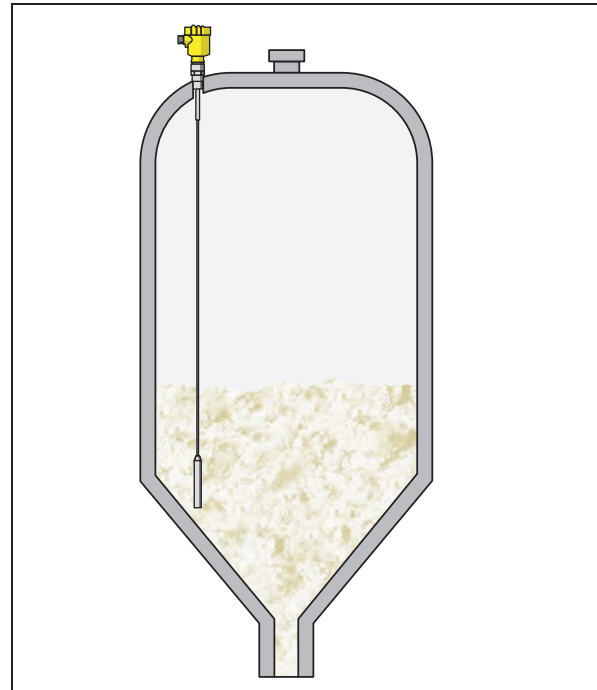

Fig. 10: Level measurement of plastic granules with VEGAFLEX 82

Many finished products in the chemical industry are produced as powder, granules or pellets. The different and sometimes fluctuating product characteristics place heavy demands on the level measurement.

The measuring result is influenced neither by fluctuating product quality nor by dust generation or the shape of the material cone.

Even strong electrostatic discharges cannot harm VEGAFLEX 82.

Unaffected by product properties, the sensor delivers accurate, reproducible level data.

## Building materials

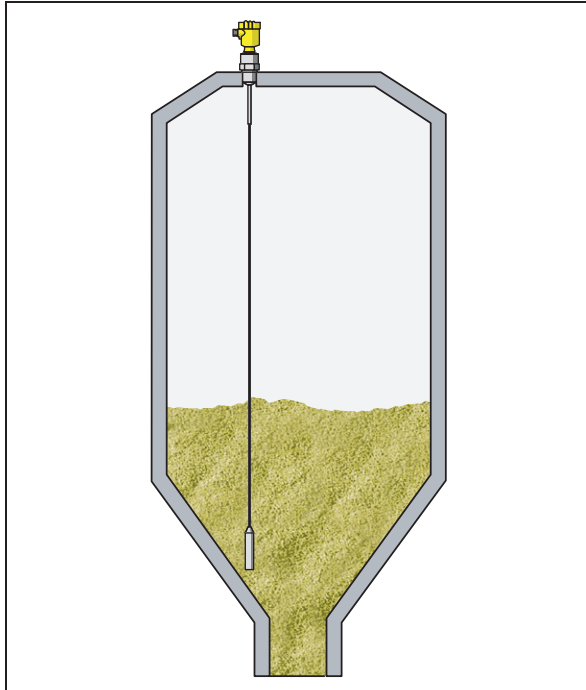

Fig. 11: Level measurement in a storage vessel with VEGAFLEX 82

In the building industry, different additives are stored in single or multiple chamber silos - e.g. cement, sand, filler with varying properties such as moisture content, grain size, material cone shape and flow behavior.

The guided microwave is ideal for level measurement in vessels containing bulk solids. Due to the physical measuring principle, adjustment with medium is no longer necessary. The sensor only has to be electrically connected.

The measuring result is influenced neither by fluctuating product quality nor by dust generation, condensation or the shape of the material cone and therefore has a high reproducibility.

Cable probes are available for different lengths and loads. Tractive forces on the cable up to 3 tons (6000 lbs) are no problem for the stable VEGAFLEX 82.

The measurement is unaffected by product properties such as density, temperature, dielectric constant and buildup. Because it is available in a wide range of versions, VEGAFLEX can even measure products such as light-weight fly ash or hot asphalt.

## Cement

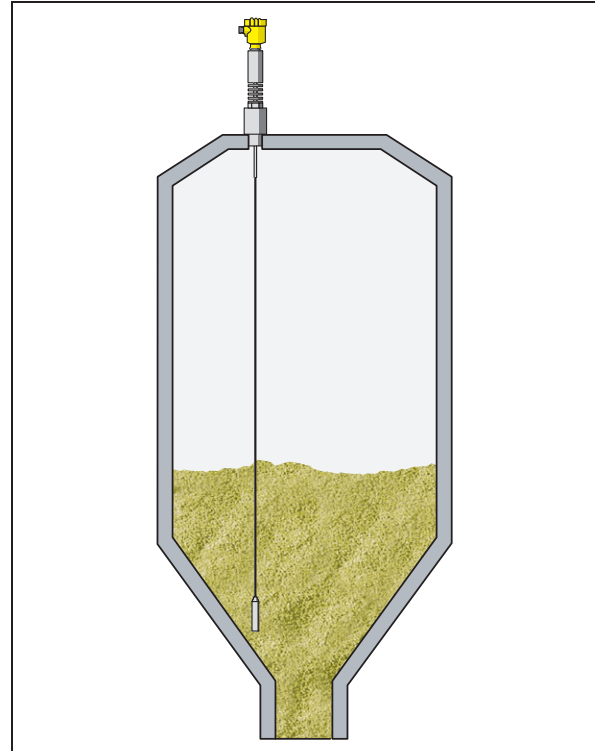

Fig. 12: Level measurement in a clinker vessel with VEGAFLEX 86

In the cement industry, clinker with different consistencies is stored after burning of the raw meal for further processing. Beside the strong dust generation, the high product temperatures and strong abrasion place heavy demands on the measurement technology. Depending on the production capacity of the cement plant, clinker silos can have enormous dimensions, sometimes reaching a height of more than 50 m and a diameter of more than 30 m. They are filled and emptied through different openings.

The guided microwave is ideal for level measurement in vessels containing bulk solids. Due to the physical measuring principle, adjustment with medium is no longer necessary. The sensor only has to be electrically connected.

The measurement is independent of product properties such as density, dielectric constant and buildup. Thanks to its wide range of models, VEGAFLEX can also measure extremely hot products, such as clinker coming directly from the furnace.

### Reading Office

Cutbush Park, Danehill, Lower Earley,  
Reading, Berkshire. RG6 4UT. UK.  
Tel: +44 (0)118 9311188  
Email: info@able.co.uk

### Aberdeen Office

Unit 6 Airside Business Park, Kirkhill Industrial Estate,  
Dyce, Aberdeen. AB21 0GT. UK.  
Tel: +44 (0)1224 725999  
Email: ab@able.co.uk

Internet: www.able.co.uk  
e-procurement: www.247able.com  
Registered in England No: 01851002  
VAT No: GB 417 2481 61



## 7 Electronics - 4 ... 20 mA/HART - two-wire

### Configuration of the electronics

The pluggable electronics is mounted in the electronics compartment of the instrument and can be exchanged by the user when servicing is required. The electronics is completely encapsulated to protect against vibration and moisture.

The terminals for voltage supply as well as the contact pins with I<sup>2</sup>C interface for parameter adjustment are located on the upper side of the electronics. In the double-chamber housing, the terminals are located in the separate terminal compartment.

### Voltage supply

Power supply and current signal are carried on the same two-wire cable. The operating voltage can differ depending on the instrument version.

You can find the data of the voltage supply in chapter "Technical data" in the operating instructions manual of the respective instrument.

Provide a reliable separation between the supply circuit and the mains circuits according to DIN EN 61140 VDE 0140-1.

Data of the voltage supply:

- Operating voltage
  - 9.6 ... 36 V DC
- Permissible residual ripple - Non-Ex, Ex-ia instrument
  - for 9.6 V<sub>< U<sub>N</sub></sub> < 14 V: ≤ 0.7 V<sub>eff</sub> (16 ... 400 Hz)
  - for 18 V<sub>< U<sub>N</sub></sub> < 36 V: ≤ 1.0 V<sub>eff</sub> (16 ... 400 Hz)

Keep in mind the following additional factors that influence the operating voltage:

- Lower output voltage of the power supply unit under nominal load (e.g. with a sensor current of 20.5 mA or 22 mA in case of fault)
- Influence of additional instruments in the circuit (see load values in chapter "Technical data" of the operating instructions of the respective instrument)

### Connection cable

The instrument is connected with standard two-wire cable without screen. If electromagnetic interference is expected which is above the test values of EN 61326-1 for industrial areas, screened cable should be used.

In the product configurator of VEGAFLEX, different cable glands are available. This selection covers all cable diameters in the range of 4 ... 12 mm (0.16 ... 0.47 in).

We generally recommend the use of screened cable for HART multidrop mode.

### Cable screening and grounding

If screened cable is required, we recommend connecting the cable screen on both ends to ground potential. In the sensor, the screen must be connected directly to the internal ground terminal. The ground terminal on the outside of the housing must be connected to the ground potential (low impedance).

### Connection

#### Single chamber housing

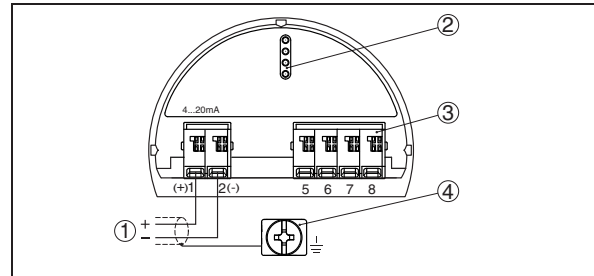

Fig. 13: Electronics and connection compartment, single chamber housing

- 1 Voltage supply/Signal output
- 2 For display and adjustment module or interface adapter
- 3 For external display and adjustment unit
- 4 Ground terminal for connection of the cable screen

#### Double chamber housing

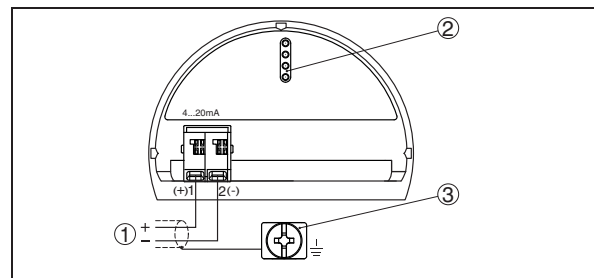

Fig. 14: Terminal compartment, double chamber housing

- 1 Voltage supply/Signal output
- 2 For display and adjustment module or interface adapter
- 3 Ground terminal for connection of the cable screen

#### Wire assignment, connection cable with version IP 66/IP 68, 1 bar

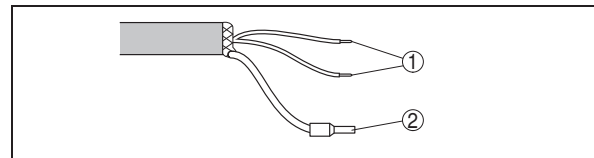

Fig. 15: Wire assignment in permanently connected connection cable

- 1 brown (+) and blue (-) to power supply or to the processing system
- 2 Shielding

## 8 Electronics - 4 ... 20 mA/HART - four-wire

### Configuration of the electronics

The pluggable electronics is mounted in the electronics compartment of the instrument and can be exchanged by the user when servicing is required. The electronics is completely encapsulated to protect against vibration and moisture.

The contact pins with I<sup>2</sup>C interface for parameter adjustment are located on the upper side of the electronics. The terminals for the power supply are located in the separate connection compartment.

### Voltage supply

If a reliable separation is required, the power supply and the current output are transmitted over separate two-wire connection cables.

- Operating voltage with version for low voltage
  - 9.6 ... 48 V DC, 20 ... 42 V AC, 50/60 Hz
- Operating voltage with version for mains voltage
  - 90 ... 253 V AC, 50/60 Hz

### Connection cable

The 4 ... 20 mA current output is connected with standard two-wire cable without screen. If electromagnetic interference is expected which is above the test values of EN 61326 for industrial areas, screened cable should be used.

For power supply, an approved installation cable with PE conductor is required.

An outer cable diameter of 5 ... 9 mm ensures the seal effect of the respective cable entry.

### Cable screening and grounding

If screened cable is required, we recommend connecting the cable screen on both ends to ground potential. In the sensor, the screen must be connected directly to the internal ground terminal. The ground terminal on the outside of the housing must be connected to the ground potential (low impedance).

### Connection, double chamber housing

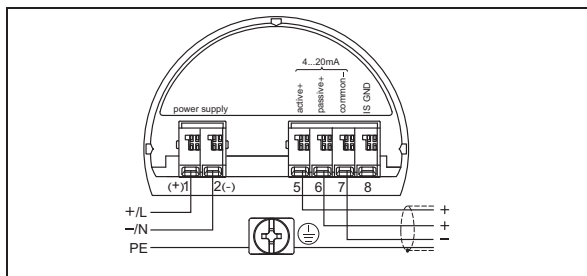

Fig. 16: Terminal compartment, double chamber housing

- 1 Voltage supply
- 2 4 ... 20 mA signal output active
- 3 4 ... 20 mA signal output passive

### 9 Electronics - Profibus PA

#### Configuration of the electronics

The pluggable electronics is mounted in the electronics compartment of the instrument and can be exchanged by the user when servicing is required. The electronics is completely encapsulated to protect against vibration and moisture.

The terminals for voltage supply as well as the plug with I<sup>2</sup>C interface for parameter adjustment are located on the upper side of the electronics. In the double-chamber housing, these connection elements are located in the separate terminal compartment.

#### Voltage supply

The voltage supply is provided by a Profibus DP /PA segment coupler.

Data of the voltage supply:

- Operating voltage
  - 9 ... 32 V DC
- Max. number of sensors per DP/PA segment coupler
  - 32

#### Connection cable

Connection is carried out with screened cable according to Profibus specification.

In the product configurator of VEGAFLEX, different cable glands are available. This selection covers all cable diameters in the range of 4 ... 12 mm (0.16 ... 0.47 in).

Make sure that the entire installation is carried out according to the Profibus specification. In particular, make sure that the bus is terminated with suitable terminating resistors.

#### Cable screening and grounding

In systems with potential equalisation, connect the cable screen directly to ground potential at the power supply unit, in the connection box and at the sensor. The screen in the sensor must be connected directly to the internal ground terminal. The ground terminal outside on the housing must be connected to the potential equalisation (low impedance).

In systems without potential equalisation, connect the cable screen directly to ground potential on the power supply unit and the sensor. In the connection box or T-distributor, the screen of the short stub to the sensor must not be connected to ground potential or to another cable screen.

#### Connection

##### Single chamber housing

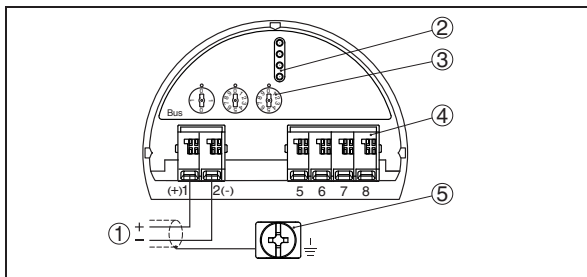

Fig. 17: Electronics and connection compartment, single chamber housing

- 1 Voltage supply/Signal output
- 2 For display and adjustment module or interface adapter
- 3 Selection switch for bus address
- 4 For external display and adjustment unit
- 5 Ground terminal for connection of the cable screen

##### Double chamber housing

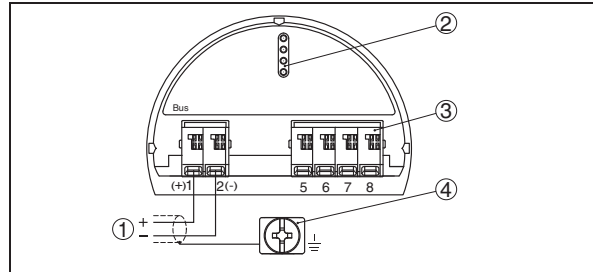

Fig. 18: Terminal compartment, double chamber housing

- 1 Voltage supply/Signal output
- 2 For display and adjustment module or interface adapter
- 3 Ground terminal for connection of the cable screen

##### Wire assignment, connection cable with version IP 66/IP 68, 1 bar

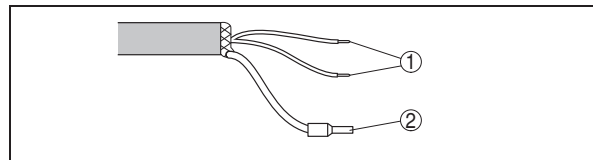

Fig. 19: Wire assignment in permanently connected connection cable

- 1 brown (+) and blue (-) to power supply or to the processing system
- 2 Shielding

#### Reading Office

Cutbush Park, Danehill, Lower Earley,  
Reading, Berkshire. RG6 4UT. UK.  
Tel: +44 (0)118 9311188  
Email: info@able.co.uk

#### Aberdeen Office

Unit 6 Airside Business Park, Kirkhill Industrial Estate,  
Dyce, Aberdeen. AB21 0GT. UK.  
Tel: +44 (0)1224 725999  
Email: ab@able.co.uk

Internet: www.able.co.uk  
e-procurement: www.247able.com  
Registered in England No: 01851002  
VAT No: GB 417 2481 61



## 10 Electronics - Foundation Fieldbus

### Configuration of the electronics

The pluggable electronics is mounted in the electronics compartment of the instrument and can be exchanged by the user when servicing is required. The electronics is completely encapsulated to protect against vibration and moisture.

The terminals for voltage supply as well as the contact pins with I<sup>2</sup>C interface for parameter adjustment are located on the upper side of the electronics. In the double-chamber housing, the terminals are located in the separate terminal compartment.

### Voltage supply

Power supply via the H1 Fieldbus cable.

Data of the voltage supply:

- Operating voltage
  - 9 ... 32 V DC
- max. number of sensors
  - 32

### Connection cable

Connection is carried out with screened cable according to Fieldbus specification.

In the product configurator of VEGAFLEX, different cable glands are available. This selection covers all cable diameters in the range of 4 ... 12 mm (0.16 ... 0.47 in).

Make sure that the entire installation is carried out according to the Fieldbus specification. In particular, make sure that the bus is terminated with suitable terminating resistors.

### Cable screening and grounding

In systems with potential equalisation, connect the cable screen directly to ground potential at the power supply unit, in the connection box and at the sensor. The screen in the sensor must be connected directly to the internal ground terminal. The ground terminal outside on the housing must be connected to the potential equalisation (low impedance).

In systems without potential equalisation, connect the cable screen directly to ground potential on the power supply unit and the sensor. In the connection box or T-distributor, the screen of the short stub to the sensor must not be connected to ground potential or to another cable screen.

### Connection

#### Single chamber housing

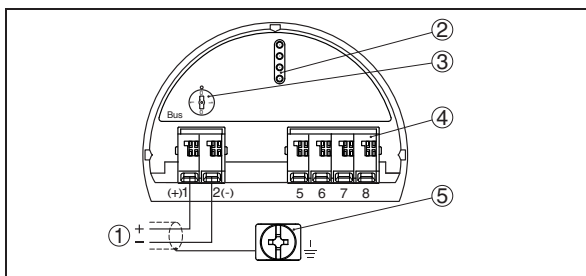

Fig. 20: Electronics and terminal compartment, single chamber housing

- 1 Voltage supply/Signal output
- 2 Contact pins for the display and adjustment module or interface adapter
- 3 Selection switch for bus address
- 4 For external display and adjustment unit
- 5 Ground terminal for connection of the cable screen

#### Double chamber housing

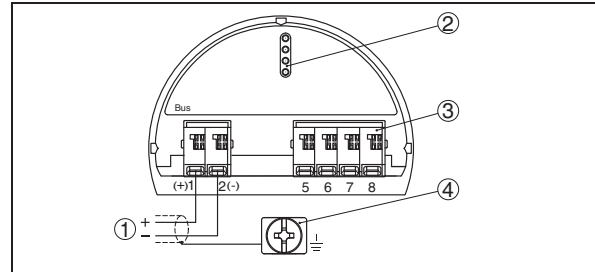

Fig. 21: Terminal compartment, double chamber housing

- 1 Voltage supply/Signal output
- 2 For display and adjustment module or interface adapter
- 3 Ground terminal for connection of the cable screen

#### Wire assignment, connection cable with version IP 66/IP 68, 1 bar

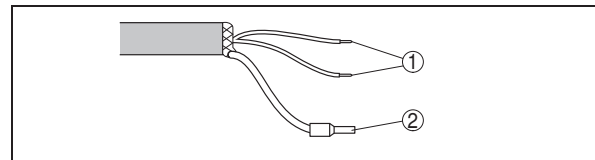

Fig. 22: Wire assignment in permanently connected connection cable

- 1 brown (+) and blue (-) to power supply or to the processing system
- 2 Shielding

#### Reading Office

Cutbush Park, Danehill, Lower Earley,  
Reading, Berkshire. RG6 4UT. UK.  
Tel: +44 (0)118 9311188  
Email: info@able.co.uk

#### Aberdeen Office

Unit 6 Airside Business Park, Kirkhill Industrial Estate,  
Dyce, Aberdeen. AB21 0GT. UK.  
Tel: +44 (0)1224 725999  
Email: ab@able.co.uk

Internet: www.able.co.uk  
e-procurement: www.247able.com  
Registered in England No: 01851002  
VAT No: GB 417 2481 61



## 11 Electronics, Modbus, Levelmaster protocol

### Configuration of the electronics

The pluggable electronics is mounted in the electronics compartment of the instrument and can be exchanged by the user when servicing is required. The electronics is completely encapsulated to protect against vibration and moisture.

The contact pins with I<sup>2</sup>C interface for parameter adjustment are located on the upper side of the electronics. The terminals for the power supply are located in the separate connection compartment.

### Voltage supply

Power supply via the Modbus host (RTU)

- Operating voltage
  - 8 ... 30 V DC
- max. number of sensors
  - 32

### Connection cable

Connection is carried out with screened cable according to Fieldbus specification.

For power supply, a separate two-wire cable is required.

In the product configurator of VEGAFLEX, different cable glands are available. This selection covers all cable diameters in the range of 4 ... 12 mm (0.16 ... 0.47 in).

Make sure that the entire installation is carried out according to the Fieldbus specification. In particular, make sure that the bus is terminated with suitable terminating resistors.

### Cable screening and grounding

In systems with potential equalisation, connect the cable screen directly to ground potential at the power supply unit, in the connection box and at the sensor. The screen in the sensor must be connected directly to the internal ground terminal. The ground terminal outside on the housing must be connected to the potential equalisation (low impedance).

In systems without potential equalisation, connect the cable screen directly to ground potential on the power supply unit and the sensor. In the connection box or T-distributor, the screen of the short stub to the sensor must not be connected to ground potential or to another cable screen.

### Terminal compartment

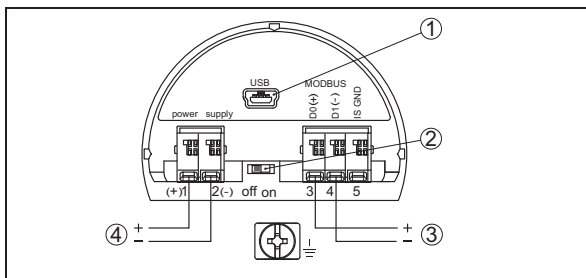

Fig. 23: Terminal compartment

- 1 USB interface
- 2 Slide switch for integrated termination resistor (120 Ω)
- 3 Voltage supply
- 4 Modbus signal

#### Reading Office

Cutbush Park, Danehill, Lower Earley,  
Reading, Berkshire. RG6 4UT. UK.  
Tel: +44 (0)118 9311188  
Email: info@able.co.uk

#### Aberdeen Office

Unit 6 Airside Business Park, Kirkhill Industrial Estate,  
Dyce, Aberdeen. AB21 0GT. UK.  
Tel: +44 (0)1224 725999  
Email: ab@able.co.uk

Internet: www.able.co.uk  
e-procurement: www.247able.com  
Registered in England No: 01851002  
VAT No: GB 417 2481 61





## 12 Operation

### 12.1 Overview

The sensors can be adjusted with the following adjustment media:

- With the display and adjustment module
- With external display and adjustment unit
- an adjustment software according to FDT/DTM standard, e.g. PACTware and PC

as well as via systems from other manufacturers, dependent on the signal output:

- A HART handheld (4 ... 20 mA/HART)
- The adjustment program AMS (4 ... 20 mA/HART and Foundation Fieldbus)
- The adjustment program PDM (Profibus PA)
- A configuration tool (Foundation Fieldbus)

The entered parameters are generally saved in the sensor, optionally also in the display and adjustment module or in the adjustment program.

### 12.2 Display and adjustment module PLICSCOM

The pluggable display and adjustment module is used for measured value indication, operation and diagnosis. It is equipped with an illuminated full dot matrix as well as four keys for adjustment.



Fig. 24: Display and adjustment module PLICSCOM

The display and adjustment module is integrated in the respective sensor housing or in the external indicating and adjustment unit. After mounting, the sensor as well as the display and adjustment module are splash-proof even without housing cover.

### 12.3 External display and adjustment unit VEGADIS 62

VEGADIS 62 is suitable for measured value indication and adjustment of sensors with HART protocol. The instrument is looped into the 4 ... 20 mA/HART signal cable.



Fig. 25: External display and adjustment unit VEGADIS 62

### 12.4 PACTware/DTM

As an alternative to the display and adjustment module, the sensor can also be configured via a Windows PC. To do this, the configuration software PACTware and a suitable instrument driver (DTM) according to the FDT

standard are required. The current PACTware version as well as all available DTMs are compiled in a DTM Collection. The DTMs can also be integrated into other frame applications according to the FDT standard.

All device DTMs are available as a free-of-charge standard version and as a full version that must be purchased. In the standard version, all functions for complete setup are already included. An assistant for simple project configuration simplifies the adjustment considerably. Saving/printing the project as well as import/export functions are also part of the standard version.

In the full version there is also an extended print function for complete project documentation as well as a save function for measured value and echo curves. In addition, there is a tank calculation program as well as a multiviewer for display and analysis of the saved measured value and echo curves.

#### Connection of the PC via VEGACONNECT

The interface converter VEGACONNECT is required for connection of the PC. On the computer side, the connection is made via USB interface. The VEGACONNECT is placed instead of the display and adjustment module to the sensor, the connection to the sensor is made automatically. As an alternative the connection via the HART signal can be carried out on any position of the signal cable with 4 ... 20 mA/HART sensors.

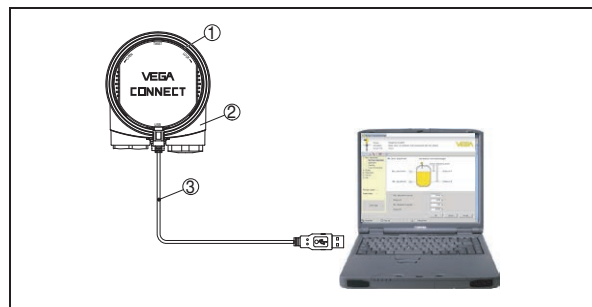

Fig. 26: Connection via VEGACONNECT and USB

- 1 VEGACONNECT
- 2 plics<sup>®</sup> sensor
- 3 USB cable to the PC

Necessary components:

- VEGAFLEX
- PC with PACTware and suitable DTM
- VEGACONNECT
- Voltage supply/Processing system

### 12.5 Alternative adjustment programs

#### PDM

For HART and Profibus PA sensors, device descriptions are available as EDDs for the adjustment program PDM. The device descriptions are already included in the current version of the PDM. Newer instrument drivers that are not yet delivered with the PDM are available in the download section.

#### AMS

For HART and Foundation Fieldbus sensors, device descriptions are available as EDDs for the adjustment program AMS. The device descriptions are already included in the current version of the AMS. Newer instrument drivers that are not yet delivered with the AMS are available in the download section.

### 13 Dimensions

#### Plastic housing

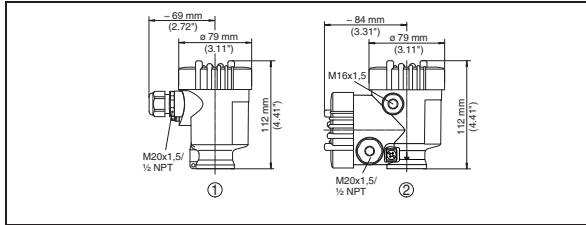

- 1 Single chamber housing
- 2 Double chamber housing

#### Aluminium housing

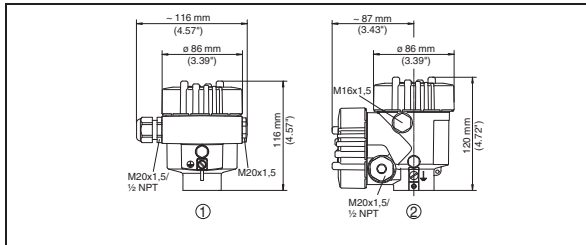

- 1 Single chamber housing
- 2 Double chamber housing

#### Stainless steel housing

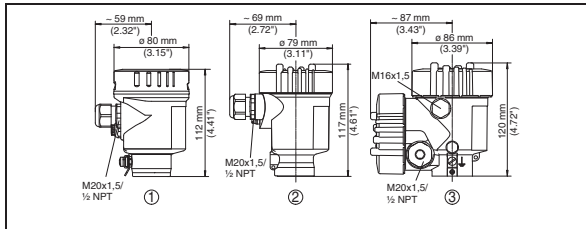

- 1 Single chamber housing, electropolished
- 2 Single chamber housing, precision casting
- 2 Double chamber housing, precision casting

#### VEGAFLEX 82, cable and rod version

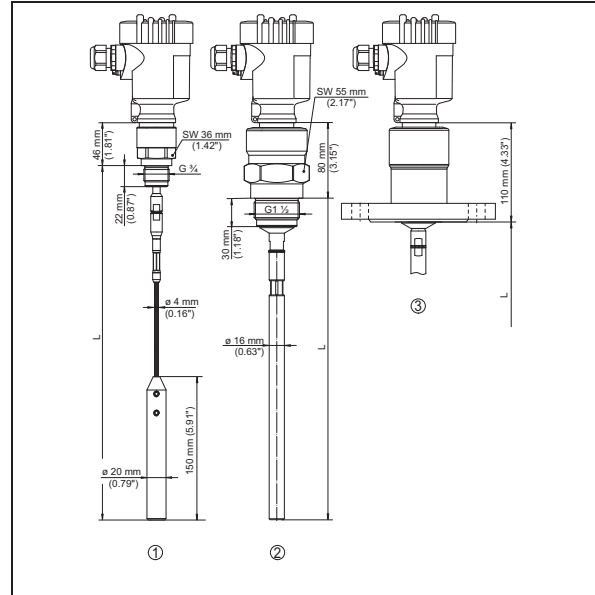

Fig. 27: VEGAFLEX 82, cable and rod version

- 1 Cable version,  $\phi$  4 mm (0.16 in) with threaded fitting
- 2 Rod version,  $\phi$  16 mm (0.63 in) with threaded fitting
- 3 Rod version,  $\phi$  16 mm (0.63 in) with flange connection
- L Sensor length, see chapter "Technical data"

#### VEGAFLEX 86, cable, rod version

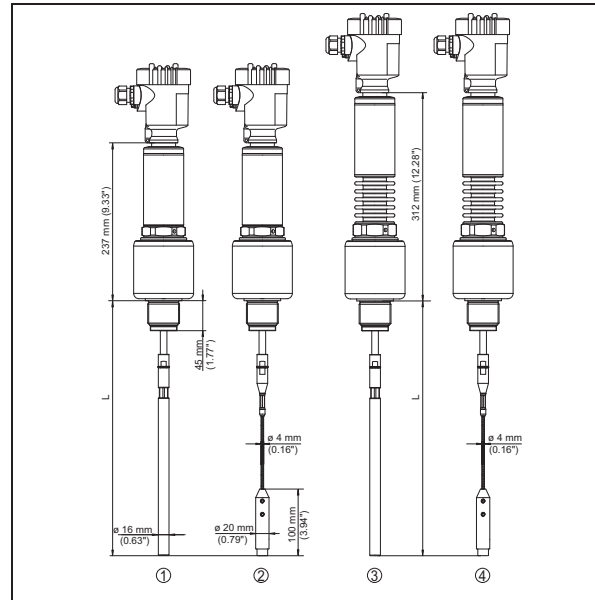

Fig. 29: VEGAFLEX 86, cable, rod version with threaded fitting

- 1 Rod version,  $\phi$  16 mm (0.63 in),  $-20 \dots +250 \text{ }^\circ\text{C}/-4 \dots +482 \text{ }^\circ\text{F}$
- 2 Cable version,  $\phi$  4 mm (0.16 in),  $-20 \dots +250 \text{ }^\circ\text{C}/-4 \dots +482 \text{ }^\circ\text{F}$
- 3 Rod version,  $\phi$  16 mm (0.63 in),  $-200 \dots +400 \text{ }^\circ\text{C}/-328 \dots +752 \text{ }^\circ\text{F}$
- 4 Cable version,  $\phi$  4 mm (0.16 in),  $-200 \dots +400 \text{ }^\circ\text{C}/-328 \dots +752 \text{ }^\circ\text{F}$
- L Sensor length, see chapter "Technical data"