



Product Information

Guided Wave Radar

Level and interface measurement in liquids

VEGAFLEX 81, 83, 86

VEGA

Reading Office

Cutbush Park, Danehill, Lower Earley,
Reading, Berkshire. RG6 4UT. UK.
Tel: +44 (0)118 9311188
Email: info@able.co.uk

Aberdeen Office

Unit 6 Airside Business Park, Kirkhill Industrial Estate,
Dyce, Aberdeen. AB21 0GT. UK.
Tel: +44 (0)1224 725999
Email: ab@able.co.uk

Internet: www.able.co.uk
e-procurement: www.247able.com
Registered in England No: 01851002
VAT No: GB 417 2481 61



Contents

1	Measuring principle	3
2	Type overview	5
3	Instrument selection	8
4	Selection criteria	11
5	Housing overview	12
6	Mounting	13
7	Electronics - 4 ... 20 mA/HART - two-wire	15
8	Electronics - 4 ... 20 mA/HART - four-wire	16
9	Electronics - Profibus PA	17
10	Electronics - Foundation Fieldbus	18
11	Electronics, Modbus, Levelmaster protocol	19
12	Operation	20
13	Dimensions	21

Reading Office

Cutbush Park, Danehill, Lower Earley,
Reading, Berkshire. RG6 4UT. UK.
Tel: +44 (0)118 9311188
Email: info@able.co.uk

Aberdeen Office

Unit 6 Airside Business Park, Kirkhill Industrial Estate,
Dyce, Aberdeen. AB21 0GT. UK.
Tel: +44 (0)1224 725999
Email: ab@able.co.uk

Internet: www.able.co.uk
e-procurement: www.247able.com
Registered in England No: 01851002
VAT No: GB 417 2481 61



1 Measuring principle

Measuring principle

High frequency microwave pulses are coupled onto a cable or rod and guided along the probe. The pulse is reflected by the product surface. The time from emission to reception of the signals is proportional to the distance of the level.

The instrument is supplied with the probe length (0 % and 100 %) already adjusted. In most cases setup on site is not required. In any case, you set up VEGAFLEX without medium. The shortenable, bare cable and rod versions can be simply adapted to the local requirements, if necessary.

Level measurement in liquids

Density fluctuations, steam generation or strong pressure and temperature fluctuations do not influence the measuring result. Also buildup on the probe or the vessel wall do not influence the measurement. This makes VEGAFLEX simple in planning.

An ideal application is level measurement in a bypass tube or standpipe, because even products with a dielectric constant below 1.6 can be reliably measured. Weld seams, buildup and corrosion inside the tube do not influence the accuracy of the level measurement. Even if overfilling up to the process fitting occurs, the measurement is reliable. VEGAFLEX 81 also offers a special solution for ammonia applications.

Different probes are available

- Cable probes - for applications in high vessels up to 75 m (246 ft)
- Rod probes for applications in vessels up to 6 m (20 ft)
- Coax probes for application in low viscosity liquids, with vessel installations, in vessels up to 6 m (20 ft) high

The measured quantity is the distance between process fitting of the sensor and product surface. Depending on the sensor version, the reference plane is the seal surface on the hexagon or the lower side of the flange.

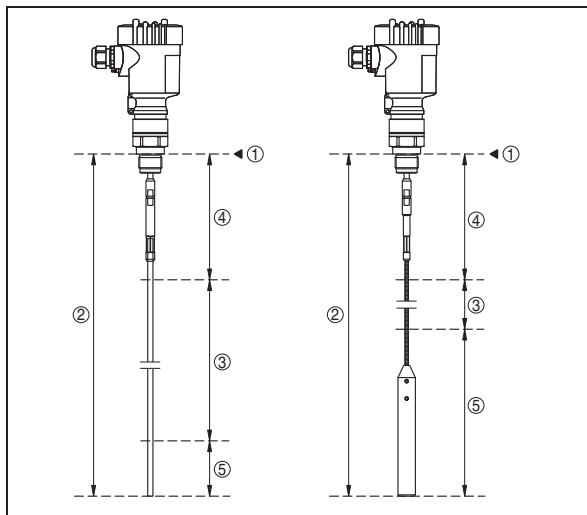

Fig. 1: Measuring ranges of the VEGAFLEX cable and rod versions

- 1 Reference plane
- 2 Probe length L
- 3 Measuring range
- 4 Upper dead zone (dead band)
- 5 Lower dead zone

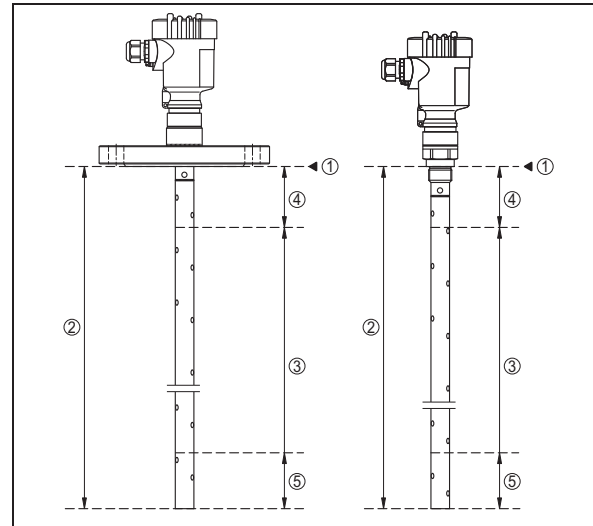

Fig. 3: Measuring ranges of VEGAFLEX - coax version

- 1 Reference plane
- 2 Probe length L
- 3 Measuring range
- 4 Upper dead zone
- 5 Lower dead zone

Interface measurement in liquids

Non-conductive products only partly reflect the energy of microwaves. The non-reflected energy passes through the medium and is reflected at the phase boundary to a second liquid. Interface measurement takes advantage of this effect. You can select this function on VEGAFLEX via the adjustment tools.

You thus get a reliable total level as well as the level of the lower medium in your vessel.

Typical applications are interface measurements in storage tanks, separators and pump sumps. VEGAFLEX normally determines the level of water underneath a non-conductive medium. Since the instrument is independent of the density of the medium, a reliable, maintenance-free and precise measurement can be realised.

By simply switching over, the instruments can be used for interface measurement of liquids.

Thanks to its guide tube, the coax version is not influenced by vessel installations and reliably measures products with low dielectric constant. Therefore this instrument version is preferred.

Prerequisites for interface measurement

Upper medium (L2)

- The upper medium must not be conductive
- The dielectric constant of the upper medium must be known
- The composition of the upper medium must be stable, no varying products or mixtures
- The upper medium must be homogeneous, no stratifications within the medium
- The layer can only be measured if it has a thickness ≥ 100 mm (4 in)
- Clear separation from the lower medium, no emulsion phase, no dextritus layer
- If possible, no foam on the surface

Lower medium (L1)

- The dielectric constant must be 10 higher than the dielectric constant of the upper medium, preferably electrically conductive. Example: upper medium dielectric constant 2, lower medium at least dielectric constant 12

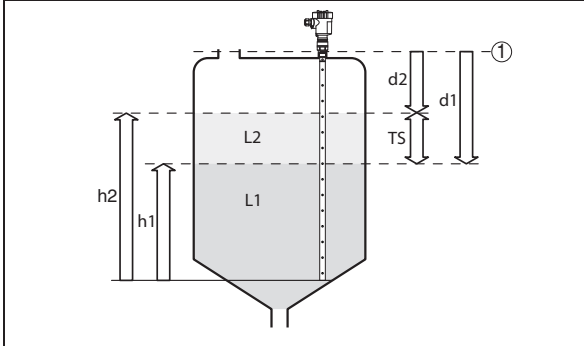

Fig. 5: Interface measurement

- 1 Reference plane
- d1 Distance to the interface (HART value 1 or Primary Value)
- d2 Distance to the level (HART value 3 or Third Value)
- TS Thickness of the upper medium ($d1 - d2$)
- h1 Height - Interface
- h2 Height - Level
- L1 Lower medium
- L2 Upper medium

2 Type overview

VEGAFLEX 81
Cable version



VEGAFLEX 81
Rod version



VEGAFLEX 81
Coax version



Applications	Storage tanks, liquids with agitated surface	Storage tanks, liquids with smooth surface	Storage tanks, liquids with low dielectric constant, vessel with installations
Max. measuring range	75 m (246 ft)	6 m (19.69 ft)	6 m (19.69 ft)
Probe	Cable probe ø 2 mm ø 4 mm	Rod probe ø 8 mm ø 12 mm	Coax probe ø 21.1 mm ø 42.2 mm
Process fitting	Thread from G $\frac{3}{4}$, $\frac{3}{4}$ " NPT or flanges from DN 25, 1"	Thread from G $\frac{3}{4}$, $\frac{3}{4}$ " NPT or flanges from DN 25, 1"	Thread from G $\frac{3}{4}$, $\frac{3}{4}$ " NPT or flanges from DN 25, 1"
Process temperature	-40 ... +200 °C (-40 ... +392 °F)	-40 ... +200 °C (-40 ... +392 °F)	-40 ... +200 °C (-40 ... +392 °F)
Process pressure	-1 ... +40 bar/-100 ... +4000 kPa (-14.5 ... +580 psig)	-1 ... +40 bar/-100 ... +4000 kPa (-14.5 ... +580 psig)	-1 ... +40 bar/-100 ... +4000 kPa (-14.5 ... +580 psig)
Measuring accuracy	±2 mm	±2 mm	±2 mm
Signal output	<ul style="list-style-type: none"> • 4 ... 20 mA/HART two-wire • 4 ... 20 mA/HART - four-wire • Profibus PA • Foundation Fieldbus • Modbus, Levelmaster protocol 		
Indication/Adjustment	<ul style="list-style-type: none"> • PLICSCOM • PACTware • VEGADIS 81 • VEGADIS 62 		
Approvals	<ul style="list-style-type: none"> • ATEX • IEC • Shipbuilding • Overfill protection • FM • CSA • Gost 		

VEGAFLEX 83
Cable version



VEGAFLEX 83
Rod version



VEGAFLEX 83
Rod version - Foodstuffs



Applications	Aggressive and corrosive liquids	Aggressive and corrosive liquids	Hygienic applications in the food processing and pharmaceutical industry
Max. measuring range	32 m (105 ft)	4 m (13.12 ft)	4 m (13.12 ft)
Probe	Cable probe ø 4 mm PFA coated	Rod probe ø 10 mm PFA coated	Rod probe ø 8 mm Polished version (Basle Standard)
Process fitting/Material	Flanges from DN 25, 1" or hygienic connections PTFE-TFM 1600	Flanges from DN 25, 1" or hygienic connections PTFE-TFM 1600	Hygienic fittings
Process temperature	-40 ... +150 °C (-40 ... +392 °F)	-40 ... +150 °C (-40 ... +302 °F)	-20 ... +150 °C (-4 ... +302 °F)
Process pressure	-0.5 ... +16 bar/-50 ... +1600 kPa (-7 ... +232 psig)	-0.5 ... +16 bar/-50 ... +1600 kPa (-7 ... +232 psig)	-1 ... +40 bar/-100 ... +4000 kPa (-14.5 ... +580 psig)
Deviation	±2 mm	±2 mm	±2 mm
Signal output	<ul style="list-style-type: none"> • 4 ... 20 mA/HART two-wire • 4 ... 20 mA/HART - four-wire • Profibus PA • Foundation Fieldbus • Modbus, Levelmaster protocol 		
Indication/Adjustment	<ul style="list-style-type: none"> • PLICSCOM • PACTware • VEGADIS 81 • VEGADIS 62 		
Approvals	<ul style="list-style-type: none"> • ATEX • IEC • Shipbuilding • Overfill protection • FM • CSA • Gost 		

VEGAFLEX 86
Cable version



VEGAFLEX 86
Rod version



VEGAFLEX 86
Coax version



Applications	High temperature applications	High temperature applications	High temperature applications
Max. measuring range	75 m (246 ft)	6 m (19.69 ft)	6 m (19.69 ft)
Probe	Cable probe ø 2 mm ø 4 mm	Rod probe ø 16 mm	Coax probe ø 42.2 mm
Process fitting	Thread G1½ or flanges from DN 40, 2"	Thread G1½ or flanges from DN 40, 2"	Thread G1½ or flanges from DN 40, 2"
Process temperature	-196 ... +450 °C (-321 ... +842 °F)	-196 ... +450 °C (-321 ... +842 °F)	-196 ... +450 °C (-321 ... +842 °F)
Process pressure	-1 ... +400 bar/-100 ... +40000 kPa (-14.5 ... +5800 psig)	-1 ... +400 bar/-100 ... +40000 kPa (-14.5 ... +5800 psig)	-1 ... +400 bar/-100 ... +40000 kPa (-14.5 ... +5800 psig)
Deviation	±2 mm	±2 mm	±2 mm
Signal output	<ul style="list-style-type: none"> • 4 ... 20 mA/HART two-wire • 4 ... 20 mA/HART - four-wire • Profibus PA • Foundation Fieldbus • Modbus, Levelmaster protocol 		
Indication/Adjustment	<ul style="list-style-type: none"> • PLICSCOM • PACTware • VEGADIS 81 • VEGADIS 62 		
Approvals	<ul style="list-style-type: none"> • ATEX • IEC • Shipbuilding • Overfill protection • FM • CSA • Gost 		

3 Instrument selection

Application areas

VEGAFLEX 81

VEGAFLEX 81 is suitable for applications with liquids in small vessels under ordinary process conditions. There are application possibilities in nearly all areas of industry.

Through a large selection of gravity weights, the VEGAFLEX 81 can be also used in standpipes and bypass tubes.

VEGAFLEX 83

The PFA-coated VEGAFLEX 83 is suitable for measurement in aggressive liquids or applications with special hygienic requirements. Application possibilities can be found in the chemical industry as well as in the food processing and pharmaceutical sector.

The polished version of VEGAFLEX 83 is particularly suitable for level measurement under hygienic conditions in, for example, vessels with foodstuffs.

VEGAFLEX 86

VEGAPULS 86 is suitable for high temperature applications in liquids, e.g. in storage tanks and process vessels. The application possibilities can be found in the chemical industry, the environmental and recycling technology as well as in the petrochemical industry.

Applications

Level measurement in conical vessels

During operation, the probe must not touch any installations or the vessel wall. If necessary, fasten the probe end.

In vessels with conical bottom it can be advantageous to mount the sensor in the center of the vessel, as measurement is then possible down to the lowest point of the vessel bottom.

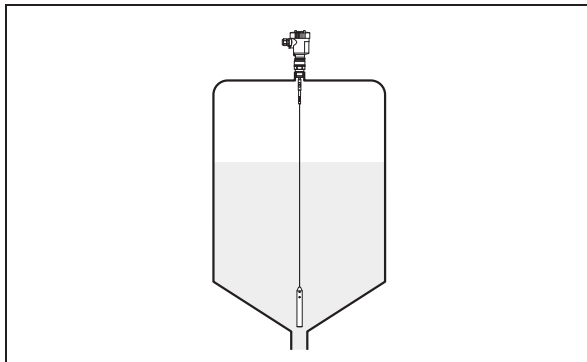

Fig. 6: Vessel with conical bottom

Measurement in a standpipe or bypass tube

When a standpipe or bypass tube is used in a vessel, the influences from vessel installations and turbulence can be excluded. In such case, measurement of products with low dielectric values (ϵ_r value ≥ 1.6) is possible. In very adhesive products, measurement in a standpipe or bypass tube is not recommended.

If VEGAFLEX is used in standpipes or bypass tubes, contact with the tube wall should be avoided. We offer spacers as accessories for fastening the probe in the middle of the tube.

If chemical resistance is not a problem, we recommend using a metal tube to improve measurement reliability.

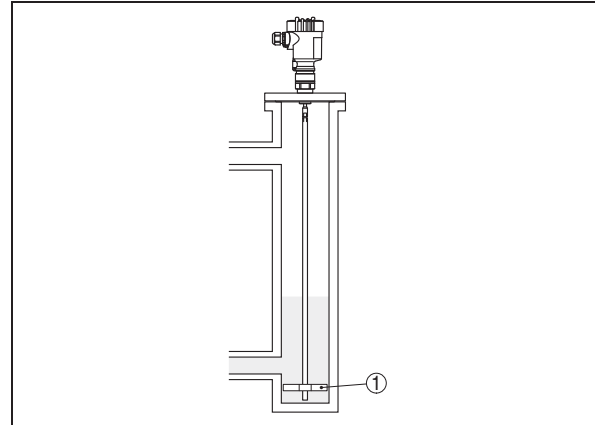

Fig. 7: Position of the spacer

1 Spacer



Note:

Measurement in a standpipe is not recommended for extremely adhesive products.

Interface measurement

Through simple switching, all instruments of the VEGAFLEX 80 series can also measure liquid interfaces. Typical applications are the measurement of oil or solvents on water. The measuring principle is maintenance-free because no moving parts are used. VEGAFLEX operates completely independent of the density of the product. This means reliable measured values without additional effort for correction.

Prerequisites for interface measurement

- The upper medium must not be conductive
- The dielectric constant of the upper medium must be known (input required). Min. dielectric constant: rod version 1.7.
- The composition of the upper medium must be stable, no varying products or mixtures
- The upper medium must be homogeneous, no stratifications within the medium
- Min. thickness of the upper medium 100 mm
- Clear separation to the lower medium, no emulsion phase, no detritus layer
- If possible, no foam on the surface

Lower medium (L1)

- The dielectric constant must be 10 higher than the dielectric constant of the upper medium, preferably electrically conductive. Example: upper medium dielectric constant 2, lower medium at least dielectric constant 12

Reading Office

Cutbush Park, Danehill, Lower Earley,
Reading, Berkshire. RG6 4UT. UK.
Tel: +44 (0)118 9311188
Email: info@able.co.uk

Aberdeen Office

Unit 6 Airside Business Park, Kirkhill Industrial Estate,
Dyce, Aberdeen. AB21 0GT. UK.
Tel: +44 (0)1224 725999
Email: ab@able.co.uk

Internet: www.able.co.uk
e-procurement: www.247able.com
Registered in England No: 01851002
VAT No: GB 417 2481 61



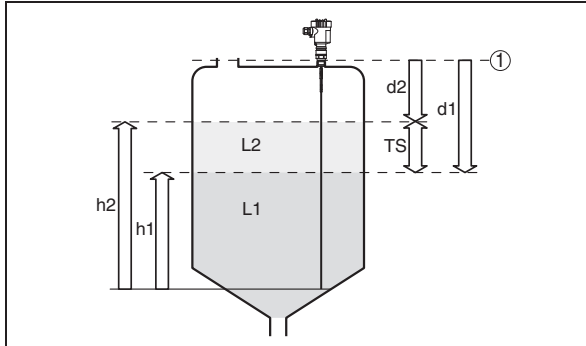

Fig. 8: Interface measurement

- 1 Reference plane
- d1 Distance to the interface (HART value 1)
- d2 Distance to the level (HART value 3)
- TS Thickness of the upper medium (d1 - d2)
- h1 Height - Interface
- h2 Height - Level
- L1 Lower medium
- L2 Upper medium

Socket

If possible, avoid sockets. Mount the sensor flush with the vessel top. If this is not possible, use short sockets with small diameter.

Higher sockets or sockets with a bigger diameter can generally be used. They can, however, increase the upper blocking distance (dead band). Check if this is relevant for your measurement.

In such cases, always carry out a false signal suppression after installation. You can find further information under "Setup procedure".

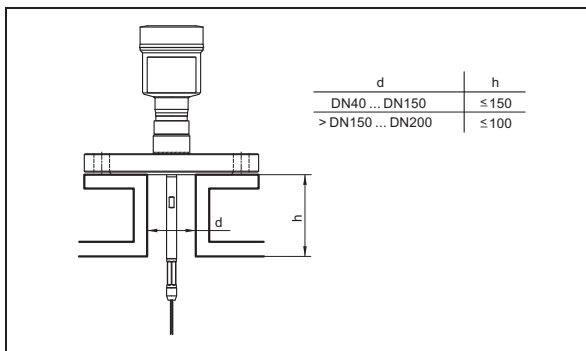

Fig. 9: Mounting socket

When welding the socket, make sure that the socket is flush with the vessel top.

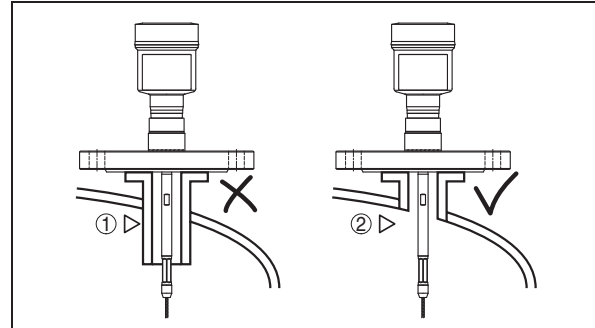

Fig. 10: Socket must be installed flush

- 1 Unfavourable installation
- 2 Socket flush - optimum installation

Plastic vessel/Glass vessel

The guided microwave principle requires a metal surface on the process fitting. Therefore use in plastic vessels etc. an instrument version with flange (from DN 50) or place a metal sheet ($\phi > 200$ mm/8 in) beneath the process fitting when screwing it in.

Make sure that the plate has direct contact with the process fitting.

When installing rod or cable probes in vessels without metal walls, e.g. in plastic vessels, the measured value can be influenced by strong electromagnetic fields (emitted interference according to EN 61326: class A). In this case, use a probe with coaxial version.

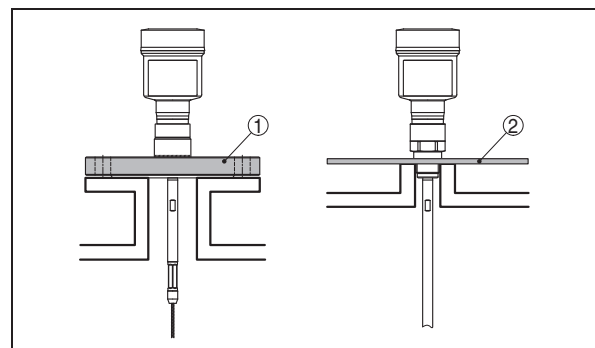

Fig. 11: Installation in non-metallic vessel

- 1 Flange
- 2 Metal sheet

Ammonia applications

For applications in ammonia, a special, gas-tight instrument version of VEGAFLEX 81 as coax probe is available.

For this special application, the instrument is equipped with high resistant seals of elastomer-free materials. The instrument seal and the "Second Line of Defense" are made of borosilicate glass GPC 540.

Steam boiler applications

Vapours, superimposed gases, high pressures and temperature differences can change the spreading speed of radar impulses.

For automatic correction of these deviations, the VEGAFLEX can be optionally equipped with a running time correction over the reference distance. Hence the probe can execute an automatic running time correction.

The reference point must hence not be overfilled. The upper dead band is hence 150 mm (47.7 in).

Reading Office

Cutbush Park, Danehill, Lower Earley,
Reading, Berkshire. RG6 4UT. UK.
Tel: +44 (0)118 9311188
Email: info@able.co.uk

Aberdeen Office

Unit 6 Airside Business Park, Kirkhill Industrial Estate,
Dyce, Aberdeen. AB21 0GT. UK.
Tel: +44 (0)1224 725999
Email: ab@able.co.uk

Internet: www.able.co.uk
e-procurement: www.247able.com
Registered in England No: 01851002
VAT No: GB 417 2481 61



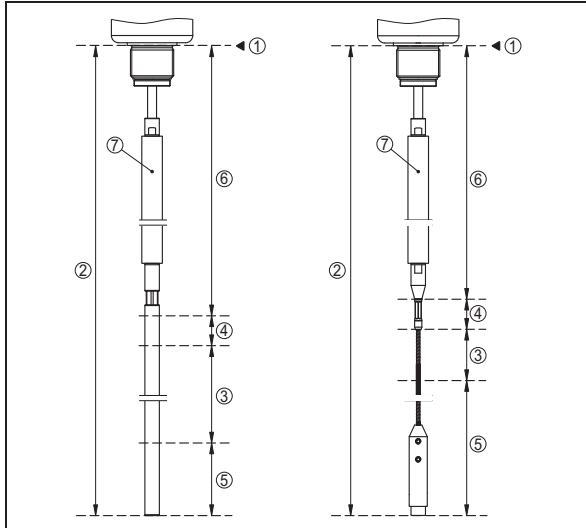

Fig. 12: Measuring ranges - VEGAFLEX with steam compensation

- 1 Reference plane
- 2 Probe length L
- 3 Measuring range
- 4 Upper dead band
- 5 Lower dead band
- 6 Additional upper dead band by steam compensation
- 7 Reference measurement distance to steam compensation

Autoclaved version

For use in an autoclave, e.g. for sterilization, the polished version of VEGAFLEX is available as autoclavable version.

Hence you can separate the housing from the process fitting.

The side of the process fitting is provided with a cover after the housing is removed.

After autoclaving, attach the housing again and the instrument is immediately ready for operation.

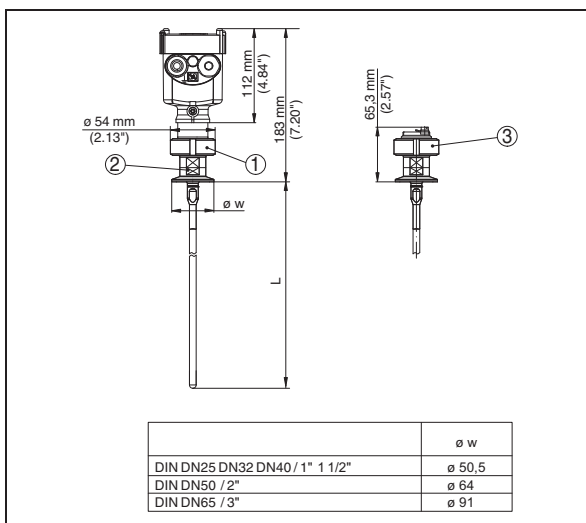

Fig. 14: Autoclaved version

- 1 Groove nut
- 2 Process fitting
- 3 Cover with groove nut

Reading Office

Cutbush Park, Danehill, Lower Earley,
Reading, Berkshire. RG6 4UT. UK.
Tel: +44 (0)118 9311188
Email: info@able.co.uk

Aberdeen Office

Unit 6 Airside Business Park, Kirkhill Industrial Estate,
Dyce, Aberdeen. AB21 0GT. UK.
Tel: +44 (0)1224 725999
Email: ab@able.co.uk

Internet: www.able.co.uk
e-procurement: www.247able.com
Registered in England No: 01851002
VAT No: GB 417 2481 61



4 Selection criteria

● optimum suitability

		VE - GA-FLEX 81	VEGAFLEX 83				VEGAFLEX 86			
		Cable	Rod	Coax	Cable	Rod	Food	Cable	Rod	Coax
Vessel	Vessels < 6 m	●	●	●	●	●	●	●	●	●
	High vessels > 6 m	●	-	-	●	-	-	●	-	-
	Non-metallic vessels	○	○	○	○	○	○	○	○	○
	Measurement in a standpipe or bypass tube	●	●	○	-	○	●	●	●	○
Process	Aggressive liquids	-	-	-	●	●	-	-	-	-
	Bubble or foam generation	●	●	●	●	●	●	●	●	●
	Wave movements at the surface	●	●	●	●	●	●	●	●	●
	Steam or condensation	●	●	●	●	●	●	●	●	●
	Buildup	●	●	-	●	●	●	●	●	-
	Changing density	●	●	●	●	●	●	●	●	●
	Ammonia application	-	-	●	-	-	-	-	-	-
	High temperatures > 200 °C	-	-	-	-	-	-	●	●	●
	Pressures up to 400 bar	-	-	-	-	-	-	●	●	●
	Hygienic applications	-	-	-	○	○	●	-	-	-
	Narrow space above the vessel	●	○	-	●	-	-	●	○	-
Steam boiler application	-	-	-	-	-	-	-	-	●	
Process fitting	Threaded fittings	●	●	●	-	-	-	●	●	●
	Flange connections	●	●	●	●	●	●	●	●	●
	Hygienic fittings	-	-	-	●	●	●	-	-	-
Probe	Stainless steel	●	●	●	-	-	●	●	●	●
	PFA coating	-	-	-	●	●	-	-	-	-
	Polished (Bastle Standard)	-	-	-	-	-	●	-	-	-
	Probe can be shortened	●	●	-	-	-	-	●	●	-
Industry	Chemical	●	●	●	●	●	●	●	●	●
	Power generation	●	●	●	○	○	-	●	●	●
	Foodstuffs	-	-	-	●	●	●	-	-	-
	Offshore	●	●	●	○	○	-	●	●	●
	Petrochemical	●	●	●	○	○	-	●	●	●
	Pharmaceutical	-	-	-	●	●	●	-	-	-
	Shipbuilding	●	○	○	-	-	-	●	○	○
	Environment and recycling industry	●	●	●	●	●	●	●	●	●
	Water	●	●	○	●	●	●	○	○	○
	Waste water	○	○	-	○	○	○	○	○	-

5 Housing overview

Plastic PBT		
Protection rating	IP 66/IP 67	IP 66/IP 67
Version	Single chamber	Double chamber
Application area	Industrial environment	Industrial environment

Aluminium		
Protection rating	IP 66/IP 67, IP 66/IP 68 (1 bar)	IP 66/IP 67, IP 66/IP 68 (1 bar)
Version	Single chamber	Double chamber
Application area	Industrial environment with increased mechanical stress	Industrial environment with increased mechanical stress

Stainless steel 316L			
Protection rating	IP 66/IP 67	IP 66/IP 67, IP 66/IP 68 (1 bar)	IP 66/IP 67, IP 66/IP 68 (1 bar)
Version	Single chamber, electropolished	Single chamber, precision casting	Double chamber, precision casting
Application area	Aggressive environment, food processing, pharmaceutical	Aggressive environment, extreme mechanical stress	Aggressive environment, extreme mechanical stress

6 Mounting

Mounting examples

The following illustrations show mounting examples and measurement setups.

Storage vessels



Fig. 15: Level measurement in a storage vessel with VEGAFLEX 81

The guided microwave principle is ideal for level measurement in storage vessels. The sensor can be set up without filling or adjustment with medium.

Cable and rod probes are available for different lengths and loads.

The coax version is especially suitable for low viscosity liquids with low dielectric constant. This also applies when the requirements on the accuracy of the measurement are very high.

The measurement is independent of product characteristics such as density, temperature, overpressure, foam, dielectric constant and buildup.

Different, as well as frequently changing products and mixtures can be measured.

Tanks with foodstuffs

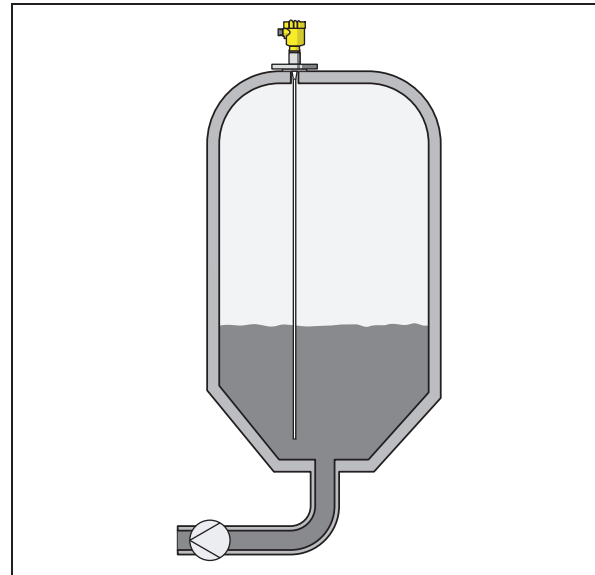

Fig. 16: Level measurement in a vessel with foodstuffs with VEGAFLEX 83

The fully PFA insulated VEGAFLEX 83 is ideal for level measurement in vessels in the food processing and pharmaceutical industries. The sensor can be set up without filling or adjustment with medium. Fully insulated rod probes are available in lengths up to 4 m (13 ft) and cable probes up to 32 m (105 ft).

The wetted parts are made of the food safe plastics PFA and TFM-PTFE.

The measurement is unaffected by product characteristics such as density, temperature or overpressure. Even foam and buildup do not influence the measurement.

Different, as well as frequently changing products and mixtures can be measured.

Bypass tube

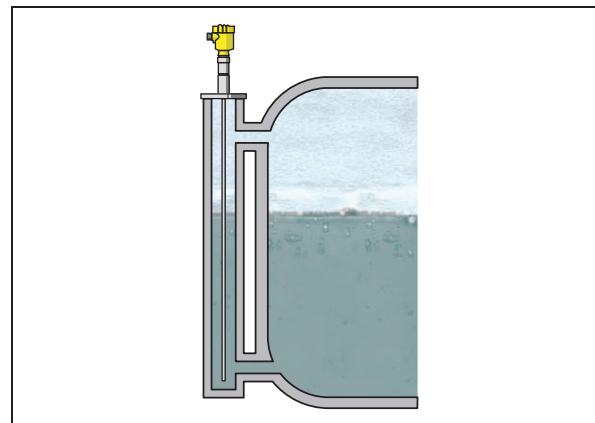

Fig. 17: Level measurement in a bypass tube

Standpipes or bypass tubes are often used in distillation columns, e.g. in the petrochemical industry. Also in this environment, measurement with guided microwaves has many advantages.

The configuration of the standpipe or bypass tube does not influence the measurement. Lateral tube connections, mixing holes, buildup or corrosion in the tube do not influence the measuring result.

Reading Office

Cutbush Park, Danehill, Lower Earley,
Reading, Berkshire. RG6 4UT. UK.
Tel: +44 (0)118 9311188
Email: info@able.co.uk

Aberdeen Office

Unit 6 Airside Business Park, Kirkhill Industrial Estate,
Dyce, Aberdeen. AB21 0GT. UK.
Tel: +44 (0)1224 725999
Email: ab@able.co.uk

Internet: www.able.co.uk
e-procurement: www.247able.com
Registered in England No: 01851002
VAT No: GB 417 2481 61



Product temperatures up to 400 °C (752 °F) can be measured, up to 150 °C (302 °F) even with standard versions.

The sensor utilises nearly the entire vessel height, and can measure with high accuracy up to approx. 30 mm (1.181 in) below the process fitting. A possible overfilling even in this range is detected reliably.

VEGAFLEX sensors are also available with SIL2.

7 Electronics - 4 ... 20 mA/HART - two-wire

Configuration of the electronics

The pluggable electronics is mounted in the electronics compartment of the instrument and can be exchanged by the user when servicing is required. The electronics is completely encapsulated to protect against vibration and moisture.

The terminals for voltage supply as well as the contact pins with I²C interface for parameter adjustment are located on the upper side of the electronics. In the double chamber housing, the terminals are located in the separate terminal compartment.

Voltage supply

Power supply and current signal are carried on the same two-wire cable. The operating voltage can differ depending on the instrument version.

You can find the data of the voltage supply in chapter "Technical data" in the operating instructions manual of the respective instrument.

Provide a reliable separation between the supply circuit and the mains circuits according to DIN EN 61140 VDE 0140-1.

Data of the voltage supply:

- Operating voltage
 - 9.6 ... 36 V DC
- Permissible residual ripple - Non-Ex, Ex-ia instrument
 - for 9.6 V_{< U_N} < 14 V: ≤ 0.7 V_{eff} (16 ... 400 Hz)
 - for 18 V_{< U_N} < 36 V: ≤ 1.0 V_{eff} (16 ... 400 Hz)

Keep in mind the following additional factors that influence the operating voltage:

- Lower output voltage of the power supply unit under nominal load (e.g. with a sensor current of 20.5 mA or 22 mA in case of fault message)
- Influence of additional instruments in the circuit (see load values in chapter "Technical data" of the operating instructions of the respective instrument)

Connection cable

The instrument is connected with standard two-wire cable without screen. If electromagnetic interference is expected which is above the test values of EN 61326-1 for industrial areas, screened cable should be used.

In the product configurator of VEGAFLEX, different cable glands are available. This selection covers all cable diameters in the range of 4 ... 12 mm (0.16 ... 0.47 in).

We generally recommend the use of screened cable for HART multidrop mode.

Cable screening and grounding

If screened cable is required, we recommend connecting the cable screen on both ends to ground potential. In the sensor, the screen must be connected directly to the internal ground terminal. The ground terminal on the outside of the housing must be connected to the ground potential (low impedance).

Connection

Single chamber housing

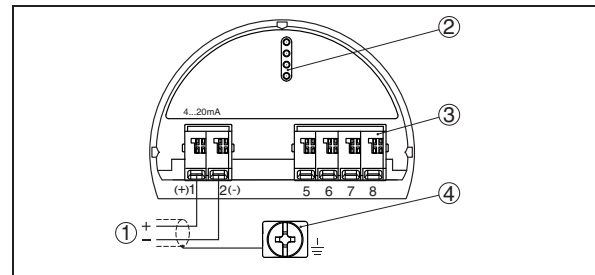

Fig. 18: Electronics and connection compartment, single chamber housing

- 1 Voltage supply/Signal output
- 2 For display and adjustment module or interface adapter
- 3 For external display and adjustment unit
- 4 Ground terminal for connection of the cable screen

Double chamber housing

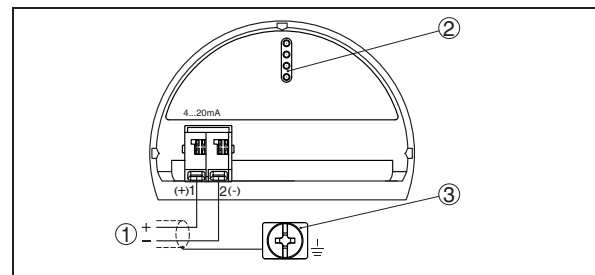

Fig. 19: Connection compartment, double chamber housing

- 1 Voltage supply/Signal output
- 2 For display and adjustment module or interface adapter
- 3 Ground terminal for connection of the cable screen

Wire assignment, connection cable with version IP 66/IP 68, 1 bar

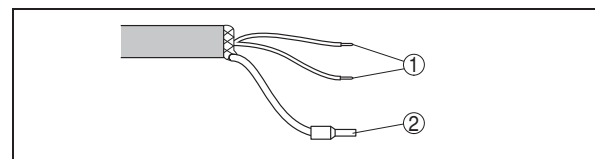

Fig. 20: Wire assignment fix-connected connection cable

- 1 brown (+) and blue (-) to power supply or to the processing system
- 2 Shielding

8 Electronics - 4 ... 20 mA/HART - four-wire

Configuration of the electronics

The pluggable electronics is mounted in the electronics compartment of the instrument and can be exchanged by the user when servicing is required. The electronics is completely encapsulated to protect against vibration and moisture.

The contact pins with I²C interface for parameter adjustment are located on the upper side of the electronics. The terminals for the power supply are located in the separate connection compartment.

Voltage supply

If a reliable separation is required, the power supply and the current output are transmitted over separate two-wire connection cables.

- Operating voltage with version for low voltage
 - 9.6 ... 48 V DC, 20 ... 42 V AC, 50/60 Hz
- Operating voltage with version for mains voltage
 - 90 ... 253 V AC, 50/60 Hz

Connection cable

The 4 ... 20 mA current output is connected with standard two-wire cable without screen. If electromagnetic interference is expected which is above the test values of EN 61326 for industrial areas, screened cable should be used.

For power supply, an approved installation cable with PE conductor is required.

An outer cable diameter of 5 ... 9 mm ensures the seal effect of the respective cable entry.

Cable screening and grounding

If screened cable is required, we recommend connecting the cable screen on both ends to ground potential. In the sensor, the screen must be connected directly to the internal ground terminal. The ground terminal on the outside of the housing must be connected to the ground potential (low impedance).

Connection, double chamber housing

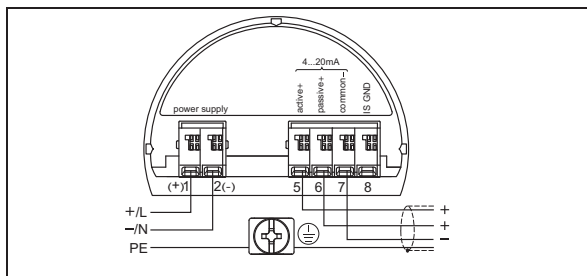

Fig. 21: Connection compartment, double chamber housing

- 1 Voltage supply
- 2 4 ... 20 mA signal output active
- 3 4 ... 20 mA signal output passive

Reading Office

Cutbush Park, Danehill, Lower Earley,
Reading, Berkshire. RG6 4UT. UK.
Tel: +44 (0)118 9311188
Email: info@able.co.uk

Aberdeen Office

Unit 6 Airside Business Park, Kirkhill Industrial Estate,
Dyce, Aberdeen. AB21 0GT. UK.
Tel: +44 (0)1224 725999
Email: ab@able.co.uk

Internet: www.able.co.uk
e-procurement: www.247able.com
Registered in England No: 01851002
VAT No: GB 417 2481 61



9 Electronics - Profibus PA

Configuration of the electronics

The pluggable electronics is mounted in the electronics compartment of the instrument and can be exchanged by the user when servicing is required. The electronics is completely encapsulated to protect against vibration and moisture.

The terminals for voltage supply as well as the plug with I²C interface for parameter adjustment are located on the upper side of the electronics. In the double-chamber housing, these connection elements are located in the separate terminal compartment.

Voltage supply

The voltage supply is provided by a Profibus DP /PA segment coupler.

Data of the voltage supply:

- Operating voltage
 - 9 ... 32 V DC
- Max. number of sensors per DP/PA segment coupler
 - 32

Connection cable

Connection is carried out with screened cable according to Profibus specification.

In the product configurator of VEGAFLEX, different cable glands are available. This selection covers all cable diameters in the range of 4 ... 12 mm (0.16 ... 0.47 in).

Make sure that the entire installation is carried out according to the Profibus specification. In particular, make sure that the bus is terminated with suitable terminating resistors.

Cable screening and grounding

With systems with potential equalisation, connect the cable screen directly to ground potential at the power supply unit, in the connection box and at the sensor. The screen in the sensor must be connected directly to the internal ground terminal. The ground terminal outside on the housing must be connected to the potential equalisation (low impedance).

In systems without potential equalisation, connect the cable screen directly to ground potential on the power supply unit and the sensor. In the connection box or T-distributor, the screen of the short stub to the sensor must not be connected to ground potential or to another cable screen.

Connection

Single chamber housing

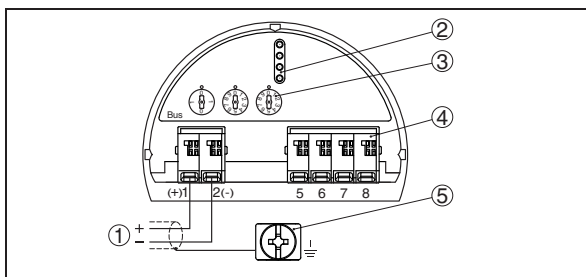

Fig. 22: Electronics and connection compartment, single chamber housing

- 1 Voltage supply/Signal output
- 2 For display and adjustment module or interface adapter
- 3 Selection switch for bus address
- 4 For external display and adjustment unit
- 5 Ground terminal for connection of the cable screen

Double chamber housing

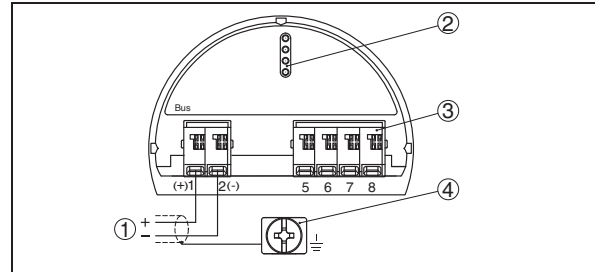

Fig. 23: Connection compartment, double chamber housing

- 1 Voltage supply/Signal output
- 2 For display and adjustment module or interface adapter
- 3 Ground terminal for connection of the cable screen

Wire assignment, connection cable with version IP 66/IP 68, 1 bar

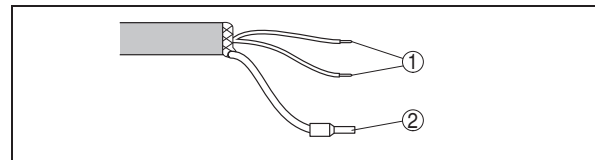

Fig. 24: Wire assignment fix-connected connection cable

- 1 brown (+) and blue (-) to power supply or to the processing system
- 2 Shielding

Reading Office

Cutbush Park, Danehill, Lower Earley,
Reading, Berkshire. RG6 4UT. UK.
Tel: +44 (0)118 9311188
Email: info@able.co.uk

Aberdeen Office

Unit 6 Airside Business Park, Kirkhill Industrial Estate,
Dyce, Aberdeen. AB21 0GT. UK.
Tel: +44 (0)1224 725999
Email: ab@able.co.uk

Internet: www.able.co.uk
e-procurement: www.247able.com
Registered in England No: 01851002
VAT No: GB 417 2481 61



10 Electronics - Foundation Fieldbus

Configuration of the electronics

The pluggable electronics is mounted in the electronics compartment of the instrument and can be exchanged by the user when servicing is required. The electronics is completely encapsulated to protect against vibration and moisture.

The terminals for voltage supply as well as the contact pins with I²C interface for parameter adjustment are located on the upper side of the electronics. In the double chamber housing, the terminals are located in the separate terminal compartment.

Voltage supply

Power supply via the H1 Fieldbus cable.

Data of the voltage supply:

- Operating voltage
 - 9 ... 32 V DC
- max. number of sensors
 - 32

Connection cable

Connection is carried out with screened cable according to Fieldbus specification.

In the product configurator of VEGAFLEX, different cable glands are available. This selection covers all cable diameters in the range of 4 ... 12 mm (0.16 ... 0.47 in).

Make sure that the entire installation is carried out according to the Fieldbus specification. In particular, make sure that the bus is terminated with suitable terminating resistors.

Cable screening and grounding

With systems with potential equalisation, connect the cable screen directly to ground potential at the power supply unit, in the connection box and at the sensor. The screen in the sensor must be connected directly to the internal ground terminal. The ground terminal outside on the housing must be connected to the potential equalisation (low impedance).

In systems without potential equalisation, connect the cable screen directly to ground potential on the power supply unit and the sensor. In the connection box or T-distributor, the screen of the short stub to the sensor must not be connected to ground potential or to another cable screen.

Connection

Single chamber housing

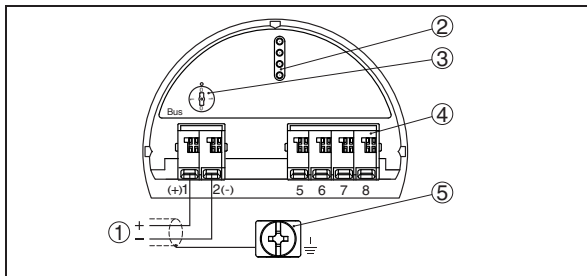

Fig. 25: Electronics and connection compartment, single chamber housing

- 1 Voltage supply/Signal output
- 2 Contact pins for the display and adjustment module or interface adapter
- 3 Selection switch for bus address
- 4 For external display and adjustment unit
- 5 Ground terminal for connection of the cable screen

Double chamber housing

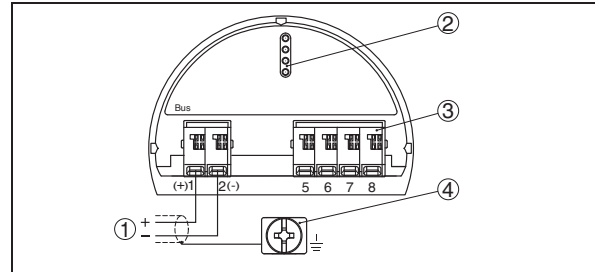

Fig. 26: Connection compartment, double chamber housing

- 1 Voltage supply/Signal output
- 2 For display and adjustment module or interface adapter
- 3 Ground terminal for connection of the cable screen

Wire assignment, connection cable with version IP 66/IP 68, 1 bar

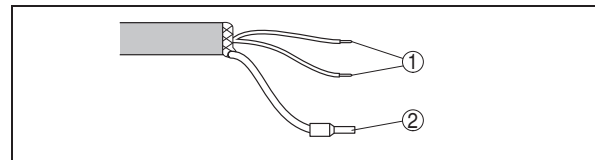

Fig. 27: Wire assignment fix-connected connection cable

- 1 brown (+) and blue (-) to power supply or to the processing system
- 2 Shielding

11 Electronics, Modbus, Levelmaster protocol

Configuration of the electronics

The pluggable electronics is mounted in the electronics compartment of the instrument and can be exchanged by the user when servicing is required. The electronics is completely encapsulated to protect against vibration and moisture.

The contact pins with I²C interface for parameter adjustment are located on the upper side of the electronics. The terminals for the power supply are located in the separate connection compartment.

Voltage supply

Power supply via the Modbus host (RTU)

- Operating voltage
 - 8 ... 30 V DC
- max. number of sensors
 - 32

Connection cable

Connection is carried out with screened cable according to Fieldbus specification.

For power supply, a separate two-wire cable is required.

In the product configurator of VEGAFLEX, different cable glands are available. This selection covers all cable diameters in the range of 4 ... 12 mm (0.16 ... 0.47 in).

Make sure that the entire installation is carried out according to the Fieldbus specification. In particular, make sure that the bus is terminated with suitable terminating resistors.

Cable screening and grounding

With systems with potential equalisation, connect the cable screen directly to ground potential at the power supply unit, in the connection box and at the sensor. The screen in the sensor must be connected directly to the internal ground terminal. The ground terminal outside on the housing must be connected to the potential equalisation (low impedance).

In systems without potential equalisation, connect the cable screen directly to ground potential on the power supply unit and the sensor. In the connection box or T-distributor, the screen of the short stub to the sensor must not be connected to ground potential or to another cable screen.

Connection compartment

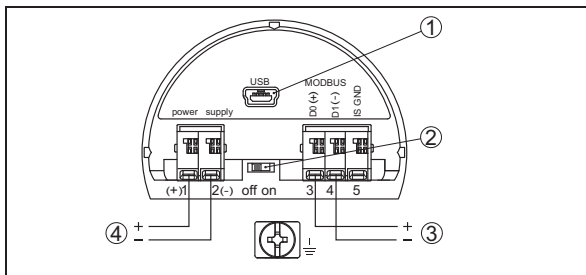

Fig. 28: Connection compartment

- 1 USB interface
- 2 Slide switch for integrated termination resistor (120 Ω)
- 3 Voltage supply
- 4 Modbus signal

Reading Office

Cutbush Park, Danehill, Lower Earley,
Reading, Berkshire. RG6 4UT. UK.
Tel: +44 (0)118 9311188
Email: info@able.co.uk

Aberdeen Office

Unit 6 Airside Business Park, Kirkhill Industrial Estate,
Dyce, Aberdeen. AB21 0GT. UK.
Tel: +44 (0)1224 725999
Email: ab@able.co.uk

Internet: www.able.co.uk
e-procurement: www.247able.com
Registered in England No: 01851002
VAT No: GB 417 2481 61



12 Operation

12.1 Overview

The sensors can be adjusted with the following adjustment media:

- With the display and adjustment module
- With external display and adjustment unit
- an adjustment software according to FDT/DTM standard, e.g. PACTware and PC

as well as via systems from other manufacturers, dependent on the signal output:

- A HART handheld (4 ... 20 mA/HART)
- The adjustment program AMS (4 ... 20 mA/HART and Foundation Fieldbus)
- The adjustment program PDM (Profibus PA)
- A configuration tool (Foundation Fieldbus)

The entered parameters are generally saved in the sensor, optionally also in the display and adjustment module or in the adjustment program.

12.2 Display and adjustment module PLICSCOM

The pluggable display and adjustment module is used for measured value indication, operation and diagnosis. It is equipped with an illuminated full dot matrix as well as four keys for adjustment.



Fig. 29: Display and adjustment module PLICSCOM

The display and adjustment module is integrated in the respective sensor housing or in the external indicating and adjustment unit. After mounting, the sensor as well as the display and adjustment module are splash-proof even without housing cover.

12.3 External display and adjustment unit VEGADIS 62

VEGADIS 62 is suitable for measured value indication and adjustment of sensors with HART protocol. The instrument is looped into the 4 ... 20 mA/HART signal cable.



Fig. 30: External display and adjustment unit VEGADIS 62

12.4 PACTware/DTM

As an alternative to the display and adjustment module, the sensor can also be configured via a Windows PC. To do this, the configuration software PACTware and a suitable instrument driver (DTM) according to the FDT

standard are required. The current PACTware version as well as all available DTMs are compiled in a DTM Collection. The DTMs can also be integrated into other frame applications according to the FDT standard.

All device DTMs are available as a free-of-charge standard version and as a full version that must be purchased. In the standard version, all functions for complete setup are already included. An assistant for simple project configuration simplifies the adjustment considerably. Saving/printing the project as well as import/export functions are also part of the standard version.

In the full version there is also an extended print function for complete project documentation as well as a save function for measured value and echo curves. In addition, there is a tank calculation program as well as a multiviewer for display and analysis of the saved measured value and echo curves.

Connection of the PC via VEGACONNECT

The interface converter VEGACONNECT is required for connection of the PC. On the computer side, the connection is made via USB interface. The VEGACONNECT is placed instead of the display and adjustment module to the sensor, the connection to the sensor is made automatically. As an alternative the connection via the HART signal can be carried out on any position of the signal cable with 4 ... 20 mA/HART sensors.

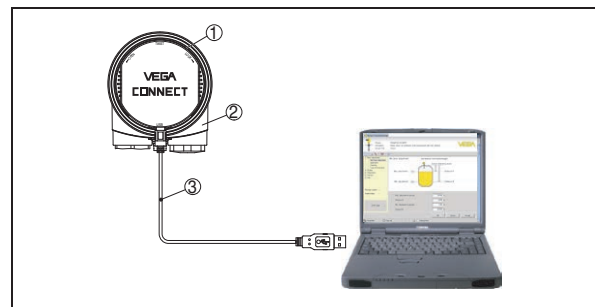

Fig. 31: Connection via VEGACONNECT and USB

- 1 VEGACONNECT
- 2 plics[®] sensor
- 3 USB cable to the PC

Necessary components:

- VEGAFLEX
- PC with PACTware and suitable DTM
- VEGACONNECT
- Voltage supply/Processing system

12.5 Alternative adjustment programs

PDM

For HART and Profibus PA sensors, device descriptions are available as EDDs for the adjustment program PDM. The device descriptions are already included in the current version of the PDM. Newer instrument drivers that are not yet delivered with the PDM are available in the download section.

AMS

For HART and Foundation Fieldbus sensors, device descriptions are available as EDDs for the adjustment program AMS. The device descriptions are already included in the current version of the AMS. Newer instrument drivers that are not yet delivered with the AMS are available in the download section.

13 Dimensions

Plastic housing

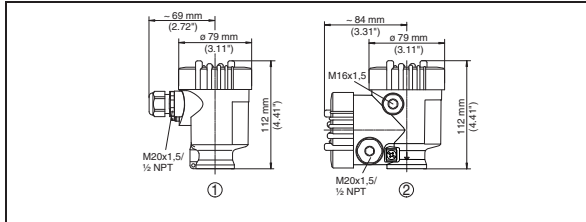

- 1 Single chamber housing
- 2 Double chamber housing

Aluminium housing

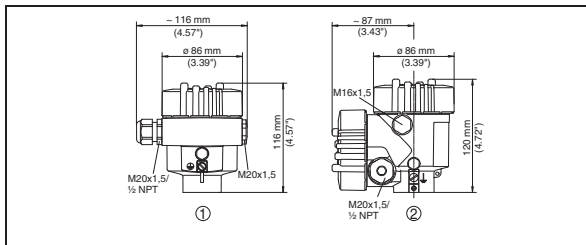

- 1 Single chamber housing
- 2 Double chamber housing

Stainless steel housing

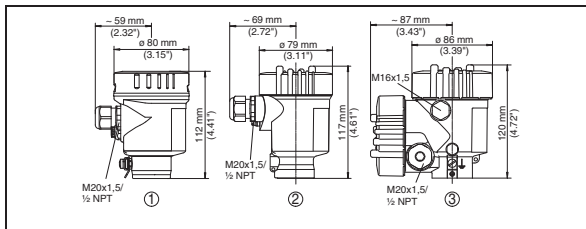

- 1 Single chamber housing, electropolished
- 2 Single chamber housing, precision casting
- 2 Double chamber housing, precision casting

VEGAFLEX 81, cable and rod version

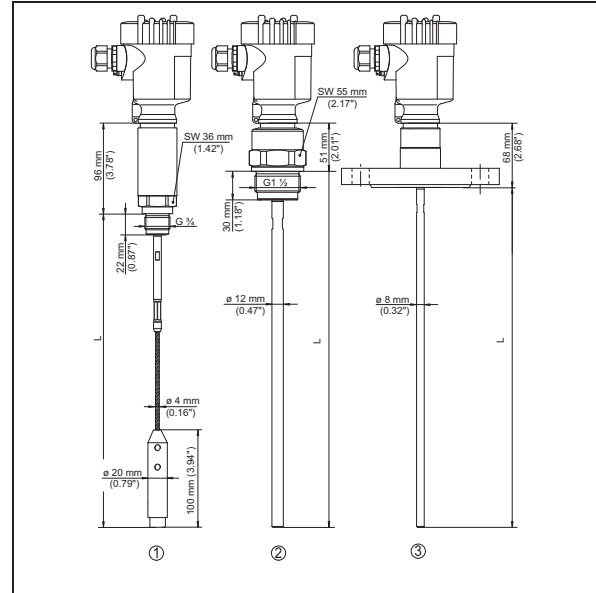

Fig. 32: VEGAFLEX 81, cable and rod version

- 1 Cable version, ϕ 4 mm (0.16 in) with threaded fitting
- 2 Rod version, ϕ 12 mm (0.47 in) with threaded fitting
- 3 Rod version, ϕ 8 mm (0.32 in) with flange connection
- L Sensor length, see chapter "Technical data"

VEGAFLEX 81, coax version

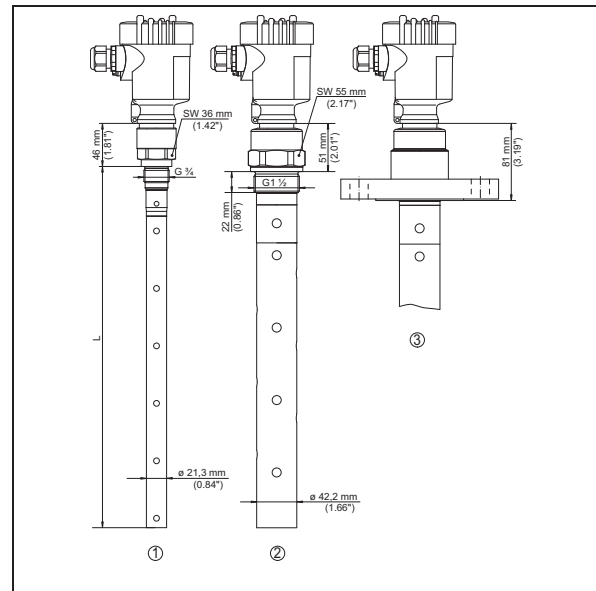

Fig. 34: VEGAFLEX 81, coax version

- 1 Coax version, ϕ 21.3 mm (0.84 in) with threaded fitting
- 2 Coax version, ϕ 42.2 mm (1.66 in) with threaded fitting
- 3 Coax version, ϕ 42.2 mm (1.66 in) with flange connection
- L Sensor length, see chapter "Technical data"

VEGAFLEX 83, PFA coated version

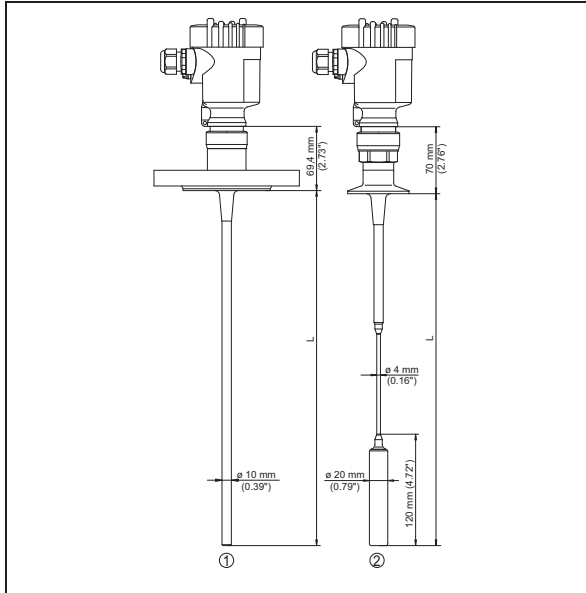

Fig. 36: VEGAFLEX 83, PFA coated version

- 1 Rod version, \varnothing 10 mm (0.39 in) with flange connection
- 2 Cable version, \varnothing 4 mm (0.16 in) with Clamp connection
- L Sensor length, see chapter "Technical data"

VEGAFLEX 83, polished version

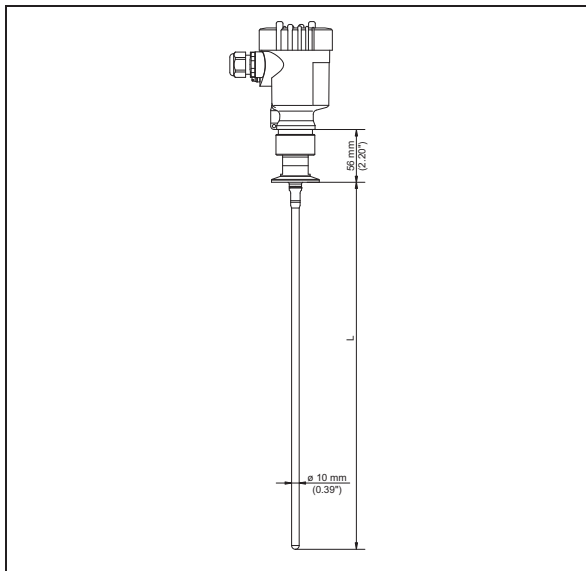

Fig. 38: VEGAFLEX 83, polished version (Basle Standard), rod version \varnothing 10 mm (0.39 in) with Clamp connection

- L Sensor length, see chapter "Technical data"

VEGAFLEX 86, cable, rod version

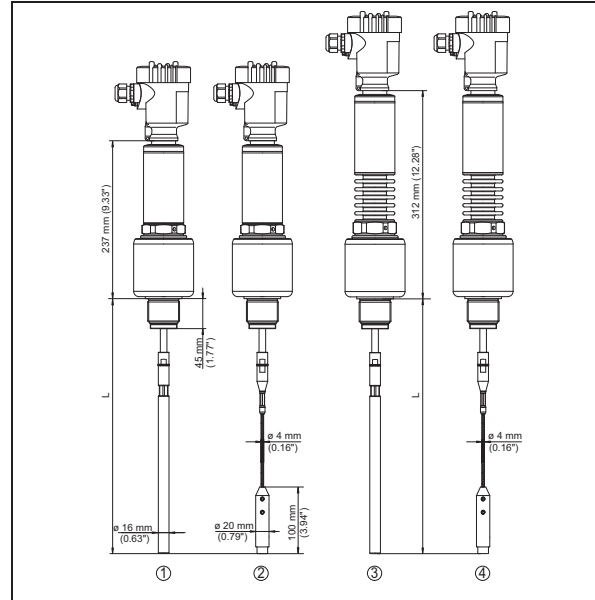

Fig. 40: VEGAFLEX 86, cable, rod version with threaded fitting

- 1 Rod version, \varnothing 16 mm (0.63 in), -20 ... +250 °C/-4 ... +482 °F
- 2 Cable version, \varnothing 4 mm (0.16 in), -20 ... +250 °C/-4 ... +482 °F
- 3 Rod version \varnothing 16 mm (0.63 in), -200 ... +400 °C/-328 ... +752 °F
- 4 Cable version, \varnothing 4 mm (0.16 in), -200 ... +400 °C/-328 ... +752 °F
- L Sensor length, see chapter "Technical data"

VEGAFLEX 86, coax version

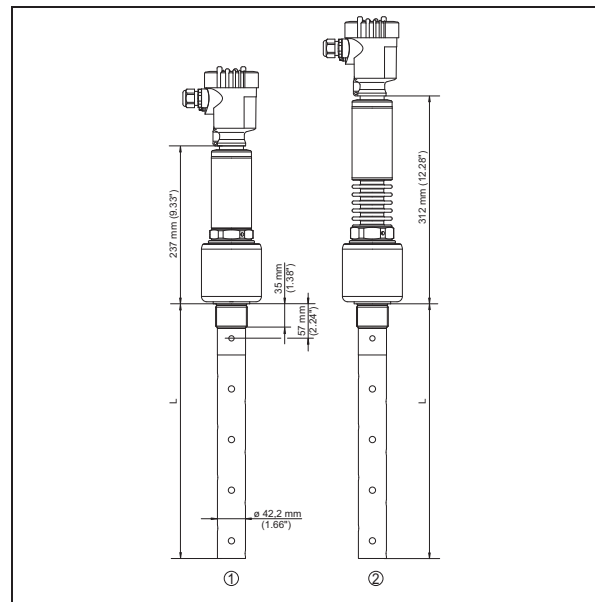

Fig. 42: VEGAFLEX 86, coax version with threaded fitting

- 1 Coax version, \varnothing 42.2 mm (1.66 in), -20 ... +250 °C/-4 ... +482 °F
- 2 Coax version, \varnothing 42.2 mm (1.66 in), -200 ... +400 °C/-328 ... +752 °F
- L Sensor length, see chapter "Technical data"

Reading Office

Cutbush Park, Danehill, Lower Earley,
Reading, Berkshire. RG6 4UT. UK.
Tel: +44 (0)118 9311188
Email: info@able.co.uk

Aberdeen Office

Unit 6 Airside Business Park, Kirkhill Industrial Estate,
Dyce, Aberdeen. AB21 0GT. UK.
Tel: +44 (0)1224 725999
Email: ab@able.co.uk

Internet: www.able.co.uk
e-procurement: www.247able.com
Registered in England No: 01851002
VAT No: GB 417 2481 61

