



Installation & Maintenance Instructions

VEGAFLEX 62

4 ... 20 mA/HART - two-wire

VEGA



Contents

1	About this document	
1.1	Function	4
1.2	Target group	4
1.3	Symbolism used	4
2	For your safety	
2.1	Authorised personnel	5
2.2	Appropriate use	5
2.3	Warning about misuse	5
2.4	General safety instructions	5
2.5	Safety label on the instrument	6
2.6	CE conformity	6
2.7	Fulfillment of NAMUR recommendations	6
2.8	Safety instructions for Ex areas	6
2.9	Environmental instructions	6
3	Product description	
3.1	Structure	7
3.2	Principle of operation	8
3.3	Operation	9
3.4	Packaging, transport and storage	9
4	Mounting	
4.1	General instructions	11
4.2	Mounting instructions	12
5	Connecting to power supply	
5.1	Preparing the connection	20
5.2	Connection procedure	21
5.3	Wiring plan, single chamber housing	22
5.4	Wiring plan, double chamber housing	23
5.5	Wiring plan with double chamber housing Ex d	25
5.6	Wiring plan - version IP 66/IP 68, 1 bar	27
6	Set up with the indicating and adjustment module PLICSCOM	
6.1	Short description	28
6.2	Insert indicating and adjustment module	28
6.3	Adjustment system	30
6.4	Setup steps	31
6.5	Menu schematic	37
6.6	Saving the parameter adjustment data	39
7	Set up with PACTware and other adjustment programs	
7.1	Connecting the PC	40
7.2	Parameter adjustment with PACTware	41
7.3	Parameter adjustment with AMS™ and PDM	42
7.4	Saving the parameter adjustment data	42

8	Maintenance and fault rectification	
8.1	Maintenance	43
8.2	Rectify malfunctions	43
8.3	Exchange or shorten cable/rod	45
8.4	Exchanging the electronics module	46
8.5	Software update	47
8.6	Instrument repair	48
9	Dismounting	
9.1	Dismounting steps	49
9.2	Disposal	49
10	Supplement	
10.1	Technical data	50
10.2	Dimensions	60

Supplementary documentation



Information:

Supplementary documents appropriate to the ordered version come with the delivery. You can find them listed in chapter "*Product description*".

Instructions manuals for accessories and replacement parts



Tip:

To ensure reliable setup and operation of your VEGAFLEX 62, we offer accessories and replacement parts. The corresponding documentations are:

- 27720 - VEGADIS 61
- 30207 - Electronics module VEGAFLEX series 60
- 34296 - Protective cover
- 31088 - Flanges according to DIN-EN-ASME-JIS-GOST
- 30391 - Spacer

1 About this document

1.1 Function

This operating instructions manual provides all the information you need for mounting, connection and setup as well as important instructions for maintenance and fault rectification. Please read this information before putting the instrument into operation and keep this manual accessible in the immediate vicinity of the device.

1.2 Target group

This operating instructions manual is directed to trained qualified personnel. The contents of this manual should be made available to these personnel and put into practice by them.

1.3 Symbolism used



Information, tip, note

This symbol indicates helpful additional information.



Caution: If this warning is ignored, faults or malfunctions can result.

Warning: If this warning is ignored, injury to persons and/or serious damage to the instrument can result.

Danger: If this warning is ignored, serious injury to persons and/or destruction of the instrument can result.



Ex applications

This symbol indicates special instructions for Ex applications.



List

The dot set in front indicates a list with no implied sequence.



Action

This arrow indicates a single action.



Sequence

Numbers set in front indicate successive steps in a procedure.

2 For your safety

2.1 Authorised personnel

All operations described in this operating instructions manual must be carried out only by trained specialist personnel authorised by the plant operator.

During work on and with the device the required personal protective equipment must always be worn.

2.2 Appropriate use

VEGAFLEX 62 is a sensor for continuous level measurement.

You can find detailed information on the application range in chapter "*Product description*".

Operational reliability is ensured only if the instrument is properly used according to the specifications in the operating instructions manual as well as possible supplementary instructions.

For safety and warranty reasons, any invasive work on the device beyond that described in the operating instructions manual may be carried out only by personnel authorised by the manufacturer. Arbitrary conversions or modifications are explicitly forbidden.

2.3 Warning about misuse

Inappropriate or incorrect use of the instrument can give rise to application-specific hazards, e.g. vessel overfill or damage to system components through incorrect mounting or adjustment.

2.4 General safety instructions

This is a high-tech instrument requiring the strict observance of standard regulations and guidelines. The user must take note of the safety instructions in this operating instructions manual, the country-specific installation standards as well as all prevailing safety regulations and accident prevention rules.

The instrument must only be operated in a technically flawless and reliable condition. The operator is responsible for trouble-free operation of the instrument.

During the entire duration of use, the user is obliged to determine the compliance of the necessary occupational safety measures with the current valid rules and regulations and also take note of new regulations.

2.5 Safety label on the instrument

The safety approval markings and safety tips on the device must be observed.

2.6 CE conformity

This device fulfills the legal requirements of the applicable EC guidelines. By attaching the CE mark, VEGA provides a confirmation of successful testing. You can find the CE conformity declaration in the download area of www.vega.com.

2.7 Fulfillment of NAMUR recommendations

With respect to compatibility, the NAMUR recommendation NE 53 is fulfilled. This applies also to the corresponding indicating and adjustment components. VEGA instruments are generally upward and downward compatible.

- Sensor software to DTM VEGAFLEX 62
- DTM VEGAFLEX 62 for adjustment software PACTware
- Indicating and adjustment module for sensor software

The parameter adjustment of the basic sensor functions is independent of the software version. The range of available functions depends on the respective software version of the individual components.

2.8 Safety instructions for Ex areas

Please note the Ex-specific safety information for installation and operation in Ex areas. These safety instructions are part of the operating instructions manual and come with the Ex-approved instruments.

2.9 Environmental instructions

Protection of the environment is one of our most important duties. That is why we have introduced an environment management system with the goal of continuously improving company environmental protection. The environment management system is certified according to DIN EN ISO 14001.

Please help us fulfil this obligation by observing the environmental instructions in this manual:

- Chapter "*Packaging, transport and storage*"
- Chapter "*Disposal*"

3 Product description

3.1 Structure

Scope of delivery

The scope of delivery encompasses:

- VEGAFLEX 62 level sensor
- Documentation
 - this operating instructions manual
 - Safety Manual 31339 "*VEGAFLEX series 60 - 4 ... 20 mA/HART*" (optional)
 - Operating instructions manual 27835 "*Indicating and adjustment module PLICSCOM*" (optional)
 - Supplementary instructions manual 31708 "*Heating for indicating and adjustment module*" (optional)
 - Supplementary instructions manual "*Plug connector for continuously measuring sensors*" (optional)
 - Ex-specific "*Safety instructions*" (with Ex versions)
 - if necessary, further certificates

Constituent parts

The VEGAFLEX 62 consists of the components:

- Process fitting with probe
- Housing with electronics
- Housing cover, optionally available with indicating and adjustment module

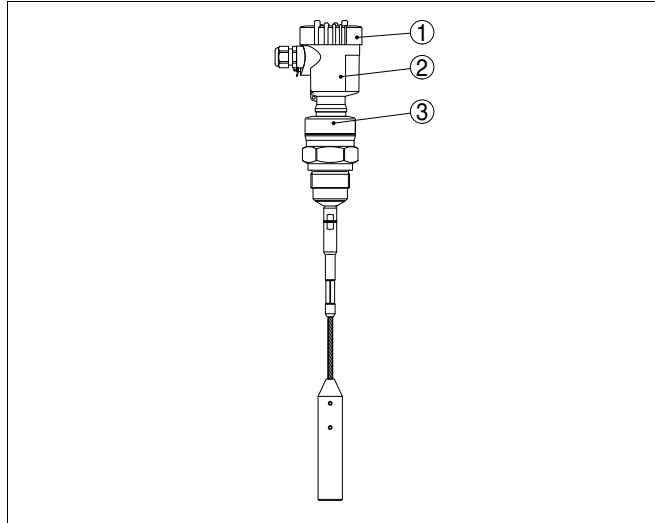

Fig. 1: VEGAFLEX 62 in cable version with plastic housing

- 1 Housing cover with integrated indicating and adjustment module (optional)
- 2 Housing with electronics
- 3 Process fitting

Type label

The type label contains the most important data for identification and use of the instrument:

- Article number
- Serial number
- Technical data
- Article numbers, documentation
- SIL identification (with SIL rating ex works)

With the serial number, you can access the delivery data of the instrument via www.vega.com, "VEGA Tools" and "serial number search". In addition to the type label outside, you can also find the serial number on the inside of the instrument.

3.2 Principle of operation

Application area

VEGAFLEX 62 is a level sensor with cable or rod probe for continuous level measurement.

It is designed for industrial use in all areas of process technology and can be used equally well in liquids or solids.

Functional principle

High frequency microwave pulses are guided along a steel rope or a rod. Upon reaching the product surface, the microwave pulses are reflected. The running time is evaluated by the instrument and outputted as distance.

Voltage supply

Two-wire electronics 4 ... 20 mA/HART for power supply and measured value transmission over the same cable.

The supply voltage range can differ depending on the instrument version.

The data for power supply are specified in chapter "*Technical data*".

The optional background lighting of the indicating and adjustment module is powered by the sensor. A certain level of operating voltage is required for this. You can find the exact voltage specifications in chapter "*Technical data*".

The optional heating requires its own operating voltage. You can find details in the supplementary instructions manual "*Heating for indicating and adjustment module*".

This function is generally not available for approved instruments.

3.3 Operation

VEGAFLEX 62 can be adjusted with different adjustment media:

- with indicating and adjustment module
- with the suitable VEGA DTM in conjunction with an adjustment software according to the FDT/DTM standard, e.g. PACTware and PC
- with manufacturer-specific adjustment programs AMS™ or PDM
- With a HART handheld

3.4 Packaging, transport and storage

Packaging

Your instrument was protected by packaging during transport. Its capacity to handle normal loads during transport is assured by a test according to DIN EN 24180.

The packaging of standard instruments consists of environment-friendly, recyclable cardboard. For special versions, PE foam or PE foil is also used. Dispose of the packaging material via specialised recycling companies.

Transport

Transport must be carried out under consideration of the notes on the transport packaging. Nonobservance of these instructions can cause damage to the device.

Transport inspection

The delivery must be checked for completeness and possible transit damage immediately at receipt. Ascertained transit damage or concealed defects must be appropriately dealt with.

Storage

Up to the time of installation, the packages must be left closed and stored according to the orientation and storage markings on the outside.

Unless otherwise indicated, the packages must be stored only under the following conditions:

- Not in the open
 - Dry and dust free
 - Not exposed to corrosive media
 - Protected against solar radiation
 - Avoiding mechanical shock and vibration
- Storage and transport temperature**
- Storage and transport temperature see chapter "*Supplement - Technical data - Ambient conditions*"
 - Relative humidity 20 ... 85 %

4 Mounting

4.1 General instructions

Suitability for the process conditions

Make sure that all parts of the instrument exposed to the process, in particular the sensor element, process seal and process fitting, are suitable for the existing process conditions. These include above all the process pressure, process temperature as well as the chemical properties of the medium.

You can find the specifications in chapter "*Technical data*" or on the type label.

Mounting position

Select an installation position you can easily reach for mounting and connecting as well as later retrofitting of an indicating and adjustment module. The housing can be rotated by 330° without the use of any tools. You can also install the indicating and adjustment module in four different positions (each displaced by 90°).

Welding work

Before beginning the welding work, remove the electronics module from the sensor. By doing this, you avoid damage to the electronics through inductive coupling.

Handling

With threaded versions, the housing must not be used to screw in the instrument! Applying tightening forces on the housing can damage its internal parts.

Use the hexagon for screwing in.

Moisture

Use the recommended cables (see chapter "*Connecting to power supply*") and tighten the cable gland.

You can give your instrument additional protection against moisture penetration by leading the connection cable downward in front of the cable entry. Rain and condensation water can thus drain off. This applies mainly to outdoor mounting as well as installation in areas where high humidity is expected (e.g. through cleaning processes) or on cooled or heated vessels.

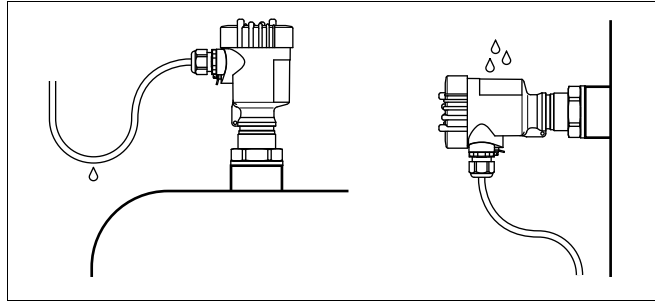

Fig. 2: Measures against moisture penetration

Measuring range

The reference plane for the measuring range of the sensors is the sealing surface of the thread or flange.

Keep in mind that a min. distance must be maintained below the reference plane and possibly also at the end of the probe - measurement in these areas is not possible (dead band). Keep in mind that the cable length cannot be used all the way to the end because measurement in the area of the gravity weight is not possible. These dead bands are listed in chapter "*Technical data*". Keep in mind for the adjustment that the default setting for the measuring range refers to water.

Pressure

The process fitting must be sealed if there is gauge or low pressure in the vessel. Before use, check if the seal material is resistant against the measured product and the process temperature.

The max. permissible pressure is specified in chapter "*Technical data*" or on the type label of the sensor.

4.2 Mounting instructions

Mounting position

Mount VEGAFLEX 62 in such a way that the distance to vessel installations or to the vessel wall is at least 300 mm (12 in).

During operation, the probe must not touch any installations or the vessel wall. If necessary, fasten the probe end.

In vessels with conical bottom it can be advantageous to mount the sensor in the center of the vessel, as measurement is then possible down to the lowest point of the bottom. When using the cable version,

keep in mind that measurement down to the tip of the probe is not possible. The exact value of the min. distance (lower dead band) is stated in chapter "Technical data".

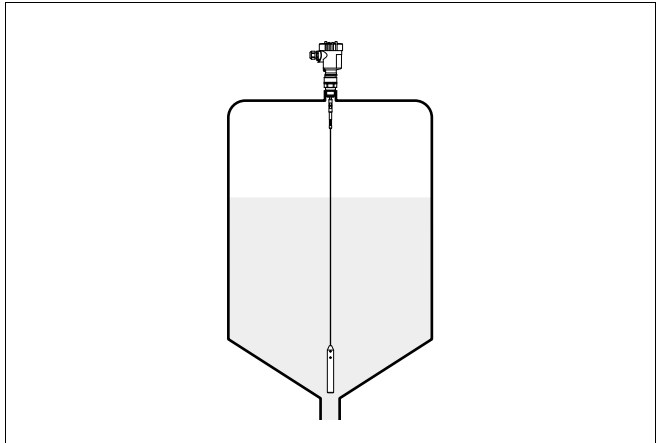

Fig. 3: Vessel with conical bottom

Rod extensions

In case of difficult installation conditions, the probe can be also mounted laterally. For this purpose, adapt the rod with rod extensions or bow-shaped segments.

The sensor must be readjusted to compensate the resulting running time changes.

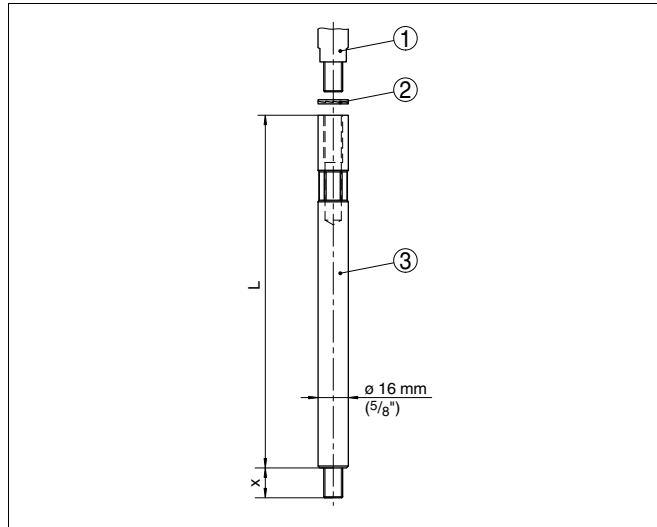

Fig. 4: Extension rod $\varnothing 16 \text{ mm}$ (0.63 in)

- 1 Probe
- 2 Retaining ring
- 3 Extension rod
- L Rod length 100 ... 2000 mm (3.937 ... 78.74 in)
- x Thread length 18 mm (0.709 in)

Make sure that the rod of the probe is at least 300 mm (11.811 in) away from the vessel wall

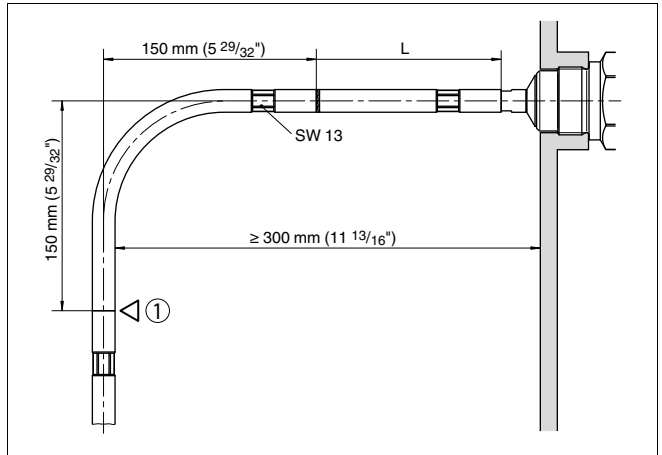

Fig. 5: Bow-shaped segment \varnothing 16 mm (0.63 in)

1 Max. filling height

L 150 mm (5.91 in)

Vessel type

Plastic vessel/Glass vessel

The guided microwave principle requires a metal surface on the process fitting. Therefore use in plastic vessels etc. an instrument version with flange (from DN 50) or place a metal sheet ($\varnothing > 200$ mm/ 8 in) beneath the process fitting when screwing it in.

Make sure that the plate has direct contact with the process fitting.

In bypass tubes of plastic, a metal screen must be provided on the outside. You can glue metal foil, for example, on the outside along the entire length of the tube. This metal screen must be connected to the ground terminal on the instrument.

When installing rod or cable probes without metal vessel wall, e.g. in plastic vessels, the measured value can be influenced by strong electromagnetic fields (emitted interference according to EN 61326: class A).

In this case, use a probe in coax version.

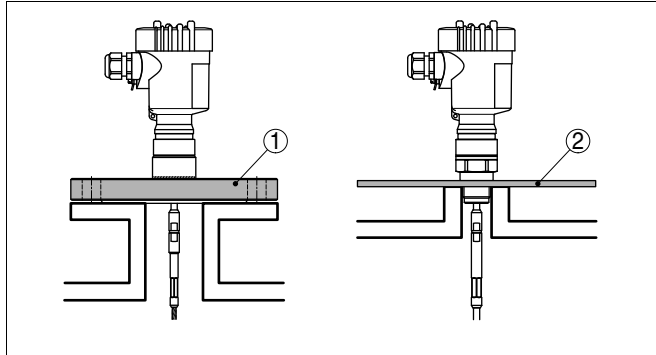

Fig. 6: Installation in plastic silo

- 1 Flange
- 2 Metal sheet

Concrete vessel

When installed in thick concrete ceilings, VEGAFLEX 62 should be mounted front flush to the lower edge. In concrete silos, the distance to the wall should be at least 500 mm (20 in).

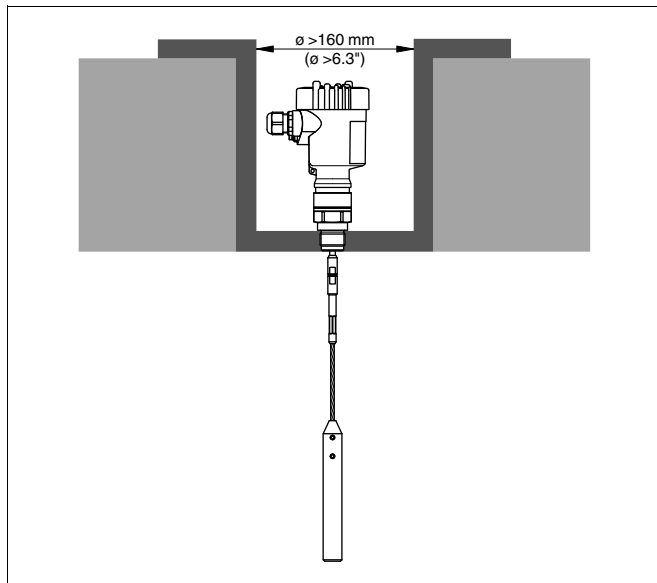

Fig. 7: Installation in concrete silo

Socket

If possible, avoid sockets. Mount the sensor flush with the vessel top. If this is not possible, use short sockets with small diameter.

Higher sockets or sockets with a bigger diameter can generally be used. They simply increase the upper dead band. Check if this is relevant for your measurement.

In such cases, always carry out a gating out of false signals after installation. You can find further information under "Setup procedure".

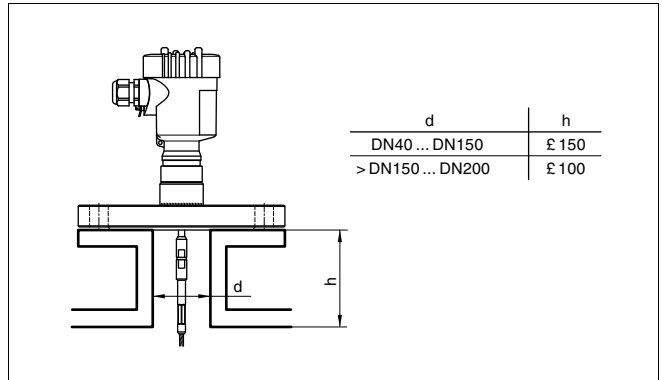

Fig. 8: Mounting socket

When welding the socket, make sure that the socket is flush to the vessel wall.

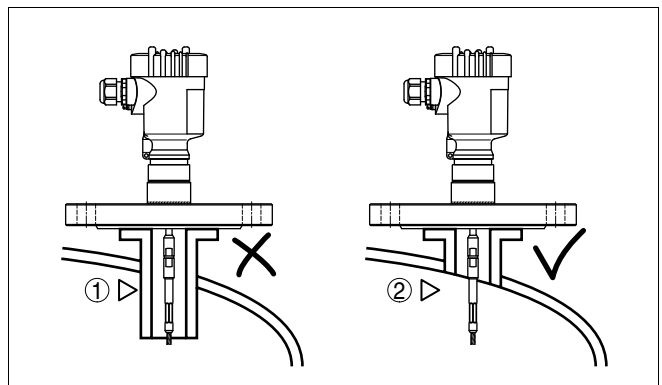

Fig. 9: Socket must be installed flush

- 1 Unfavourable installation
- 2 Socket flush - optimum installation

Standpipes or bypass tubes

Standpipes or bypass tubes are normally metal tubes with a diameter of 30 ... 200 mm (1.18 ... 7.87 in). In measurement technology such a tube corresponds to a coax probe. It does not matter if the standpipe is perforated or slotted for better mixing. Lateral inlets with bypass tubes also do not influence the measurement.

Measuring probes can be mounted in bypass tubes up to DN 200.

If VEGAFLEX 62 is used in standpipes or bypass tubes, contact with the tube wall should be avoided. We offer spacers as accessories for fastening the probe in the middle of the tube.

Depending on the tube diameter or tube length, one or several spacers can be mounted. With cable probes, the cable can also be strained to avoid contact with the tube.

Keep in mind that buildup can form on the spacers. Strong buildup can influence the measurement.

Microwaves can penetrate plastics. For process technical reasons, plastic standpipes are problematic. If durability is no problem, then we recommend the use of metal standpipes.

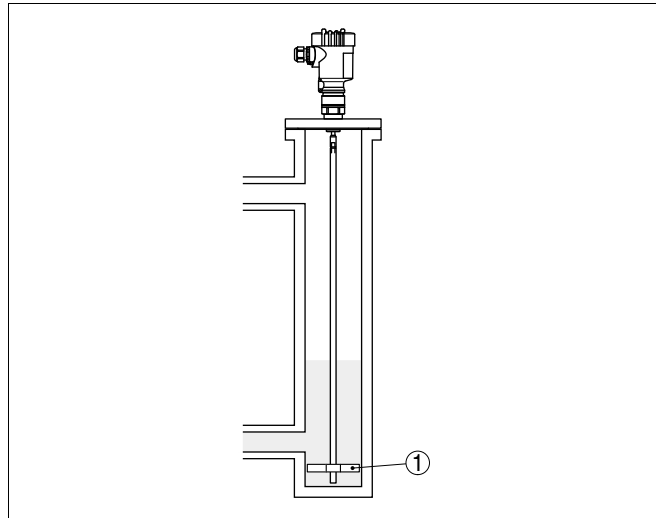

Fig. 10: Position of the spacer

1 Spacer



Note:

Measurement in a standpipe is not recommended for very adhesive products.

Inflowing medium

Make sure that the probe is not subjected to strong lateral forces. Mount VEGAFLEX 62 at a position in the vessel where no disturbances, e.g. from filling openings, agitators, etc., can occur.

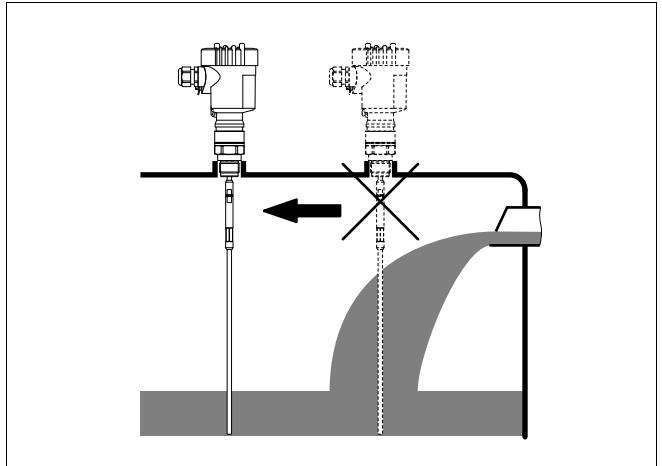

Fig. 11: Lateral load

Fixing

If there is a danger of the probe touching the vessel wall during operation due to product movements or agitators etc., the measuring probe should be securely fixed.

In the gravity weight there is a thread (M12), e.g. for a ring bolt (optional) - (article no. 2.27424).

Make sure that the probe cable is not completely taut. Avoid tensile loads on the cable.

Avoid undefined cable-vessel connections, i.e. the connection must be either grounded reliably or isolated reliably. Any deviation from this requirement can lead to measurement errors.

5 Connecting to power supply

5.1 Preparing the connection

Safety instructions

Always keep in mind the following safety instructions:

- Connect only in the complete absence of line voltage
- If overvoltage surges are expected, overvoltage arresters should be installed



Tip:

We recommend using VEGA overvoltage arresters B63-48 and ÜSB 62-36G.X.



In hazardous areas you should take note of the appropriate regulations, conformity and type approval certificates of the sensors and power supply units.

Voltage supply

Power supply and current signal are carried on the same two-wire cable. The voltage supply range can differ depending on the instrument version.

The data for power supply are specified in chapter "*Technical data*".

Provide a reliable separation between the supply circuit and the mains circuits according to DIN VDE 0106 part 101. The VEGA power supply units VEGATRENN 149A Ex, VEGASTAB 690 as well as all VEGAMETs and VEGASCANs meet this requirement.

Keep in mind the following additional influences on the operating voltage:

- Output voltage of the power supply unit can be lower under nominal load (with a sensor current of 20.5 mA or 22 mA in case of fault message)
- Influence of additional instruments in the circuit (see load values in chapter "*Technical data*")

Connection cable

The instrument is connected with standard two-wire cable without screen. If electromagnetic interference is expected which is above the test values of EN 61326 for industrial areas, screened cable should be used.

Use cable with round cross-section. A cable outer diameter of 5 ... 9 mm (0.2 ... 0.35 in) ensures the seal effect of the cable gland. If you are using cable with a different diameter or cross-section, exchange the seal or use a suitable cable gland.

We generally recommend the use of screened cable for HART multidrop mode.

Cable gland ½ NPT

On the instrument with cable entry ½ NPT and plastic housing there is a metallic ½" threaded insert moulded into the plastic housing.

**Caution:**

No grease should be used when screwing the NPT cable gland or steel tube into the threaded insert. Standard grease can contain additives that corrode the connection between threaded insert and housing. This would influence the stability of the connection and the tightness of the housing.

Cable screening and grounding

If screened cable is necessary, connect the cable screen on both ends to ground potential. In the sensor, the screen must be connected directly to the internal ground terminal. The ground terminal on the outside of the housing must be connected to the potential equalisation (low impedance).

If potential equalisation currents are expected, the connection on the processing side must be made via a ceramic capacitor (e. g. 1 nF, 1500 V). The low frequency potential equalisation currents are thus suppressed, but the protective effect against high frequency interference signals remains.



Take note of the corresponding installation regulations for Ex applications. In particular, make sure that no potential equalisation currents flow over the cable screen. In case of grounding on both sides this can be achieved by the use of a capacitor or a separate potential equalisation.

5.2 Connection procedure

Proceed as follows:

- 1 Unscrew the housing cover
- 2 If an indicating and adjustment module is installed, remove it by turning it slightly to the left.
- 3 Loosen compression nut of the cable entry
- 4 Remove approx. 10 cm (4 in) of the cable mantle, strip approx. 1 cm (0.4 in) of insulation from the ends of the individual wires
- 5 Insert the cable into the sensor through the cable entry
- 6 Lift the opening levers of the terminals with a screwdriver (see following illustration)

- 7 Insert the wire ends into the open terminals according to the wiring plan



Fig. 12: Connection steps 6 and 7

- 8 Press down the opening levers of the terminals, you will hear the terminal spring closing
 - 9 Check the hold of the wires in the terminals by lightly pulling on them
 - 10 Connect the screen to the internal ground terminal, connect the outer ground terminal to potential equalisation
 - 11 Tighten the compression nut of the cable entry. The seal ring must completely encircle the cable
 - 12 Screw the housing cover on
- The electrical connection is finished.

5.3 Wiring plan, single chamber housing



The following illustrations apply to the non-Ex as well as to the Ex-ia version.

Electronics and connection compartment

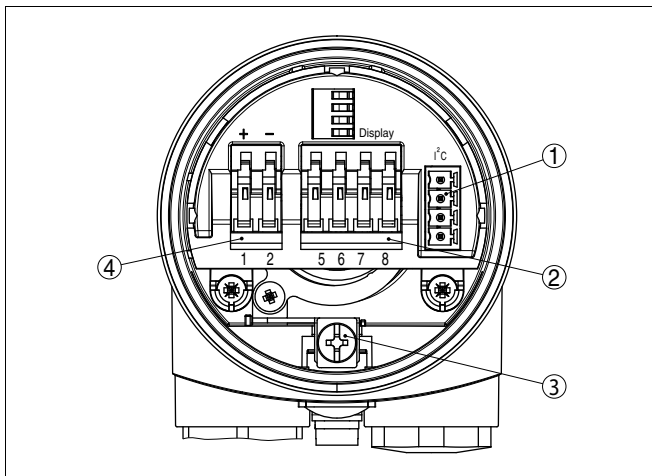

Fig. 13: Electronics and connection compartment with single chamber housing

- 1 Plug connector for VEGACONNECT (I²C interface)
- 2 Spring-loaded terminals for connection of the external indication VEGADIS 61
- 3 Ground terminal for connection of the cable screen
- 4 Spring-loaded terminals for voltage supply

Wiring plan

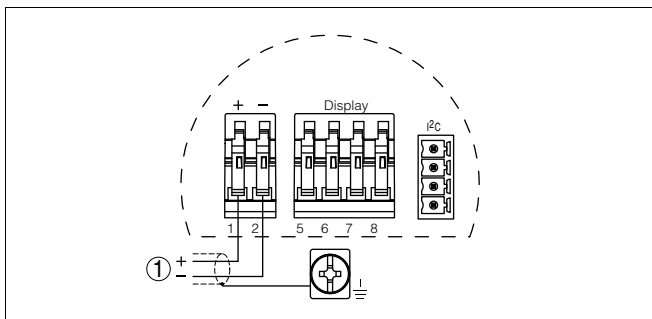

Fig. 14: Wiring plan, single chamber housing

- 1 Voltage supply/Signal output

5.4 Wiring plan, double chamber housing



The following illustration apply to non-Ex as well as Ex ia versions. The Exd version is described in the next subchapter.

Electronics compartment

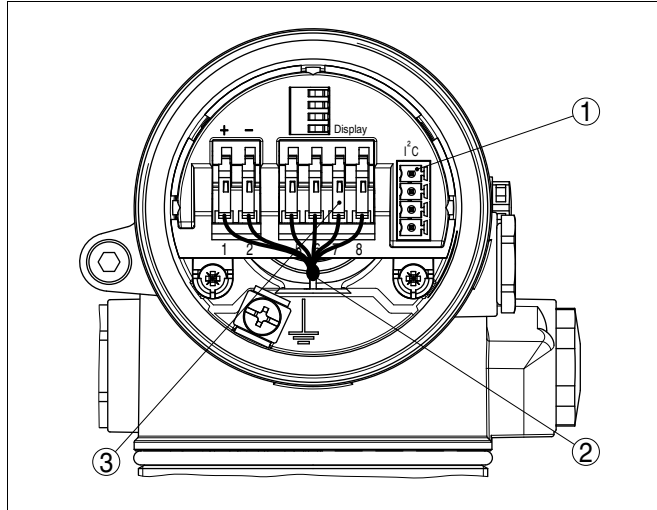

Fig. 15: Electronics compartment, double chamber housing

- 1 Plug connector for VEGACONNECT (I²C interface)
- 2 Internal connection cable to the connection compartment
- 3 Terminals for VEGADIS 61

Connection compartment

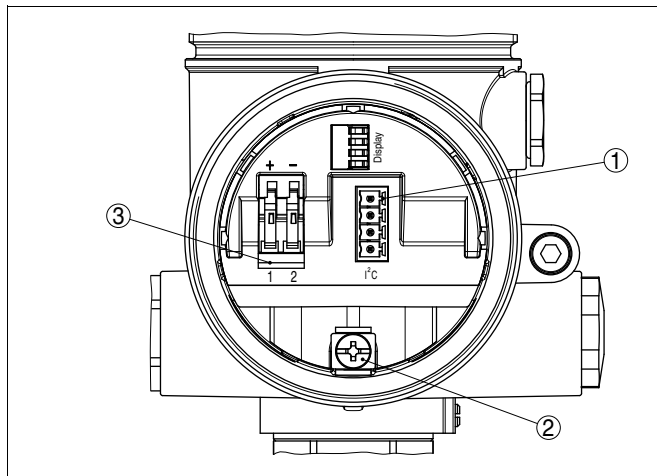

Fig. 16: Connection compartment, double chamber housing

- 1 Plug connector for VEGACONNECT (I²C interface)
- 2 Ground terminal for connection of the cable screen
- 3 Spring-loaded terminals for voltage supply

Wiring plan

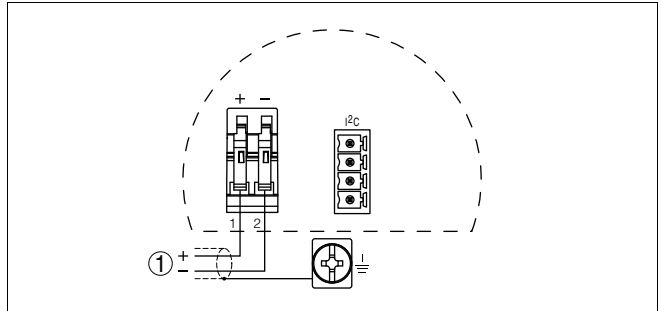

Fig. 17: Wiring plan with double chamber housing

- 1 Voltage supply/Signal output

5.5 Wiring plan with double chamber housing Ex d

Electronics compartment

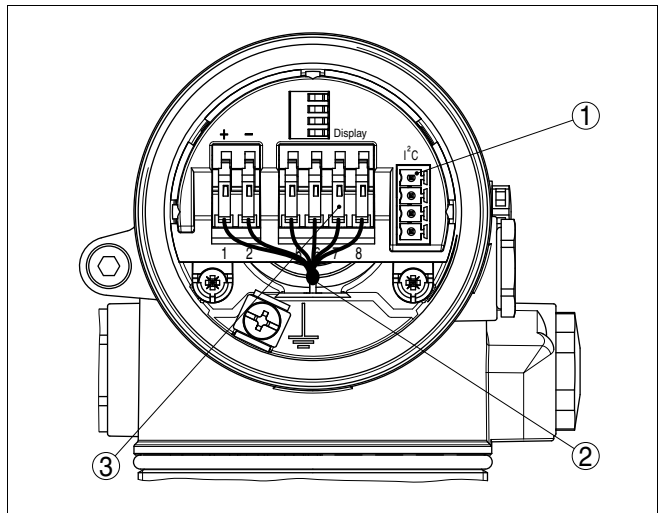

Fig. 18: Electronics compartment, double chamber housing

- 1 Plug connector for VEGACONNECT (i²C interface)
- 2 Internal connection cable to the connection compartment
- 3 Terminals for VEGADIS 61

Connection compartment

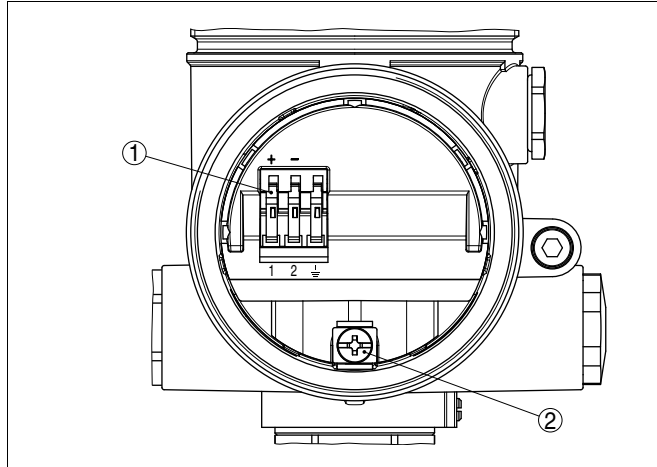

Fig. 19: Connection compartment with double chamber housing Ex d

- 1 Spring-loaded terminals for power supply and cable screen
- 2 Ground terminal for connection of the cable screen

Wiring plan

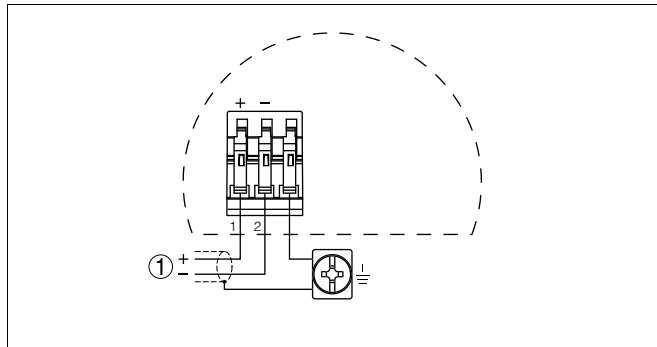

Fig. 20: Wiring plan with double chamber housing Ex d

- 1 Voltage supply/Signal output

5.6 Wiring plan - version IP 66/IP 68, 1 bar

Wire assignment connection cable

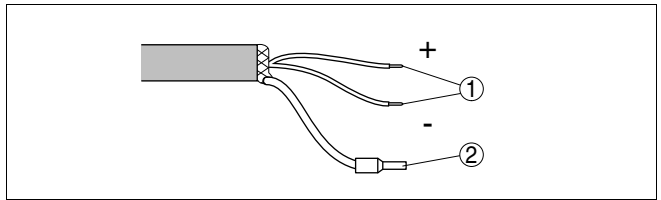

Fig. 21: Wire assignment connection cable

- 1 brown (+) and blue (-) to power supply or to the processing system
- 2 Shielding

6 Set up with the indicating and adjustment module PLICSCOM

6.1 Short description

Function/Configuration

The indicating and adjustment module is used for measured value display, adjustment and diagnosis. It can be mounted in the following housing versions and instruments:

- All sensors of the plics[®] instrument family, in the single as well as in the double chamber housing (optionally in the electronics or connection compartment)
- External indicating and adjustment unit VEGADIS 61

From a hardware version ...- 01 or higher of the indicating and adjustment module as well as of the corresponding sensor, an integrated backlight can be switched on via the adjustment menu. The hardware version is stated on the type label of the indicating and adjustment module or the sensor electronics.



Note:

You can find detailed information on the adjustment in the operating instructions manual "*Indicating and adjustment module*".

6.2 Insert indicating and adjustment module

Mount/Dismount indicating and adjustment module

The indicating and adjustment module can be inserted into the sensor and removed again at any time. It is not necessary to interrupt the power supply.

Proceed as follows:

- 1 Unscrew the housing cover
- 2 Place the indicating and adjustment module in the desired position on the electronics (you can choose any one of four different positions - each displaced by 90°)
- 3 Press the indicating and adjustment module onto the electronics and turn it to the right until it snaps in.
- 4 Screw housing cover with inspection window tightly back on

Removal is carried out in reverse order.

The indicating and adjustment module is powered by the sensor, an additional connection is not necessary.

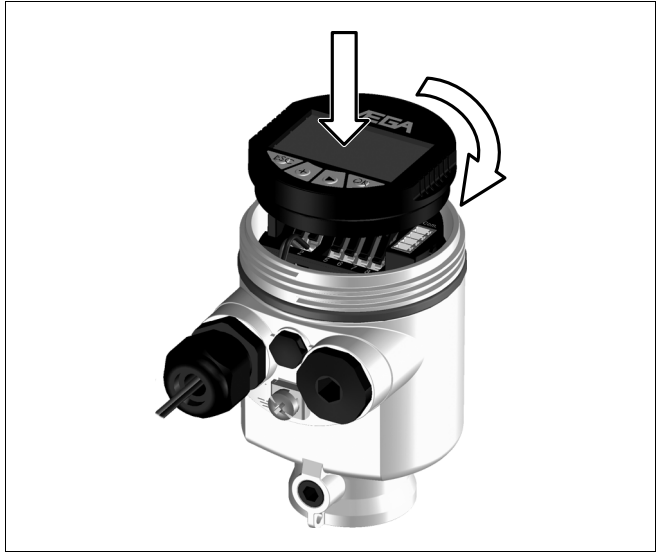

Fig. 22: Insert indicating and adjustment module



Note:

If you intend to retrofit the instrument with an indicating and adjustment module for continuous measured value indication, a higher cover with an inspection glass is required.

6.3 Adjustment system

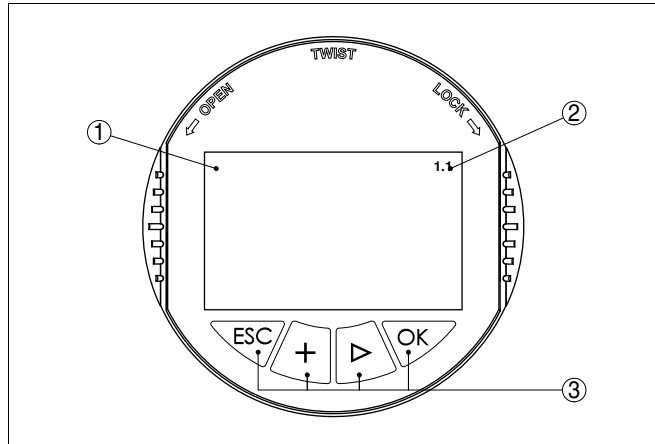

Fig. 23: Indicating and adjustment elements

- 1 LC display
- 2 Indication of the menu item number
- 3 Adjustment keys

Key functions

- **[OK]** key:
 - Move to the menu overview
 - Confirm selected menu
 - Edit parameter
 - Save value
- **[->]** key to select:
 - Menu change
 - Select list entry
 - Select editing position
- **[+]** key:
 - Change value of the parameter
- **[ESC]** key:
 - interrupt input
 - jump to the next higher menu

Adjustment system

The sensor is adjusted via the four keys of the indicating and adjustment module. The LC display indicates the individual menu items. The functions of the individual keys are shown in the above illustration. Approx. 10 minutes after the last pressing of a key, an automatic reset to measured value indication is triggered. Any values not confirmed with **[OK]** will not be saved.

6.4 Setup steps

Switch on phase

After connecting VEGAFLEX 62 to power supply or after a voltage recurrence, the instrument carries out a self-check for approx. 30 seconds:

- Internal check of the electronics
- Indication of the instrument type, the firmware as well as the sensor TAGs (sensor designation)
- Output signal jumps briefly (approx. 10 seconds) to the set fault current

Then the corresponding current is outputted to the cable (the value corresponds to the actual level as well as the settings already carried out, e.g. factory setting).

Address setting HART-Multidrop

In HART-Multidrop mode (several sensors on one input) the address must be set before continuing with the parameter adjustment. You will find a detailed description in the operating instructions manual "*Indicating and adjustment module*" or in the online help of PACTware or DTM.

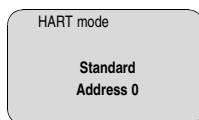

Parameter adjustment

As VEGAFLEX 62 is a distance measuring instrument, the distance from the sensor to the product surface is measured. To have the real product level displayed, an allocation of the measured distance to the percentage height must be made. To carry out this adjustment, the distance is entered with full and empty vessel. If these values are not known, an adjustment with the distance values, e.g. 10 % and 90 % is also possible. Starting point for these distance specifications is always the seal surface of the thread or flange. With these settings, the real level is calculated. Furthermore the operating range of the sensor is limited from maximum to the required range.

The real product level during this adjustment is not important, because the min./max. adjustment is always carried out without changing the product level. These settings can be made ahead of time without the instrument having to be installed.

In the main menu item "*Basic adjustment*", the individual submenu items should be selected one after the other and provided with the correct parameter values.



Caution:

If there is a separation of different liquids in the vessel, e.g. by condensation, VEGAFLEX 62 will always detect the medium with the higher dielectric factor (ϵ_r).

Keep in mind that interfaces can cause faulty measurements.

If you want to measure the total height of both liquids reliably, please contact our service department or use an instrument specially designed for interface measurement.

Start your parameter adjustment with the following menu items of the basic adjustment:

Carry out min. adjustment

Proceed as follows:

- 1 Move from the measured value display to the main menu by pushing **[OK]**.

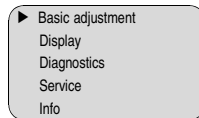

- 2 Select the menu item "Basic adjustment" with **[->]** and confirm with **[OK]**. Now the menu item "Min. adjustment" is displayed.

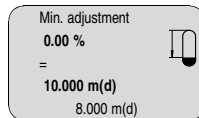

- 3 Prepare the % value for editing with **[OK]** and set the cursor to the requested position with **[->]**. Set the requested percentage value with **[+]** and save with **[OK]**. The cursor jumps now to the distance value.
- 4 Enter the suitable distance value in m for the empty vessel (e.g. distance from the sensor to the vessel bottom) corresponding to the percentage value.
- 5 Save the settings with **[OK]** and move to "Max. adjustment" with **[->]**.

Carry out max. adjustment

Proceed as follows:

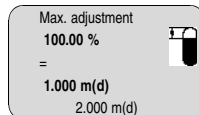

- 1 Prepare the % value for editing with **[OK]** and set the cursor to the requested position with **[->]**. Set the requested percentage value with **[+]** and save with **[OK]**. The cursor jumps now to the distance value.

- 2 Enter the appropriate distance value in m (corresponding to the percentage value) for the full vessel. Keep in mind that the max. level must lie below the dead band.
- 3 Save the settings with **[OK]**.

Application

Each product has different reflective properties. In addition, there are various interfering factors which have to be taken into account: agitated product surfaces and foam generation (with liquids); dust generation, material cones and echoes from the vessel wall (with solids). To adapt the sensor to these different conditions, you should first select in this menu item under "Medium" either "Liquid" or "Solid".

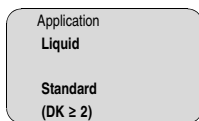

Depending on the dielectric figure (dielectric value or ϵ_r), measured products can have a different reflective property. Therefore an additional selection possibility is available.

Under "Sensitivity" you can select "Standard (DK ≥ 2)" or "Increased sensitivity (DK < 2)".

Through this the sensor is optimally adapted to the product and measurement reliability, particularly in products with bad reflective properties, is considerably increased.

Enter the requested parameters via the appropriate keys, save your settings and jump to the next menu item with the **[->]** key.

Damping

To suppress fluctuations in the measured value display, e. g. caused by an agitated product surface, a damping can be set. This time can be between 0 and 999 seconds. Keep in mind that the reaction time of the entire measurement will then be longer and the sensor will react to measured value changes with a delay. In general, a period of a few seconds is sufficient to smooth the measured value display.

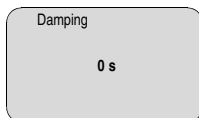

Enter the requested parameters via the appropriate keys, save your settings and jump to the next menu item with the **[->]** key.

Linearisation curve

A linearization is necessary for all vessels in which the vessel volume does not increase linearly with the level - e.g. in a horizontal cylindrical or spherical tank - and the indication or output of the volume is required. Corresponding linearization curves are preprogrammed for

these vessels. They represent the correlation between the level percentage and vessel volume. By activating the appropriate curve, the volume percentage of the vessel is displayed correctly. If the volume should not be displayed in percent but e.g. in l or kg, a scaling can be also set in the menu item "*Display*".

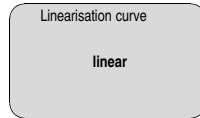

Enter the requested parameters via the appropriate keys, save your settings and jump to the next menu item with the [*->*] key.



Caution:

Note the following, if VEGAFLEX 62 is used as part of an overflow protection system according to WHG:

If a linearisation curve is selected, the measuring signal is no longer compulsorily linear proportional to the level. This must be taken into consideration by the user, particularly when adjusting the switching point on the level switch.

Sensor-TAG

In this menu item you can enter an unambiguous designation for the sensor, e.g. the measurement loop name or the tank or product designation. In digital systems and in the documentation of larger plants, a singular designation should be entered for exact identification of individual measuring points.

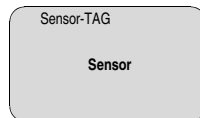

With this menu item, the Basic adjustment is finished and you can now jump to the main menu with the [*ESC*] key.

Gating out of false signals

High sockets or vessel installations, such as e. g. struts or agitators as well as buildup and weld joints on the vessel walls, cause interfering reflections which can impair the measurement. A false echo storage detects and marks these false echoes, so that they are no longer taken into account for the level measurement. A false echo memory should be created with low level so that all potential interfering reflections can be detected.

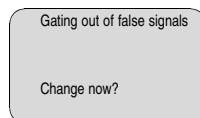

Proceed as follows:

- 1 Move from the measured value display to the main menu by pushing **[OK]**.
- 2 Select the menu item "Service" with **[->]** and confirm with **[OK]**. Now the menu item "False signal suppression" is displayed.
- 3 Confirm "False signal suppression - Change now" with **[OK]** and select in the below menu "Create new". Enter the actual distance from the sensor to the product surface. All false signals in this area are detected by the sensor and saved after confirming with **[OK]**.



Note:

Check the distance to the product surface, because if an incorrect (too large) value is entered, the existing level will be saved as false signal. The filling level would then no longer be detectable in this area.

Copy sensor data

This function enables reading out parameter adjustment data as well as writing parameter adjustment data into the sensor via the indicating and adjustment module. A description of the function is available in the operating instructions manual "*Indicating and adjustment module*".

The following data are read out or written with this function:

- Measured value presentation
- Adjustment
- Medium
- Vessel form
- Damping
- Linearisation curve
- Sensor-TAG
- Displayed value
- Display unit
- Scaling
- Current output
- Unit of measurement
- Language
- Sensitivity

The following safety-relevant data are **not** read out or written:

- HART mode
- PIN
- SIL
- Sensor length/Sensor type
- Gating out of false signals

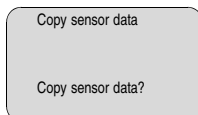

Reset**Basic adjustment**

If the function "Reset" is carried out, the sensor resets the values of the following menu items to the reset values (see chart):¹⁾

The following values will be reset:

Function	Reset value
Max. adjustment	Distance, upper dead zone
Min. adjustment - Rod/Coax version	Distance, supplied sensor length
Min. adjustment - Cable version	Distance, lower dead zone
Damping t_i	0 s
Linearisation	linear
Sensor-TAG	Sensor
Display	Distance
Current output - characteristics	4 ... 20 mA
Current output - max. current	20 mA
Current output - min. current	4 mA
Current output - failure	< 3.6 mA
Application - rod/coax version	Liquid
Application - Cable version	Bulk solid

The values of the following menu items are *not* reset to the reset values (see chart) with "Reset":

Menu item	Reset value
Lighting	No reset
Language	No reset
SIL	No reset
HART mode	No reset

Factory setting

Like basic adjustment, in addition, special parameters are reset to default values.²⁾

Pointer

The min. and max. values are reset to the actual value.

Optional settings

Additional adjustment and diagnosis options such as e.g. scaling, simulation or trend curve presentation are shown in the following menu schematic. You will find a detailed description of these menu items in the operating instructions manual "*Indicating and adjustment module*".

¹⁾ Sensor-specific basic adjustment.

²⁾ Special parameters are parameters which are set customer-specifically on the service level with the adjustment software PACTware.

6.5 Menu schematic

Basic adjustment

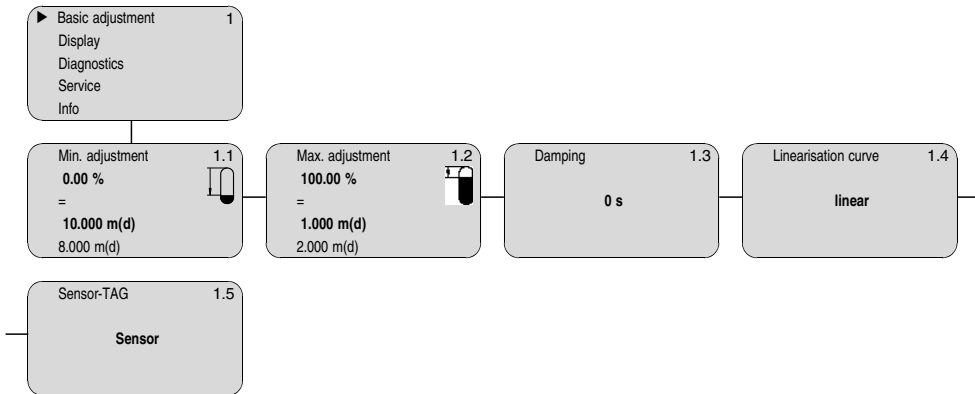

Display

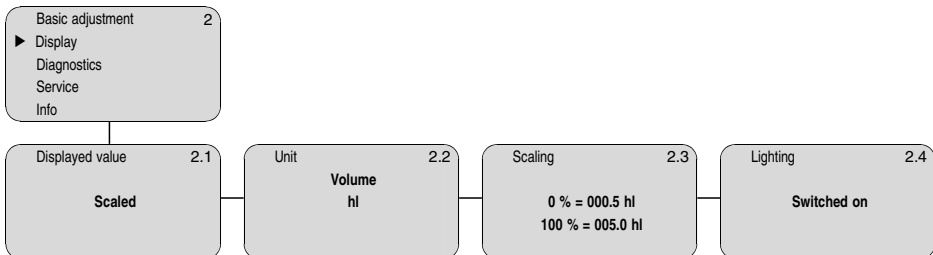

Diagnostics

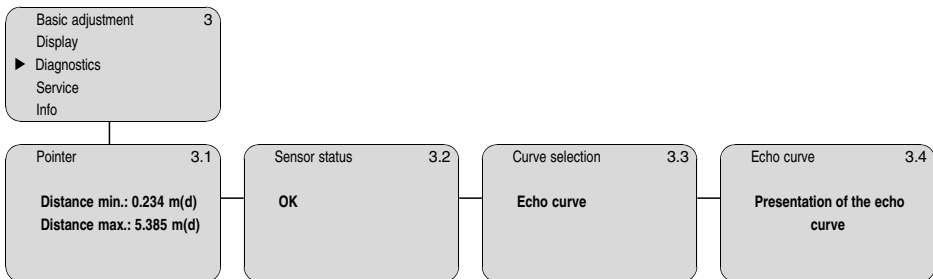

Service

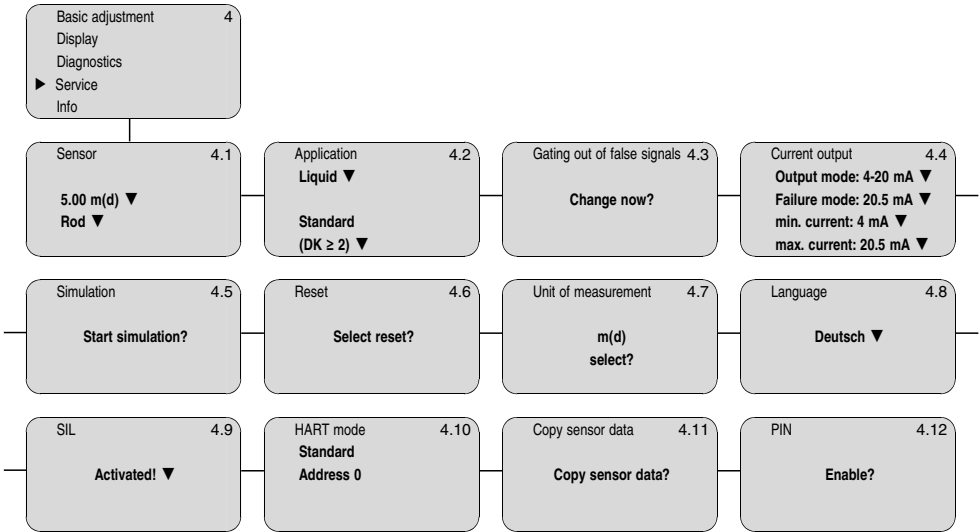

Info

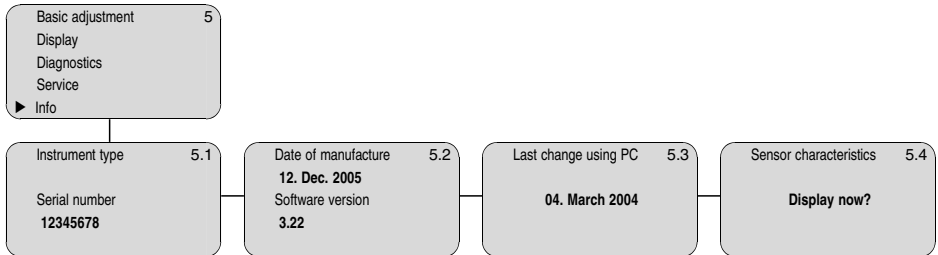

6.6 Saving the parameter adjustment data

It is recommended noting the adjusted data, e.g. in this operating instructions manual and archive them afterwards. They are hence available for multiple use or service purposes.

If VEGAFLEX 62 is equipped with an indicating and adjustment module, the most important data can be read out of the sensor into indicating and adjustment module. The procedure is described in the operating instructions manual "*Indicating and adjustment module*" in the menu item "*Copy sensor data*". The data remain there permanently even if the sensor power supply fails.

If it is necessary to exchange the sensor, the indicating and adjustment module is inserted into the replacement instrument and the data are written into the sensor under the menu item "*Copy sensor data*".

7 Set up with PACTware and other adjustment programs

7.1 Connecting the PC

VEGACONNECT directly on the sensor

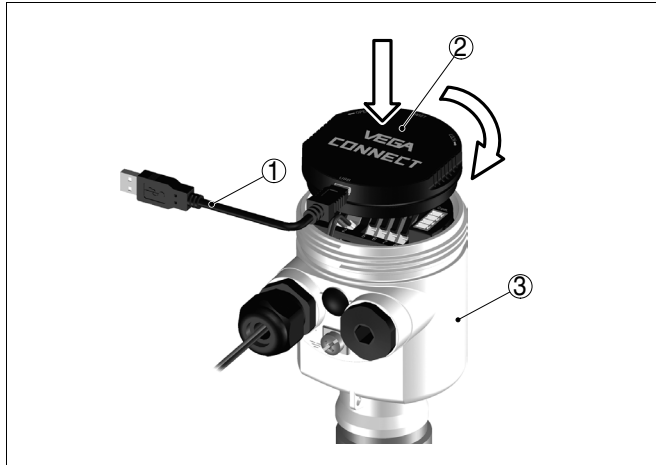

Fig. 24: Connection of the PC via VEGACONNECT directly to the sensor

- 1 USB cable to the PC
- 2 VEGACONNECT
- 3 Sensor

VEGACONNECT externally

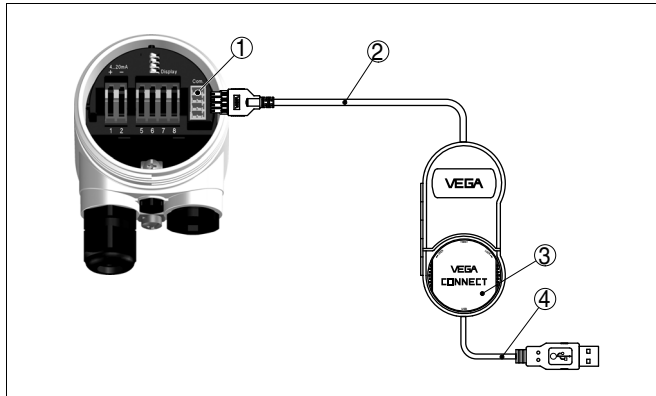

Fig. 25: Connection via VEGACONNECT externally

- 1 I²C bus (com.) interface on the sensor
- 2 I²C connection cable of VEGACONNECT
- 3 VEGACONNECT
- 4 USB cable to the PC

Necessary components:

- VEGAFLEX 62
- PC with PACTware and suitable VEGA DTM
- VEGACONNECT
- Power supply unit or processing system

VEGACONNECT via HART

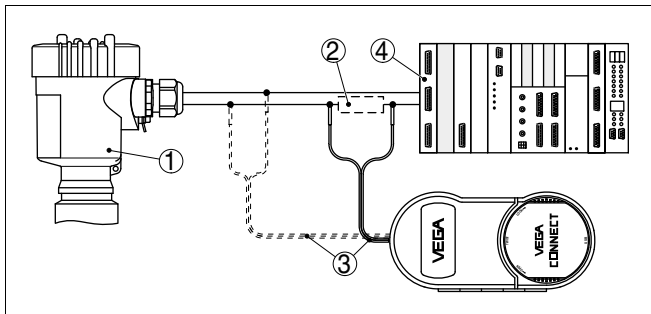

Fig. 26: Connecting the PC via HART to the signal cable

- 1 VEGAFLEX 62
- 2 HART resistance 250 Ω (optional depending on processing)
- 3 Connection cable with 2 mm pins and terminals
- 4 Processing system/PLC/Voltage supply

Necessary components:

- VEGAFLEX 62
- PC with PACTware and suitable VEGA DTM
- VEGACONNECT
- HART resistance approx. 250 Ω
- Power supply unit or processing system



Note:

With power supply units with integrated HART resistance (internal resistance approx. 250 Ω), an additional external resistance is not necessary. This applies, e. g. to the VEGA instruments VEGATRENN 149A, VEGADIS 371, VEGAMET 381. Common Ex separators are also usually equipped with a sufficient current limitation resistance. In such cases, VEGACONNECT 4 can be connected parallel to the 4 ... 20 mA cable.

7.2 Parameter adjustment with PACTware

Further setup steps are described in the operating instructions manual "DTM Collection/PACTware" attached to each CD and which can also be downloaded from our homepage. A detailed description is available in the online help of PACTware and the VEGA DTMs.

**Note:**

Keep in mind that for setup of VEGAFLEX 62, DTM-Collection in the actual version must be used.

All currently available VEGA DTMs are included as a DTM Collection on a CD. They can be purchased for a token fee from the responsible VEGA agency. In addition, the actual PACTware version is also available on this CD.

In addition, this DTM Collection incl. the basic version of PACTware can be downloaded free of charge from the Internet. Move via www.vega.com and "Downloads" to "Software".

7.3 Parameter adjustment with AMS™ and PDM

For VEGA sensors, instrument descriptions for the adjustment programs AMS™ and PDM are available as DD or EDD. The instrument descriptions are already implemented in the current versions of AMS™ and PDM.

For older versions of AMS™ and PDM, a free-of-charge download is available via Internet. Move via www.vega.com and "Downloads" to "Software".

7.4 Saving the parameter adjustment data

It is recommended to document or save the parameter adjustment data. That way they are available for multiple use or service purposes.

The VEGA DTM Collection and PACTware in the licensed, professional version provide suitable tools for systematic project documentation and storage.

8 Maintenance and fault rectification

8.1 Maintenance

When used as directed in normal operation, VEGAFLEX 62 is completely maintenance free.

8.2 Rectify malfunctions

Reaction when malfunctions occur

The operator of the system is responsible for taking suitable measures to remove interferences.

Causes of malfunction

VEGAFLEX 62 offers maximum reliability. Nevertheless, faults can occur during operation. These may be caused by the following, e.g.:

- Sensor
- Process
- Voltage supply
- Signal processing

Fault rectification

The first measures to be taken are to check the output signals as well as to evaluate the error messages via the indicating and adjustment module. The procedure is described below. Further comprehensive diagnostics can be carried out on a PC with the software PACTware and the suitable DTM. In many cases, the causes can be determined this way and faults rectified.

24 hour service hotline

However, should these measures not be successful, call the VEGA service hotline in urgent cases under the phone no. **+49 1805 858550**.

The hotline is available to you 7 days a week round-the-clock. Since we offer this service world-wide, the support is only available in the English language. The service is free of charge, only the standard telephone costs will be charged.

Checking the 4 ... 20 mA signal

Connect a handmultimeter in the suitable measuring range according to the wiring plan. The following table describes possible errors in the current signal and helps to remove them:

Error	Cause	Removal
4 ... 20 mA signal not stable	Level fluctuations	Set damping via the indicating and adjustment module
4 ... 20 mA signal missing	Electrical connection faulty	Check connection according to chapter " <i>Connection steps</i> " and if necessary, correct according to chapter " <i>Wiring plan</i> "

Error	Cause	Removal
	Voltage supply missing	Check cables for breaks; repair if necessary
	Operating voltage too low or load resistance too high	Check, adapt if necessary
Current signal greater than 22 mA or less than 3.6 mA	Oscillator in the sensor defective	Exchange the instrument or send it in for repair



In Ex applications, the regulations for the wiring of intrinsically safe circuits must be observed.

Error messages via the indicating and adjustment module

The indicating and adjustment modules indicate faults via error codes and text messages. The following table describes the error codes with status according to NE 107 and gives information on the causes of failure and their removal:

Status according to NE 107	Error code	Text message	Cause/Rectification
Failure	E013	no measured value available	Sensor in boot phase
		no measured value available	Sensor does not find an echo, e.g. due to faulty installation or wrong parameter adjustment
		no measured value available	Wrong sensor length entered
	E017	Adjustment span too small	Adjustment not within the specification. Carry out the adjustment again, increasing the distance between min. and max. adjustment
	E036	No operable software	Failed or interrupted software update/Repeat software update
	E042	Hardware error, electronics defective	Exchange the instrument or send it in for repair
	E043	Hardware error, electronics defective	Exchange the instrument or send it in for repair

Reaction after fault rectification

Depending on the failure reason and measures taken, the steps described in chapter "Set up" must be carried out again, if necessary.

8.3 Exchange or shorten cable/rod

Exchanging the cable/rod

The cable or rod (meas. part) of the probe can be shortened, if necessary. To loosen the meas. part you need two fork spanners with spanner width 8.

- 1 Loosen the measuring component by applying a fork spanner to the flat surfaces (SW 8), provide counterforce with another fork spanner (SW 8)
- 2 Unscrew the loosened measuring component manually
- 3 Place the enclosed new double washer onto the thread.

**Caution:**

Make sure that the two components of the double washer remain together.

- 4 Screw in a new measuring part manually
- 5 Exert counterforce with the second fork spanner and tighten the measuring component on the flat surfaces with a torque of 15 Nm (11 lbf ft).

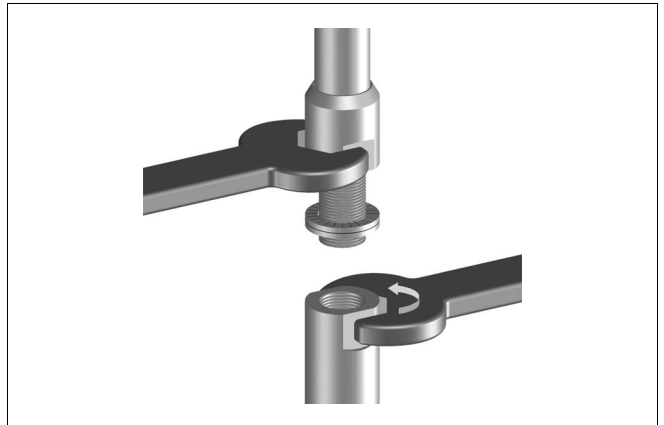

Fig. 27: Exchanging the cable or rod

**Information:**

Please keep the stated torque so that the max. tensile strength remains.

Shorten cable/rod

The cable and rod of the probe can be shortened by any amount.

- 1 Cable: loosen the three pins on the gravity weight (hexagon 4)
- 2 Cable: remove the pins

- 3 Cable: Pull the cable out of the gravity weight
- 4 Shorten the cable/rod with a cut-off wheel or metal saw at the lower end. Make sure the length is correct.
- 5 Cable: cable protrudes approx. 65 mm (2.4 in) into the gravity weight.
- 6 Cable: Fasten the cable with three pins, torque 20 Nm (14.75 lbf in)
- 7 Enter new probe length and then carry out a fresh adjustment (see "Setup procedure, Carrying out min. adjustment - Carrying out max. adjustment").

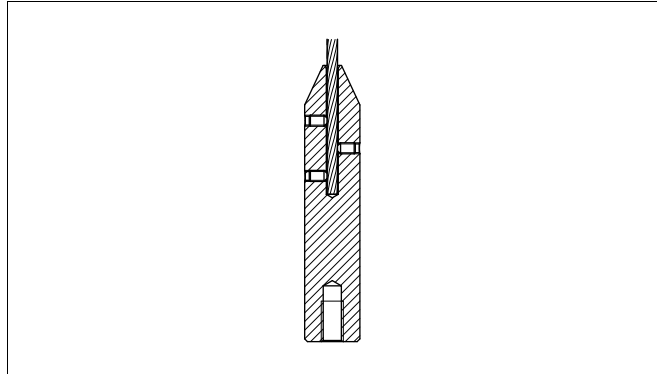

Fig. 28: Shortening the cable probe

8.4 Exchanging the electronics module

If the electronics module is defective, it can be replaced by the user.



In Ex applications only one instrument and one electronics module with respective Ex approval may be used.

If there is no electronics module available on site, one can be ordered from the VEGA agency serving you.

Sensor serial number

The new electronics module must be loaded with the settings of the sensor. These are the options:

- At the factory by VEGA
- Or on site by the user

In both cases, the sensor serial number is necessary. The serial numbers are stated on the type label of the instrument, inside the housing or on the delivery note.



Information:

When loading on site, first of all the order data must be downloaded from the Internet (see operating instructions manual "Oscillator").

Assignment

The electronics modules are adapted to the respective sensor and distinguish also in the signal output or power supply.

4 ... 20 mA/HART

Electronics module FX-E.60H suitable for VEGAFLEX 61, 62, 63, 65, 66 - 4 ... 20mA/HART:

- FX-E.60HX (X = without approvals)
- FX-E.60HA (A = approvals CA, DA according to product list)
- FX-E.60HC (C = approvals XM, CX, CM, CK, CI, DX, DM, DI, GX, UX, UF according to product list)

8.5 Software update

The software version of VEGAFLEX 62 can be determined as follows:

- on the type label of the electronics
- via the indicating and adjustment module
- via PACTware

You can view all software histories on our website www.vega.com.

Make use of this advantage and get registered for update information via e-mail.

The following components are required to update the sensor software:

- Sensor
- Voltage supply
- VEGACONNECT
- PC with PACTware
- Current sensor software as file

Load sensor software to PC

At "www.vega.com/downloads" go to "*Software*". Select under "*plics instruments and sensors*" the suitable instrument series. Load the zip file via the right mouse key with "*Save target as*" e.g. on the desktop of your PC. Extract all files available in the zip file, e.g. to the desktop.

Prepare update

Connect the sensor to power supply and provide connection from PC to the instrument via VEGACONNECT. Start PACTware and provide connection to the sensor, e.g. via the VEGA project assistant. Close the parameter window of the sensor, as far as open.

Load software into sensor

Go in the PACTware menu bar to "*Instrument data*", "*Additional functions*" and "*Update instrument software*".

PACTware now checks the actual hardware and software version of the sensor and displays the data. This procedure lasts approx. 60 s.

Push the button "**Update software**" and select the previously extracted hex file. Then the software update can be started. The additional files are installed automatically. Depending on the sensor, this procedure can last approximately 1 h.

8.6 Instrument repair

If a repair is necessary, please proceed as follows:

You can download a return form (23 KB) from our Internet homepage www.vega.com under: "*Downloads - Forms and certificates - Repair form*".

By doing this you help us carry out the repair quickly and without having to call back for needed information.

- Print and fill out one form per instrument
- Clean the instrument and pack it damage-proof
- Attach the completed form and, if need be, also a safety data sheet outside on the packaging
- Please ask the agency serving you for the address of your return shipment. You can find the respective agency on our website www.vega.com under: "*Company - VEGA worldwide*"

Return of rod versions

On instruments with exchangeable rod, the rod must be unscrewed for transport to avoid damages.

Return the parts separately for repair.

To loosen to rod, you require a fork spanner with wrench size 8.

- 1 Loosen the rod with a fork spanner (SW 8) applied to the flat surfaces, provide counterforce with another fork spanner (SW 8)
- 2 Twist off the loosened rod manually

See also chapter "*Maintenance and fault rectification*" / "*Exchange cable/rod*"

9 Dismounting

9.1 Dismounting steps

**Warning:**

Before dismounting, be aware of dangerous process conditions such as e.g. pressure in the vessel, high temperatures, corrosive or toxic products etc.

Take note of chapters "*Mounting*" and "*Connecting to power supply*" and carry out the listed steps in reverse order.

9.2 Disposal

The instrument consists of materials which can be recycled by specialised recycling companies. We use recyclable materials and have designed the electronics to be easily separable.

WEEE directive 2002/96/EG

This instrument is not subject to the WEEE directive 2002/96/EG and the respective national laws. Pass the instrument directly on to a specialised recycling company and do not use the municipal collecting points. These may be used only for privately used products according to the WEEE directive.

Correct disposal avoids negative effects to persons and environment and ensures recycling of useful raw materials.

Materials: see chapter "*Technical data*"

If you have no way to dispose of the old instrument properly, please contact us concerning return and disposal.

10 Supplement

10.1 Technical data

General data

Material 316L corresponds to 1.4404 or 1.4435

Materials, wetted parts

– Process fitting	316L and PTFE, Hastelloy C22 (2.4602) and PTFE
– Process seal on the instrument side (cable/rod leadthrough)	FKM (Viton), FFKM (Kalrez 6375), EPDM, silicone FEP coated
– Process seal	On site (instruments with thread: Klingersil C-4400 is attached)
– inner conductor (up to the separation cable/rod)	318 S13 (1.4462)
– Rod: \varnothing 16 mm (0.63 in)	316L, Hastelloy C22 (2.4602)
– Cable: \varnothing 6 mm (0.236 in)	316 (1.4401)
– Gravity weight (optionally available)	316L

Materials, non-wetted parts

– Plastic housing	plastic PBT (Polyester)
– Aluminium die-casting housing	Aluminium die-casting AlSi10Mg, powder-coated - basis: Polyester
– Stainless steel housing - precision casting	316L
– Stainless steel housing, electropolished	316L
– Seal between housing and housing cover	NBR (stainless steel housing, investment casting), silicone (Aluminium/plastic housing, stainless steel housing, electro-polished)
– Inspection window in housing cover (optional)	Polycarbonate
– Ground terminal	316L

Process fittings

– Pipe thread, cylindrical (DIN 3852-A)	G $\frac{3}{4}$ A, G1 A, G1 $\frac{1}{2}$ A
– American pipe thread, conical (ASME B1.20.1)	$\frac{3}{4}$ NPT, 1 NPT, 1 $\frac{1}{2}$ NPT
– Flanges	DIN from DN 25, ANSI from 1"

Weight

– Instrument weight (depending on process fitting)	approx. 0.8 ... 8 kg (0.176 ... 17.64 lbs)
– Rod: \varnothing 16 mm (0.63 in)	approx. 1600 g/m (17 oz/ft)
– Cable: \varnothing 6 mm (0.236 in)	approx. 170 g/m (1.8 oz/ft)
– Gravity weight	730 g (26 oz)

Probe length L (from seal surface)

– Rod: \varnothing 16 mm (0.63 in)	up to 6 m (19.69 ft)
--------------------------------------	----------------------

- Trimming accuracy - rod	< 1 mm (0.039 in)
- Cable: \varnothing 6 mm (0.236 in)	up to 60 m (196.9 ft)
- Trimming accuracy - cable	± 0.05 %
Lateral load with rod: \varnothing 16 mm (0.63 in)	30 Nm (22 lbf ft)
Max. tensile load with cable: \varnothing 6 mm (0.236 in)	30 KN (6745 lbf)
Thread in gravity weight (cable version)	M 12

Input variable

Measured variable	Level of liquids and solids
Min. dielectric figure of the medium	$\epsilon_r > 1.6$

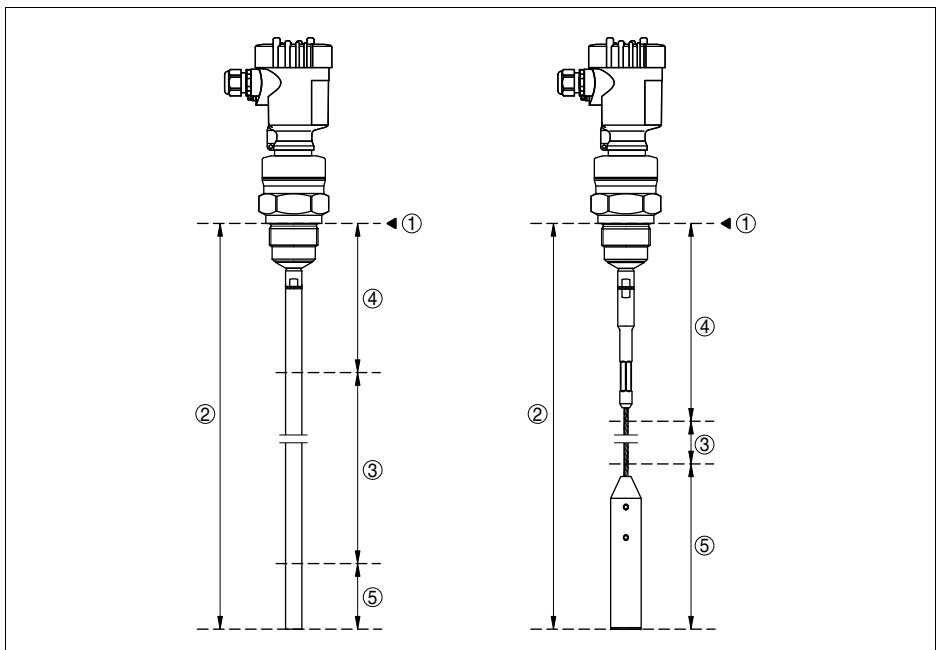

Fig. 29: Measuring ranges of VEGAFLEX 62

- 1 Reference plane
- 2 Probe length L
- 3 Measuring range (default setting refers to the measuring range in water)
- 4 Upper dead band (see diagrams under Accuracy - grey section)
- 5 Lower dead band (see diagrams under Accuracy - grey section)

Output variable

Output signal	4 ... 20 mA/HART
Cycle time	min. 1 s (dependent on the parameter setting)
Signal resolution	1.6 μ A

Failure signal current output (adjustable)	mA value unchanged 20.5 mA, 22 mA, < 3.6 mA (adjustable)
Max. output current	22 mA
Load	see load diagram under Power supply
Damping (63 % of the input variable)	0 ... 999 s, adjustable
Fulfilled NAMUR recommendations	NE 43
HART output values	
– 1. HART value (Primary Value)	Distance to the level
– 2. HART value (Secondary Value)	Distance to the level - scaled (for example hl, %)
Resolution, digital	> 1 mm (0.039 in)

Accuracy (similar to DIN EN 60770-1)

Process reference conditions according to DIN EN 61298-1

– Temperature	+18 ... +30 °C (+64 ... +86 °F)
– Relative humidity	45 ... 75 %
– Air pressure	+860 ... +1060 mbar/+86 ... +106 kPa (+12.5 ... +15.4 psig)

Installation reference conditions

– Min. distance to installations	> 500 mm (19.69 in)
– Vessel	metallic, ø 1 m (3.281 ft), centric installation, process fitting flush with the vessel ceiling
– Medium	Water/Oil (Dk value ~2.0)
– Installation	Probe end does not touch the vessel bottom

Sensor parameter adjustment

Gating out of false signals carried out
In bulk solids applications, implementing a false signal suppression is generally not recommended. The accuracy of bulk solid applications depends considerably on the application. Hard and fast accuracy specifications are thus not available.

Deviation

see diagrams
Depending on the installation conditions, there can be deviations which can be rectified with an adaptation of the adjustment or a change of the measured value offset in the DTM service mode.

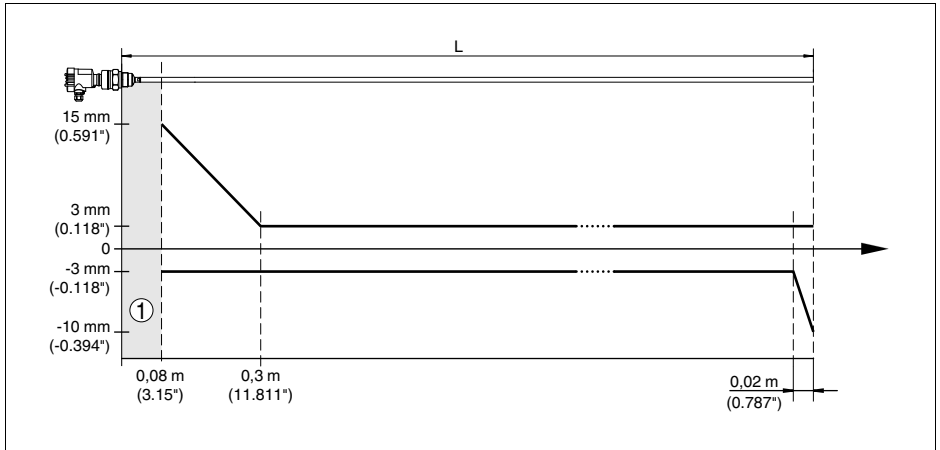

Fig. 30: Deviation VEGAFLEX 62 in rod version in water

- 1 Dead zone - no measurement possible in this area
- L Probe length

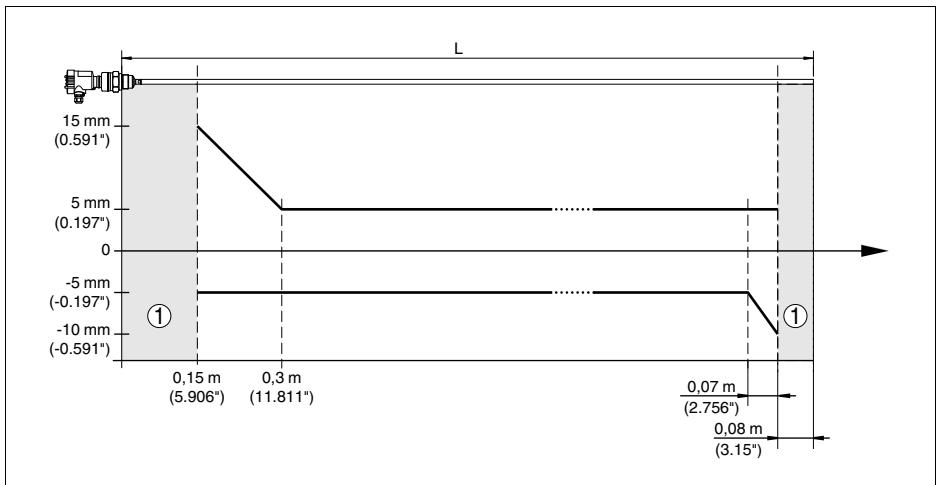

Fig. 31: Deviation VEGAFLEX 62 in rod version in oil

- 1 Dead zone - no measurement possible in this area
- L Probe length

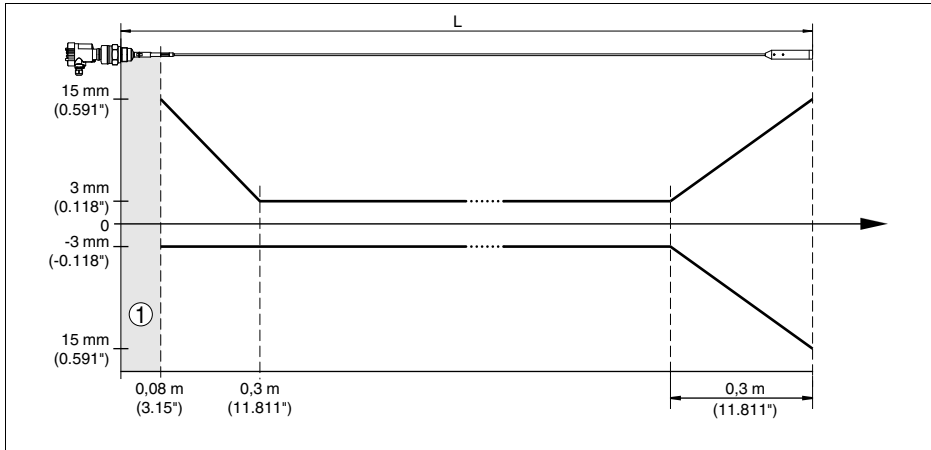

Fig. 32: Deviation VEGAFLEX 62 in cable version, probe length $L < 20$ m in water

- 1 Dead zone - no measurement possible in this area
 L Probe length

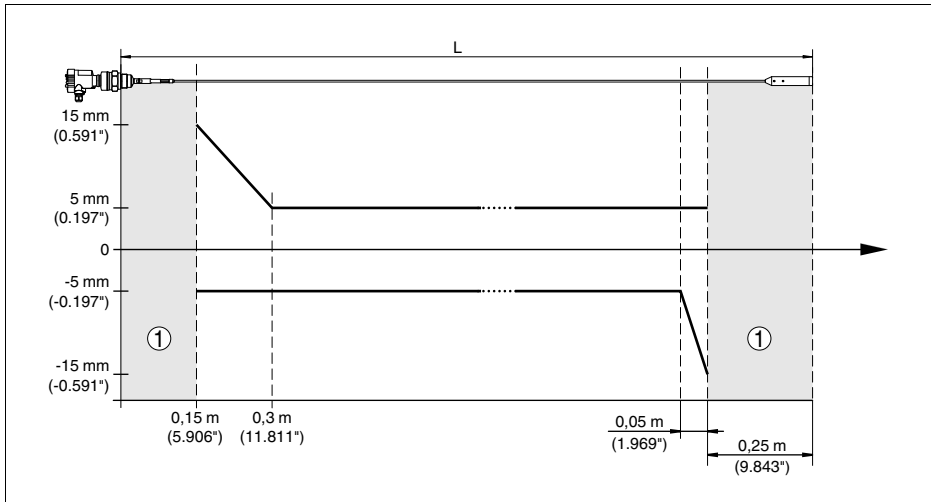

Fig. 33: Deviation VEGAFLEX 62 in cable version, probe length $L < 20$ m in oil

- 1 Dead zone - no measurement possible in this area
 L Probe length

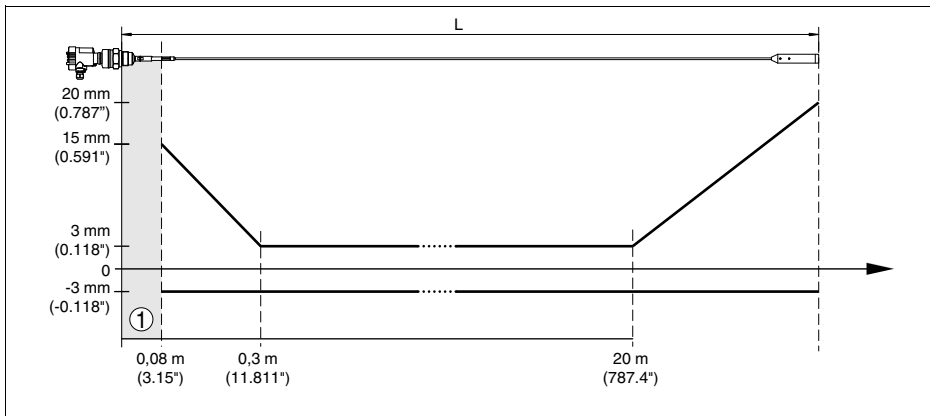

Fig. 34: Deviation VEGAFLEX 62 in cable version, probe length $L > 20$ m in water

1 Dead zone - no measurement possible in this area

L Probe length

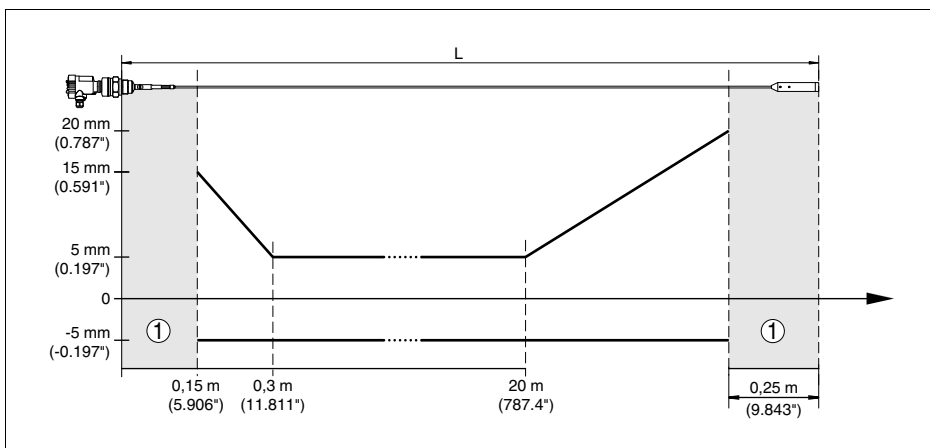

Fig. 35: Deviation VEGAFLEX 62 in cable version, probe length $L > 20$ m in oil

1 Dead zone - no measurement possible in this area

L Probe length

Influence of the ambient temperature to the sensor electronics

Temperature drift	0.03 %/10 K relating to the max. measuring range or max. 0.3 %
Temperature drift - Digital output	3 mm/10 K relating to the max. measuring range or max. 10 mm

Ambient conditions

Ambient, storage and transport temperature -40 ... +80 °C (-40 ... +176 °F)

Process conditions

Process pressure -1 ... +40 bar/-100 ... +4000 kPa (-14.5 ... +580 psig), depending on the process fitting

Process temperature (thread or flange temperature)

- FKM (Viton) -40 ... +150 °C (-40 ... +302 °F)
- EPDM -40 ... +150 °C (-40 ... +302 °F)
- FFKM (Kalrez 6375) -20 ... +150 °C (-4 ... +302 °F)

The measurement error from the process conditions is in the specified pressure and temperature range of below 1 %.

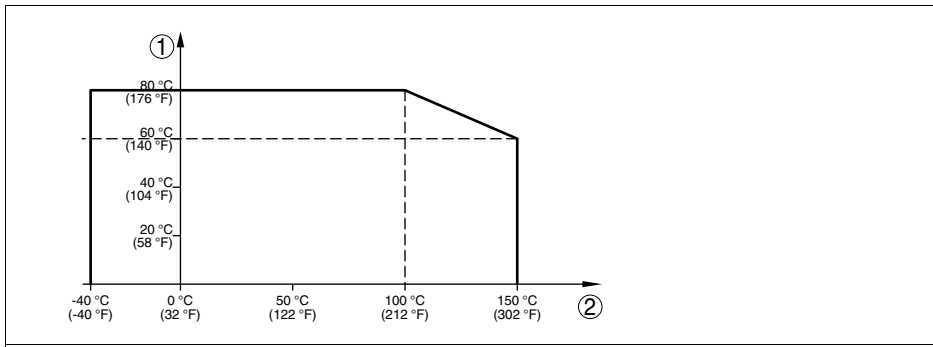

Fig. 36: Ambient temperature - Process temperature

- 1 Ambient temperature
- 2 Process temperature (depending on the seal material)

Electromechanical data - version IP 66/IP 67 and IP 66/IP 68; 0.2 bar

Cable entry/plug³⁾

- Single chamber housing
 - 1 x cable gland M20 x 1.5 (cable: \varnothing 5 ... 9 mm), 1 x blind stopper M20 x 1.5
 - or:
 - 1 x closing cap M20 x 1.5; 1 x blind stopper M20 x 1.5
 - or:
 - 1 x closing cap ½ NPT, 1 x blind plug ½ NPT
 - or:
 - 1 x plug (depending on the version), 1 x blind stopper M20 x 1.5

³⁾ Depending on the version M12 x 1, according to DIN 43650, Harting, 7/8" FF.

- Double chamber housing
 - 1 x cable entry M20 x 1.5 (cable: \varnothing 5 ... 9 mm), 1 x blind stopper M20 x 1.5; 1 x blind stopper M16 x 1.5 or optionally available with 1 x plug M12 x 1 for VEGADIS 61
 - or:
 - 1 x closing cap ½ NPT, 1 x blind stopper ½ NPT, 1 x blind stopper M16 x 1.5 or optionally 1 x plug M12 x 1 for VEGADIS 61
 - or:
 - 1 x plug (depending on the version), 1 x blind stopper M20 x 1.5; 1 x blind stopper M16 x 1.5 or optionally available with 1 x plug M12 x 1 for VEGADIS 61
- Spring-loaded terminals for wire cross-section > 2.5 mm² (AWG 14)

Electromechanical data - version IP 66/IP 68 (1 bar)

Cable entry

- Single chamber housing 1 x IP 68 cable gland M20 x 1.5; 1 x blind stopper M20 x 1.5
- Double chamber housing 1 x IP 68 cable gland M20 x 1.5; 1 x blind stopper M20 x 1.5; 1 x blind stopper M16 x 1.5

Connection cable

- Wire cross-section 0.5 mm² (AWG 20)
- Wire resistance < 0.036 Ω /m
- Tensile strength < 1200 N (270 lbf)
- Standard length 5 m (16.4 ft)
- Max. length 1000 m (3280 ft)
- Min. bending radius 25 mm (0.984 in) with 25 °C (77 °F)
- Diameter approx. 8 mm (0.315 in)
- Colour - standard PE Black
- Colour - standard PUR Blue
- Colour - Ex-version Blue

Indicating and adjustment module

- Voltage supply and data transmission through the sensor
- Indication LC display in dot matrix
- Adjustment elements 4 keys
- Protection rating
 - unassembled IP 20
 - mounted into the sensor without cover IP 40
- Materials
 - Housing ABS

- Inspection window Polyester foil

Voltage supply

Operating voltage

- Non-Ex instrument 14 ... 36 V DC
- EEx-ia instrument 14 ... 30 V DC
- EEx-d-ia instrument 20 ... 36 V DC

Operating voltage with lighted indicating and adjustment module

- Non-Ex instrument 20 ... 36 V DC
- EEx-ia instrument 20 ... 30 V DC
- EEx-d-ia instrument 20 ... 36 V DC

Permissible residual ripple

- < 100 Hz $U_{ss} < 1 \text{ V}$
- 100 Hz ... 10 kHz $U_{ss} < 10 \text{ mV}$

Load

see diagram

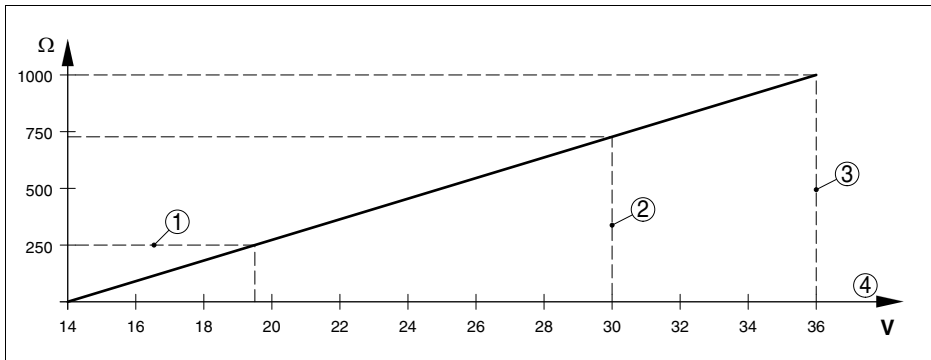

Fig. 37: Voltage diagram

- 1 HART load
- 2 Voltage limit EEx-ia instrument
- 3 Voltage limit non-Ex/Ex-d instrument
- 4 Operating voltage

Electrical protective measures

Protection, depending on housing version

- Plastic housing IP 66/IP 67
- Aluminium housing, stainless steel housing - investment casting, stainless steel housing - electro-polished IP 66/IP 68 (0.2 bar)⁴⁾
- Aluminium and stainless housing, investment casting (optionally available) IP 66/IP 68 (1 bar)

⁴⁾ A suitable cable is the prerequisite for maintaining the protection rating.

Overvoltage category	III
Protection class	II

Functional safety (SIL)

Functional safety is already activated on instruments with SIL qualification ex factory. On instruments without SIL qualification ex factory, the functional safety must be activated by the user via the indicating and adjustment module or via PACTware for applications according to SIL.

Functional safety according to IEC 61508-4

- Single channel architecture (1oo1D) up to SIL2
- double channel diversitary redundant architecture (1oo2D) up to SIL3

You can find detailed information in the supplied Safety Manual of the instrument series or under "www.vega.com", "*Downloads*", "*Approvals*".

Approvals

Depending on the version, instruments with approvals can have different technical data.

For these instruments, the corresponding approval documents have to be taken into account. These are part of the delivery or can be downloaded under www.vega.com via "*VEGA Tools*" and "*serial number search*" as well as via "*Downloads*" and "*Approvals*".

10.2 Dimensions

The following dimensional drawings represent only an extract of the possible versions. Detailed dimensional drawings can be downloaded on www.vega.com under "Downloads" and "Drawings".

Plastic housing

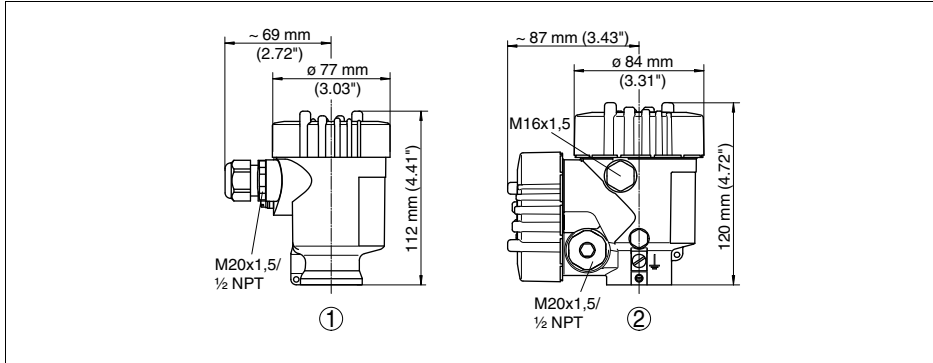

- 1 Single chamber version
- 2 Double chamber version

Aluminium housing

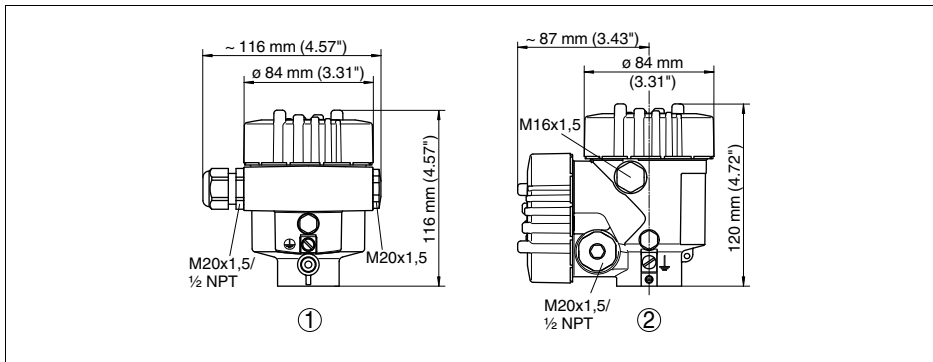

- 1 Single chamber version
- 2 Double chamber version

Aluminium housing in protection rating IP 66/IP 68, 1 bar

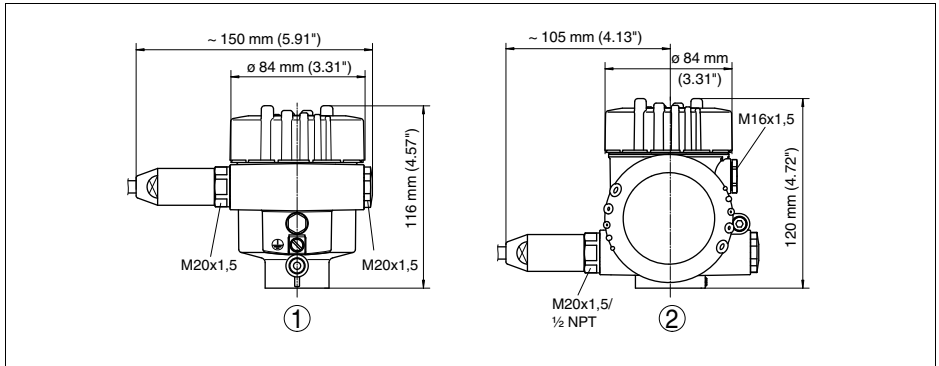

- 1 Single chamber version
- 2 Double chamber version

Stainless steel housing

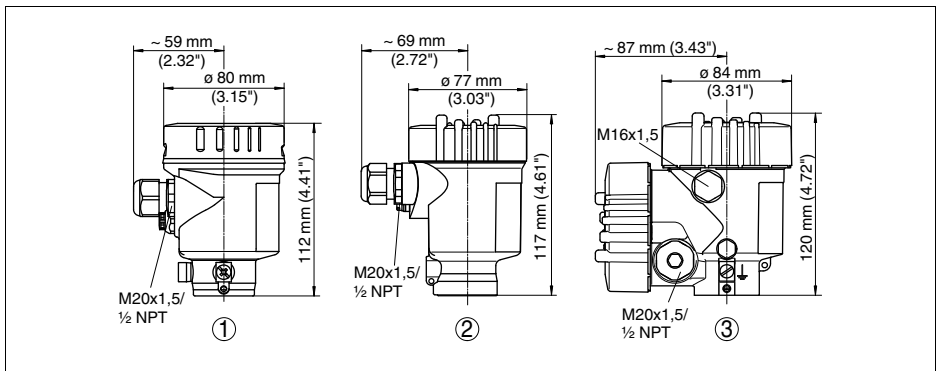

- 1 Single chamber version, electropolished
- 2 Single chamber version, precision casting
- 2 Double chamber version, precision casting

VEGAFLEX 62

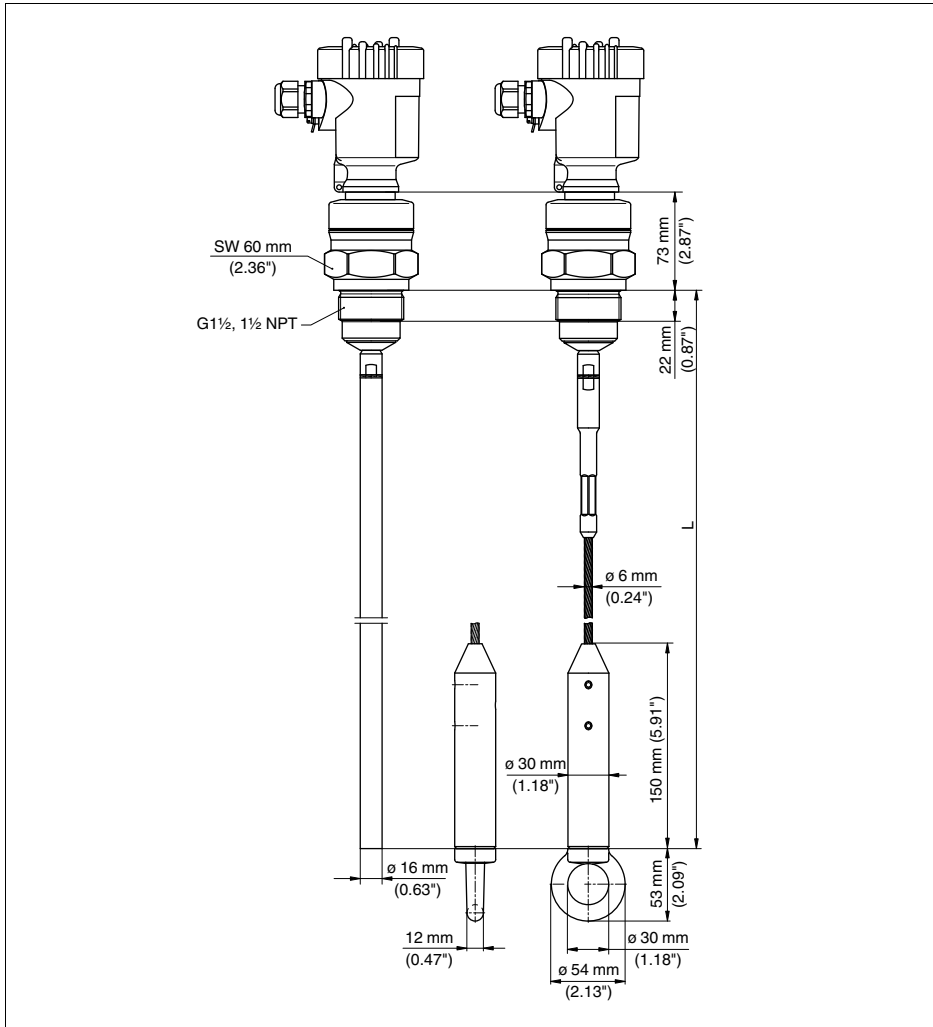

Fig. 42: VEGAFLEX 62

L Sensor length, see chapter "Technical data"
Lug optionally

10.3 Industrial property rights

VEGA product lines are global protected by industrial property rights.
Further information see <http://www.vega.com>.

Only in U.S.A.: Further information see patent label at the sensor housing.

VEGA Produktfamilien sind weltweit geschützt durch gewerbliche Schutzrechte.

Nähere Informationen unter <http://www.vega.com>.

Les lignes de produits VEGA sont globalement protégées par des droits de propriété intellectuelle.

Pour plus d'informations, on pourra se référer au site <http://www.vega.com>.

VEGA líneas de productos están protegidas por los derechos en el campo de la propiedad industrial.

Para mayor información revise la pagina web <http://www.vega.com>.

Линии продукции фирмы ВЕГА защищаются по всему миру правами на интеллектуальную собственность.

Дальнейшую информацию смотрите на сайте <http://www.vega.com>.

VEGA系列产品在全球享有知识产权保护。

进一步信息请参见网站<<http://www.vega.com>>。

10.4 Trademark

All brand names as well as trade and company names used are property of their lawful proprietor/originator.



Printing date:

VEGA Grieshaber KG
Am Hohenstein 113
77761 Schiltach
Germany
Phone +49 7836 50-0
Fax +49 7836 50-201
E-mail: info@de.vega.com
www.vega.com



All statements concerning scope of delivery, application, practical use and operating conditions of the sensors and processing systems correspond to the information available at the time of printing.

© VEGA Grieshaber KG, Schiltach/Germany 2010