

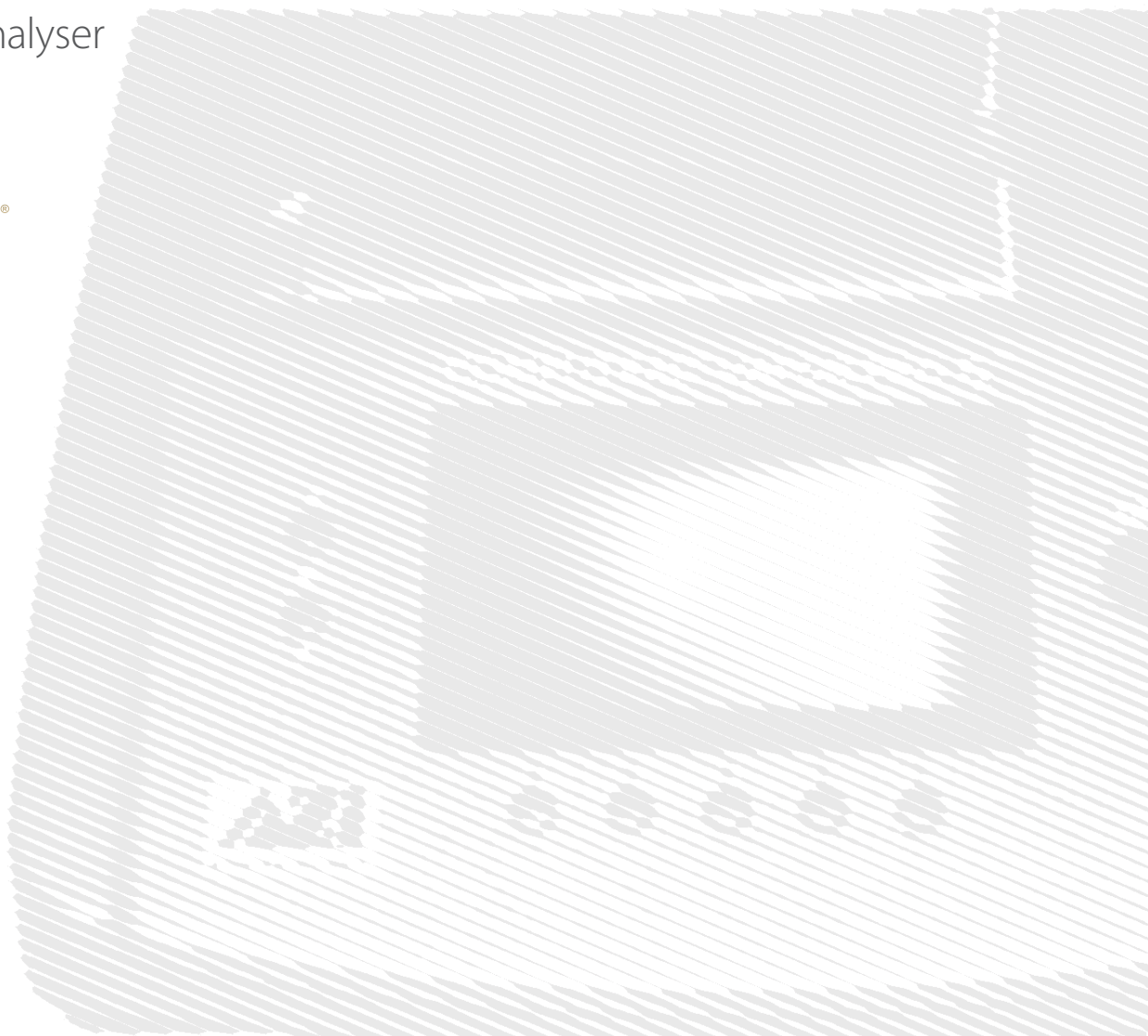

Installation & Maintenance Instructions

Computrac[®] Vapor Pro[®] Fx

Moisture Analyser



Computrac[®] VAPOR PRO[®] Fx
PROPRIETARY RIGHTS NOTICE

The material in this manual contains valuable information developed by Arizona Instrument LLC for use with the Computrac[®] line of moisture analyzers. No part of this manual can be reproduced or transmitted in any form or by any means, electronic, mechanical, or otherwise. This includes photocopying and recording or in connection with any information storage or retrieval system without the express written permission of Arizona Instrument LLC.

ALL RIGHTS RESERVED

TABLE OF CONTENTS

1.	WARNINGS AND SAFETY INFORMATION	4
2.	INTRODUCTION	6
3.	PRINCIPLES OF OPERATION	7
4.	UNPACKING	8
5.	INSTALLATION	9
5.1.	EXTERNAL CONNECTIONS	9
5.2.	POWER ON CHECKS	13
5.2.1.	CHECK SENSOR STATUS	13
5.2.2.	DRYNESS TEST	14
6.	RH SENSOR CALIBRATION	15
6.1.	SYRINGE TECHNIQUE	15
6.2.	CALIBRATION CHECK	17
6.3.	SENSOR CALIBRATION	19
7.	TEMPERATURE CALIBRATION	21
8.	RUNNING MOISTURE TESTS	23
8.1.	SELECT TEST SETTINGS	23
8.1.1.	ENTER MATERIAL NAME	23
8.1.2.	SET PROGRAMMED TEST TEMPERATURE	24
8.1.3.	SELECT UNITS FOR THE FINAL RESULT DISPLAY	24
8.1.4.	SELECT HOW TO END THE TEST	25
8.1.5.	SELECT SAMPLE WEIGHT ENTRY MODE	25
8.1.6.	SET SYRINGE FEED TIME	26
8.1.7.	CORRELATION FACTOR	26
8.1.8.	DETERMINE SAMPLE SIZE	26
8.2.	RUN MOISTURE TEST with 5cc Syringe	28
9.	MENU SYSTEM	30
9.1.	MEMORY START MENU	32
9.2.	STORED DATA MENU	32
9.3.	CALIBRATION MENU	33
9.4.	SETUP MENU	34
9.5.	DIAGNOSTIC MENU	36
10.	CONDITION PROMPTS AND SYSTEM FAILURE CODES	37
10.1.	CONDITION PROMPTS	37
10.2.	SYSTEM FAILURE CODES	38
11.	COMMONLY ASKED QUESTIONS	39
12.	REPAIR AND MAINTENANCE	43
12.1.	ACCESS COVER REMOVAL	43
12.2.	INSTRUMENT COVER REMOVAL	44
12.3.	REMOVAL OF AIR TUBE, SENSOR BLOCK TO COIL	45
12.4.	REPLACING THE CALIBRATION PORT SEPTUM	46
12.5.	REPLACING THE SAMPLE PORT SEPTUM	47
12.6.	HEATER COIL ASSEMBLY CLEANING	48
12.7.	LEAK CHECK THE SYSTEM	50
12.8.	FLOW RATE	51
13.	APPENDIX A - AZI ZSP150/SP150 OR SCI SA800 DIGITAL BALANCE	52
14.	APPENDIX B - SPECIFICATIONS AND RATINGS	54
15.	WARRANTY	55

An updated electronic copy of this manual is available at www.azic.com.

1. WARNINGS AND SAFETY INFORMATION

The VP-Series Moisture Analyzers comply with the Underwriter Laboratories Inc. standards and European Council Directives for Electrical Equipment for Laboratory Use, electromagnetic compatibility, and the stipulated safety requirements. However, improper use or handling of instrument can result in damage to equipment and/or injury to personnel.

The VP-Series Moisture Analyzers are identified as Equipment Class I, Pollution Degree 2, and Installation Category II.

Read this manual thoroughly before using your moisture analyzer to prevent damage to the equipment. Keep these instructions in a safe place. An up-to-date electronic copy of this manual can be found at the AZI web site at <http://www.azic.com> then click on "Downloads".

The following instructions will help to ensure safe and trouble-free operation of your moisture analyzer.

- Use the moisture analyzer only for performing moisture analysis of samples. Any improper use of the analyzer can endanger persons and may result in damage to the analyzer or other material assets.
- Do not use this moisture analyzer in a hazardous area/location; operate it only under the ambient conditions specified in these instructions.
- Although the moisture analyzer is simple to operate and is very user friendly, it should only be operated by qualified persons who are familiar with the properties of the sample being analyzed.
- Ensure, before getting started, that the voltage rating printed on the manufacturer's label is identical to your local line voltage (see the section beginning on page 9.)
- The VP-Series Moisture Analyzer is provided with a power cord that has a protective grounding conductor. Do not operate the unit without the supplied three-wire power cord or an identical recognized equivalent that meets all applicable standards.
- AZI does not recommend the use of an extension cord. However, if one must be used, use an extension cord that meets all applicable standards and has a protective grounding conductor.
- Do not remove the protective grounding wire from the power supply circuit.
- With the power switch off, power is still applied to the power entry module. Disconnect the power cord from the instrument to ensure complete power removal.
- Position the power cable so that it cannot touch any hot areas of the moisture analyzer.
- Use only AZI supplied accessories and options with VP-Series Moisture Analyzers or check with AZI before using

any third party accessories, such as printers and analytical balances, to verify compatibility.

- If there is visible damage to the VP-Series Moisture Analyzer or its power cord, unplug and isolate the unit first and then call Customer Service.
- Do not open the analyzer housing of the VP-Series Moisture Analyzer. There are no user serviceable parts or adjustments inside the unit. Any maintenance inside the unit is to be performed by factory-trained technicians only. Any unauthorized inspection and/or maintenance of the VP-Series Moisture Analyzer will void the warranty.

Prevent excess heat build-up around the analyzer

- When setting up the moisture analyzer, leave enough space to prevent heat from building up and to keep your analyzer from overheating. Leave 20 cm (about 8 inches) around the moisture analyzer and 1 meter (about 3 ft.) above the unit.
- Do not put any flammable substances on, under or near the right side of the moisture analyzer. The area around the heated coil will heat up.
- Use extreme care when handling the discharge from the instrument. Although the liquids may cool rapidly, they will still be very hot at the liquid outlet and drain tube.

HAZARDS FOR PERSONS OR EQUIPMENT POSED BY USING SPECIFIC SAMPLES: Flammables; explosives; substances that contain flammables, explosives, solvents; and/or substances that release flammable or explosive gases or vapors during the drying process.

- If flammable or explosive liquids are tested, the gasses escaping through the back of the unit are still dangerous when they are exposed to the atmosphere. Fume hoods may offer partial protection but the potential danger will still be present. The user shall be liable and responsible for any damage that arises in connection with the VP-Series Moisture Analyzers and potentially harmful substances.
- Do not test liquids with a boiling point at or below 70 °C (158 °F)
- Substances containing toxic, caustic or corrosive substances may be analyzed with the unit in an appropriate fume hood only. The fume hood must keep the work area below the lower toxic limit established by appropriate standards.
- Substances that release caustic vapors such as acids should be analyzed in the smallest sample size possible to still achieve satisfactory results. If vapors condense on the VP-Series Moisture Analyzers housing parts, stop the testing, wipe the surface clean with a suitable neutralizer

and place the unit in a fume hood capable of removing the vapors. The heated coil in the instrument is stainless steel but other portions of the flow system are aluminum. Check for compatibility of substances to be tested before injecting them into the instrument.

- The user has the responsibility for carrying out appropriate decontamination if hazardous material is spilt on or inside the VP-Series Moisture Analyzers.

CLEANING

- Clean the VP-Series Moisture Analyzers according to the cleaning instructions only. Use of strong detergents and “oven cleaners” will damage the case and heater housing.
- Before using any cleaning or decontamination method except those recommended by Arizona Instrument, check with AZI Customer Service at 1-602-470-1414 or 1-800-528-7411, to ensure that the proposed method will not damage the equipment.
- The outside housing of the VP-Series Moisture Analyzers should be cleaned with a mild household detergent such as “409” and a soft, lint-free cloth. Paper towels should never be used, as they will scratch the instrument’s finish and the clear lens over the display. If methods that are more stringent are required, call AZI Customer Service at 1-602-470-1414 or 1-800-528-7411 for recommendations.
- Isopropyl Alcohol is used to clean the heated coil and discharge components under normal circumstances. Follow the directions contained in this manual beginning on page 48.
- Every precaution has been taken to prevent contaminants from entering the unit. However, if liquids or powders do enter the case, call AZI Customer Service at 1-602-470-1414 or 1-800-528-7411 for recommendations.

The user shall be liable and responsible for any damage that arises in connection with the use this moisture analyzer.

ENVIRONMENTAL CONDITIONS

Storage and Shipping

- Temperature should be between 0 °C to +40 °C (+32 °F to +104 °F).
- Relative Humidity should be between 10% and 80%.

OPERATIONAL CONDITIONS – INDOOR USE.

- Optimum results will be achieved when the unit is set on a smooth, level, and vibration free surface in a non-condensing, non-explosive environment of 0-40 °C @ 50% relative humidity and 0-31 °C @ 80% relative humidity.
- Do not expose the moisture analyzer unnecessarily to extreme temperatures, moisture, shocks, blows or vibration.

UNPACKING THE MOISTURE ANALYZER

- After unpacking the moisture analyzer, check it immediately for any visible damage as a result of rough handling during shipment.
- Save the box and all parts of the packaging to use when returning your moisture analyzer for calibration. Only the original packaging provides the AZI recommended protection for shipment. Before packing your moisture analyzer for shipment, unplug all connected cables to prevent damage during transit.

WARNING SYMBOLS



- Protective Ground

Identifies the connection on the Chassis and Power Inlet Module for connection of the safety ground (green/yellow) wire.



- Warning

Information or procedure that must be observed.



- Electrical Shock Hazard.

Observe all steps of the procedure to prevent electrical shock.



- Warning, Hot surface or area of possible severe burns.

Use listed precautions when using the instrument and handling samples to prevent injury.

2. INTRODUCTION

Arizona Instrument is proud to continue its leadership role in the development of new technology in the moisture analysis industry.

A revolutionary moisture analyzer with a detection limit of 10 ppm, the Computrac[®] **VAPOR PRO[®] Fx** uses a sensor-based technology and correlates to the Karl Fischer coulometric titration method (with an oven attachment) in precision and accuracy. The analyzer does not utilize reagents, minimizes consumables, and is simple to operate.

Principles of Operation: The Computrac[®] **VAPOR PRO[®] Fx** injects a sample of test material into a coiled tube heater. Evolved volatiles are picked up by a dry airflow system and passed to an analysis cell where the moisture content is measured. A microprocessor integrates the varying moisture signal and converts the signal to micrograms of water for display. Results are available in parts per million, percent moisture, or total micrograms of water. The heating range of the instrument is 25 °C to 200 °C. Test parameters such as sample size, heater temperature, ending test criteria, and syringe feed time can be altered to optimize speed and accuracy.

Performance: Designed for either lab or production floor use, the Computrac[®] **VAPOR PRO[®] Fx** uses patented, state-of-the-art technology specifically designed to provide accurate and precise results in a timely manner. This ensures that product quality is achieved and maintained.

The Computrac[®] **VAPOR PRO[®] Fx** stores up to 102 programmed memory settings for materials and retains the data from the last 30 sample test runs. The software automatically calculates the statistics of any selected stored data upon demand. All retained test data can be automatically sent to an external printer or personal computer at the end of a test or on request.

A factory-calibrated syringe provided in the accessory kit permits quick and easy system verification. System calibration is checked in just minutes using the calibrated syringe and de-ionized or distilled water. Re-calibration is a menu driven procedure to assure accurate and reliable results day after day. Built-in self-diagnostics constantly monitor system conditions to detect and report any abnormalities in the hardware, software, moisture sensor, or flow system.

3. PRINCIPLES OF OPERATION

The Computrac® VAPOR PRO® Fx utilizes a coiled tube heater, a controlled sample injection system, a dry airflow system, and a moisture sensor. The instrument injects a metered flow of a liquid sample into the heated tube. Volatiles driven off from the sample are picked up by the dry air and passed to a sensor block containing the relative humidity (RH) sensor, where the evolved moisture is measured. The moisture data, along with control parameters, are input to a microprocessor where the collected data are converted into an accurately displayed indication of the moisture content in the sample. The instrument then displays the result in terms of:

- Parts per million (ppm) H₂O,
- Micrograms (µg) H₂O, or
- Percentage (%) H₂O.

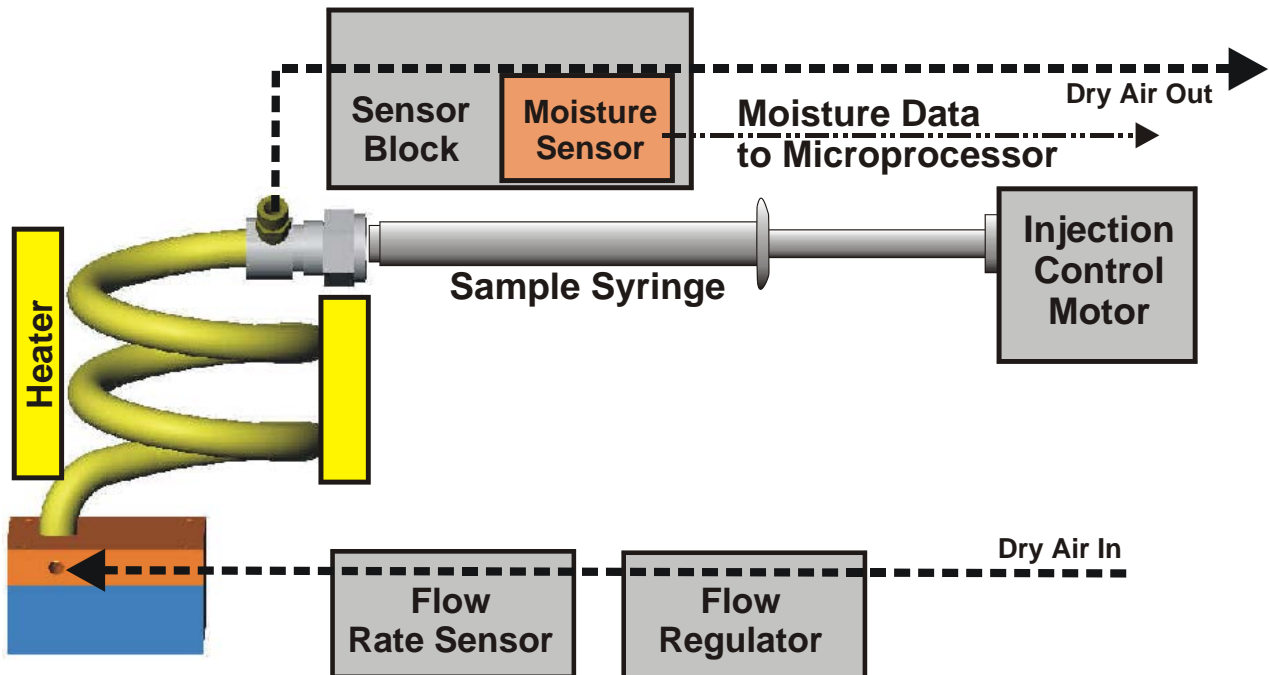

The moisture sensor used to detect water in the dry air stream is a polymer capacitor relative humidity sensor. The reading from this sensor is combined with sensor block temperature and outlet flow rate to determine absolute micrograms of water per second.

Test parameters such as temperature, ending criteria, and sample weight entry can be changed to optimize test accuracy. See Appendix B, beginning on page 54, for detailed specifications and operating limits.

4. UNPACKING

Unpack the instrument and locate the following items:

ITEM	AZI PART NUMBER
Computrac® VAPOR PRO® Fx	CT-4100-L CT-4100-L220V
Accessory Kit:	Y990-0152
1 Power Cord (varies with area)	200-0002 200-0003 200-0008 US/Canada England Europe
2 #18 X 1.5" Needle, Luer Fitting use with Glass Syringe for sample testing	300-0396
2 #18 X 2.0" Needle, Luer Fitting use with Plastic Syringe for sample testing	300-0440
1 #22 X 2.0" Needle, Luer Fitting use with Plastic Syringe for heater coil cleaning	300-0466
4.5' Clear Tubing, 1/8" X 1/4"	345-0050
1 5cc Glass Syringe	990-0122
10 5cc Disposable Syringe	2600 1012
1 1.0 µl Hamilton Syringe (1)	990-0068
1 Adaptor, 1cc Syringe	300-0559
1 Set screw for Syringe adaptor	300-0560
10 1 ml Syringe – (for use with 1cc adaptor)	990-0203
1 Waste Jar Assembly	990-0200
1 Grease for Waste Jar	PS-557
10 Septa, Injection Port	990-0058
1 20 ml Sample Bottle w/Septum and Cap	990-0153
10 Septa, Test Port	990-0132
1 Instrument Support Stand	990-0227
1 Desiccator Kit, Inline	Y990-0116

Optional items ordered separately:

Grommet for Waste Jar	355-0177
Wire Tie	PS-160
Septum (For 20 ml Sample Bottle)	990-0074
101 key PC keyboard	990-0088
PC graphics printer kit	Y990-0098
Digital balance with cable and Communications Software	Y990-0082
Travel case	990-0092
Temperature Calibration Kit with 9 VDC, 100mA, 3.5mm male plug, + tip, DC Adaptor	Y990-0142 (110 VAC) Y990-0165 (220 VAC)
Dry Air Generator Kit	Y990-0143
VAPOR PRO® Communications Package	Y990-0196

If you are unable to locate any of the standard items or have questions regarding the optional accessories, please contact AZI Customer Service by phone at 800-528-7411, 602-470-1414, or send e-mail to support@azic.com.

5. INSTALLATION

5.1. EXTERNAL CONNECTIONS

- Place the instrument on the support stand [AZI P/N 990-0227] included in the Accessory kit, as shown.
- Using 1/8" ID clear tubing [AZI P/N 345-0050], attach a dry nitrogen or dry carrier air source to the **Carrier Gas Inlet Port** on the back of the instrument. (Shown to the right of the fan)
 - Carrier gas source should be dry nitrogen but may be dried facility air or air from a dry air generator if the product under test is non-flammable and non-explosive.



- The pressure from the compressed gas cylinder is very high and is normally reduced by a two-stage regulator. The pressure from the compressed air or nitrogen system in most facilities will be at moderate pressure and normally require only a single stage regulator. The AZI dry air generator [AZI P/N Y990-0143] produces the pressure required by the instrument and no additional regulator is needed if the dry air generator is used.



Although designed for portable operation, the dry air generator should never be used with a potentially flammable or explosive product. Only dry nitrogen should be used with these products and all environmental considerations for safety observed.



- Examples of regulators capable of regulating pressure acceptably are as follows.
 - For cylinder applications:
 - › Multi-stage Gas Regulator for Compressed Air Cylinder, VWR #55850-474 or equivalent.

- For supplied gas sources:
 - Matheson Gas Products Model 3473 Series Single Stage Line Regulator or equivalent.
- Connecting tubing must be AZI P/N 345-0050 clear impermeable tubing, unless otherwise indicated, to prevent introducing moisture into the carrier gas system. Tubing size is 1/8" ID X 1/4" OD.
- A desiccant bed that removes moisture from the carrier gas is supplied with each instrument. As the following drawings illustrate, the desiccant is placed just before the inlet connection of the instrument. The desiccant turns from blue to pink as it absorbs moisture. When the entire column of desiccant is pink, it will no longer absorb moisture, and the desiccant must be replaced or regenerated to restore the drying capacity.
- Instructions on the Drierite® website tell how to regenerate the Drierite® for continued use. For further information, contact W.A. Hammond Drierite Co Ltd at (937) 376-2927 or at www.drierite.com.
- The following diagrams are not to scale but illustrate the preferred connecting arrangements.

- Cylinder with two-stage regulator is connected to the desiccator with clear tubing [AZI P/N 345-0050]. The desiccator is connected to the instrument with the same type of tubing. Pressure to the instrument is set to 12-20 psi.



- The facilities air or nitrogen supply is usually connected to a wall or bench mounted regulator. The regulator is connected to the desiccator with clear tubing [AZI P/N 345-0050]. The desiccator is connected to the instrument with the same type of tubing. Pressure to the instrument is set to 12-20 psi.



- The dry air generator, used for non-flammable, non-explosive products only, is connected to the desiccator with yellow tubing [AZI P/N 2500 3003]. The desiccator is connected to the instrument with clear tubing [AZI P/N 345-0050].

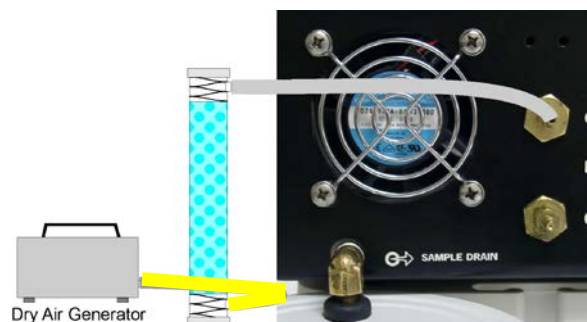

- Install a waste jar assembly [AZI P/N: 990-0200] on the marked SAMPLE DRAIN fitting as shown, by sliding the jar onto the fitting and then rotating the jar counterclockwise underneath the stand so it rests on the jar support platform. Removal is the reverse of installation. If necessary, use a screwdriver to loosen the two screws and adjust the height of the jar support platform. Ensure the drain fitting is tight and inserted into the waste jar grommet to a point just above the “MAX. FILL LINE” marked on the jar’s label. An airtight seal is required to accurately determine moisture in the product sample.



- The waste jar must be emptied or replaced before the maximum fill line level is exceeded. If the waste product residue blocks the drain port, a clog detector will sense the blockage and prevent instrument operation until the cause of the blockage is removed. Products that are solid at room temperature must be monitored as they will harden and block the waste outlet long before the jar is full. If the clog detector stops the instrument before the waste jar is full, and no obvious reason is seen, call AZI Customer Service at 800-528-7411 or 602-470-1414 for assistance.



- If you plan to use a printer, electronic balance, and/or computer connect them to the marked connectors at the back of the instrument. The accessory keyboard connects into a DIN connector on the side of the instrument. Connect all accessories while the instrument is turned OFF, and power ON the accessories before powering ON the instrument.
- Power control and fuses are located at the rear of unit. The power entry module must be configured for the voltage supplied to it. This will be either 100 to 120 VAC or 220 to 240 VAC. The unit is configured at the factory for the destination country at time of shipment. However, to ensure the unit is configured correctly, verify the arrow indicator on the fuse holder points to the proper voltage for your environment before connecting to a power source.



Voltage Indicator Arrow

- To change from 110 to 220VAC or from 220 to 110VAC:
 - Ensure the power switch, located next to the fuse holder, is in the off (O) position.
 - Remove the fuse holder from the power entry module by prying with a small flat screwdriver.
 - Change the fuse:
 - › A unit operating from 100-120 VAC should have two 8-amp slow blow fuses, (AZI P/N 190-1001).
 - › A unit operating from 200-240 VAC should have two 4-amp slow blow fuses, (AZI P/N 190-1002).
 - Turn the fuse holder around, and slide it back in so that the arrow indicator on the power entry module is pointing to the correct voltage for your environment.
- Remove the power cord from the packing material and insert the rectangular end into the power receptacle, located on the other side of the fuse holder. Never use any power cable other than the one provided or one of equivalent UL/CSA/CE recognized ratings



The power source outlet used by the **VAPOR PRO[®] Fx** **MUST BE GROUNDED**. (If you are not sure if the socket is grounded, check with your plant electrician before proceeding). **The VAPOR PRO[®] Fx will appear to function correctly even if the socket is not grounded, but there is a danger of possible electrocution! If grounded outlets are not available, consider using a ground fault interrupter to protect personnel against electrical shock.**



- Plug the line cord into its dedicated electrical power outlet. Line noise on the power lines may affect accuracy. A dedicated AC power line or an isolation transformer may be beneficial in eliminating this noise and increasing the accuracy of the moisture determination.
- Never cover the power receptacle so that the power cord cannot be removed quickly and easily.

5.2. POWER ON CHECKS

- Toggle the power switch at the rear of the unit to the ON (I) position.
- After a quick view of the instrument identification and the firmware version, the MAIN TEST SCREEN will appear.

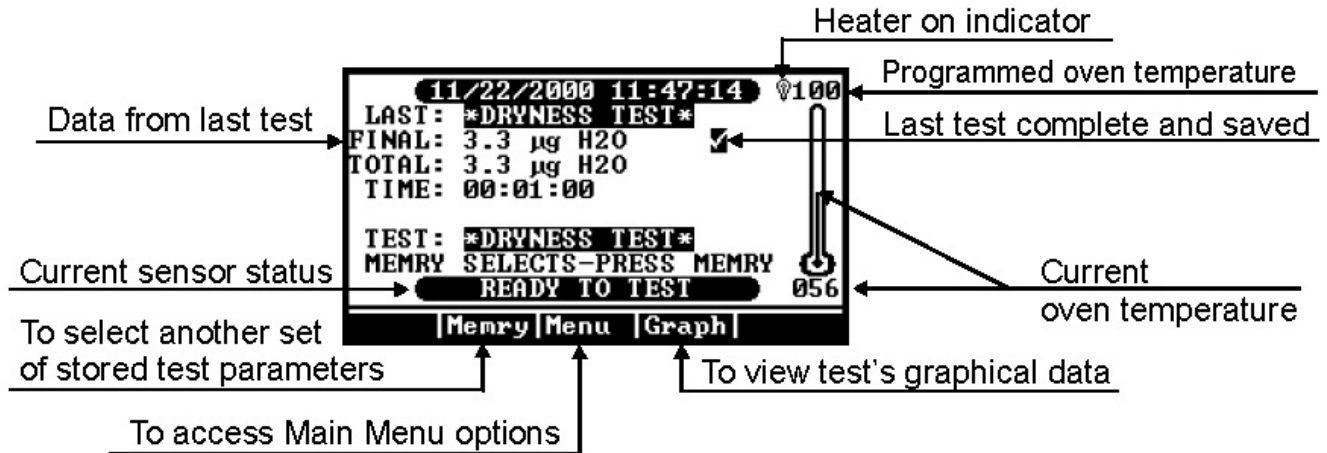

Main Test Screen

- Allow the instrument to warm-up for 20 minutes. The **VAPOR PRO® Fx** is designed to remain on at all times unless cleaning or other maintenance described in this manual is being performed. Therefore, a warm-up period should not be necessary before performing normal testing.

5.2.1. CHECK SENSOR STATUS

- From the MAIN TEST SCREEN, press [Menu] to reveal the MAIN MENU. Use the buttons below the display on the front panel to move through the menu screens and system settings.



Main Test Screen

- Move the cursor down to highlight the DIAGNOSTIC MENU.
- Press [Selct].



Select Diagnostic Menu

Verify the VIEW SYSTEM SENSOR STATUS option is highlighted.

- Press [Selct] again to view the SENSOR STATUS SCREEN.

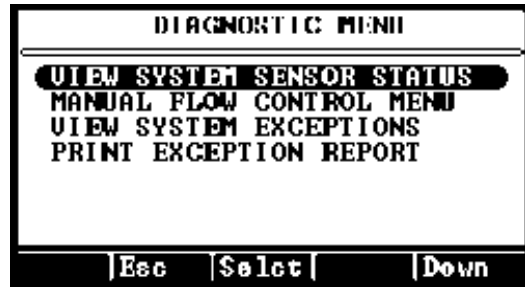

- If the flow rate is not at 100 ± 10 ml/min, see FLOW RATE on page 51
- Return to the MAIN TEST SCREEN by pressing [Esc] three (3) times.

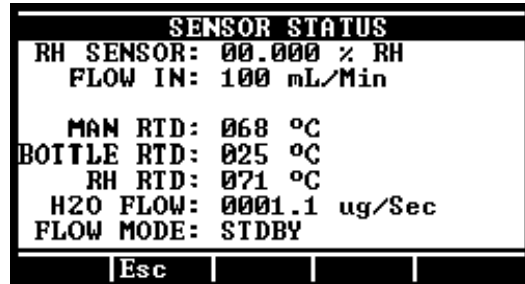

5.2.2. DRYNESS TEST

- When the display on the MAIN TEST SCREEN indicates READY TO TEST press and/or select in order:

- [Memry]
- *DRYNESS TEST*

- Press [START].

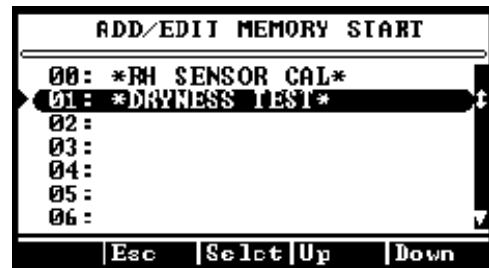

- This test will run for two (2) minutes to test for moisture that may have migrated into the system:

- If this is the first test after changing a portion of the flow system, desiccator, filter, etc., or if the result is more than $100 \mu\text{g}$ of H_2O , repeat the dryness test up to four (4) times.
- If the result does not fall under $5 \mu\text{g}$ after the 3rd or 4th test:
 - › Check for moisture in the desiccator and other portions of the dry air supply line.
 - › Call AZI Customer Service at 800-528-7411 or 602-470-1414 for assistance.



6. RH SENSOR CALIBRATION

The water calibration test verifies that the instrument is working properly. This test only takes a few minutes. Arizona Instrument recommends that:

- This test be run every day or before use to verify the system's calibration and accuracy,
- The syringe be returned for calibration annually or if damage is suspected, and
- The syringe is cleaned with acetone, before storing it away, after each day's use.

RH Sensor calibration is similar to the calibration test but enables revised parameters to be saved into memory to optimize accuracy.

6.1. SYRINGE TECHNIQUE

The information presented here will help you use the syringe, AZI P/N 990-0068, to perform the test described on the next page. The syringe uses the volume inside the needle as its calibrated quantity. It is important to eject any trapped air to properly fill that volume. Insert the syringe needle through the septum of the bottle, AZI P/N 990-0153, that has been filled with distilled or de-ionized water. Rapidly depress the plunger all the way and observe the needle tip for small bubbles. If any appear, repeat the cycle until none appear.

To reproducibly inject 0.5 μL of water with the supplied syringe, AZI P/N 990-0068:

- Ensure the needle tip is pushed through a septum in the lid of a sample bottle and immersed in water.
- Pull the plunger past the 0.5 μL graduation. The rod that goes through the lower Chaney fitting by the flange will be drawn through the hole in this fitting.
- Press in on the silver button on this lower Chaney fitting to close the hole.
- Depress the plunger until the rod touches the closed hole in the lower Chaney fitting.
- Hold the button in and the plunger against the stop until the syringe is fully seated in the instrument's Injection Port.
 - To prevent loss of water from the syringe by capillary action, do not touch the needle tip to anything until it is inserted into the Calibration Port of the instrument.

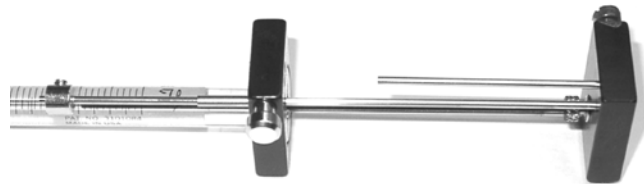

Drawn Position

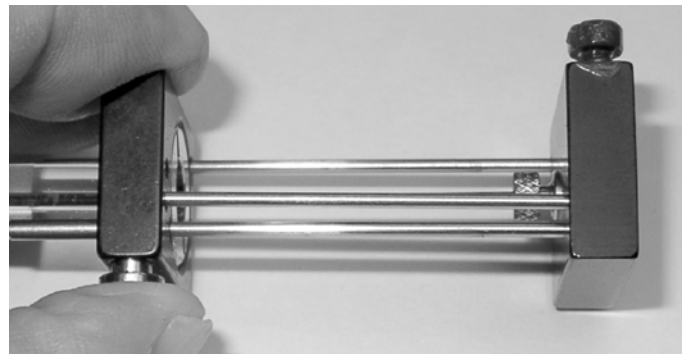

Silver Button Depressed and Rod Against Stop

- When prompted by the instrument, place the needle tip in the injection port at the top of the instrument, and insert it straight down until the septum is contacted.
- Continue pushing the syringe in until the needle touches the bottom of the injection port.



Needle resting on septum

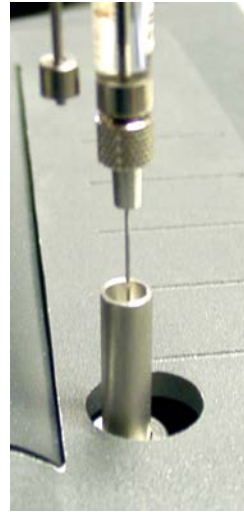

Needle fully inserted to bottom

- Release the silver button on the lower Chaney fitting and inject the 0.5 μL water by depressing the plunger fully with a firm, smooth stroke. This will dispense all water since the plunger wire displaces the entire capacity of the needle.
- Remove the needle from the injection port immediately.

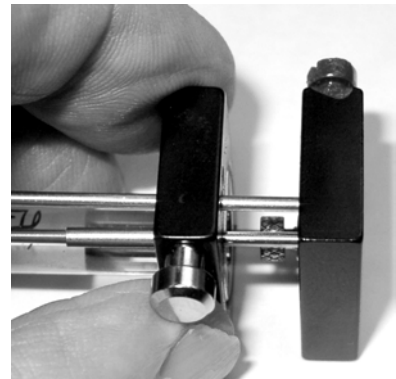

Syringe fully depressed

6.2. CALIBRATION CHECK

This procedure is a check of sensor accuracy using the statistical calculations in the Analyze Stored Data function. It will not affect the calibration constant value stored in the instrument. The Sensor Calibration procedure is found in section 6.3 and that procedure does have the capability of changing the stored calibration constant.

- Remove the one-microliter syringe from the box.
 - The syringe has been factory set with the actual calibration value listed on the calibration certificate.
 - Follow the previous instructions to load the syringe with distilled or de-ionized water from the septum capped sample bottle, AZI P/N 990-0153.
- When READY TO TEST is displayed on the MAIN TEST SCREEN, press and/or select in order:
 - [Memry]
 - *RH SENSOR CAL*
- Perform a calibration injection:
 - Prepare the syringe. Refer to section 6.1-SYRINGE TECHNIQUE as needed.
 - Press the [START] key. It is important to begin the test promptly since the water will evaporate out of the syringe needle. Almost immediately, the screen will display the blinking message **HAND INJECT WATER NOW**.
 - When prompted by the instrument, place the needle tip in the injection port at the top of the instrument, and insert it straight down until the septum is contacted. Push it in until it touches the bottom of the injection port.
 - Release the silver button on the lower Chaney fitting.
 - Inject the water by depressing the plunger fully with a firm, smooth stroke.
 - Remove the needle from the injection port immediately.
 - Allow the test to proceed until completed. It should take less than three (3) minutes.
- If this is the first test of the day, discard the results for unit stability reasons. Run as many tests as desired. One test is normally used for a confidence test while three (3) or more are used to determine if a calibration is required.

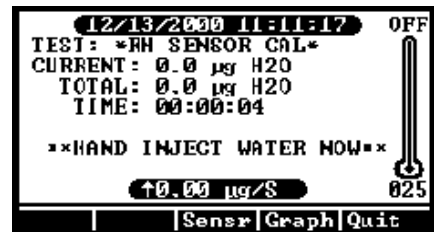

- If desired, perform four more calibration tests and calculate the statistics.

If this is a 21 CFR, Part 11 compliant instrument, all readings must be recorded by hand; AZI recommends using a printer to capture the values. The calculations must be performed on a calculator since the instrument's storage and analysis functions are disabled.

- Mean, Standard Deviation, and Coefficient of Variation are calculated using the following formulas.
 - Mean = total of results divided by number of results.
 - Standard Deviation = $\sqrt{\frac{\sum(\bar{x} - x)^2}{n - 1}}$
 - Coefficient of Variation = Standard Deviation divided by Mean times 100%
- After the fifth test, press [**Menu**] for MAIN MENU,
 - Press [**Select**] for STORED DATA MENU, (Not available in 21 CFR, Part 11 compliant instruments.)
 - Press [**Select**] for ANALYZE STORED DATA,
 - Highlight and [**Select**] the desired results to be included in the statistics, and
 - Press [**STAT**] to calculate Average, Standard Deviation, and Coefficient of Variation.
 - › The average should fall within $\pm 5\%$ of the syringe's calibrated value.
 - › If the mean result does not fall within the $\pm 5\%$ range, perform the sensor calibration in section 6.3 SENSOR CALIBRATION on page 19

6.3. SENSOR CALIBRATION

NOTES

A one micro liter, (1 μL), syringe which has been calibrated to 0.5 μL in volume, with the exact weight in micrograms (μg) clearly visible, or an NIST traceable syringe set to 0.5 μL or 500 μg , is normally used for this calibration. If another value is used, acceptable limits, given in percent in the following procedure, can be used to determine the success of the calibration. Since the operator, near the end of the calibration process, enters the value of the syringe, nearly any syringe, calibrated around the 1 μL range can be used.

The syringe has a very small barrel and piston that must be properly cared for to assure a correct injection is delivered to the instrument. After use, the syringe must be cleaned with acetone and stored in a desiccant box or it will freeze in place due to corrosion.

Clean the syringe by placing the needle in acetone, operating the plunger several times, and storing it with the plunger all the way in.

If the syringe becomes frozen, the needle may free up if soaked in water or acetone for 15-20 minutes. If it does not move freely after soaking, it should be replaced.

The syringe should be returned to AZI for calibration annually, or if damage is suspected. Contact AZI Customer Service to obtain a Return Material Authorization (RMA) number and prompt replacement.

AZI Part Numbers of commonly used items:

Injection Port Septa	990-0058
1μL Syringe (calibrated to 0.5 μL or as specified in the calibration certification) with Chaney Adaptor	990-0068

- At least five (5) tests are required for a calibration. Valid tests, those tests not affected by improper syringe technique, should be used to obtain optimum results.
- When READY TO TEST is displayed on the MAIN TEST SCREEN, press and/or select in order:
 - [Memry]
 - *RH SENSOR CAL*
- Perform calibration injections until at least five (5) valid tests are obtained:

NOTE: The following are abbreviated steps. Refer to CALIBRATION CHECK on page 17 for more complete instructions for the test.

- Prepare the syringe with distilled or deionized water.
 - › Insert the syringe into the septum of the sample bottle and fill the syringe.
 - › Rapidly depress the syringe's plunger to expel any air in the barrel.
 - › Fill the syringe and hold the plunger against the stop.
 - › Remove the syringe from the bottle.
 - Press **[START]**.
 - When the ****HAND INJECT WATER NOW**** prompt flashes on the display, **in one continuous motion**:
 - › Insert the syringe into the instrument's injection port to the stop,
 - › Rapidly press the plunger down, and
 - › Remove the syringe.
 - From the MAIN TEST SCREEN, press and/or select in order:
 - › **[Menu]**.
 - › CALIBRATION MENU
 - › PERFORM RH SENSOR CAL.
 - Highlight and **[Selct]** the desired tests to be included in the calibration.
 - Press **[Cal]**. The screen will display the calibration water mass. Press **[Edit]** to modify the calibration water mass if it does not match the value on the syringe or press **[Go]** if the mass is correct.
 - Press **[Quit]** and **[Accpt]** to exit edit mode and accept the new value, then press **[Go]** to move to the Calibration screen.
 - Review the results of the calculation.
 - › Coefficient of Variation should be less than 2%
 - If acceptable, press **[Accpt]** to save the new calibration constant.
- The new calibration constant will remain in memory until the next sensor calibration is performed. The injections used for this calibration will be automatically deleted so they will not be used for the next calibration.
 - Press the **[Esc]** key twice and the MAIN TEST SCREEN appears.
 - Perform at least one more water injection to verify the accuracy of the calibration.

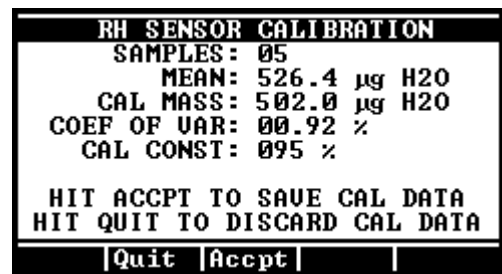

```
RH SENSOR CALIBRATION
SAMPLES: 05
MEAN: 526.4 µg H2O
CAL MASS: 502.0 µg H2O
COEF OF VAR: 00.92 %
CAL CONST: 095 %

HIT ACCPT TO SAVE CAL DATA
HIT QUIT TO DISCARD CAL DATA

|Quit |Accpt| |
```

7. TEMPERATURE CALIBRATION

NOTE: The temperature calibration and verification take approximately 5 hours.

Parts Required

Amt.	AZI Part Number	Description
1	Y990-0142	Temperature Calibration Kit with 9 VDC, 100 mA, 3.5 mm male plug, positive tip, DC Adaptor
1	Y990-0098	Graphics Printer with cable (optional)

- Install the Temperature Calibration Probe from the Temperature Calibration Kit into the port on the right side of the instrument as shown.

The probe must be inserted all the way in until the handle is flush with the case.

Run the cable around behind the instrument to help hold the probe in place.



- Connect the probe cable into the mating connector on the interface box.
- Connect the RS-232 cable between the interface box and the **Scale Input Port** on the back of the instrument.
- Connect the AC Power Adaptor into an appropriate AC outlet and plug the DC Plug into the power jack on the interface box.



- From the Main Test Screen, press or select in order:

- › [Menu]
- › CALIBRATION MENU
- › TEMPERATURE CALIBRATION
- › ENTER DEVICE DATA
- Enter the appropriate data for the interface serial number, probe serial number and calibration/certification date.

```

ENTER DEVICE DATA
-----
INTERFACE #: 00123
PROBE #: 04567
CERT DATE: 01/02/2002
-----
Esc Edit Down

```

- › The interface serial number and certification date are located on the temperature calibration interface label (the black box).
- › The probe number is located on the probe cable.

- Return to the TEMPERATURE CALIBRATION MENU; highlight VERIFICATION SETUP and press [Select].

- The purpose of the verification function is to confirm whether the calibration was successful or not at a given set of temperatures. The verification process can be run automatically following the calibration by selecting ON at the AUTO-VERIFY prompt.

```

VERIFICATION SETUP
-----
AUTO VERIFY: ON
TEMP #1: 080
TEMP #2: 120
TEMP #3: 160
TEMP #4: 200
-----
Esc Edit Up Down

```

- The rest of these instructions assume that the verification is being run automatically. (AUTO-VERIFY: ON)

- To select which temperature(s) will be verified, scroll down to the TEMP # prompt and press [Edit]. If you do not wish to edit the temperatures, press [Esc] and move to the next step.

- Using the arrow keys, enter the temperature you wish to verify and press [QUIT] and [Accpt]. The temperatures selected should be the ones that best represent those used for your product(s). When finished, press [Esc].

- Highlight RUN TEMP CAL and press [Select]. The next screen will ask to ensure that you have the temperature calibration device. If the device is hooked up, press [Go].
- When the verification is complete, the screen will display either the statement, “Verify: Passed” or “Verify: Failed.”
- Press [Go] at the bottom of the display to return to the CALIBRATION MENU.
- If a printer is available, highlight and select Print Temp Cal Report.
- If the unit failed at any given point, save the data and run the calibration again to improve the results.
- When the calibration is complete, turn the instrument off and disconnect the calibration interface.
- Press [Esc] until returned to the Main Test Screen.

8. RUNNING MOISTURE TESTS

The Computrac® VAPOR PRO® Fx has 102 available positions to store test parameters for different materials. Storing the parameters ensures that each test of the same material will use the same parameters to assure accurate, reliable, and repeatable testing.

8.1. SELECT TEST SETTINGS

- From the MAIN MENU, select MEMORY START MENU.
- From the MEMORY START MENU, select ADD/EDIT MEMORY START.
- Move the cursor down to an available memory start setting (a blank line).



8.1.1. ENTER MATERIAL NAME

- Select EDIT SAMPLE ID
- Enter the ID name:
 - The [**Incr**] and [**Decr**] keys scroll through the alphanumeric characters.
 - The [**Left**] and [**Right**] keys move the cursor's position left and right.

“TIP”

If a keyboard is included with your system use the arrow keys on the 101-key keyboard to navigate the menu system. The keyboard makes entry of long strings of characters such as product names easy, since all the alphabetic and numeric keys can be used while editing. The F1 key serves as [**Esc**].

- When complete, press [**Quit**] and [**Accpt**].

8.1.2. SET PROGRAMMED TEST TEMPERATURE

- Determine the Test Temperature.
 - Generally, the instrument is relatively insensitive to the exact temperature used. However, too low a temperature will result in possibly low results. Too high a temperature may cause sample to break down; turn to a gummy solid, tar, or sludge; release unwanted volatiles, and/or burn.
 - In most cases, it is best to determine the temperature at which a physical change occurs in the sample material. (These are the temperatures where cooking oil begins to stick and crude oil becomes sticky.) This may be done in a separate oven where the temperature may be increased until an undesirable change takes place. Set the **test** temperature 10 to 20 degrees below the observed temperature.
- Set the Test Temperature.
 - Select TEMPERATURES
 - Highlight TEST TEMPERATURE and press **[Edit]**.
 - › Use the **[Left]** and **[Right]** keys to move the cursor's position left and right.
 - › Use the **[Incr]** and **[Decr]** keys to increase or decrease the numbers to set the desired temperature.
 - › When complete, press **[Quit]** and **[Accpt]**.

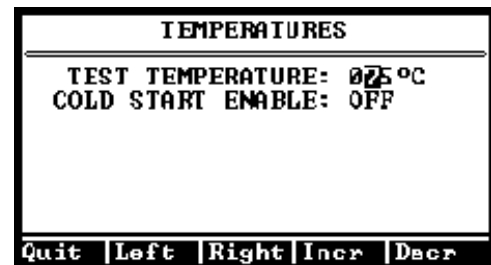

8.1.3. SELECT UNITS FOR THE FINAL RESULT DISPLAY

- Select RESULT DISPLAY OPTION.
- Press **[Edit]**.
- Use the **[Incr]** and **[Decr]** keys to select the type of moisture value for the test result to be displayed. Selections are:
 - Percentage (%) of water,
 - Parts per million (ppm) of water, and
 - Micrograms (μg) of water measured.
- When complete, press **[Quit]** and **[Accpt]**.

8.1.4. SELECT HOW TO END THE TEST

- Select ENDING CRITERIA.
- Press [Edit].
- Use the [Incr] and [Decr] keys to choose the type of ending value.
 - **Rate** ends the test when the moisture evolved from the sample drops below the programmed microgram per second value. Use RATE if you want to match an existing standard or method that utilizes a RATE criterion (such as the KF titration method). This method is extremely dependent on the amount of sample used and water collected during a test. For repeatability testing, use very consistent sample sizes that are all within 0.2 grams of each other.
 - **Time** ends the test when the programmed testing period has elapsed. The test will end when a selected amount of time has passed. Any value from 001 to 999 minutes may be entered. Fixed time ending is useful when conducting application characterization tests, or when investigating long-term stability of the instrument.
 - **Time then Rate** ends the test when the moisture evolved from the sample drops below the programmed microgram per second value, **after** the programmed time period has elapsed. This ending criterion is useful for samples that take a long time to heat up before evolving moisture, or, in other words, when the rate curve for a sample stays low for a period of time before rising significantly once the moisture starts evolving.

8.1.5. SELECT SAMPLE WEIGHT ENTRY MODE

- Select SAMPLE WEIGHT ENTRY MODE.
- Press [Edit].
 - **Manual Weight Entry** – allows manual entry of the sample weight. The program waits at the start of a test until the sample weight in grams is entered. An analytical balance is used to weigh the syringe before and again after it is filled. The empty syringe weight is subtracted from the full syringe weight and the result entered manually into the instrument as the sample weight.
 - **Digital Balance** – allows the serial connection between a digital balance and the instrument to input the measured weight of the sample. The empty syringe is tared, filled and placed back on the balance. The sample weight is communicated directly from the balance to the instrument.
 - **Fixed Sample Weight** – This method is used when all samples are of the exact same weight for accurate moisture analysis or close enough to an average value for approximate moisture analysis. The program will wait until a fixed weight value is entered.
 - **Volume** – This method is used when the sample volume is known, but the weight or density are not. The instrument assumes a density of 1, so this mode is not recommended if the density is believed to be significantly different than 1.
 - **Density** – This method is used when the density of the sample is known, but the actual sample weight is not known or cannot be determined.

8.1.6. SET SYRINGE FEED TIME

- Select SYRINGE FEED TIME
- Press [Edit].
 - **Syringe Feed Time** is the total time for the sample to be completely injected into the instrument's heated coil. When using a 5cc syringe, one (1) minute per cc is usually acceptable. When using the 1cc syringe, one minute per .2cc is usually acceptable. To reduce the overall test time, reduce the syringe feed time in increments until evolved moisture begins to reduce. A fast feed time will probably not produce an accurate result.

8.1.7. CORRELATION FACTOR

Each Memory Start also has a Correlation Factor parameter. This parameter defaults to 100% for all Memory Starts. **Use 100% for all samples unless it is found by experiment that another value is more appropriate.** Contact AZI Customer Service for help in determining the proper value for difficult applications.

8.1.8. DETERMINE SAMPLE SIZE

- If you are attempting to match KF analysis results, find out what sample size and 'sensitivity' setting was used in the KF procedure. Use approximately ten (10) times as much sample in the Computrac® **VAPOR PRO® Fx**, and set the rate ending criteria value to ten (10) times the 'sensitivity' value used in the KF equipment.

Example:	<u>KF Sensitivity Setting</u>	<u>KF Sample Size</u>
	0.1 µg/sec	0.5 grams
	<u>Computrac® End Rate</u>	<u>Computrac® Sample Size</u>
	1.0 µg/sec	5 grams

- If you do not have the KF parameters available, perform the following experiment.
 - Select a sample size that will yield 500 to 1000 micrograms of water but will not be smaller than 1cc nor greater than 5cc in volume.
 - › For best accuracy and speed, the sample should evolve between 500 and 1000 micrograms of water during the test. Larger amounts will not significantly improve accuracy, and will only add to the test time. Smaller quantities will result in faster tests but may degrade accuracy, depending on the properties of the sample. No damage to the instrument will ensue if samples are too small
 - To estimate sample size, you must have some idea of the approximate moisture content of the sample. Use the calculation shown below to estimate the minimum sample size.

$$\text{Minimum Sample (g)} = \frac{0.05}{\text{Expected Moisture (\%)}}$$

If: Expected Moisture = 0.05%
Then: Minimum Sample = 0.05/.05 = 1.0 grams

- Similarly, the maximum sample is determined by what size sample will release 1000 micrograms of water.

$$\text{Minimum Sample (g)} = \frac{0.1}{\text{Expected Moisture (\%)}}$$

If: Expected Moisture = 0.05%

Then: Maximum Sample = $0.1 / .05 = 2.0$ grams

- These are only guidelines and the sample volume should remain between 1cc and 5cc. Experiment with your sample to refine the size estimates to achieve your desired speed and accuracy. Note that if you are using a rate-ending criterion, and the peak moisture rate is less than five (5) times the rate threshold, the sample sizes should not be allowed to vary more than about 10%. Large variations in sample size will lead to large variations in results.

For some products, better results are obtained when fed into the **VAPOR PRO® Fx** from a 1cc (1ml) syringe. An adaptor is available from AZI to allow the syringe transport to handle the 1cc syringe. The adaptor will be installed at the factory when it is ordered with a new instrument. It may be removed and/or installed at any time. The adaptor is AZI P/N: 300-0559 and the one-time-use 1cc plastic syringe is AZI P/N: 990-0203.

The adaptor drops into the transport in place of the 5cc syringe and is held in place by a jam screw. The syringe, filled to a maximum of 0.8cc, is placed into the adaptor and tests are run following the usual procedure described in the next section.

Note orientation of the 1cc syringe.

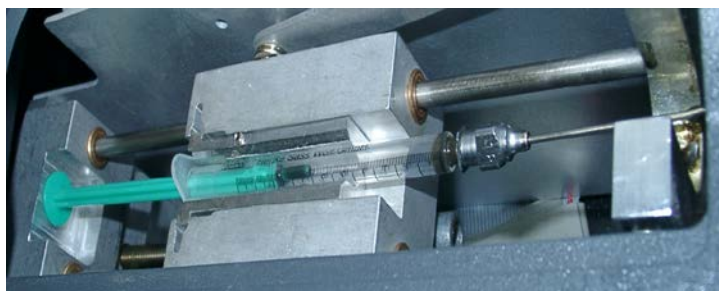
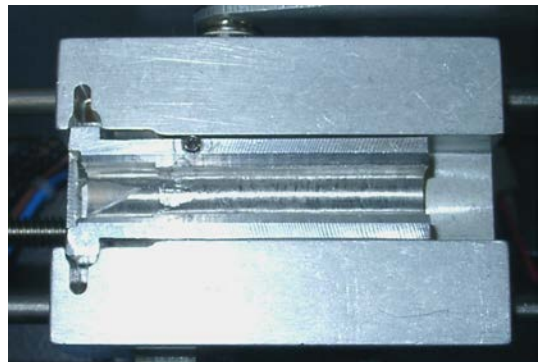

8.2. RUN MOISTURE TEST with 5cc Syringe

- Tare a clean, empty syringe.
- Based on the expected moisture content of the sample, determine optimum sample size using the equation on page 26 and fill the syringe to between 1cc and 5cc.



NOTE: Use the 1.5" needle with a glass syringe and the 2" needle with a plastic syringe.

- Weigh the loaded syringe and record the weight of the sample.
- Open the instrument's access door.
- Raise the loading lever to its full upright position. A stop will prevent over-travel.

Note that the **Syringe Holder** has a stepped slot on the left side. The glass syringe will fit into the left-most portion of the slot. The plastic syringe will fit into the right-most portion of the slot.

- Insert the syringe (glass syringe with 1.5" needle is shown for clarity) into the instrument's transport assembly as shown.
- Lower the loading lever all the way down to fully insert the syringe's needle into the heated coil.

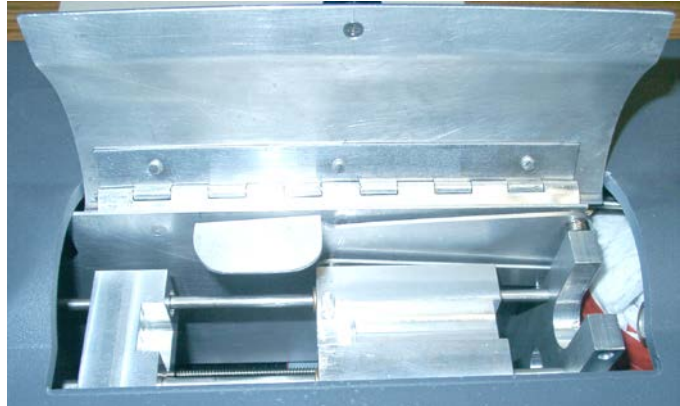

- Close the transport access cover.
- Press [START].



- When prompted, enter the sample size in cc.
- When prompted, enter the initial sample weight.
- The test will proceed until the ending criteria have been met.

ENTER SAMPLE SIZE
20.0 cc

ENTER INITIAL SAMPLE WEIGHT
20.0000 g

“TIP”

The AZI ZSP150 digital balance [AZI P/N Y990-0082] eliminates possible transcription errors when entering the sample weight. It is also faster than manually taring and weighing the sample. See APPENDIX A - AZI ZSP150/SP150 OR SCI SA800 DIGITAL BALANCE on page 52 for more information.

9. MENU SYSTEM

- In the idle state, the MAIN TEST SCREEN displays menu access keys at the bottom. From left to right they are:
 - **[Memry]** key - for accessing stored memory start selections,
 - **[Menu]** key - for accessing the Main Menu, and
 - **[Graph]** key - for changing the display to a graph of collected moisture and rate information.
- Use keys below the displayed prompts to make your selection.

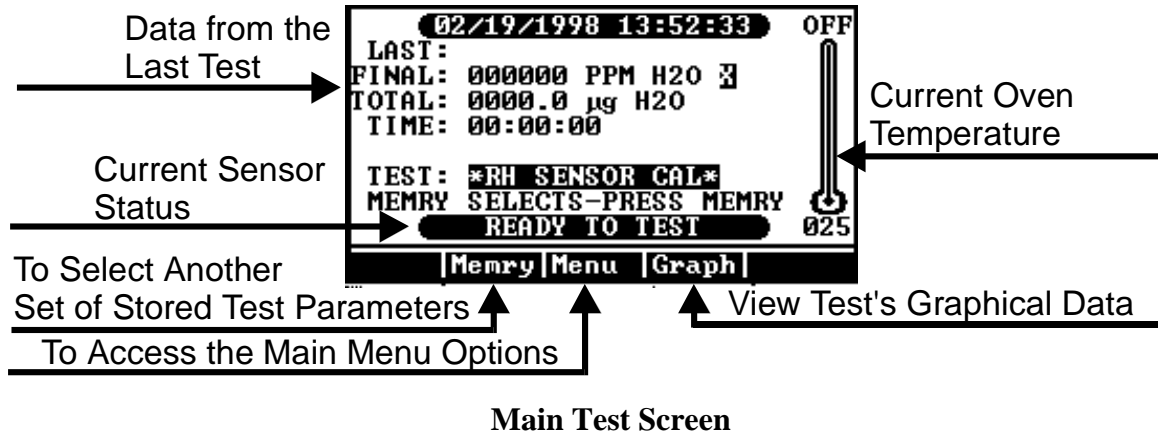

- The **[Graph]** key can be used to switch the display to the graphical displays.
 - Press **[Graph]** and the graph displays total moisture and the name above the arrow button changes to **[Next]**.
 - Press **[Next]** and the graph changes to display the rate at which moisture is passing over the sensor.
 - Pressing **[Next]** will now toggle between the two graphs.
- To return to the MAIN TEST SCREEN press **[Esc]**.

- Pressing [Menu] brings up the MAIN MENU screen showing the following options:
 - MEMORY START MENU
 - STORED DATA MENU
 - CALIBRATION MENU
 - SETUP MENU – two screens
 - DIAGNOSTIC MENU

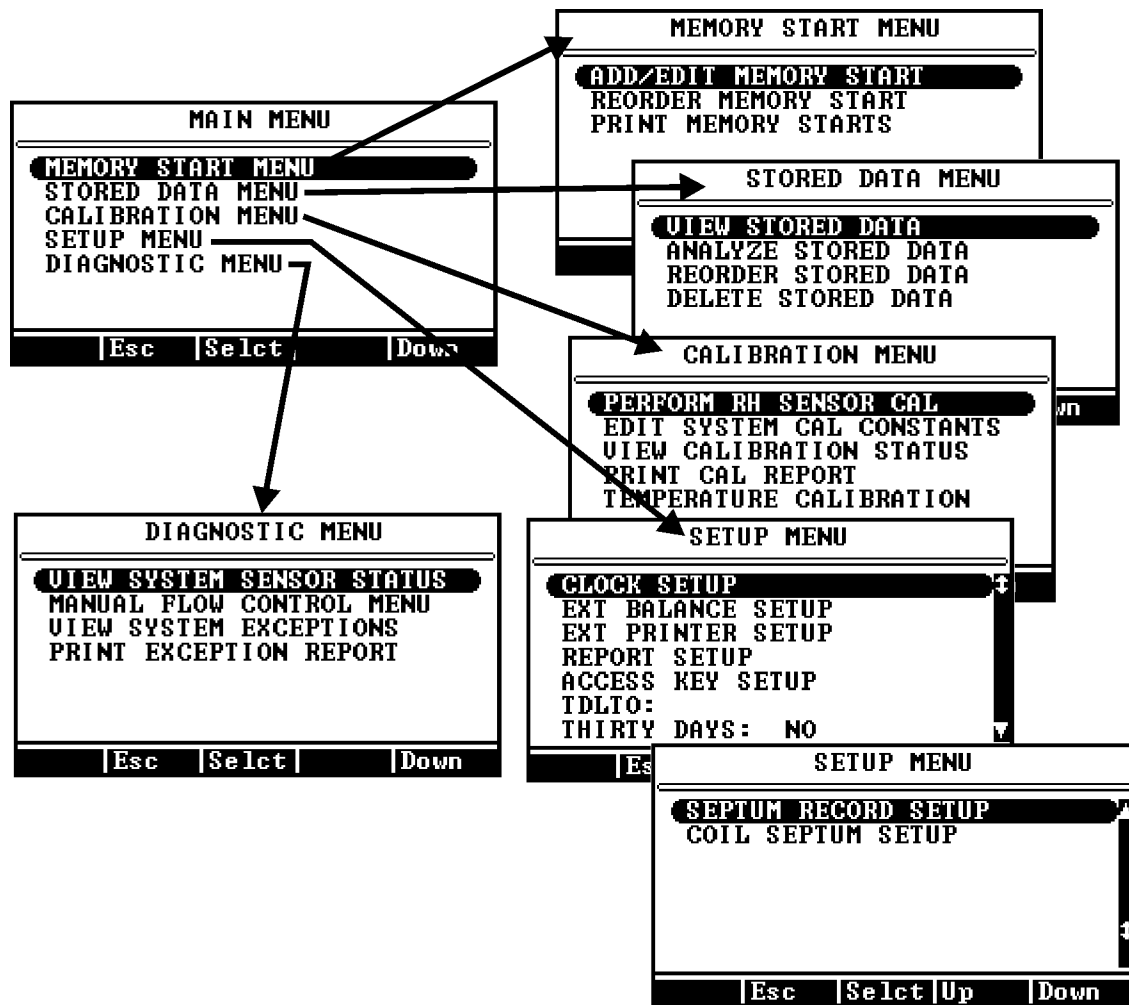

- Use the [Up] and [Down] keys to scroll through the selections and the [Esc] and [Select] keys to “Escape” or “Select” your choice.
 - As various selections are made the use of the arrow keys will change to present functions appropriate to the selection, such as Go, Toggle, Edit, Quit, and Accept.
 - For editing, the [Incr] and [Decr] keys will cycle through available letters, numbers and symbols so that names can be spelled and numeric values can be entered.

9.1. MEMORY START MENU

- ADD/EDIT MEMORY STARTS
 - Sets the values for stored test parameters. The parameters are stored by name. Values are stored for test temperature, ending criteria, result display units, method of sample weight entry, syringe feed time and correlation factor.
- REORDER MEMORY STARTS
 - Allows the list of stored parameter sets to be rearranged. It also deletes sets no longer needed, or copies existing sets to another location using the “cut and paste” method.
- PRINT MEMORY STARTS
 - Prints a list of the stored parameter sets on the attached printer, or to an attached computer. See the menu selections of Printer Setup and Report Setup, Report Content to arrange the instrument for this purpose.

9.2. STORED DATA MENU

This function is not available on 21 CFR, Part 11 compliant instruments

- VIEW STORED DATA
 - Allows viewing and printing of all data stored for a given test.
- ANALYZE STORED DATA
 - Permits selection of stored data sets for statistical analysis. Statistical analysis includes mean, standard deviation (S.D.) and coefficient of variation (C.V.).
- REORDER STORED DATA
 - Rearranges the order of the list of stored data sets. It also deletes sets no longer needed, or copies existing sets to another location using the “cut and paste” method.
- DELETE STORED DATA
 - Facilitates deletion of selected data sets. Selection by line, date or all items.

9.3. CALIBRATION MENU

- **PERFORM RH SENSOR CALIBRATION**
 - To be used carefully and only when required to calibrate the moisture sensor. This selection uses the stored data sets and the calibrated syringe volume to calculate and store the calibration constant in the instrument.
- **EDIT SYSTEM CAL CONSTANTS**
 - RH SENSOR V0 and RH SENSOR V75 are relative humidity sensor calibration factors. These values are found written on the sensor printed circuit board and are entered when a new sensor is installed in the sensor block.
 - SYSTEM CAL is a calibration factor for the relative humidity sensor operating in the instrument's flow system. It is automatically inserted into the instrument's memory when a sensor calibration is performed. It should not be edited from the value inserted during the water injection calibration.
- **VIEW CALIBRATION STATUS**
 - This selection allows review of the calibration status and activity of the RH sensor, automatic sensor zero adjustments, dryness test dates and background moistures, flow transducer adjustments, and the date of the last temperature calibration and/or verification.
- **PRINT CAL REPORT**
 - Prints all calibration status reports.
- **TEMPERATURE CALIBRATION**
 - The six selections in this menu provide the functions of data entry, calibration, verification, report printing, and calibration due reminder. A full explanation of most selections is given in section 7, TEMPERATURE CALIBRATION, beginning on page 21.
 - Cal Reminder Setup – provides a prompt to remind the user when the temperature calibration is due. It may be toggled ON or OFF and set for 000 to 999 days.

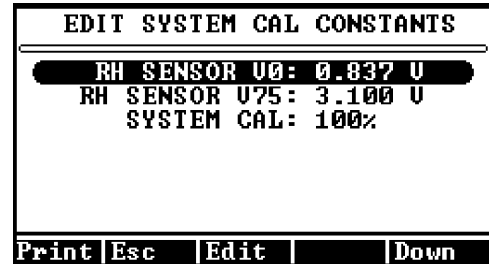

9.4. SETUP MENU

- CLOCK SETUP
 - Sets the internal clock for the correct time and date.
- EXT. BALANCE SETUP
 - Identifies the type of external balance (AZI ZSP150/SP150 or SCI SA80), see APPENDIX A - AZI ZSP150/SP150 OR SCI SA800 DIGITAL BALANCE on page 52.
 - Selects the tare mode (fixed or manual bottle weight entry or balance entry), and
 - Verifies the communication link between the instrument and balance.
- EXT PRINTER SETUP
 - Selects the type of printer used and specifies the output port where data is to be sent (RS-232, LPT, or both).
 - Select EPSON RASTER for the Epson[®] C88+ printer.
- REPORT SETUP
 - REPORT CONTROL specifies when the report is to be printed (off, at the start, at the end), selects the output format (text or spreadsheet), specifies the reporting interval in seconds, turns on or off end-of-line automatic form feeds, selects which graph to print (both, rate, result, none), and turns lot number recording on or off.
 - REPORT CONTENT specifies whether particular items of information are to be included in the report, or not. These items are:
 - MEM SELCT #
 - ID
 - LOT NUMBER
 - PRODUCT ID
 - TEST DATE
 - TIME OF DAY
 - FINAL RESULT
 - FINAL MASS
 - END CRITERIA
 - SAMPLE WT
 - TEST TIME
 - TEST TEMP
 - FINAL RATE
 - PEAK RATE
 - PEAK TIME
 - FLOW IN
 - SYRINGE TIME
 - BLOCK BKGND - Sensor block background
 - SAMPLE SIZE
 - EDIT COMPANY NAME allows you to change the company name that prints on the header line of the report.

- ACCESS KEY SETUP
 - Allows entry of the access codes used to prevent unauthorized alteration of stored parameter sets, or stored data sets. The MASTER KEY controls all functions. The PARAMS KEY controls memory start parameter list access.
- SEPTUM RECORD SETUP
 - This function resets the injection port septum counter. When the septum has been used 60 times, a message will warn the operator to replace it. When the replacement is accomplished, use this function to reset the count to zero.
- COIL SEPTUM SETUP
 - This function resets the test coil injection port septum counter. When the septum has been used 20 times, a message will warn the operator to replace it. When the replacement is accomplished, use this function to reset the count to zero.

9.5. DIAGNOSTIC MENU

- VIEW SYSTEM SENSOR STATUS – Displays current system status:
 - Moisture measured by the RH sensor,
 - Carrier dry air flow rate as measured by the flow sensor,
 - Sensor block temperature as measured by the sensor block RTD^{*1},
 - Coil temperature as measured by the heater coil RTD,
 - RH sensor temperature as measured by the RTD built into the RH sensor,
 - Current rate at which water vapor is flowing over the RH sensor, and
 - The dry airflow control mode.
 - During a test this display changes to indicate the TEST flow control mode is active.

SENSOR STATUS	
RH SENSOR:	0.300 % RH
FLOW IN:	102 mL/Min
BLOCK RTD:	068 °C
COIL RTD:	075 °C
RH RTD:	071 °C
H2O FLOW:	1.1 ug/Sec
FLOW MODE:	STDBY
Esc	

SENSOR STATUS	
RH SENSOR:	0.300 % RH
FLOW IN:	102 mL/Min
BLOCK RTD:	068 °C
COIL RTD:	075 °C
RH RTD:	071 °C
H2O FLOW:	1.1 ug/Sec
FLOW MODE:	TEST
Data	

- MANUAL FLOW CONTROL MENU
 - This menu allows manual control of the dry airflow to test and analyze possible system faults.
 - › OFF returns the system to automatic control of the flow state.
 - › COIL PURGE turns the high airflow rate on to clear the coil and sump of remaining fluids.



If any manually controlled flow state is used, ensure the manual flow control is set to **OFF before attempting normal operation. If this is overlooked, an error message will be appear on the screen.**

- VIEW SYSTEM EXCEPTIONS
 - A list of the last 20 faults detected by the instrument diagnostic system. Print the list and fax it to AZI Customer Service at 800-528-7411 or 602-470-1414 to assist in diagnosis of possible system failure.
- PRINT EXCEPTION REPORT
 - Prints the stored list of instrument diagnostic exceptions.

^{*1} - An RTD is a Resistive Temperature Detector that is used to measure temperature.

10. CONDITION PROMPTS AND SYSTEM FAILURE CODES

To assure proper performance, your Computrac® VAPOR PRO® Fx uses an intelligent self-diagnostic system to detect any problems in the hardware, software, sensors, or flow system. Operating abnormalities and fault conditions will result in **condition prompts** or **system failure codes**. They will be recorded in the Exception Reports table.

10.1. CONDITION PROMPTS

Condition prompts indicate operating conditions that prevent starting or completing of a moisture test. Following each condition prompt are possible causes and recommended solutions.

“INPUT CARRIER DRY AIR FLOW LESS THAN 40 mL/Min”

This prompt results when the source flow into the instrument falls below the specified rate.

Possible Cause	Recommended Solution
Source of carrier dry air not connected	Connect source
Source pressure too low	Ensure source pressure is 12-20 psi
Source connected to ‘flow out’ barb	Connect to ‘flow in’ barb
Flow sensor failure	Call Arizona Instrument

“THE RH SENSOR WAS NOT READY”

This is a normal condition between tests, indicating the drying or ‘zeroing’ of the sensor. If the condition persists for more than a few minutes then:

Possible Cause	Recommended Solution
Flow system contaminated	Locate and eliminate contamination
System unusually wet	Wait for system to dry
Wet source dry air	Install/change external desiccant chamber

“SEPTUM CHECK WARNING”

The septum at the calibration injection port has experienced 60 water injections and may be in danger of losing its core into the flow system. Change the septum and reset the counter by selecting SETUP MENU (from the MAIN MENU), then SEPTUM RECORD SETUP, and then press [GO].

“COIL SEPTUM WARNING”

The septum at the test coil injection port has experienced 20 injections and may be in danger of developing a leak. Change the septum and reset the counter by selecting SETUP MENU, (from the MAIN MENU), then COIL SEPTUM SETUP, and then press GO.

“SUMP OR COIL IS CLOGGED,”

Clean out the sump or coil before running tests. Turn power off and back on after clog is cleared.

“BALANCE COMM FAILURE”

This prompt indicates that the memory start used specifies the use of a digital balance for weight entry, but that the instrument is not communicating with a balance. Check the cable, and assure that the balance is powered on, online, and stable.

10.2. SYSTEM FAILURE CODES

Occurring less frequently than condition prompts, system failure codes require the instrument to be switched off and then powered back up. It is possible for a failure to occur due to a transient condition. However, if the failure persists or occurs frequently, call Arizona Instrument Customer Service at 800-528-7411 or 602-470-1414 for assistance.

ERROR CODE	ERROR MESSAGE TEXT	MOST LIKELY CAUSE
2	PC KEYBOARD COM FAIL	BAD CABLE OR CONFIGURATION
3	PC KEY CONTROLLER TIMEOUT	DEAD KEYBOARD
4	FLOW CALIBRATION WARNING	FAILED FLOW SENSOR
5	RH SENSOR RANGE ERROR	FAILED RH SENSOR
6,7	FLOW SYSTEM ERROR	CABLE OR SENSOR FAILURE
8	RH RTD RANGE ERROR	CABLE OR RTD FAILURE
9	RH RTD RATE ERROR	SENSOR BLOCK HEATER
10	RH RTD TRACK ERROR	SENSOR BLOCK RTD OUT OF POSITION
11	COIL RTD RANGE ERROR	CABLE OR RTD FAIL
12	COIL RTD RATE ERROR	COIL HEATER FAILURE
13	COIL HEATER OVERTEMP	COIL HTR RTD OUT OF POSITION
14	COIL HTR CONTROL ERR	ROOM TOO COLD
15	BLOCK RTD RANGE ERROR	CABLE OR RTD FAILURE
16	BLOCK RTD RATE ERROR	SENSOR BLOCK HEATER FAILURE
17	BLOCK HEATER OVERTEMP	SENSOR BLOCK RTD OUT OF POSITION
18	BLOCK HTR CONTROL ERR	SENSOR BLOCK HTR OUT OF POSITION
19	A2D INIT FAILED	COMPONENT FAILURE, MAIN BOARD
20	A2D TIMEOUT ERROR	COMPONENT FAILURE, MAIN BOARD
21	MCU CLOCK FAIL ERROR	COMPONENT FAILURE, MAIN BOARD
22	COP TIMEOUT ERROR	COMPONENT FAILURE, MAIN BOARD
23	ILLEGAL OP CODE TRAP	COMPONENT FAILURE, MAIN BOARD
24	EPROM CHECK SUM FAIL	COMPONENT FAILURE, MAIN BOARD
25	SRAM CHECK FAIL	COMPONENT FAILURE, MAIN BOARD

11. COMMONLY ASKED QUESTIONS

Below are some commonly asked questions with answers and possible solutions.

Q: “What if my water injection results are zero (or near zero)?”

A: Make sure the syringe is being inserted all the way into the injection port.



Incorrect Placement

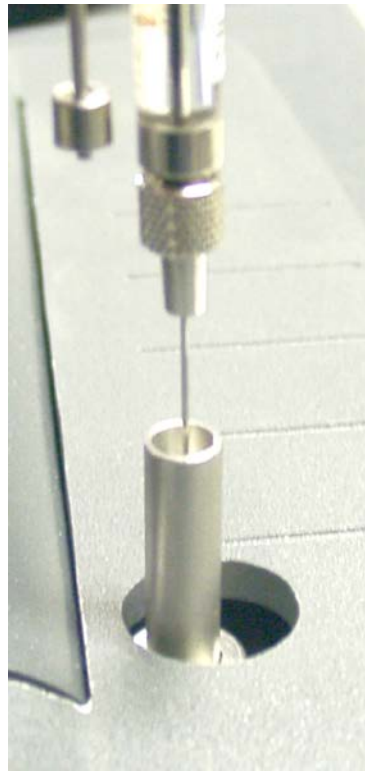

Correct Placement

Q: “What if my water injection results are out of range?”

A: #1 Perform a sensor calibration. The Computrac[®] VAPOR PRO[®] Fx self-adjusts the internal calibration factors to the high precision moisture sensor to account for varying conditions (temperature, product accumulation in the flow system, component wear, etc.). Over time, this may cause the overall calibration to drift slightly. Since sensor calibration is easily performed, daily verification is recommended.

A: #2 Check for leaks at Waste Jar. If performing a sensor calibration, as described above, does not bring the water injection results into range, there may be a gas leak at the waste jar. There are two ways to troubleshoot this situation, depending on whether or not a flow meter is available.

With a flow meter:

1. From the MAIN TEST SCREEN, select Menu → Diagnostic Menu → View System Sensor Status.
2. Connect the flow meter to the gas outlet port on the back of the instrument.
3. If the reading on the flow meter is less than the FLOW IN reading on the instrument screen and the difference is greater than 10 mL/ min, then there is a leak.
4. Adjust the position of the waste jar slightly while observing the reading on the flow meter until the reading on the flow meter matches the FLOW IN reading on the instrument screen.
5. If the two readings cannot be made to match by adjusting the position of the waste jar, try replacing the waste jar with a new one.

Without a flow meter:

1. From the MAIN TEST SCREEN, select Menu → Diagnostic Menu → View System Sensor Status.
2. Verify that the displayed FLOW IN is 100 ± 10 mL/min. If it is not, adjust the flow according to the procedure in §12.8 FLOW RATE and retry the sensor calibration before proceeding.
3. Fill a clean 200mL beaker with approximately 100mL fresh water.
4. Connect an 8 - 12” piece of tubing [AZI #345-0050] to the gas outlet port of the instrument, and place the other end of the tubing below the surface of the water in the beaker.
5. If there is no leak, a rapid flow of bubbles (approximately 8 to 10 bubbles/second) will exit from the tube in the beaker. If the bubbles are forming more slowly or not at all, then there is a leak in the system.
6. Adjust the position of the waste jar slightly while observing the beaker until the flow of bubbles proceeds at a fairly brisk pace.
7. If the flow of bubbles never increases, try replacing the waste jar with a new one.

Q: “How do I prevent the calibration syringe from freezing up?”

A: Clean the syringe in acetone before storing it at the end of each day’s use. The water collected in the small barrel of the syringe may not be seen but it is enough to cause the piston to jam against the barrel when it dries out or causes corrosion. The use of deionized water does not prevent corrosion and does not ensure other contaminants do not enter the syringe. Before storing the syringe for over 12 hours, clean the syringe by the following method:

- Insert the needle into acetone,
- Work the plunger up and down at least three times,
- Depress the plunger all the way into the syringe, and
- While holding the plunger all the way in, remove the syringe needle from the acetone and store the syringe in a box with desiccant.
- Before use in the instrument, purge the syringe completely to ensure that no acetone is injected into the instrument as it will affect or destroy the RH sensor.



Q: “How do I dry the instrument after an upset?”

A: When the instrument has been flooded with moisture, either by running a very wet sample, or by exposure to a wet gas supply, it will be necessary to dry the entire flow system before normal operation can be resumed.

- Inspect the tubing, sensor block, and needle to be sure that no contaminants are present that might absorb and release large quantities of water. If contamination is present, replace the contaminated parts with new parts.
- Confirm that the carrier dry air supply is dry. AZI recommends that the desiccator cylinder supplied with the accessory kit be used in-line with the dry air supply.
- Begin drydown of the system. Go to the Memory Start list and select *Dryness Test*. Start the test and periodically examine the rate graph display to see if the moisture rate is falling. If the moisture rate remains at a very high level a source of water is present in the system, and must be removed before dry-down will succeed. Normally, the rate will begin to decline after one (1) to three (3) minutes and eventually will fall to less than 1 µg/sec. When the moisture is below the 1 µg/sec., normal testing can resume.

Q: “What about RH sensor interferences?”

A: The only known interferences are from ammonium hydroxide, ethanol, methanol and acetone. Samples containing these and similar chemicals should never be used. Additionally, never use these substances as cleaning agents on or in the Computrac[®] VAPOR PRO[®] Fx instrument. Use isopropyl alcohol for cleaning instead.

Q: “What is good syringe technique?”

A: Good syringe technique is essential to accurate calibration. The syringe uses the volume inside the needle as its calibrated quantity. It is important to eject any trapped air to properly fill that volume.

Insert the syringe needle through the septum of a sample bottle of clean water (distilled or de-ionized water). Depress the plunger all the way down. Slowly withdraw the plunger to the stop. Rapidly depress the plunger all the way and observe the needle tip for small bubbles. If any appear, repeat the cycle until none appear. Slowly withdraw the plunger to the stop and hold it against the stop while withdrawing the needle from the septum.

To prevent loss of water from the syringe by capillary action, do not touch the needle tip to anything until it is inserted into the calibration port of the instrument. Start a *RH SENSOR CAL* (see page 19). When prompted by the instrument, place the needle tip in the injection port at the top of the instrument, and insert it straight down until the septum is contacted. Push it in until it touches the bottom of the injection port. Be careful not to move the plunger while inserting the needle. Depress the plunger all the way with a firm, smooth stroke. Remove the needle from the injection port immediately.

Store the needle in a dry place. A desiccator box is a good choice. If water is allowed to remain in the needle, it will cement the needle bore and plunger wire together. If this happens, do not force the plunger to move, as this will break the wire. Instead, insert the needle into the water bottle and let it soak for 15 minutes, or until it moves freely.

If the syringe is damaged, or is in need of annual calibration, contact AZI Customer Service at 800-528-7411 or 602-470-1414 for a replacement. After receiving an RMA number, return the damaged syringe to AZI for repair service.

Q: “Why do my tests sometimes end in less than 2 minutes?”

A: This is usually caused by an inappropriately large rate ending criterion value or the syringe feed rate is set too slow. A rate ending criterion and a syringe feed rate were entered during setup up for the sample test. If the sample moisture is very low, the sample is too small, or the feed rate too low, the peak rate will never exceed the ending rate and the instrument concludes that the test is over. To rectify this, use a larger sample, a lower ending rate value, or a slower syringe feed rate. See section 8.1.4-SELECT HOW TO END THE TEST, on page 25 or Section 8.1.6-SET SYRINGE FEED TIME on page 26

Q: “How do I transfer stored data to a computer file?”

A: To store archival information in a computer text file before deleting it from the instrument memory, set up the instrument to print to the RS-232 port. (SETUP MENU, EXTERNAL PRINTER SETUP). Go to SETUP MENU, REPORT SETUP, REPORT CONTROL and select TEXT OUTPUT. Go to the screen showing Print and select the report to be printed. Set up the computer to receive text information into its serial port at 9600 baud, no parity, 8 data bits and 1 stop bit (9600,N,8,1). Windows® Terminal or Windows® HyperTerminal are good choices for this purpose. Consult the documentation for your communications program for details on how to save input data to a file.

Q: “How do I print to a printer?”

A: To print test results or stored data:

- Connect the printer to the parallel port on the back of the instrument. Use the accessory printer kit from AZI, or most any PC compatible parallel printer and cable.
- Make sure the printer is supplied with paper, the printer power is on, and the printer is online.
- Go to SETUP MENU, and EXTERNAL PRINTER SETUP. Select the PRINTER TYPE and LPT port. NOTE: Use EPSON RASTER for the Epson® C88+ printer.
- Go to SETUP MENU, REPORT SETUP, and REPORT CONTROL. Select text output.
- Go to the screen showing [Print] and select the report to be printed.

12. REPAIR AND MAINTENANCE

Routine maintenance consists of checking for clogs and cleaning or replacing the flow path and or sensor. For clean samples, those that do not produce volatiles other than water, this is seldom necessary. For some samples, it may be necessary more often.

After inspection, cleaning or replacing parts, replace the access cover before connecting the instrument to its power source. Turn the instrument on and when READY TO TEST appears, run a dryness test. When the criteria for a dry system are achieved, the system is ready for use.

12.1. ACCESS COVER REMOVAL

- Refer to this procedure to gain access to the internal parts as directed in other sections of this manual.
- Turn the instrument off and remove the power cord from its socket.

⚠ CAUTION: ⚠

Line voltage is present under the instrument’s cover. To prevent electrical shock, turn off power, and remove the power cord. Do not re-connect the power cord and turn power on until after the cover is secured in place.

- Insert a small probe into the hole at the back of the instrument marked by a graphic symbol indicating the method of opening the access cover. Push inward to release the safety catch, and lift the cover up with your free hand. Remove it and put it in a safe place.



12.2. INSTRUMENT COVER REMOVAL

- Remove the access cover. See ACCESS COVER REMOVAL on page 43.
- **The sensor block is hot (68 °C); do not touch it with bare hands until it has been allowed to cool down.**
- Remove the instrument cover by unlatching the two latches on the back chassis wall. A long screwdriver is helpful.

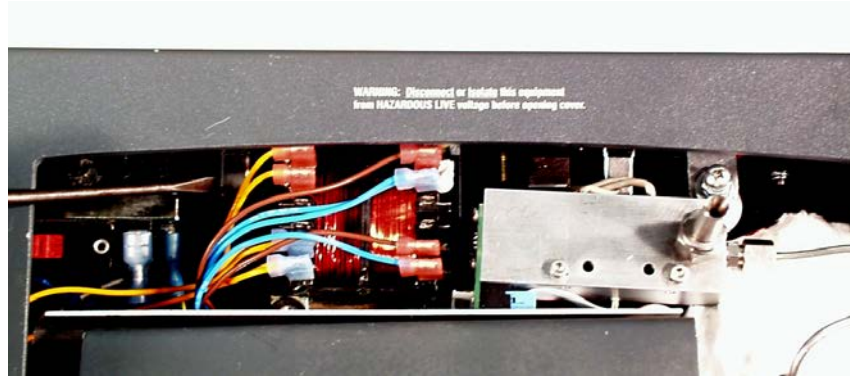

12.3. REMOVAL OF AIR TUBE, SENSOR BLOCK TO COIL

- The sensor block is visible in the center of the opening.
- **The sensor block is hot (68 °C). Do not touch metal parts with bare hands until they are allowed to cool down.**
- Disconnect the air tube from the right side of the sensor block.
 - Use a 5/16" wrench on the small half of the compression fitting and a 3/8" wrench on the large fitting.
- Disconnect the air tube from the top of the coil.

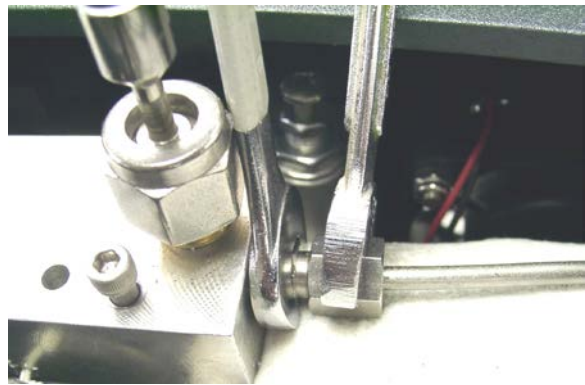
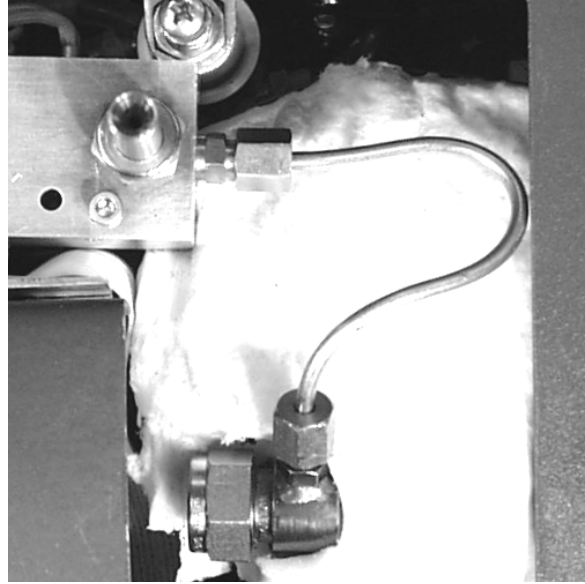

12.4. REPLACING THE CALIBRATION PORT SEPTUM

- Obtain a replacement septum, AZI P/N 990-0058. If the septa supplied in the accessory kit have all been used, call AZI Customer Service at 800-528-7411 or 602-470-1414 for parts.
- Remove the access cover. See ACCESS COVER REMOVAL on page 43.
- The injection port needle guide will be found near the right side and on top of the sensor block assembly. Use an 11/16" wrench to loosen the nut. Turn the nut counterclockwise to remove it. Lift off the needle guide and the nut.
- The septum is now visible at the top of the injection port or inside the nut.
- Replace the old septum with a new one.
- Replace the needle guide and nut; hand tight. Using the 11/16" wrench to turn the nut an additional 1/4 turn to load the septum.
- Replace the access cover and power cord. Turn the instrument on.
- Go to MAIN MENU, SETUP MENU, SEPTUM RECORD SETUP and press [GO] two (2) times.
- Press [ESC] three times to return to the MAIN TEST SCREEN
- The instrument is ready for normal use.

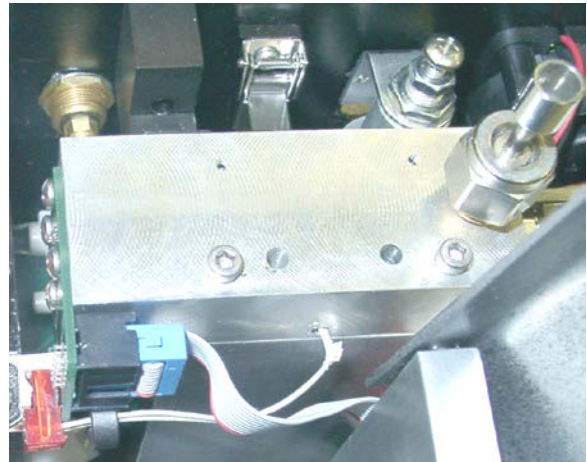
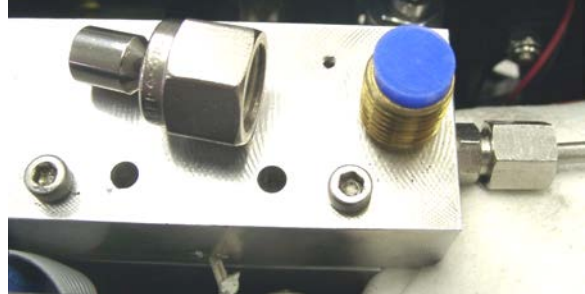

12.5. REPLACING THE SAMPLE PORT SEPTUM

- Obtain a replacement septum. AZI P/N 990-0132. If the septa supplied in the accessory kit have been used, call AZI Customer Service at 800-528-7411 or 602-470-1414 for parts.
- Remove the access cover. See ACCESS COVER REMOVAL on page 43.
- The sample port tube nut will be found at the top of the heater coil assembly. Turn the nut counterclockwise to remove it. If necessary, use an 11/16" wrench to loosen the nut.
- Remove the septum from the tube nut.
- Insert the new septum into the tube nut with the shiny, smooth coated side facing the threaded side of the tube nut as shown. This will place the shiny, smooth side of the septum towards the sample coil when reinstalled.

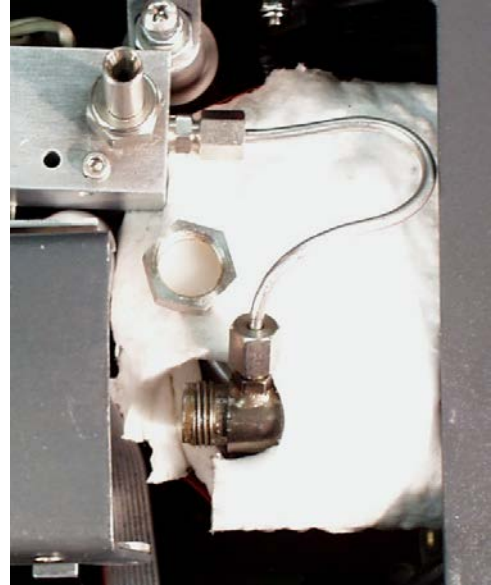

- Replace the tube nut; hand tighten it. **Do not tighten the nut with a wrench.**



- Open the syringe transport door and inspect the septum. Ensure that the septum did not buckle.
- Replace the access cover and power cord. Turn the instrument on
- Ensure that there are no flow system leaks. See LEAK CHECK THE SYSTEM on page 50
- Go to MAIN MENU, SETUP MENU, COIL SEPTUM SETUP and press [GO] two (2) times.
- Press [ESC] three (3) times to return to the MAIN TEST SCREEN.
- The instrument is ready for normal use.



12.6. HEATER COIL ASSEMBLY CLEANING

Use this procedure to clean the heated coil. If assistance is needed, call AZI Customer Service at 800-528-7411 or 602-470-1414.



WARNING!
Ensure the temperature of the coil is below the boiling point of the cleaning fluid or serious injury might occur when the cleaning solvent vaporizes and expels the syringe piston.



- Obtain several ounces of **isopropyl alcohol (IPA)**.
- Switch the MANUAL FLOW CONTROL to COIL PURGE.
 - Select in order from the MAIN TEST SCREEN:
 - › MENU
 - › DIAGNOSTIC MENU
 - › MANUAL FLOW CONTROL MENU
 - › COIL PURGE
- Press [**Esc**], highlight VIEW SYSTEM SENSOR STATUS MENU and press [**Select**].
- Place an airtight cap over the .020 orifice outlet barb. A wire tie may be necessary to keep the cap tight.
- Use a 5 cc plastic syringe equipped with a #22 X 2.0” needle AZI P/N 300-0466, to slowly (over 10 or more seconds) introduce the IPA into the calibration port.



- Slowly introduce 2 each 5-cc syringe loads of IPA through the test port septum.
- Allow time for the liquid to drain from the sump drain port.
- Remove cap from outlet barb.



- Remove the drain tube and place a sealing cap over sump drain port.
- Remove and set aside the .020 orifice outlet barb. IPA will be discharged through the outlet port. A rag, paper towel or other means can be used to eliminate splatter.



- Slowly introduce 2 cc of IPA into the calibration port.



- Remove the sealing cap from the Sump Drain Port and reconnect the drain tube to the hose barb.
- Replace the .020 orifice barb into the air outlet port.
- Keep the MANUAL FLOW CONTROL on Purge for 15 to 30 minutes to dry the system.
- Return the MANUAL FLOW CONTROL to OFF
- Wait for “READY TO TEST” to appear before using the instrument.
- If “READY TO TEST” does not come on in a reasonable time, return the system to manual purge for an additional 15 to 30 minutes and try again.



12.7. LEAK CHECK THE SYSTEM

- Obtain a port plug [AZI P/N PS-368]. If none are found, call AZI Customer Service at 800-528-7411 or 602-470-1414 for assistance.
- Connect the dry air/gas source to the dry air inlet.
- Install and tighten the port plug on the air outlet.

NOTE: If the outlet is cool enough, any plug or tight cover will do.

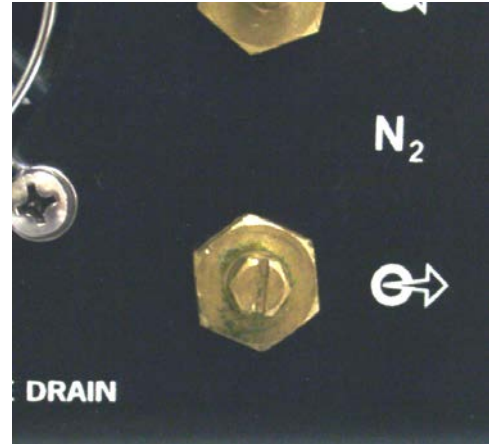

- From the MAIN TEST SCREEN, select the following menus:
 - › MENU,
 - › DIAGNOSTIC MENU, and
 - › VIEW SYSTEM SENSOR STATUS
- If FLOW IN is greater than 2 ml/min, track down the air leak and correct it.

SENSOR STATUS	
RH SENSOR:	0.000 % RH
FLOW IN:	001 mL/Min
BLOCK RTD:	068 °C
COIL RTD:	025 °C
RH RTD:	071 °C
H2O FLOW:	1.1 ug/Sec
FLOW MODE:	STDBY
Esc	

Possible cause might be the seal between the waste jar and the lid. Use AZI P/N PS-557. Apply thin coating to seal on lid of jar and retighten. NOTE: Do not over-tighten as it may cause damage to the seal area.

- [Esc] to the MAIN TEST SCREEN.
- Remove the port plugs.
- Reconnect the sump outlet tube.

12.8. FLOW RATE

- Verify the pressure of the carrier-gas supplied to the instrument is between 20 and 25 psi.
- Remove the access cover. See INSTRUMENT COVER REMOVAL on page 44.
- Replace the power cord. Turn the instrument on.



Line voltage is present under the instrument's cover. Use care not to touch any components except those listed in the following procedure to prevent electrical shock.

- From the MAIN TEST SCREEN, select the following menus:
 - MENU,
 - DIAGNOSTIC MENU, and
 - VIEW SYSTEM SENSOR STATUS

SENSOR STATUS	
RH SENSOR:	0.300 % RH
FLOW IN:	102 mL/Min
BLOCK RTD:	068 °C
COIL RTD:	075 °C
RH RTD:	071 °C
H2O FLOW:	1.1 ug/Sec
FLOW MODE:	STDBY
Esc	

- If FLOW IN is not 100 ± 2 mL/min, adjust the pressure regulator. There are two configurations of the flow regulator.
- On older instruments:
 - Locate the flow regulator that is mounted to the right of the display.
 - Loosen the lock nut on the adjustment screw and slowly adjust the hex-head screw on top of the inlet flow regulator CLOCKWISE or COUNTER-CLOCKWISE until the FLOW IN indicates 100 mL/min.
 - Tighten the lock nut.
- [Esc] to the MAIN TEST SCREEN.
- Turn the instrument off and remove the power cord from its socket.
- Replace the access cover and power cord. Turn the instrument on.
- The instrument is ready for normal use.

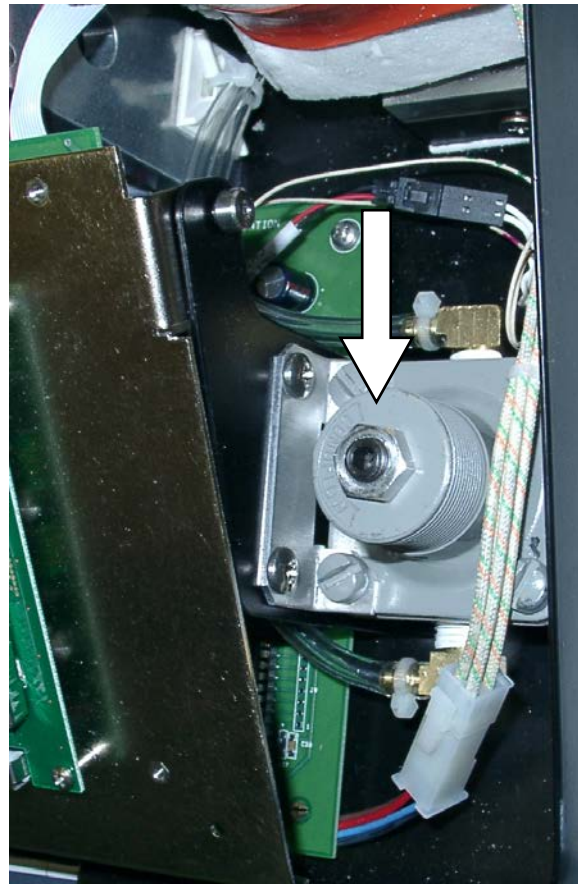

- On newer instruments:
 - Locate the flow regulator that is mounted to the right of the display.
 - Loosen the knurled lock ring on the regulator, then insert a regular screwdriver in the slot on the top of the regulator.
 - Turn the screwdriver slowly **CLOCKWISE** or **COUNTERCLOCKWISE** to adjust the inlet flow regulator until the **FLOW IN** indicates 100 mL/min.
 - Re-tighten the knurled lock ring.
- **[Esc]** to the MAIN TEST SCREEN.
- Turn the instrument off.
- Remove the power cord from its socket.
- Replace the access cover and power cord.
- Turn the instrument on.
- The instrument is ready for normal use.

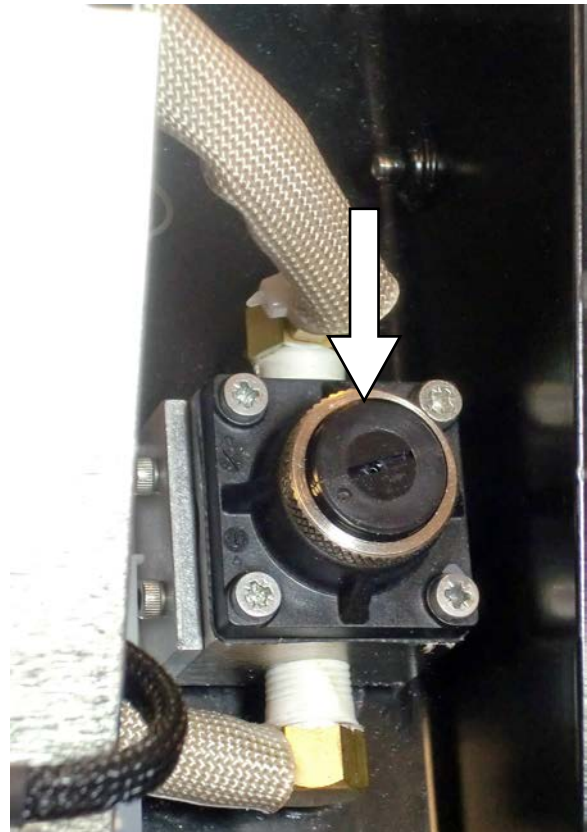

13. APPENDIX A - AZI ZSP150/SP150 OR SCI SA800 DIGITAL BALANCE

- From the MAIN TEST SCREEN, select the following menus:
 - MAIN
 - SETUP
 - EXT BALANCE SETUP
 - SELECT BALANCE DRIVER



Setup External Balance

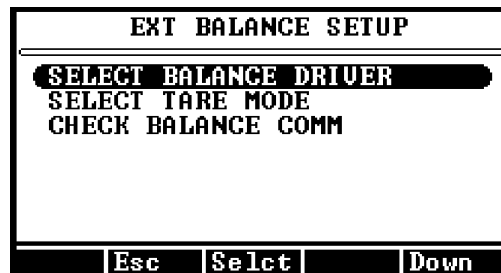

Select Functions

- Select the AZI SP150 or SCI SA800 according to the balance you have. Use AZI SP150 as the selection for both the ZSP150 and the SP150.
 - › Press **[Quit]**

- Press **[Accept]**
- Select the **SELECT TARE MODE** menu. The tare mode is only used when the **SAMPLE WEIGHT ENTRY MODE** is set to **DIGITAL BALANCE** in the memory start.
 - **FIXED SYRINGE WEIGHT** - The syringe weight is exactly the same. The balance is tared without the syringe and the fixed weight must be subtracted from the final measured weight.
 - **MANUAL SYRINGE WEIGHT** - The syringe is pre-weighed by hand. The balance is tared without the syringe and the weight of the syringe must be subtracted from the final measured weight.
 - **TARE EMPTY SYRINGE** - The balance tare weighs the syringe before it is filled with sample and the final measured weight is the weight of the sample.
 - **[Esc]** to the **EXT BALANCE SETUP** menu.
- Connect the cable between the Computrac[®] **VAPOR PRO[®] Fx** balance input connector and the RS-232 connector on the balance.
- Turn the balance power on and wait for the ready indication.
- Select the **CHECK BALANCE COMM** menu.
 - Press **[Go]** and wait for communication to be established.
 - If the check is bad, verify each step above.
 - If the check indicates good communication, a weight will be shown on the display.
 - **[Esc]** to the **MAIN TEST SCREEN**.



Select Tare Mode

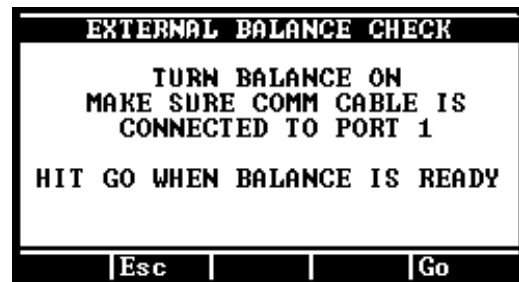

Balance Communication Check



Oval At Bottom Will Show Weight When Communication is Good

14. APPENDIX B - SPECIFICATIONS AND RATINGS

These specifications are intended as a guide to proper use of the instrument. Specifications and features will vary with application. AZI product specifications are controlled by ISO-9001 procedures and are established and verified during design. They are not to be construed as test criteria for every application. Refer to AZI document Number 720-0034, **VAPOR PRO® Fx**, for current specifications. All specifications and features are subject to change without notice. Periodically contact AZI Customer Service at 800-528-7411, or 602-470-1414, or the web site at <http://www.azic.com> to see if any upgrades are available for your instrument.

Dimensions:	Approximately 150 mm (5.75") x 370 mm (14.5") x 360 mm (14")
Weight:	Approximately 8.6 kg (19 lbs.)
Power Ratings:	100 - 120 volts 50/60 Hz, 1 amp standby or 8 amps heat on, or 220 – 240 volts 50/60 Hz, 0.5 amp standby or 4 amps heat on.
Environmental Requirements:	5 to 40 °C, 0 to 80% RH, non-condensing, 2000m max altitude, indoor use. Optimum results are obtained from 20 to 40 °C.
Heating Range:	25 °C to 200 °C, electronically controlled in 1 °C increments.
Heater Control:	Temperature controlled to ± 1°C of set point
Lower Detection Limit:	0.1 microgram water
Special Service Carrier Dry air:	Dry nitrogen or dry air (-40 °C dew point, or lower is suggested) at 12 to 20 psig, user supplied or the Dry Air Generator AZI P/N Y990-0143.
Rear Panel Connections:	Parallel printer port (PC standard) 9 pin RS-232 (9600, N, 8, 1) 9 pin balance comm. (proprietary protocol and cable) Power cable receptacle with interference filter Carrier dry air inlet barb fitting Carrier dry air outlet barb fitting Tested sample drain barb fitting
Side Panel Connections:	PC keyboard DIN socket
Resolution:	0.1 micrograms, 0.1 ppm, 0.0001 %
Repeatability:	Depends on sample properties and syringe technique, typically CV is less than 10% for moisture levels greater than 0.1% and 15% for moisture levels below 0.1%
Automatic Test Ending Method:	Rate Threshold, user adjustable Time, user adjustable Time then Rate, user adjustable
Certifications	US and Canadian Underwriters Laboratory European Communities CE Arizona Instrument LLC is an ISO9001 Registered Company

15. WARRANTY

Arizona Instrument LLC warrants the Computrac® **VAPOR PRO® Fx** to be free from defects in materials or workmanship for two (2) years from the date of purchase for those instruments sold in the USA. All international sales normally carry a one (1) year warranty. AZI will repair or replace, at its option, products that AZI determines to be defective during the warranty period. All defective parts replaced by AZI become the property of AZI. Replacement parts are warranted for the remaining portion of the effective warranty period. This warranty does not apply to expendable or consumable items or routine maintenance.

The above warranty does not extend to any product which has been subjected to misuse, abuse, neglect, accident, improper application, modifications or service performed by persons other than AZI's own service representatives; power surges or spikes; negligence in use, maintenance, storage, transportation or handling; or acts of God.

If a **VAPOR PRO®** product is defective in workmanship or materials, the owner's sole remedy shall be repair or replacement of the defective part, or parts, as provided above. Under no circumstances shall AZI be liable in any way to the owner or any user for any damage including, but not limited to, any loss of business or profits or any other direct, indirect, special incidental, or consequential damages, whether or not foreseeable, and whether or not based on breach of warranty, contract, or negligence in connection with the sale of such products. (Some states do not allow the exclusion or limitation of incidental or consequential damages, so the above limitations or exclusions may not apply to you.)

No other warranty is expressed or implied including the warranties of merchantability or fitness for a particular purpose. In no event shall AZI be liable for consequential and/or incidental damages.

The effective warranty begins on the date of purchase by, or lease to, the first end-user (owner). Keep the dated bill of sale, or invoice, for evidence of the effective warranty date when warranty service is requested.

In the event that any questions or problems should arise in the use or application of your Computrac® **VAPOR PRO® Fx** instrument, call AZI Customer Service or your technical sales representative.

Contact Customer Service for extended warranty information.

TRADEMARK AND COPYRIGHT PROTECTION

Computrac[®], **VAPOR PRO[®]**, Arizona Instrument and the stylized AZI are all registered trademarks of Arizona Instrument LLC. Instrument firmware is copyright protected.

All specifications subject to change without notice.

US Patent No. 5,712,421

Other US and Foreign Patents Pending

© Copyright 2002-2011 Arizona Instrument LLC. All Rights Reserved.

Drierite[®] is a registered trademark of W.A. Hammond Drierite Company, Ltd.

Epson[®] is a registered trademark of Seiko Epson Corporation.

Windows[®] is a registered trademark of Microsoft Corporation in the United States and other countries.

Arizona Instrument LLC
Computrac[®] VAPOR PRO[®] Fx Moisture Analyzer
Part Number: 700-0024
Revision K
July 2011

If you have any questions regarding the operation of this instrument, please call for assistance.

Arizona Instrument LLC
3375 N Delaware Street
Chandler, AZ 85225
(800) 528-7411
(602) 470-1414
Fax (480) 804-0656
<http://www.azic.com>

email:

azi@azic.com - General
intl@azic.com - International
support@azic.com - Customer Support