

Installation & Maintenance Instructions

RHEONIK Coriolis Flowmeter

RHE 12

RHM .. NT, ET_x, HT



RHEONIK

Reading Office

Cutbush Park, Danehill, Lower Earley,
Reading, Berkshire. RG6 4UT. UK.
Tel: +44 (0)118 9311188
Email: info@able.co.uk

Aberdeen Office

Unit 6 Airside Business Park, Kirkhill Industrial Estate,
Dyce, Aberdeen. AB21 0GT. UK.
Tel: +44 (0)1224 725999
Email: ab@able.co.uk

Internet: www.able.co.uk
e-procurement: www.247able.com
Registered in England No: 01851002
VAT No: GB 417 2481 61



TABLE OF CONTENTS	Page
<u>Important safety instructions for operating coriolis flowmeters</u>	4
<u>Manufacturer's Liability</u>	5
Typical Applications and Benefits	6
Installation Instructions (in brief)	7
1. General Description of System	
1.1. The Flow Measurement System	8
1.2. Dimensions of Transmitter Casing RHE12	9
1.3. Dimensions of Sensor RHM	9
1.4. Installing Transmitter RHE12	9
2. Assembly and Installation	
2.1. Installation Instructions for measuring Sensor RHM	11
2.2. Heating / Filling of a Sensor (Flowmeter)	14
3. Electrical Connection of RHM	
3.1. Cable Specifications	15
3.2. Wiring between the measuring Sensor and the RHE12	15
4. Installation of the RHE 12	
4.1. Connecting the Power Supply	17
5. Operation and Programming	
5.1. Basic Operation and Settings Principle	18
5.1.1. Startup Display	19
5.1.2. Measurement Display	19
5.2. User Setup	20
5.2.1. Resetting the Mass Totalizer	20
5.2.2. Zeroing	20
5.2.3. Measurement Value Damping	20
5.2.4. Rate and Quantity Unit Display	21
5.2.5. Low-flow Cut-off	21
5.2.6. Allocation of Analog Output Function	21
5.2.7. Span Analog Output	21
5.3. Basic Settings	22
5.3.1. Scaling-M	22
5.3.2. Scaling-D	22
5.3.3. Device Hi-limit Range	22
5.3.4. Temperature Compensation	23

TABLE OF CONTENTS	Page
5.4. Diagnostics Display Primary Sensor Signals	23
5.4.1. Diagnostics-Measuring Frequency	23
5.4.2. Diagnostics-Analog Output	23
5.4.3. Diagnostics-Pulse Output	24
5.4.4. Sensor Diagnosis	24
5.4.5. Display Run-Time Counter	24
6. Zeroing Procedure	25
7. Error Diagnostics	26
8. Adjusting the RHE12 Transmitter	27
8.1. Setting the Frequency Divider, Pulse Output and Measuring Frequency	27
9. Troubleshooting	29
9.1. Error status of output	29
9.1.1. Pulse Output	29
9.1.2. Current Output	29
9.2. Notes on Troubleshooting	29
9.2.1. No Display available on the Device	29
9.2.2. Error Display "Pickup Error"	30
9.3. Notes on Troubleshooting	31
10. Technical Data-Transmitter	32
11. Transmitter Spare Parts	33
12. Technical Data-Measuring Sensor	33

ANNEX:

- A** Wiring diagram RHE 12, RHMxx
 Wiring diagram RHE 12, RHE 15 (profibus adapter)
 Wiring diagram RHE 12, RHM xx (free cable ends)
- B** Display-Matrix
- C** Ex-Safety Instructions
 EC-Declaration of Conformity
- D** Using the HART® Communicator / SENSCOM Program
- E** Using the HART® Communications-Protocol / Command Specification
 (NOT PART OF THIS BOOKLET – ask your Representative for supply if needed)



Important safety instructions for operating coriolis flowmeters

Please ensure that the following safety guidelines are observed at all times

- When installing the appliances in hazardous areas, please observe the relevant local installation regulations.
- The flowmeters are made for a variety of applications and in compliance with international standards. The operating conditions for the appliance are stated on the serial number plate and must be observed at all times.
- Where heated measuring sensors are concerned, sufficient thermal insulation should be provided to ensure that the entire measuring sensor is always kept at the operating temperature.
- Please ensure that no rapid changes in the measuring instrument temperature are caused by the measuring medium and observe the instructions given in this manual.
- If the appliance is to be installed outdoors, and most notably in warmer climates, weatherproof protection will need to be installed for the transmitter in order to protect it against the impact of direct sunlight.
- The maximum permissible pipeline pressure for the measuring sensor can be found on the serial number plate. When using piston pumps, always remember that no pressure peaks should be allowed to emerge which are above the maximum permissible pressure level. Prior to delivery, the measuring tubes are subjected to an overpressure test which is performed at 1.5 times the permissible operating pressure.
- We wish to point out that the abrasive medium may reduce the wall thickness of the measuring tubes and consequently lower the maximum operating pressure.
- The construction material that comes into contact with the medium can be found on the serial number plate. The manufacturer assumes no responsibility for the corrosion resistance of the measuring instrument with regard to the medium to be measured.
- Should the stability of the material that has been moistened by the medium be in doubt, we recommend that you check the wall thickness of the measuring tubes from time to time.
- GE assumes no liability for the loss of production and/or consequential damage unless this has been expressly agreed upon.
- Measuring sensors for liquid foodstuffs and luxury foods or for pharmaceutical usage must be completely scavenged before being used.
- By way of avoiding electrostatic charge, the window on the transmitter may only be cleaned using a moist, antistatic cloth.

- When used in hazardous areas, never open the transmitter casing while the power supply is connected.
- Only certified, type "Ex-d" cable bushings should be used in hazardous areas.
- All unused cable bushings located in hazardous areas must be sealed using certified, type "Ex-d" plugs.

To ensure that the appliances meet the demands of protection class IP66 (as prescribed by EN 60529) following installation, please consider and observe the following points:

- All of the casing screws must be tightened.
- Always use suitable cable glands for the outer diameter of any cables that may be used.
- Tighten the cable glands.
- Unused cable glands must be replaced by plugs.
- Close all of the casing covers tight so that the sealing washers between the casing and the cover are under pressure and sealed.
- The limit values for the maximum permissible medium and ambient temperatures must be observed at all times. The permissible temperature for the measuring sensor can be found on the serial number plate. The permissible temperature for the transmitter is 55°C.



Manufacturer's Liability:

Given the warranties and liabilities accepted by the manufacturer, please note that the measuring instruments may not be utilised in life-preserving systems used in medical applications, or in motor vehicles, aircraft, watercraft or in the mining industry.

In addition, the manufacturer accepts no liability for damage resulting from the improper or non-compliant usage of the appliance.

Liability for consequential damage or loss of production will solely be accepted if the customer expressly requires such liability or if it has been expressly agreed in the sales contract.

Typical Applications and Benefits

For almost 20 years now, RHEONIK coriolis flowmeters have been used by industry to determine the volume of such liquids and gases as:

- Acid, lye, alcohol, hydrocarbons
- Bitumen, fats
- Oils (mineral oil, vegetable oil, synthetic oil)
- Foodstuffs (vegetable oil, beer, liquid yeast, liquid sugar, chocolate, soup, sauces)
- Beverages, flavouring, liquid carbon dioxide
- Lacquers, paint, filling compounds, rubber products
- Fuel (methanol, diesel, petrol, kerosene, methane gas, liquid hydrogen)
- Coolant, hydraulic oil, brake fluid
- Deionized (non-conductive) water
- Animal fodder additives (molasses, rape seed oil, flavouring)
- Pharmaceuticals
- Cosmetics (creams, scented oils, emulsions)
- Polyol, isocyanate, polyester, propellants (freon, pentane, etc.)
- Gas station products (natural gas, propylene, propane)
- Ultra-cold, liquid gases (hydrogen, nitrogen, oxygen, etc.)
- Slurry, suspensions (oil/water)

The advantage of using this patented measuring principle is that it allows for direct mass flow measurement.

Given the rapid reaction time, the appliances are suited to both batch dosing and flow control or monitoring.

The measurement is taken regardless of the pressure, temperature, viscosity, conductivity or flow characteristics of the liquid.

Due to its unique design, the measuring sensor is durable enough not to wear down even after many years of operation and is also a low-maintenance product.

Inside the liquid stream, there are no fittings or rotating parts that could block the flow and consequently lead to a very costly shutdown of the production facilities.

Installing the flowmeter into the pipeline system is easy. No long tube runs in front of and behind the sensor need to be taken into account and the measuring sensor can be mounted almost directly behind turbulence creating elbows or pipe diameter reducers without impairing the accuracy of the measurements.

Measuring media with fibrous content a high solid charge does not pose any real difficulty.

If used in accordance with the instructions, it is, unlike positive-displacement counters, possible to do without expensive filters without actually damaging the measuring sensor.

Measurements can be taken by the measuring sensor irrespective of the flow of the liquid.

Sudden pressure peaks or water shocks in the pipeline will not damage the appliance. In such an instance, other purely mechanical measuring procedures are prone to impeller wheels overtorquing, axles breaking, or bearings becoming displaced, which all result in the measuring device becoming unusable or even blocking the flow of liquid.

GE appliances are calibrated at the manufacturer's site on precision test benches and can be operated directly without the need for local adjustments. A calibration certificate is supplied with the appliance.

Rheonik Installation Quick Guide RHE 12

This is a short form, please read also our Field Manual

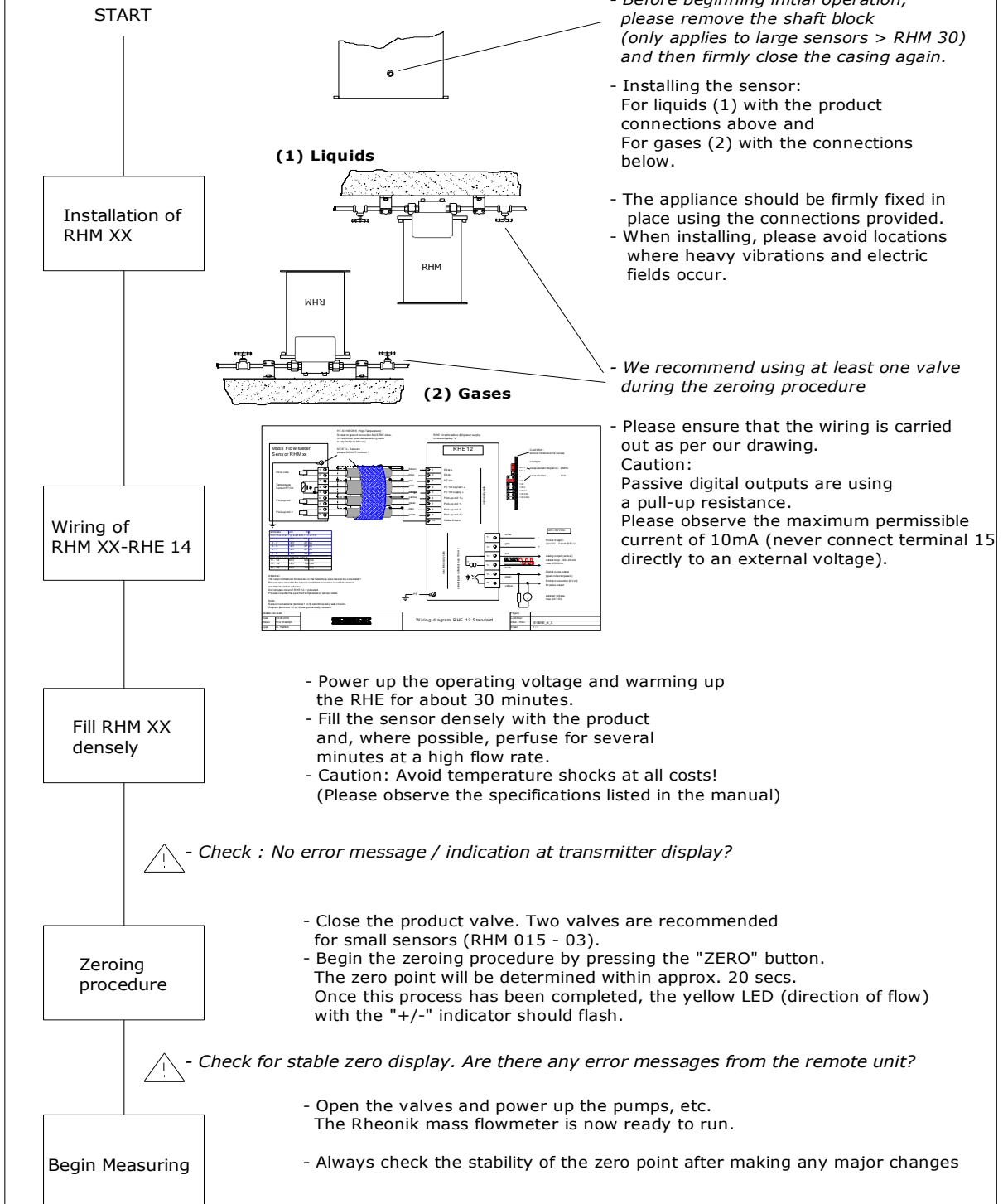

- Before beginning initial operation, please remove the shaft block (only applies to large sensors > RHM 30) and then firmly close the casing again.

- Installing the sensor:
For liquids (1) with the product connections above and
For gases (2) with the connections below.

- The appliance should be firmly fixed in place using the connections provided.
- When installing, please avoid locations where heavy vibrations and electric fields occur.

- We recommend using at least one valve during the zeroing procedure

- Please ensure that the wiring is carried out as per our drawing.
Caution:
Passive digital outputs are using a pull-up resistance.
Please observe the maximum permissible current of 10mA (never connect terminal 15 directly to an external voltage).

- Power up the operating voltage and warming up the RHE for about 30 minutes.
- Fill the sensor densely with the product and, where possible, perfuse for several minutes at a high flow rate.
- Caution: Avoid temperature shocks at all costs! (Please observe the specifications listed in the manual)

⚠ - Check : No error message / indication at transmitter display?

- Close the product valve. Two valves are recommended for small sensors (RHM 015 - 03).
- Begin the zeroing procedure by pressing the "ZERO" button. The zero point will be determined within approx. 20 secs. Once this process has been completed, the yellow LED (direction of flow) with the "+/-" indicator should flash.

⚠ - Check for stable zero display. Are there any error messages from the remote unit?

- Open the valves and power up the pumps, etc. The Rheonik mass flowmeter is now ready to run.
- Always check the stability of the zero point after making any major changes

Installation recommendations v2.1
created by : service.rheonik@ge.com
Changes without notice

1 General Description of System

1.1 The Flow Measurement System

The complete flowmeter system consists of a:

Sensor, type RHMxx

Transmitter, type RHExx

Connection cable

Inside the measuring sensor, there are precision tubes that are energized by an electro-magnetic drive system, which itself is fed by the transmitter, to vibrate at their natural frequencies.

When a liquid or gas flows through the vibrating tubes, it is subjected to additional deflection due to the degree of inertia that is generated. This deflection is recorded electronically by two velocity sensors and a high-precision electronic time delta.

This measured quantity is proportional to the mass flow rate. A further conversion into physical units is done in a purely digital manner using a signal processor in the transmitter. At the same time, all of the appliance's functions are constantly monitored. Should any disruptions occur, all of the errors that have occurred are immediately reported in the display.

The transmitter has a 4 to 20 mA analogue output with programmable span, which is proportional either to the measured mass flow rate or the temperature; it also has an impulse output that supplies mass-proportional impulses.

All of the outputs and measuring functions can be verified at any time by the user by using the diagnostic mode in the appliance. The maintenance or new calibration intervals can be monitored via a run-time counter.

For service or repair purposes, the transmitter and flow sensor can be replaced independently of each other. This significantly reduces the costs of spare parts for the installed flow sensor/transmitter.

During the factory calibration, the mass flow sensor can be calibrated independently of the transmitter. All sensor-specific calibration data can be programmed using magnetic switches located on the front panel.

To achieve this, the instrument does not need to be opened. All of the relevant data is buffered in a non-volatile semiconductor device (EEPROM).

1.2 Dimensions of Transmitter Casing

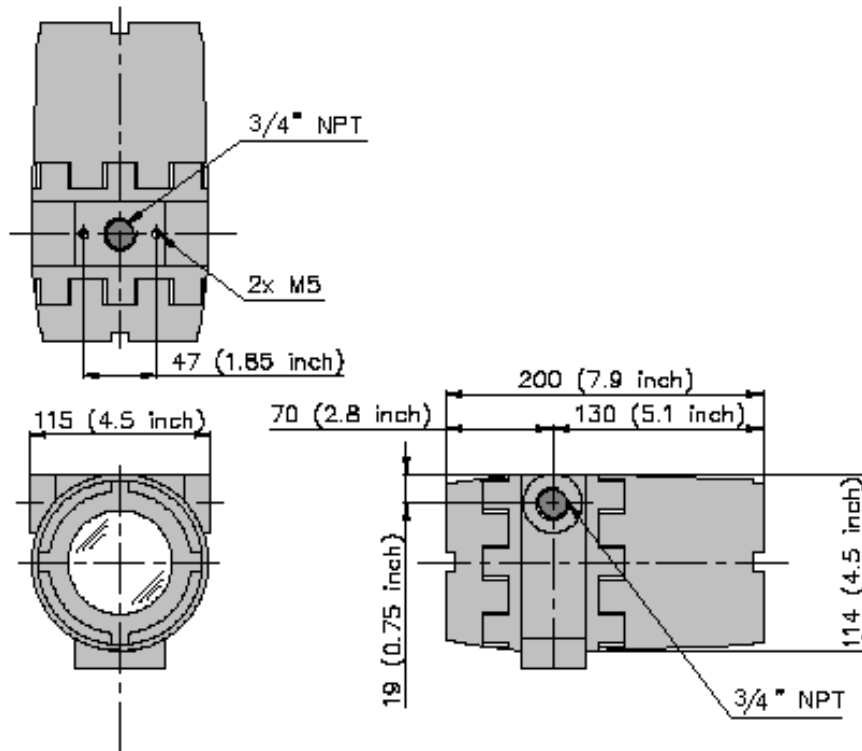

1.3 Dimensions of Sensor RHMxx

The dimensions can be found in individual data sheets, irrespective of the application of the sensor. Data sheets or exact drawings for customized products can be obtained from the dealer or the manufacturer.

1.4 Installing the Transmitter

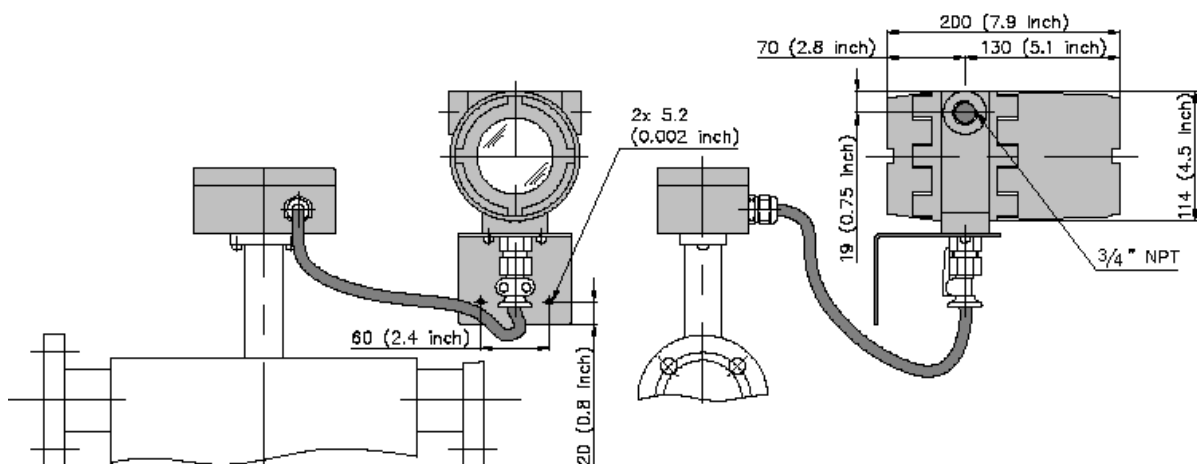

Wiring Instructions:

Never install or wire the appliance while it is connected to the power supply.

Always ensure that you connect the ground wire.

Always observe the permissible voltage stated on the serial number plate of the appliance.

The cable screens should be connected as shown on the connecting diagram. Special care must be taken to ensure that the cable screens on the measuring sensor do not come into contact with the measuring sensor casing (earthing connector) unless otherwise prescribed.

The recommended maximum length of cable between the measuring sensor and the transmitter is 5 meters.

Never allow cable bushings located between the measuring sensor and the transmitter in the switch cabinets and the cable ducts to run alongside leads carrying high electric current from electric machinery or inductive switch elements (electro-motors, frequency inverters, phase controllers, high-performance contactors, electric heaters, choke coils, etc.). Always maintain a minimum clearance of 1 meter.

Never run the measuring sensor cable close to magnetic field sources such as electrical heating coils, transformers or electric motors. The cable screen cannot act against magnetic fields.

Always check the potential equalization between the transmitter casing and the measuring sensor casing.

The cable used at the measuring point must always be temperature resistant. If necessary, use a high-temperature cable between the sensor and the terminal box.

Securely screw down the terminal box once it has been installed (to avoid corrosion, moisture-related short circuiting) and ensure that suitable cable glands are used that have been adequately sealed.

**Important for trouble-free operation**

Both the RHM transmitter and the measuring cable (RHM/RHE) must be installed as far away as possible from any sources of electrical interference (transformers, high-voltage switch elements, large electric motors, frequency inverters, etc.).

2 Assembly and Installation

2.1 Installation Instructions for Measuring Sensor RHM

The direction of flow through the measuring sensor is bi-directional. The pipeline next to the measuring sensor should be rigidly mounted as closely as possible to the hydraulic connectors using pipe clamps.

Any unsecured sections of the pipeline situated near the measuring sensor that might be caused to vibrate should be avoided at all costs.

Due to the construction of the measuring sensor and the digital measuring filter of the signal processor, it is possible to minimize the amount of interference caused by vibrations in the system.

Nevertheless, heavy vibrations can result in the measuring accuracy being significantly impaired and, in certain circumstances, in the measuring sensor being damaged. The critical frequency range is between 50 and 300 Hz.

It is recommended that you install the measuring sensor at a point that vibrates as little as possible.

A good decoupling requires having solid pipe clamps and a place of installation with a rigid surface.

Where liquids with a low vapour pressure are concerned, the system pressure on the entry side of the measuring sensor must maintain a certain safe gap above the vapour pressure as otherwise measuring sensor cavitation may result which could significantly impair the accuracy of the measurements. Where necessary, a pressure regulator should be installed downstream from the sensor.

Once the flowmeter has been installed, the measurement system will need to be zeroed. In order to ensure the accuracy of the measurements, this must be performed under full operating conditions with the measuring sensor filled. Only non-leaking, high-quality valves can ensure absolute zero flow during the zeroing procedure. In the majority of cases, simply switching off the pump will not be sufficient.

For liquid measurements with solid particles, with a particle diameter of 0.5* inside diameter for the measuring tubes (see pipe dimensions on the serial number plate of the measuring sensor), a liquid filter will need to be installed upstream from the measuring sensor.

A gas filter must be installed for gas measurements with abrasive particles in the stream (e.g. rust particles) in order to avoid any damage (abrasion) occurring to the measurement tubes.

For liquid measurements, the RHM transmitter should be installed at a low point in the pipe system as this will prevent gas bubbles from forming in the sensor.

Avoid heavy shocks or rapid acceleration in the measuring sensor. The measuring sensor should be installed in such a way that it can be kept at the same temperature for virtually the entire time.



When using large-sized measuring sensors, always ensure that the shaft block is removed before start-up and the orifices have been sealed tight again.

Example of System:

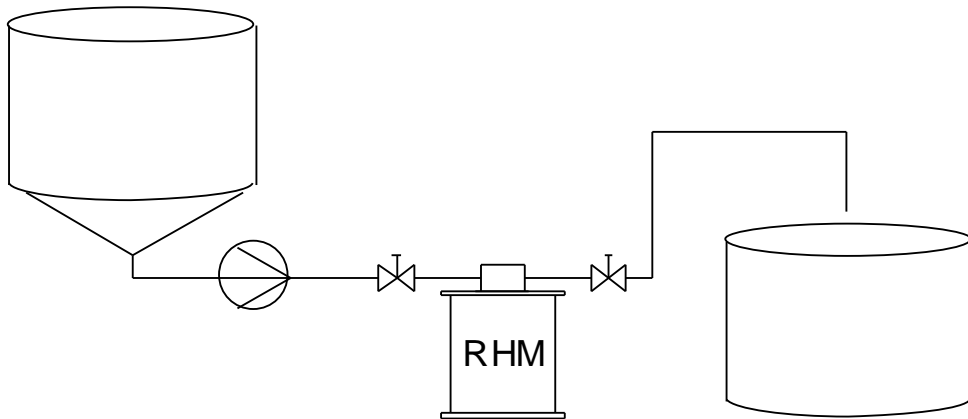

At this point, the pipe system must be as free as possible from all vibrations. In principle, standard buildings or system vibrations have no significant impact on the accuracy of the measurements. Nevertheless, very heavy vibrations should be avoided at all costs.

Please observe the following information on where to install the sensor.

Installation Plan

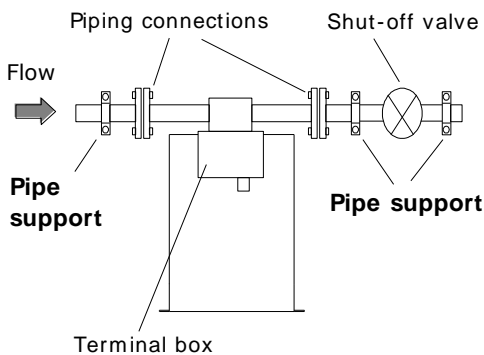

To measure the liquids, a sensor should be installed in such a manner that the pipeline connections are located upstream and the casing faces downwards (see drawing); where gases are concerned, the sensor should be installed with the pipeline connections pointing downwards (with the casing pointing upwards). The sensor should be filled to the top with the medium in question. In doing so, all of the gas bubbles must be removed entirely from the appliance before start-up. This can be achieved, for example, by rinsing the pipes for several minutes at a high flow rate.

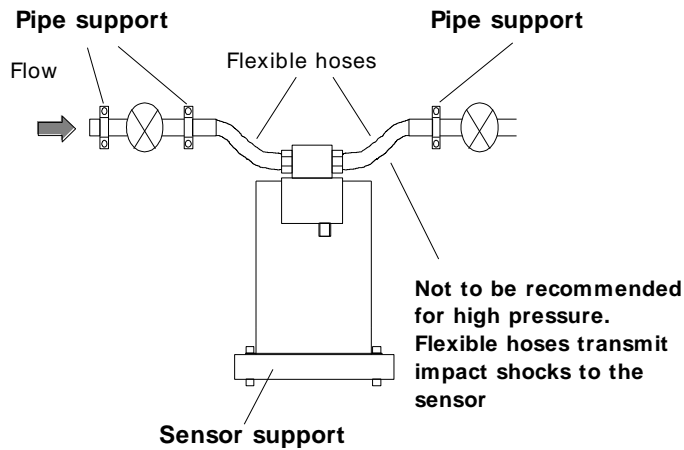

It is also possible to install flexible hoses. However, impact shocks are transmitted to the measuring sensor as a result of the setup of the hoses which may interfere with the measurements at high pulsating pressure levels.

This type of installation should be seen as an alternative in the event that it is not possible to mount the unit onto the pipe suspensions.

If flexible hoses are connected directly onto the sensor, the flanges on the casing may be used to affix the sensor.

To ensure a stable zero point, the sensor must be permanently installed at all costs.

For lower measurement ranges in liquids (5-30% of the final range), sensors **RHM 30, 40, 60, 80, 100, 140 und 160** may be installed in a virtually horizontal position (parallel to the ground).

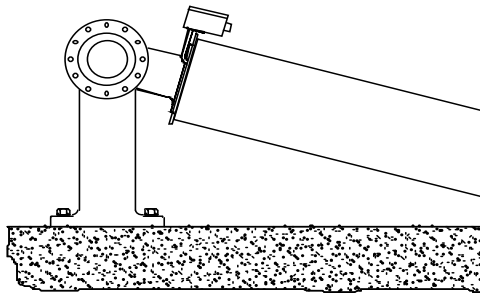

When installed in this position, the flanges of the casing can be used to mount the unit. In either case, the sensor and/or pipeline must be mounted in front of or behind sensor RHM. Ideally, rigid pipe systems should be used. Avoid drastic reductions as these can result in cavities forming inside the measuring tubes. Where necessary, any reducers should be installed several meters away from the measuring instrument.

For sensor sizes **RHM 30 to 160 with parallel tube loops**, straight pipe sections must be provided for before and after the sensor **if the medium is fed from a clearly different axis** than given by the inner pipe bend of the sensor.

For the afore-mentioned sensor designs, we recommend that, for the down flow, straight piping of between 3-5 times the diameter of the pipe should be used and, for afflux, piping of between 5-10 times the pipe diameter should be used in order to avoid significantly different flow velocities resulting for the two measuring tubes.

No valves or reducers should be installed between the pipe suspension and the sensor.

First-rate valves should be installed on the outflow side to ensure that the zero point can be set without difficulty.

Where the smaller **RHM 015, 03 and 04** sensors are concerned, it is important that two valves are installed, one each before and after the sensor. As the pipelines have proven to be very instable here, we recommend that you additionally secure these sensor sizes to the pipe suspension (feed block). To this end, GE offers an aluminium bracket that ensures a perfect and simple means of installation.

Installation Plan with Bracket (Side View):

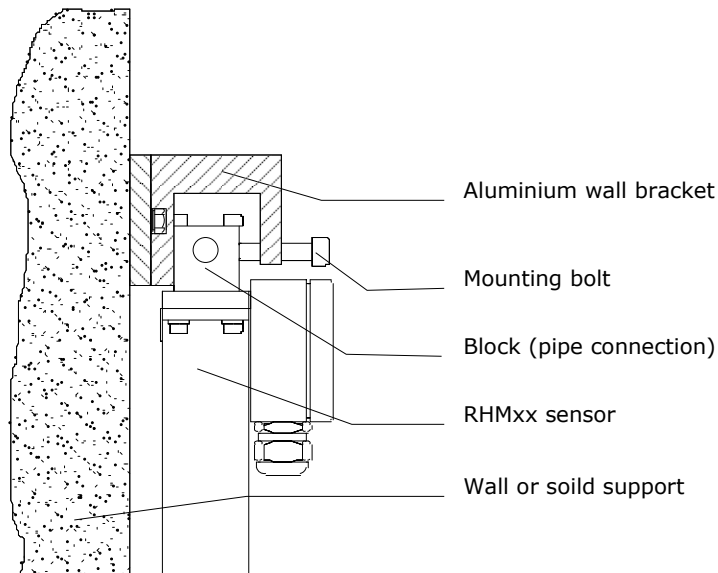

Important Note on the use of High-Temperature Flowmeters (Type RHMxx ET2 and HT):

2.1.1 Heating / Filling a Sensor:

The measuring sensor should be heated slowly so that the temperature differential between the medium and the sensor is less than 50°C.

By way of monitoring this, the temperature in the sensor is shown directly on the RHE display. **Rapid heating or cooling cycles are not required** at all during the service life of the mechanical appliances.

Caution: Temperature shocks may result in damage occurring to the electro-mechanical components in the sensor. When changing temperature, we recommend a velocity of less than 1°C per second.

Example: Sensor temperature: 310°C; temperature of medium: 340°C;-virtually the ideal scenario for filling.

Purging: When scavenging with a cleaning agent, always ensure that the aforementioned recommendations are observed.

3 Electrical Connection of RHM

3.1 Cable Specifications

The following types of GE special cables are recommended as wiring cables to be used between the measuring sensor and the transmitter and can be readily ordered from the manufacturer:

Type 1:

Standard cable – suitable for all appliances

- Permissible cable temperature range: -20 ... + 70°C
- 9 core, 4 pairs, individually screened and one wire unscreened
- Material: PVC
- Colour: Light blue
- Outer diameter: 12 mm

Type 3:

High-performance cable – suitable for all appliances

- Reinforced steel
- Permissible cable temperature: -40 ... + 70 °C
- 4 pairs of wires and 1 x 3 wires, individually screened
- The two wires for the drive circuit have a specifically low ohmic resistance
- Material: PVC
- Colour: blue
- Outer diameter: 16 mm

3.2 Wiring between the measuring sensor and the RHE12

The RHMxx sensor should be connected to the RHE12 transmitter using a 9-core screened special cable.

It is very important to remember that the functional groups of drive coils and tapped coils are kept separate (each one should have two jointly screened cores; see also enclosed wiring schematic).

This will prevent the drive signals from attenuating onto the pickup wires.

The maximum distance between the sensor and the RHE12 transmitter is 5 meters.

Ideally the corresponding measuring cable supplied by GE should be used. In addition, we recommend that, when laying the measuring cable, you should only use cable ducts where no high-voltage or heavy-current cables have been laid (e.g. for motors).

Make sure that the wiring points are not connected to external systems such as motors or other sources that are prone to electrical interference.

Also ensure that the cable screens cannot cause a short circuit of the sensor casing or any other leads or parts. A conductor is used to connect RHE12 terminal No. 10 (galvanically separate zero point inside the appliance) with the sensor (see also enclosed wiring schematic). All of the screens are also connected to this electronics terminal.



Notes on RHMxx Type NT and ETx

Where **NT** and **ETx** sensors are concerned, the main screen and the single screens are **solely** connected to **RHE12** using **terminal 10** (galvanically separate zero point inside the appliance) and **not to the sensor** but clipped and insulated at this point.

Taking this step will prevent potential equalization from flowing through the measurement cable which may affect the measurement.



Notes on RHMxx Type HT

For all RHM high-temperature sensors type HT (ceramic insulation), an additional potential equalization lead must be laid between sensor RHMxx HT and transmitter RHE – terminal 3 to compensate for hygroscopic conductivity in the ceramic construction materials that are used.

This lead will need to be laid on clean ground.

The measuring cable screen is **only connected** to the earth screw of the sensor if high-temperature sensors are used.

Circuitry:

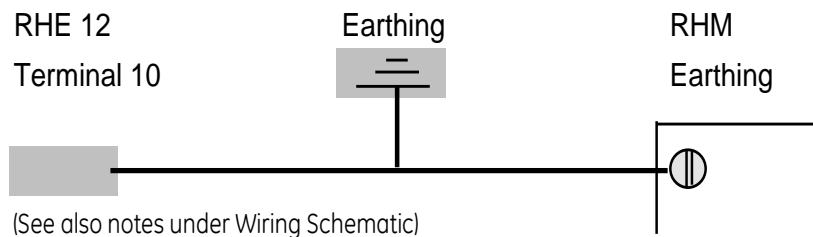

Notes on intrinsically safe installation:

Only appliances with the relevant name plates of the sensor and the transmitter are in compliance with the data specified in the licence.

Intrinsically safe flow measurement instruments must be connected in compliance with the enclosed wiring schematics.

Please ensure that the appliance is earthed as per the regulations and in compliance with the enclosed wiring schematics.

The sensor cable must also be suited for use in the relevant temperature range.

All intrinsically safe cables must be laid separately from all other cables. Ensure that they correspond to the relevant temperature category and the maximum permissible sensor temperature, which is also specified on the serial number plate of the sensor. All of the electric connections performed by the user must comply with the national and local regulations.

4 Installation of the RHE

The RHE transmitter should be installed in locations where the ambient temperature ranges from between -20 and +60°C. For temperatures outside this range, please consult the manufacturer.

Avoid installing in places which are subject to extreme vibrations. Furthermore, the transmitter must not be exposed to direct sunlight.

The RHM sensor and RHE transmitter are calibrated by the manufacturer as one system. Please therefore ensure that the serial numbers tally with the relevant measuring unit stated in the calibration certificate or on the serial number plate.

4.1 Connecting the Power Supply

The RHE 12 transmitter is equipped with a 24 VDC mains supply.

For trouble-free operation, the power supply must maintain the specified nominal voltage of +/- 10%.

When connecting the transmitters, always ensure that the power supply is switched off. The earthing for the power supply should be connected using the relevant RHE earthing.



Caution: Wrongly connecting the earthing will disable the intrinsically safe features!

All outputs are galvanically separated from the auxiliary power and gating circuit.

5 Operation and Programming

This section deals with the operation of and settings for the RHE12 transmitter.

5.1 Basic Operation and Settings Principle

Two magnetic switches and a twin-line LCD each consisting of 16 characters are located on the transmitter.

The delivered magnetic sticks are for activating the magnetic switches.

By holding a stick against the window pane, over the places where the arrows at the front foil are marked, the switch will be activated. It is not necessary to look for the magnetic polarization of the magnetic sticks, since the magnetic switches are realized by bipolar HALL-sensors, they will work bidirectional.

Using the switches, it is possible to set every single operating parameter or to activate the appliance functions.

- Measurement range
- Analog output span
- Physical units
- Low-flow cut-off
- Diagnostic functions for measurement and output
- Flow measurement calibration
- Automatic zeroing
- Measurement damping
- Totalizer reset
- Run-time counter reset

The transmitter is operated through the menu. Once in the menu, the current functions of the two magnetic switches are displayed in the LCD display.

If the letters SET appear in the display over the key located below it, activating this key will set the parameters or activate the reset.

Pressing NEXT will take you to the next menu point in the display.

To reach the basic set-up, which helps to adjust the transmitter to the relevant measuring sensor, press both magnetic switches for a few seconds at the same time.

All of the settings are saved in a non-volatile EEPROM memory that guarantees data security for a period of over 10 years.



Important Note!

Prior to delivery, the values in the basic set-up are calibrated by the manufacturer for the relevant measuring sensor in accordance with the serial number plate of the transmitters and do not need to be programmed. Changing these values can significantly impair the accuracy of the measurements and should only be performed by trained users or in consultation with the nearest GE-service centre.

To access the applications set-up, activate the right-hand magnetic switch (in the measurement data display) for approx. 5 seconds. With the help of the menu steps that follow, the transmitter can be adjusted by the user for his specific application.

To activate Diagnostic Mode, activate the left-hand magnetic switch (in the measurement data display, also for 5 seconds). This enables you to check the key functions of the measuring instrument prior to its initial operation.

5.1.1 Start-up Display

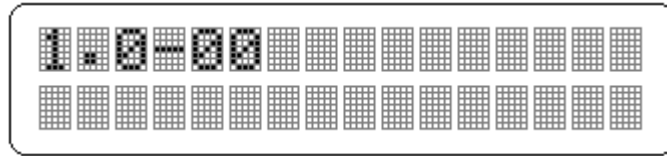

After power up, the start-up display will show the program version number and the appliance address (0 to 15) for the serial data interface for a period of 5 seconds. The appliance address should normally be set to "00". If several appliances are operated in parallel on one serial data interface, you will need to allocate various appliance addresses.

5.1.2 Measurement Display

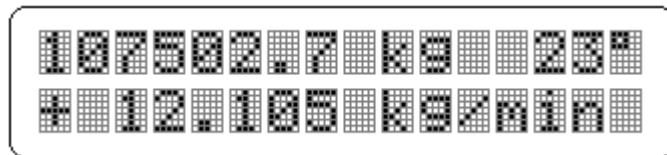

The following measurement values can be read of the local transmitter display:

- Current flow rate display (lower display line)
- Current direction of flow +/- (lower display line, left)
- Current mass totalizer level (upper display line)
- Current sensor temperature (upper display line, right)

The mass totalizer units are shown in Si units kg, t (kilogram, tonne) or in the US unit lb (pounds).

The flow rate units are given as kg/min, kg/h, t/h or lb/min.

The temperature units that are displayed are °C (Celsius) or °F (Fahrenheit).

5.2 User Set-up

To access the User set-up, activate the right-hand magnetic switch for approx. 5 seconds.

5.2.1 Resetting the Mass Totalizer

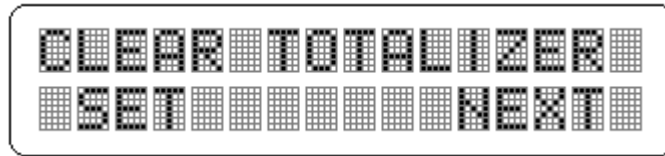

The mass totalizer will reset to Zero if the SET key is pressed for 5 seconds with the above display showing.

5.2.2 Zeroing

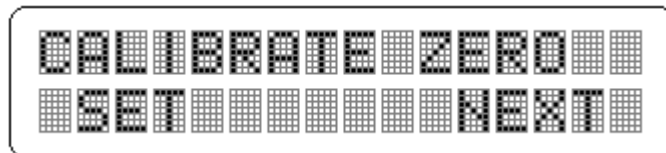

Zeroing is automatically performed if the SET key is held down for approx. 5 seconds.

The actual zeroing process takes about 20 seconds. During this time, the display cannot be used further. The words "ZEROING ACTIVE" will appear in the display.

An exact description of how to perform the zeroing can be found in the chapter entitled "ZEROING PROCEDURE".

5.2.3 Measurement Value Damping

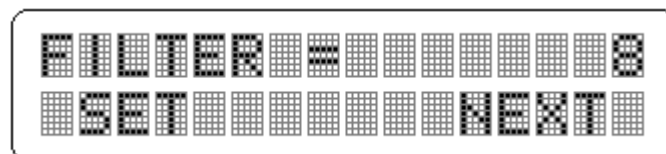

Press the SET key to set the reaction time and various measurement damping values. The numerical value that is displayed indicates that digital filtering is being applied for this number of sequential measurement values.

5.2.4 Rate and Quantity Unit Display

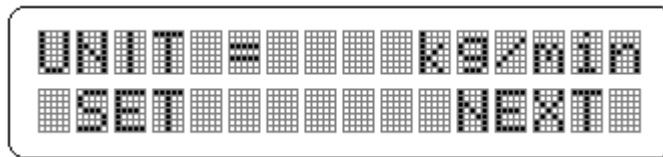

The flow rate and totalizer units can be set using the menu point entitled SET. Regardless of the range that is set, the following units can be selected: g/min, kg/h, t/h. The totalizer display automatically sets to kg or t.

5.2.5 Low-flow Cut-off

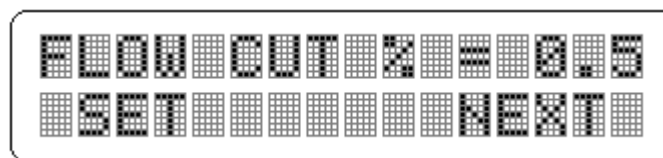

Here, a flow rate can be set as a % of the set RANGE. Below this threshold, no flow rate will be displayed or counted.

5.2.6 Allocation of Analog Output Function

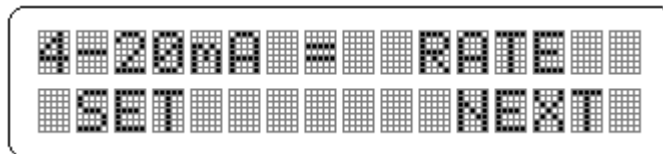

The 4-20 mA output can be allocated either the current flow rate or the temperature.

5.2.7 Span Analog Output

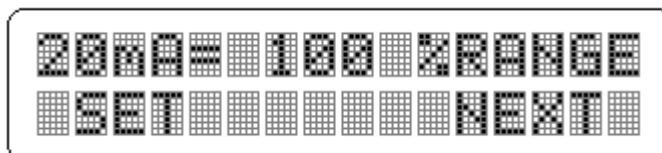

In output mode "Temperature", the 4 to 20 mA span corresponds to -150 °C to +360 °C. In output mode "Flow Rate", the ultimate flow rate value can be set in the next display. Flow rate "Zero" corresponds to 4 mA. The ultimate value of the analog output can be scaled using the SET key. The percentage value relates to the ultimate value of the measurement range in kilograms per second that is set when in RANGE display.

5.3 Basic Settings

With the measurement value display active, press both magnetic switches for approx. 5 seconds to switch to basic settings mode.

The following displays show the settings that have been determined during the manufacturer's calibrations for the connected measuring sensor and which are recorded in the calibration certificate enclosed to your RHEONIK measuring system (the values depicted are solely intended as examples and may vary from those found in your measuring system).

5.3.1 Scaling-M

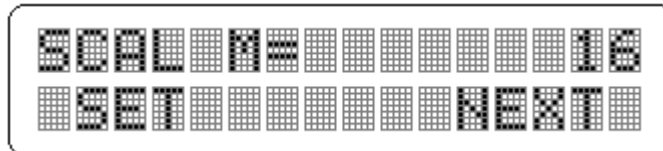

The scaling multiplier for mass flow calibration. The actual valid value for the measuring sensor can be found in the calibration certificate supplied with the appliance.

5.3.2 Scaling-D

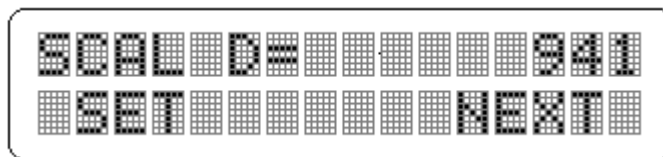

The scaling divider for mass flow calibration. The actual valid value for the measuring sensor can be found in the calibration certificate supplied with the appliance.

5.3.3 Device Hi-limit Range

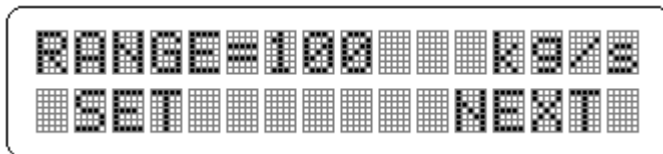

Using the SET function, all of the device hi-limit ranges can be set for flow measurement. To achieve this, the sensor range must be within the displayed RANGE otherwise the words OVERFLOW ERROR will be displayed during operation.

5.3.4 Temperature Compensation

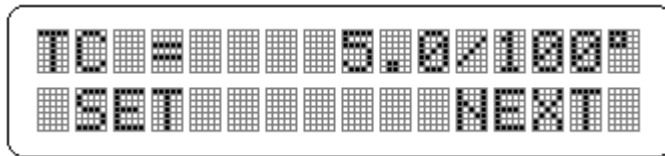

When set, this parameter will compensate for temperature-related changes in the measuring sensitivity of the measuring sensor. The unit applied is %/100°C.

5.4 Diagnostics Display Primary Sensor Signals

The display indicates the current values of the phase shift that has been measured as well as the value of the digital analog converter for measuring temperature

The values range between 32768 ... 32768 or 0 ... 255.

5.4.1 Diagnostics-Measuring Frequency

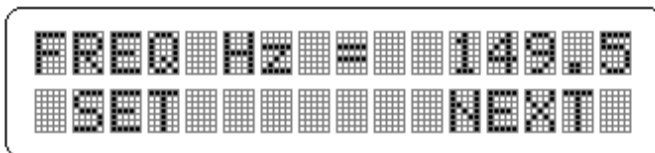

Here, the working frequency of the Coriolis flowmeter is displayed. The value depends on the flow rate sensor and the density of the medium in the measuring tubes.

5.4.2 Diagnostics-Analog Output

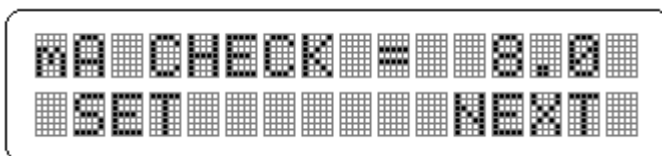

For testing purposes, the SET button can be used to set the output to the pre-set values ranging from between 4 and 20 mA.

The output value can be verified using an ampere meter connected to both terminals 13 and 14.

Pressing both set keys at the same time will switch the Transmitter to continuous test mode. A periodic rising signal will be emitted which ranges between 4 and 20 mA and lasts for around 30 seconds.



Please Note!

The test function described here must not be performed when measurements are being taken if the measuring device is being operated as an actual value transmitter for a closed loop circuit. In this case, the flow rate controller will be sent an invalid actual value signal.

5.4.3 Diagnostics-Pulse Output

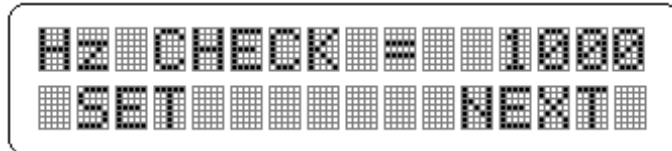

The displayed frequency is indicated when the pulse output is connected if the pulse divider is bridged 1 : 1 in the transmitter electronics. If not, the divider should be taken into account when the frequency is measured at terminals 12 and 13.

5.4.4 Sensor Diagnosis

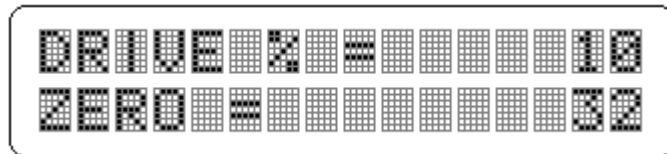

The percentage of power dissipation in the sensor’s drive circuit is shown as is the zero point that is calculated during the sensor zeroing procedure.

5.4.5 Display Run-Time Counter

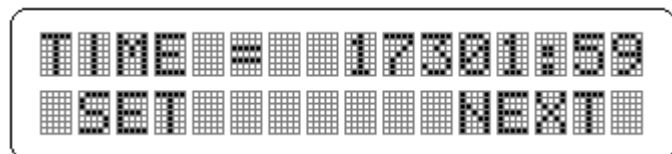

The display indicates in hours and minutes the amount of time the measuring device has been in operation. In the example above, the operating time is 17301 hours and 59 minutes. The SET key can be used to reset the counter.

6 ZEROING PROCEDURE

Once the measuring sensor has been installed inside the pipeline and the transmitter has been electrically wired, a zeroing procedure will need to be run. Zeroing is done with the help of the local display and takes around 20 seconds. Once this is completed, the flow rate measurement system will continue to run on the basis of the newly defined zero point.

How to Proceed:

- Perfuse the measuring sensor with as high a flow rate as possible until the measuring tubes are filled without any gas bubbles/condensation and the unit is running normally.
- Switch off the flow rate.
- Close the check valve in the pipeline for zeroing (ideally downstream from the measuring sensor).
- Using the local display in the zeroing menu (see display matrix) and the SET function, begin the zeroing procedure. While the appliance is performing the zeroing procedure, the words "ZEROING ACTIVE" will be displayed.
- Once the zeroing is completed, the newly defined zero value will be indicated in the display.
- Press NEXT. The measuring device is now ready for operation.
- The zero value that has just been defined is saved to memory and the valve can now be re-opened.



Please Note!

Since the zero point value is buffered to a non-volatile memory (EEPROM), the measuring device will remain ready for operation even if the power supply is shut down and then re-started. No new zeroing is required.

To ascertain whether or not a new zeroing procedure needs to be performed on the measuring device after it has been idle for a long period of time it is possible to compare the values indicated in the display for both PHASE and ZERO (see instruction matrix entitled "Diagnosis"). For this to happen, the flow rate must be shut down and the valve closed. The current phase should tally with the stored value (zero).



If major changes occur, simply re-run the zeroing procedure!

When greater medium temperatures are concerned or the gas content or viscosity is high, the zero point will only change minimally. For this reason, it is recommended that all zeroing procedures are performed under operating conditions.

7 ERROR DIAGNOSTICS

Malfunctions in the operation of the device are detected automatically and immediately by the signal processor located inside the device. An error message is generated as a short text which can be found in the lower display line.

RAM CHECK ERROR:

An error has occurred in the RAM memory. At least one memory cell cannot be written or read properly. When this error arises, the measuring program is subjected to continuous start-up. The device is no longer operational. The problem can only be remedied by replacing the controller board.

IIC-BUS ERROR:

The serial data transfer to non-volatile parameter memory has failed or the memory chip is defective. The problem can only be remedied by replacing the controller board.

OVERFLOW ERROR:

A number range overflow has occurred during calculation of the arithmetic values. To remedy this problem, a check should be performed as to whether the flow rate is not too large for the measuring sensor being used or whether the measuring range that has been set is sufficient.

TEMP. ° ERROR:

At least one of the wires between the PT100 temperature sensor (in the measuring sensor) and the transmitter has been cut or the PT100 sensor is defective. To diagnose the problem, first check the wiring between the transmitter and the measuring sensor. Should the problem still be present, disconnect the PT100 wires connected to the measuring sensor and take an ohmmeter to the measuring sensor terminals and check whether PT100 has been cut. If PT100 is defective, the measuring sensor will need to be sent in to the nearest service centre for repair.

TOTL. OVERFLOW:

An overflow has occurred in the 7-digit totalizer, i.e. the counter has exceeded the figure 9999999 and the count has been reset at zero. To cancel this message, the totalizer must be reset to zero.

8 Adjusting the RHE12 Transmitter

8.1 Setting Frequency Divider, Pulse Output and Measuring Frequency

For the purpose of making these settings, a 14-pole, double-row pin bar has been provided in controller board M 521 (see Number 5 in the figure below) which can house a jumper that defines the dividing ratio. After removing the casing cover and glass window, the pin bar can be accessed from the side of the block of boards without having to disassemble the individual boards.

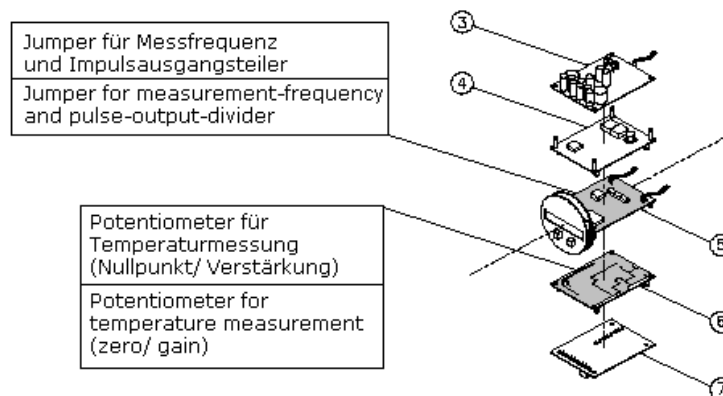

Both the adjustable decade dividers and the relevant position for these can be seen in the following illustration.

The measuring frequency for the phase measurement can be adjusted using a jumper on a 3-pole, single-row pin bar which has been configured next to the pin bar for the pulse divider. Two jumper possibilities are available—as can be seen by the illustration below – one for 4 MHz counting frequency and one for 2 MHz counting frequency. The factory setting can be found in the calibration certificate for the measuring sensor and only needs to be adjusted if the transmitter has not been pre-configured at the factory (replacement delivery). Changing the counting frequency of a calibrated mass flow sensor will result in the output signals changing by a factor of 2 when the counting frequency is changed from 2 to 4 MHz, and by a factor of 0.5 if the change made is from 4 to 2 MHz.

For this reason, in order to correct this, the original value M for the calibration factor of the flow rate measurement will need to be adjusted by changing the setting to half the original value in the first instance and twice the value in the second case.

The table below shows the adjustable pulse settings in line with the RANGE of the transmitter. The set RANGE can also be found in the calibration certificate supplied with the measuring sensor.



For all US units, the number of pulses is given in lbs and not in kg!

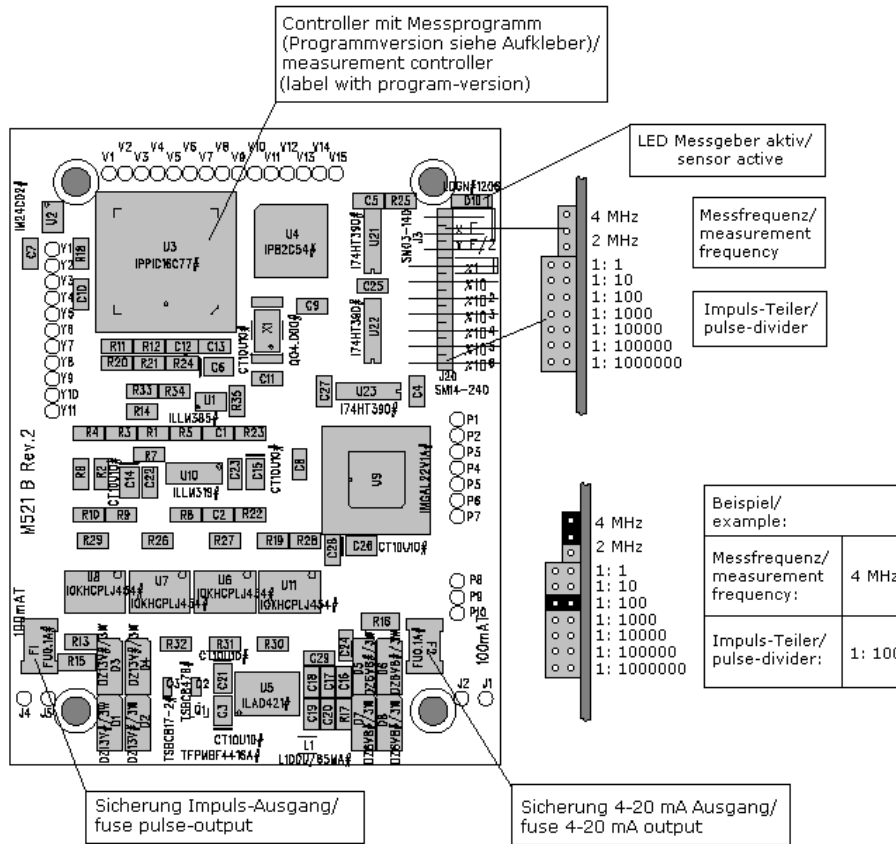

Range	pulses/kg (lb)						
	1:1	1:10	1:100	1:1000	1:10000	1:100000	1:1000000
0 – 0.06 kg/min	10000000	1000000	100000	10000	1000	100	10
0 – 0.6 kg/min	1000000	100000	10000	1000	100	10	1
0 – 6 kg/min	100000	10000	1000	100	10	1	0.1
0 – 60 kg/min	10000	1000	100	10	1	0.1	0.01
0 – 600 kg/min	1000	100	10	1	0.1	0.01	0.001
0 – 6000 kg/min	100	10	1	0.1	0.01	0.001	0.0001
0 – 60000 kg/min	10	1	0.1	0.01	0.001	0.0001	0.00001

On the jumper array for output- divider, **only one divider** may be **bridged** in each case.

9 Troubleshooting



Important Note!

Once the casing cover is removed, the contact voltage proof is disabled which can result in persons being exposed to electric shocks. For this reason avoid all direct contact with the electronic components. All interventions on the device while still connected to the power supply should only be performed by skilled workers using well insulated tools.

Never open the device in a hazardous area when it is still connected to the power supply!

Fuses may only be replaced on the power supply board after the power supply has been disconnected.

9.1 Error status of output

9.1.1 Pulse Output

No pulse output until the error has been corrected

9.1.2 Current Output

The current is set as pre-defined value of 22mA

9.2 Notes on Troubleshooting

9.2.1 No Display available on the Device

Check whether the power supply voltage is within the permissible range: for DC versions the range is 20 to 30 volts on the supply terminals.

Check the fuses on the power supply board using an ohmmeter and, where necessary, replace them with the same type of fuse.

Check whether the LED on the controller board is flashing or not. If yes, the LCD display may be defective or one of the connections to the display board has been cut.

If the problem cannot be remedied, a systems error may have occurred and the device will need to be sent to the nearest service centre for inspection or repair.

9.2.2 Error Display "Pickup Error"

Check whether the measuring sensor has been wired to the transmitter as described in the wiring schematics.

Check whether the following voltage is available for the sensor terminals:

Sensor Terminals	Voltage
1 - 2	approx. 0.25-6 VAC
3 - 4	approx. 113 mVDC (at 20 °C)
3 - 5	as 3 - 4
6 - 7	10 ... 150 mVAC
8 - 9	as 6 - 7

Check whether the resistance values at the sensor terminals can be measured (**Ensure you disconnect the cables to the transmitter in advance**):

Sensor Terminals	Resistance
1 - 2	5 ... 70 Ohm*
3 - 4	approx. 108 Ohm (at 20 °C)
3 - 5	as 3 - 4*
6 - 7	10 ... 160 Ohm*
8 - 9	as 6 - 7*
1,2 .. 9 - casing	> 10 MOhm - ∞

* Resistance values are given for room temperature!

The measured values are very temperature dependent i.e.:

Pick-up coil resistor 120 ohms at 20°C, but 230 ohms at 350°C sensor temperature.

If a circuit is interrupted, a defect must have occurred in the measuring sensor. In this instance, please contact your local GE-Support or start an RMA request and send in the sensor to the service centre for repair. Please describe what defect was detected.



9.3 Important notes on repairs and RMA requests

Please contact GE Measurement & Control; you'll get more information's and a RMA-Number.

Generally:

The sensors must be cleaned.

All residual matter must be removed from the sensor if the measure liquid is poisonous, corrosive, carcinogenic or otherwise hazardous to personal health.

Flow meters used for measuring radioactive matter or that cannot be fully freed of carcinogenic matter may not be sent in for repair.

Should any details on the measured liquid be missing, or if the device has not been sufficiently cleaned, it will not be accepted for repair.

It is recommended that you also send in the transmitter, even if it has no obvious defects. When re-calibrating, both devices can be tested together and exactly tuned to each other. Failing this, it should be remembered that on return of the sensor, the new calibration values for the measuring sensor must be in line with the calibration certificate before beginning the initial operation of the measuring device in the transmitter.

Sensors that are filled with a medium that has hardened at room temperature may be sent in to the manufacturer but cannot be calibrated any more on a test bench.

10 Technical Data-Transmitter

Voltage Supply:

nominal 24 VDC, 20 to 30 VDC, 7 Watt

Casing Material:

Cast aluminium

Protection:

IP66 (EN 60529)

Ambient Temperature:

-20 ... +55 °C

Cable Glands:

¾" NPT Ex-d cable glands

Galvanic Isolation

Outputs against auxiliary energy and measuring circuits

Current Output

4...20 mA adjustable, galvanic isolated, $R_L < 450 \text{ Ohm}$.
Temperature coefficient 0.01% of range /°C
Accuracy: 0.05% of range

Pulse Output Open Collector

$f_{\max} = 10000\text{Hz}$
 $U_{\max} = 24 \text{ V}$,
 $I_{\max} = 10\text{mA}$,
Pull-up resistor required, minimum resistance 500 Ohm at 5V, 3000 Ohm at 24V, galvanic isolated
Hi/Lo ratio 1:1, number of pulses adjustable

Data Backup

EEPROM backs up the parameters in case of a power failure. Backups are made for the totalizer and run-time counter every ten minutes.

LCD Display

2 lines, 16 characters, alphanumeric, font size 5mm

11 Transmitter Spare Parts

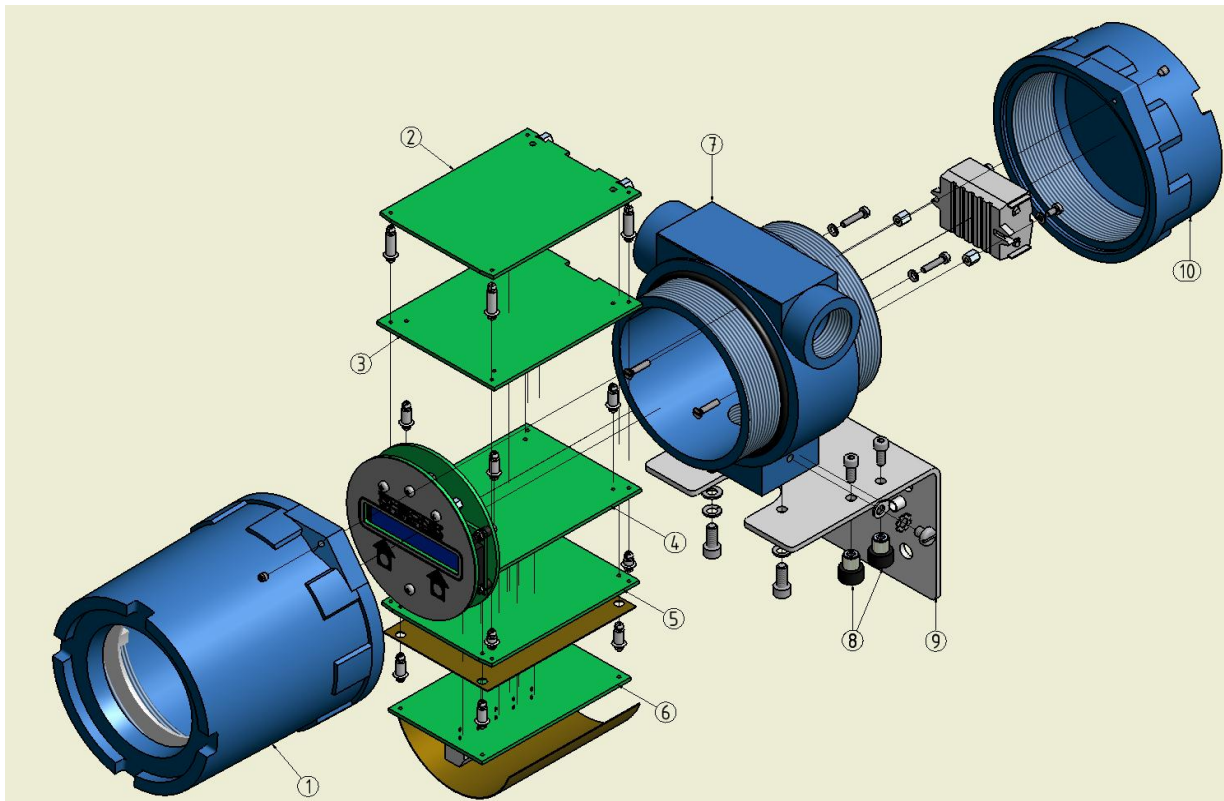

1	Ex-d casing front cover RHE12
2	Power supply board M522
3	HART® modem board M525
4	Display/Controller board M526/527/521
5	Amplifier board M523
6	Safety board M524
7	Ex-d casing, base part RHE12
8	Magnets
9	Wall bracket RHE12
10	Ex-d casing, back cover RHE12

The spare parts listed above can be ordered from the manufacturer or your nearest service centre/repair shop upon request.

Parts may only be replaced by trained personnel. If necessary, contact your local service Contact!

12 Technical Data-Measuring Sensor

The technical data for the measuring sensor can be found in the separate product data sheets.

ANNEX:

- A** **Wiring diagram RHE 12, RHMxx**
 Wiring diagram RHE 12, RHE 15 (profibus adapter)
 Wiring diagram RHE 12, RHM xx (free cable ends)

- B** **Display-Matrix**

- C** **Ex-Safety Instructions**

 EC-Declaration of Conformity

- D** **Using the HART® Communicator / SENSOCOM Program**

- E** **Using the HART® Communications-Protocol / Command Specification**
 (NOT PART OF THIS BOOKLET – ask your Representative for supply if needed)

The following documents shown in this Manual represent the latest respective versions. If you need to make sure it is the most current version, please contact your local GE representative.

The manual inclusive annex is only updated after important or substantial changes.



ANNEX A

Wiring diagram RHE 12 and RHMxx

Wiring diagram RHE 12, RHE 15 (profibus adapter)

Wiring diagram RHE 12 and RHMxx (free cable ends)

RHEONIK the Coriolis Flowmeter experts

HT- SENSORS (High Temperature):
Screen to ground connection MUSTBE done.
An additional potential equalising cable
is required (see Manual).

RHE 12 terminalbox (I/O,power supply)
increased safety "e".

NT/ ETx - Sensors:
please DO NOT connect !

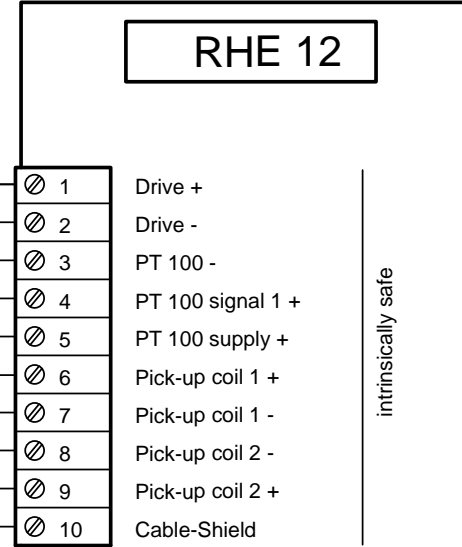
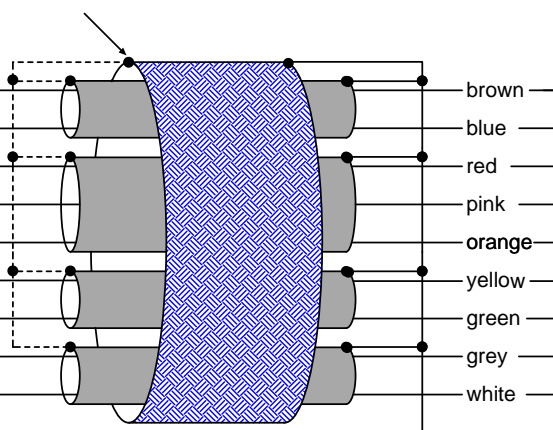
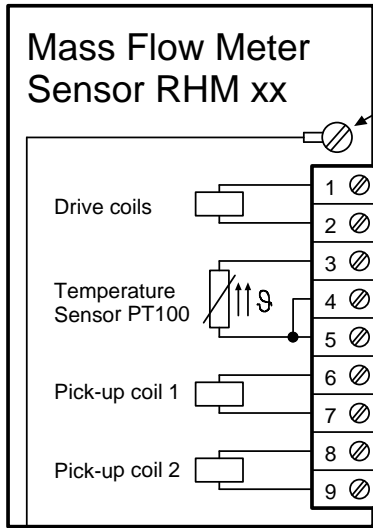

- 1 Drive +
- 2 Drive -
- 3 PT 100 -
- 4 PT 100 signal 1 +
- 5 PT 100 supply +
- 6 Pick-up coil 1 +
- 7 Pick-up coil 1 -
- 8 Pick-up coil 2 -
- 9 Pick-up coil 2 +
- 10 Cable-Shield

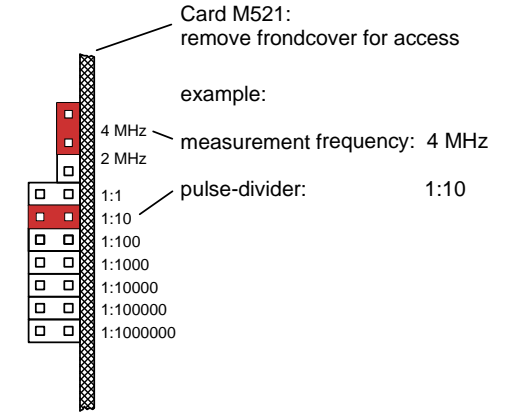

Terminals	Um	Im
intrinsically safe Circuits		
1 - 2	8,6 V	144 mA
3 - 4	7,4 V	27 mA
3 - 5	7,4 V	27 mA
6 - 7	7,4 V	27 mA
8 - 9	7,4 V	27 mA
non intrinsically safe		
11 - 12	30 V	500 mA
13 - 14	14 V	100 mA
15 - 16	26 V	100 mA

Attention:
The local normatives for devices in the hazardous area have to be considered !
Please also consider the special conditions and rules in our field manual
and the respective advises.
Do not open cover of RHE 12, if powered.
Please consider the specified temperature of sensor cable.

Note:
Sensor connections (terminal 1 to 9) are intrinsically safe circuits.
Outputs (terminals 13 to 16) are galvanically isolated.

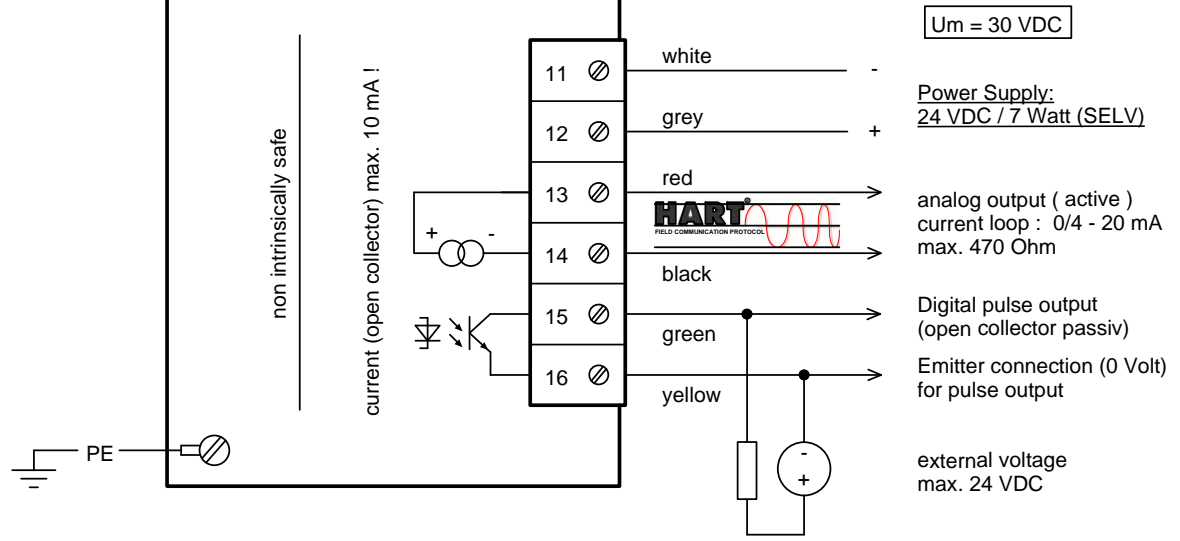

created / revised
Date 03.09.2010
Drawn H.G.Rudolph
Appr. U. Hettrich



Wiring diagram RHE 12 Standard

Project	
Customer	
Draw. - Rev.	E12W-E_v1_3
Sheet	1 / 1

RHE 12 terminalbox (I/O, power supply)
increased safety "e".

----- optional wiring !

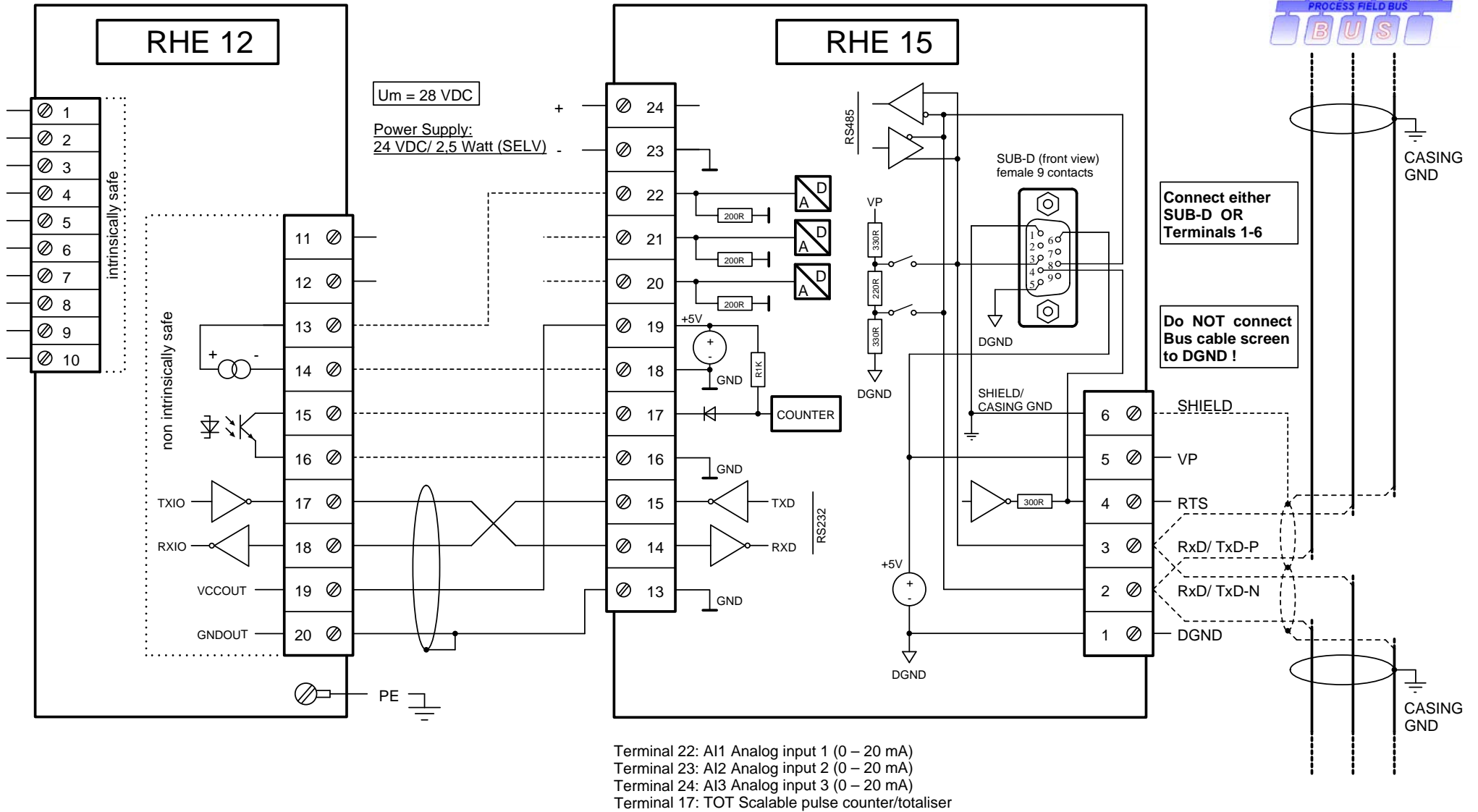

created :
Date 23.10.2006
Drawn H.G.Rudolph
Appr. M. Küppers



Wiring diagram RHE 15 with RHE 12

Project	
Customer	
Draw. - Rev.	E15_12W-E_v1_1
Sheet	1 / 1

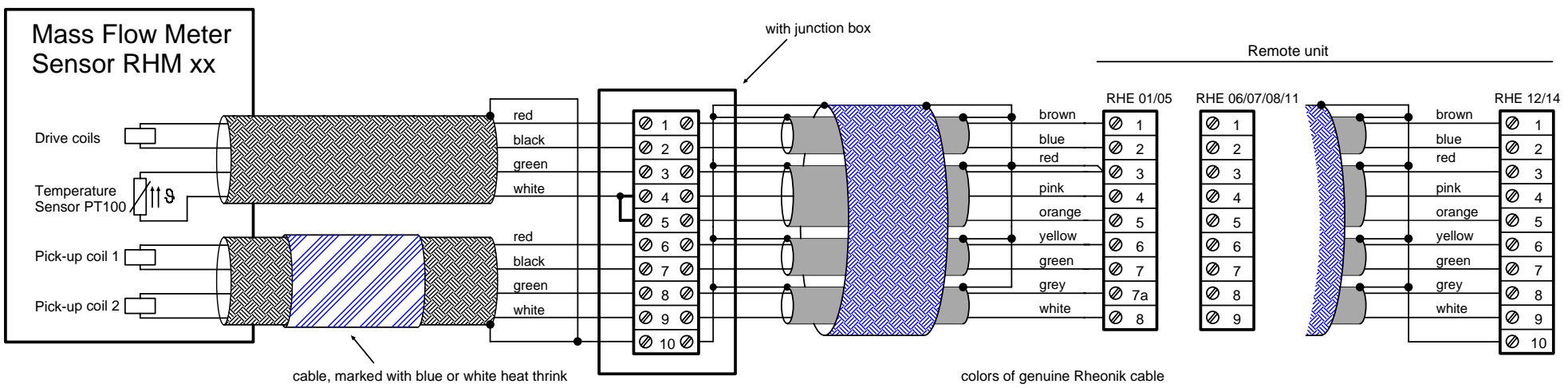
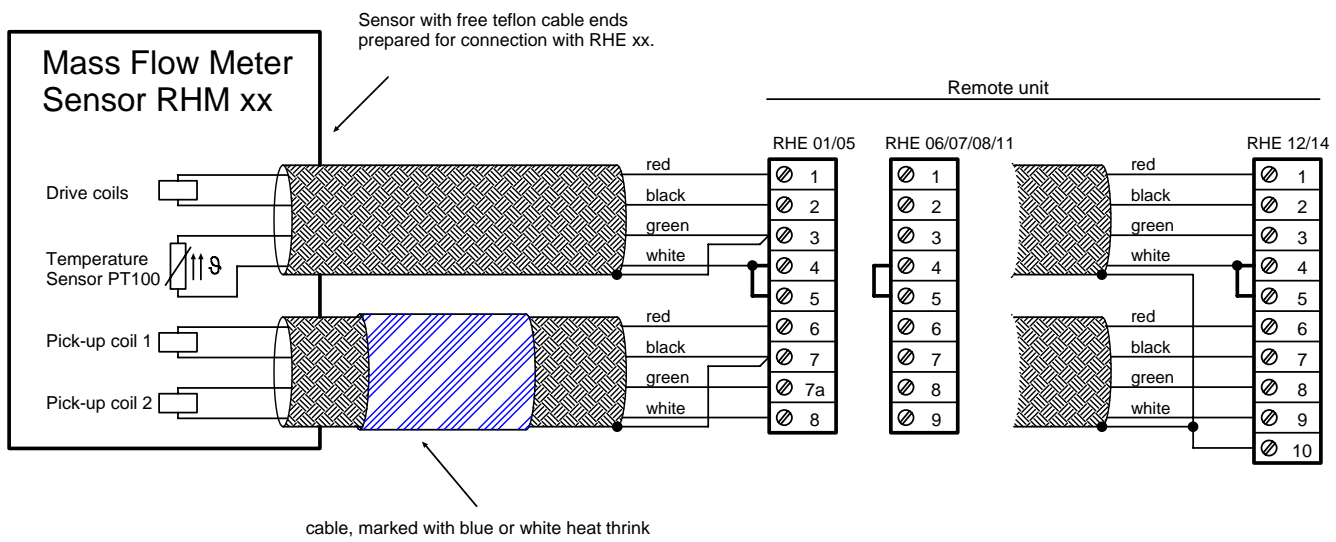

Erstellt :	Änderung :
Datum 17.11.2011	Datum
von H.G.Rudolph	Bearb.
Gepr. U.Hettrich	Gepr.



Wiring diagram RHE XX to RHM XX with free cable ends

Projekt	
Kunde	
Z. - Nr.	EXXWFCE-E_v2_1
Blatt	1 / 1



ANNEX B

Display - Matrix

RHEONIK the Coriolis Flowmeter experts

Display – Matrix

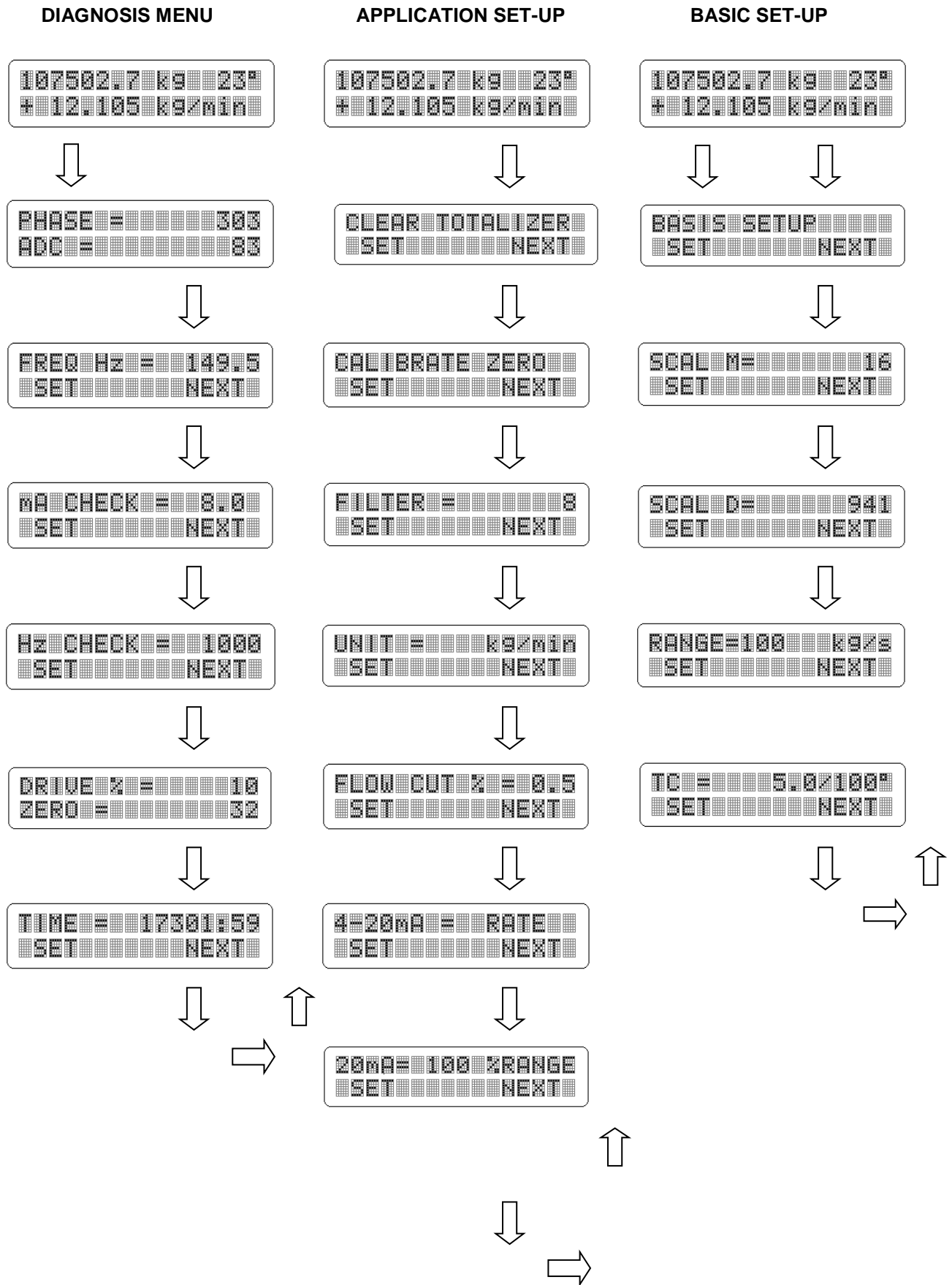



ANNEX C

Ex – Safety Instructions **EC – Declaration of Conformity**

RHEONIK the Coriolis Flowmeter experts

**Safety Instructions for Installing the Device in Hazardous Areas:**

General Description:

The RHEONIK mass flowmeter, which comprises the system components RHM and RHE has been constructed and produced in accordance with the ATEX 94/9/CE guideline and with reference to the following standards: EN 60079-0, EN 60079-1, EN 60079-7, EN 60079-11.

The measuring system consists of a measuring sensor and transmitter that are connected to each other via a multicore electric cable.

The following points should be observed:

- The measuring system should be installed and operated in compliance with the applicable standards relating to electrical installations in hazardous areas.
- Please read the RHEONIK Mass Flowmeter Operation Manual before installing.
- All assembly work, electrical installations, operation and maintenance work must be performed by qualified workers who have been trained in handling products in hazardous areas.
- All national regulations pertaining to the installation, maintenance and repair of instruments in hazardous areas must be observed at all times.
- The required temperature class based on the ambient temperature and liquid temperature must correspond to the values on the Ex nameplate.
- Wherever possible, the device should never be opened. Should you nevertheless open the RHE12 electronics, please ensure that the power supply has been disconnected and allow the unit to cool down for at least ten minutes.
- Never open the device while it is still connected to a power supply.
- Always use a moist cloth or antistatic products to clean the RHE12 dome cover window.
- The cable connection between the RHM sensor and the RHE remote unit is intrinsically safe. Only use cables which are supplied by GE (SLI2Y(ST)Y (4x(2x0.5 mm²)+1x0.5 mm²))
Always consult with GE before using any other types of cables.
- When running the unit at minus 30°C, a steel-reinforced cable must be used: LISO-ST-C-A-Y 2 x (2x AWG 22 PIMF) + 1 x (2 x AWG 18 PIMF) + 1 x (3 x AWG 22 DIMF), blue. Always consult with GE before using any other types of cables.
- The maximum length of cable between the RHM sensor and the RHE12 remote unit is 10 meters.
- If the cable is to be installed close to the RHM sensor, provisions must be taken to ensure that the cable temperature never exceeds 70 °C.
For this reason, care must be taken to ensure that no loose cable lengths are left which may come into contact with the hot sensors surface or any other hot objects.
- In the case of the RHE12, when establishing a power supply and input and output leads, Type Ex-d IIB+H₂ cable glands must be used which have been certified in accordance with to EN 60079-0 and EN 60079-1.
- All unused orifices in the casing must be sealed off using blind union pieces which have been certified in accordance with EN 60079-0 and EN 60079-1.
- Details on the protection class can be found on the EX nameplate (see also "Markings" which can also be found in this manual).
- In accordance with the specifications given on the Ex nameplate, the instruments are suited for areas where inflammable surroundings may emerge as a result of air, gas vapours and dust mixing.

- The instruments are not suited for use in mines.
- The RHM sensor (Protection class: intrinsically safe, ia) may be installed in hazardous areas 0, 1 or 2.
- The RHE12 remote unit falls under protection class: pressure-proof housing, intrinsically safe, d [ia]), and may be installed and operated in hazardous areas Zone 1 or 2.
The RHE12 is classified as temperature class T6 (55°C).

Depending on the entire remote unit used, the measuring system can also be installed in a hazardous area. (Please consult the following tables).

Type of Unit	Place of Installation:	Group/ Category	Protection Class
Sensor RHM	Hazardous area, Zone 0, 1 or 2	II 1 G	Ex ia IIC
Remote Unit RHE12	Hazardous area, Zone 1 or 2	II 2 (1) G	Ex d [ia] IIB+H ₂

Haz. Area Group II	Zone (CENELEC) EN 60079-14	Category as per 94/9/CE guideline
Gas, mist or vapour	Zone 0	1 G
Gas, mist or vapour	Zone 1	2 G
Gas, mist or vapour	Zone 2	3 G

Markings:

The following Markings comprise two sections:

1. The **specific markings** show which inflammable surroundings and hazardous areas the instrument is suited for depending on the protection class taken. The identification number for the relevant certifying authority is also stated here.
2. The **additional markings** contain vital information for the safe use of the instrument. These markings are in compliance with European standard EN 60079-0 governing the operation of electrical products in potentially explosive surroundings.

1. Specific marking:

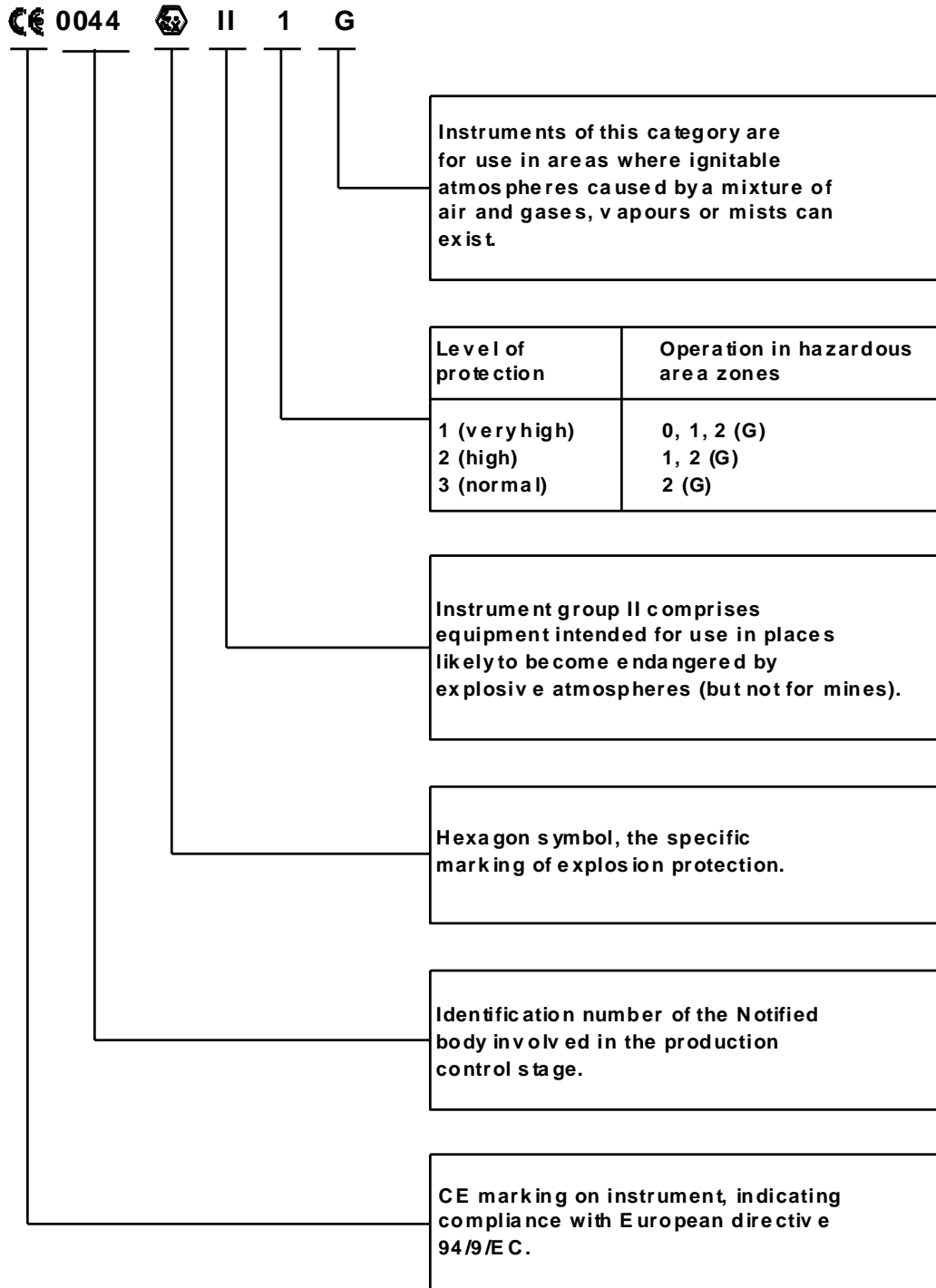

Note:

If the number, indicating the level of protection is put into brackets, the instrument can be installed in safe area only, but can be connected to the indicated category instruments in the hazardous area!

3. Additional marking:

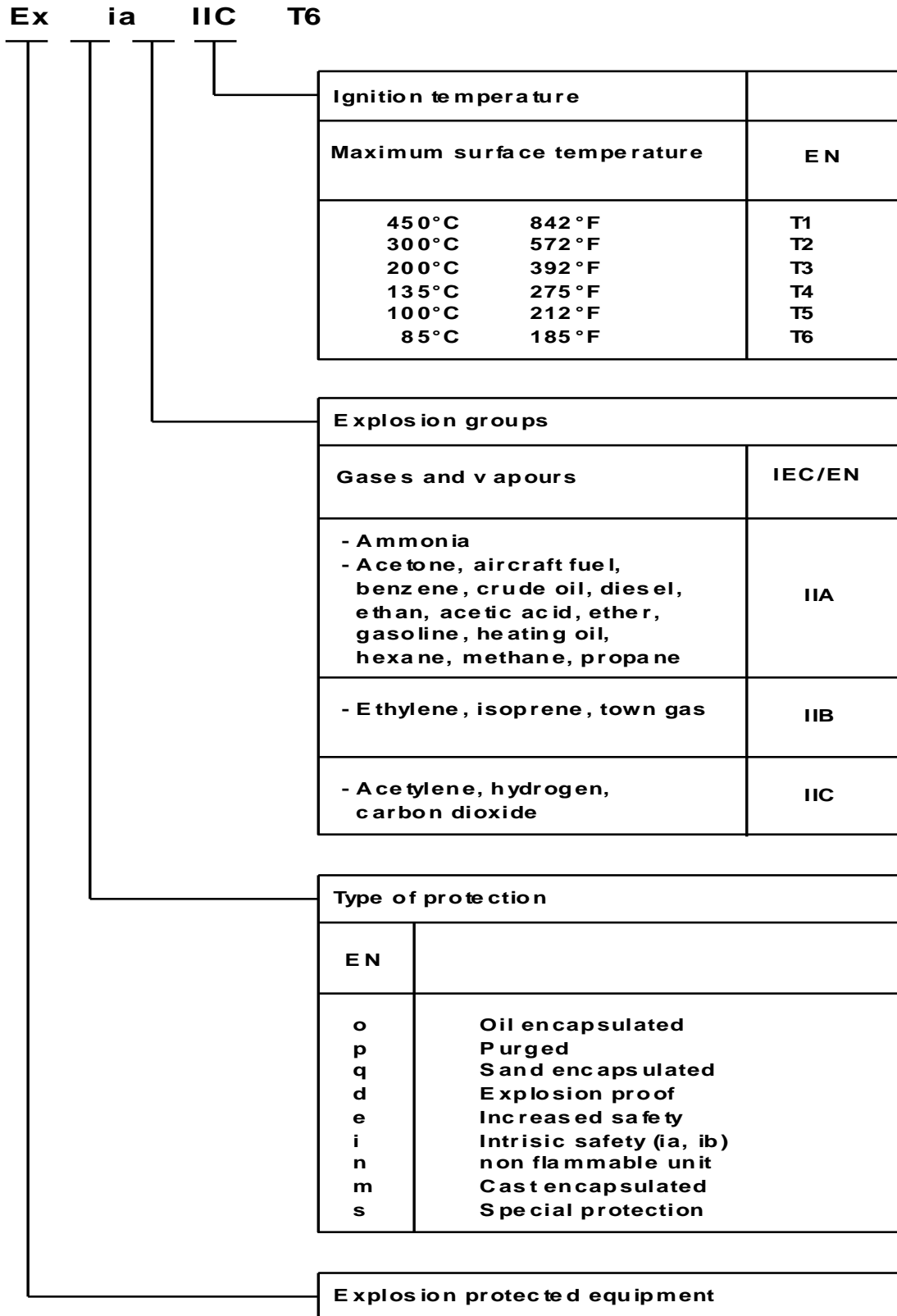

Electrical characteristics:**Intrinsically safe sensor RHM circuits, when connected to RHE:**

Circuit name	Terminals	Uo [V]	Io [mA]	Lo [mH]	Co [μ F]	Po [mW]
Drive coil	1 - 2	9,3	141	1,6	4,1	335
PT100 sense	3 - 4	7,4	29	35	10	54
PT100 current	3 - 5	7,4	29	35	10	54
Sense coil 1	6 - 7	7,4	29	35	10	54
Sense coil 2	8 - 9	7,4	29	35	10	54

Power supply circuit, remote unit RHE (galvanic isolated):

Remote unit type	Rated voltage	Rated frequency	Maximum voltage (Um)	Rated power
RHE 12	24 VDC	DC	30 VDC	7 VA

Temperature tables:**Measurement fluid temperatures (at ambient temperature 55°C):****Max. Fluid temperature [°C] in temperature class**

at T _a = 60°C	T6	T5	T4	T3	T2	T1
Sensor RHM NT	50	65	100	120	-	-
Sensor RHM ET	50	65	100	165	210	-
Sensor RHM HT	50	65	100	165	260	350

Min. fluid temperature [°C] in temperature class

at T _a = 60°C	T6	T5	T4	T3	T2	T1
Sensor RHM NT	-20	-20	-20	-20	-20	-20
Sensor RHM ET	-45	-45	-45	-45	-45	-45
Sensor RHM HT	-20	-20	-20	-20	-20	-20



With the temperatures given, and for a certain temperature class the sensor RHM components will not be subjected to any non-permissible temperatures.

RHE 12 ambient temperature T_a:

Remote unit type RHE12	Min. T _a [°C]	Max. T _a [°C]	Temperature class
According ATEX	-20	+55	T6
According CSA	-40	+55	T6

	RHEONIK	DECLARATION OF CONFORMITY
We,	RHEONIK Messgeräte GmbH Rudolf Diesel Str. 5, 85235 Odelzhausen, Germany	
declare under our sole responsibility that the	Coriolis Mass Flow Meter	
consisting of	RHM mass flow sensor & RHE remote transmitter controller	
to which this declaration relates, is in conformity with the following standards:	<ul style="list-style-type: none"> <li data-bbox="448 869 1161 900">• DIN EN 61326-1: 2006, Class A, Table 2, Industrial Locations <li data-bbox="448 931 1142 1048">• RHE12: Certificate CESI 04 ATEX 058, II 2(1) G - Ex d [ia] IIB+H₂ T6 EN 60079-0 :2006, EN 60079-1 :2007, EN 60079-11 :2007, EN 60079-26 :2007 <li data-bbox="448 1084 1166 1173">• Massflow meter Series RHM: Certificate CESI 02 ATEX 053 X, II 1 G - EEx ia IIC T6+T1 EN 50014 :1997 A1..A2, EN 50020 :2002, EN 50284 :1999 <li data-bbox="448 1209 639 1265">• AD2000-A4 DIN 3840 	
following the provisions of the Electromagnetic Compatibility Directive 2004/108/EC (EMC), the ATEX Directive 94/9/EC and the Pressure Equipment Directive 97/23/EC (PED).		
The Massflow meter Series RHM were initially assessed for compliance with the Essential Health and Safety Requirements of the ATEX Directive using the then harmonized EN 50014 series standards. An internal technical review has determined that this status was not changed by the harmonization of the EN 60079 series standards.		
Odelzhausen – Feb 10th, 2011	 Dr. Dirk Lange	

The above shown declaration of conformity (DOC) represents the latest version of the DOC at the time of release of this manual. If you need to make sure it the most current version, please contact your local GE representative.



ANNEX D

Using the HART[®] Communicator SENSCOM Program

RHEONIK the Coriolis Flowmeter experts



RHEONIK

Part of GE's Measurement
& Control business

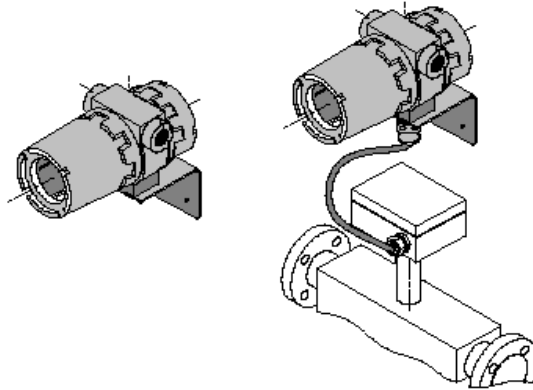

SensCom

Using the HART[®] COMMUNICATOR Installation- and Instruction-Manual

HART[®] is a registered trademark of Rosemount Inc.

RHEONIK the Coriolis Flowmeter experts

REV. 1.2 March 2012

GE Measurement & Control reserves the right to make changes without notice at any time

TABLE OF CONTENTS

Page

1. Program Installation	3
2. Hardware connection	6
3. Program Start	7

1 Programm-Installation

Auf Click the SensCom2-Setup-File-Symbol:



The following Message-Display will be displayed:

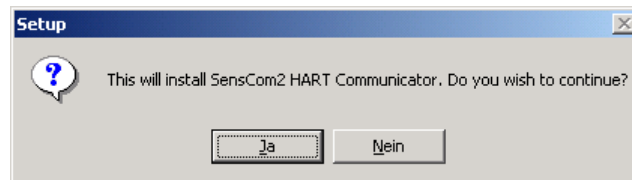

Please quit all other applications prior continuing the installation:

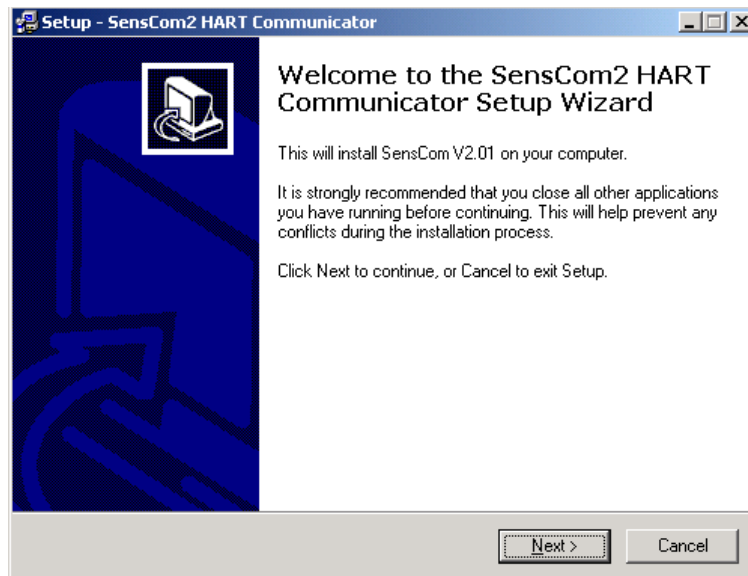

Read carefully the licence agreement and click the next button upon confirmation:

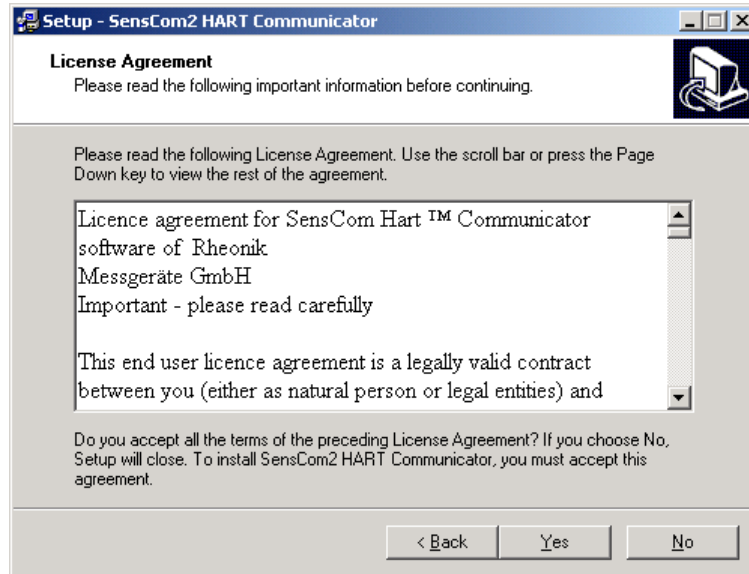

Choose your own installation folder or select the default one:

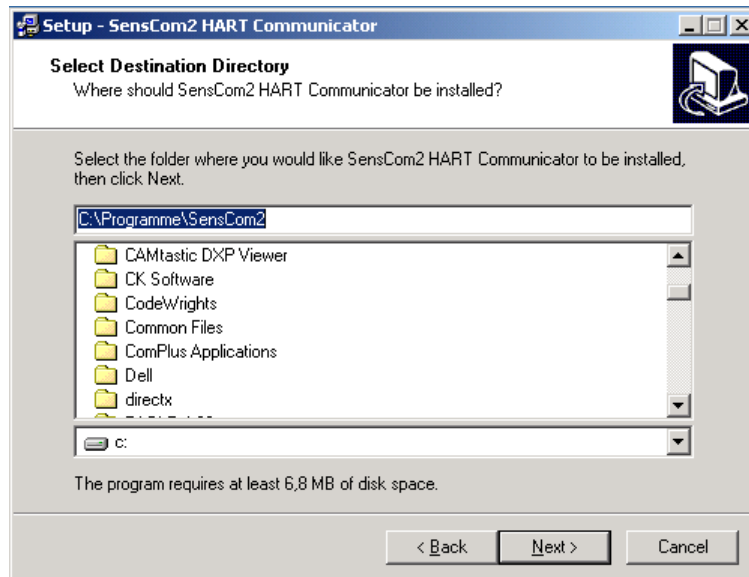

Choose the creation of an additional desktop icon:

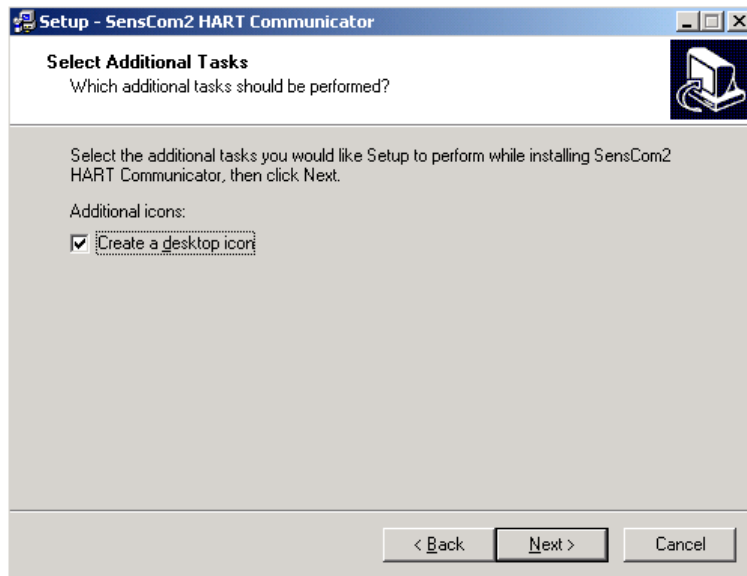

Quit the installation and start the application:

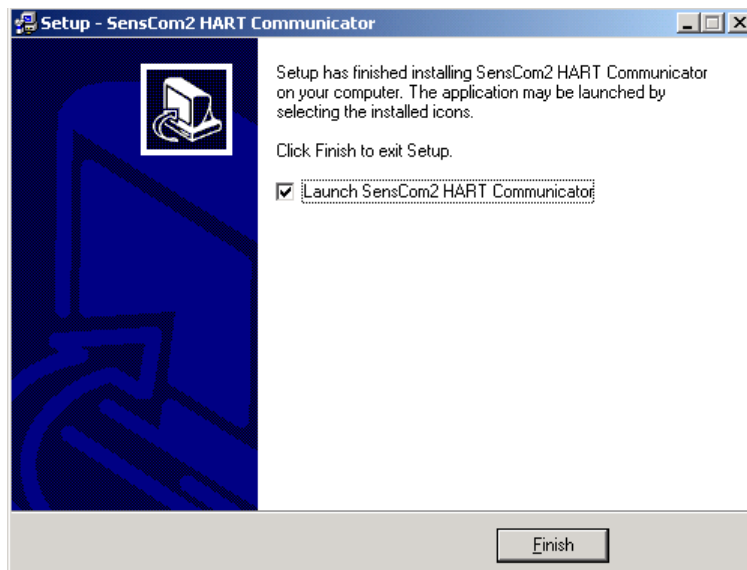

2 Hardware connection:

The field device must be connected to the RS232-Computer-Interface, using an appropriate FSK-modem.

Appropriate Modems are available from SMAR Inc. (modem type: HT311 RS323 Interface) or from MACTEC Inc. (modem type VIATOR RS232 HART Interface) or from Metran (Metran-681 HART-Modem). With short distances to the field-device (same table) a resistor of minimum 270 Ohm can be directly connected to the analog Output terminals. This resistor can be used as a hook up for the modem test terminals. The modem 9-wire SUB-D-connector must be connected to the free PC COM Port

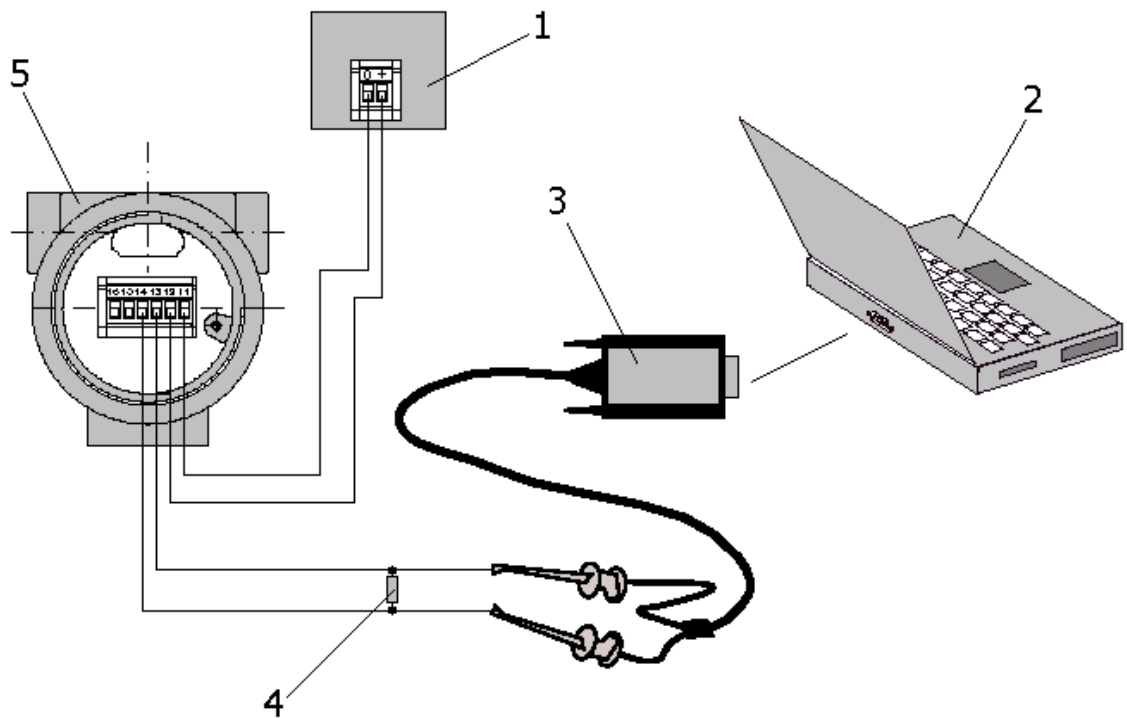

- 1: DC-Power Supply, 24V, 10 Watt
- 2: PC/Notebook
- 3: HART®-Modem
- 4: Loop-resistor (270 Ohm)
- 5: Transmitter

3 Program Start:

The program can be started by clicking the Start button in the folder Start → Programs → SensCom2 HART® Communicator. After start the following window will be opening:

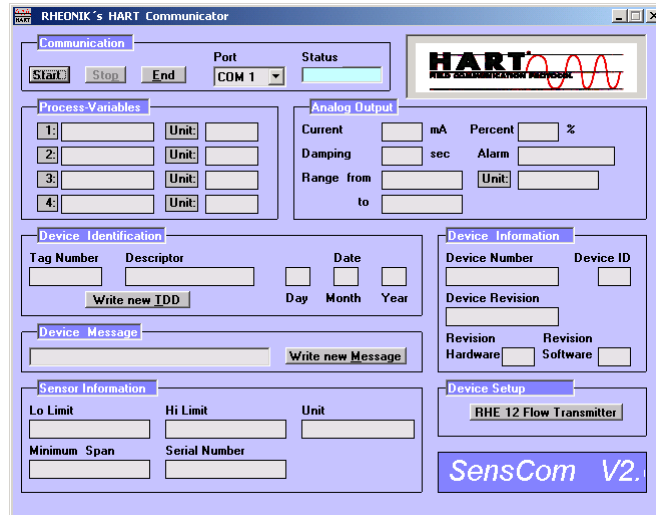

In order to establish a connection to the field device the right COM-Port must be selected. A click onto the arrow down in the Port list field will indicate all built in computer COM-ports. Choose the right one. If it is not clear which one, it is possible to test all ports one by each other in order to find out which can establish any communication to the field device. In case of no communication there will be a message window indicating a communication error.

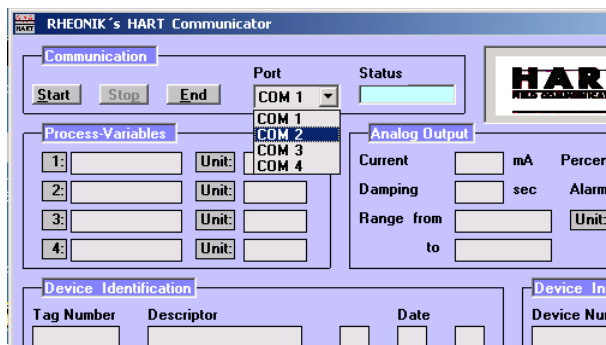

The communication can be started with a click onto the button Start. Afterwards all the data fields within the window will be cyclically refreshed, showing the information from the field device. There is also a text window for the communication status (f. e. running etc.).

The cyclic reading can be aborted by clicking the Stop button. This is necessary if those text fields like Tag-number, Descriptor, Date and Write new Message shall be rewritten with new values which should be transferred to the field device. The data transfer will be activated by pressing the button Write TDD or Write new Message.

The button RHE12 Flow Transmitter will open a new window named RHE12 – Smart Transmitter Set up, where all device parameters can be programmed. Before they can be new adjusted the existing parameter set must be read from the field device.

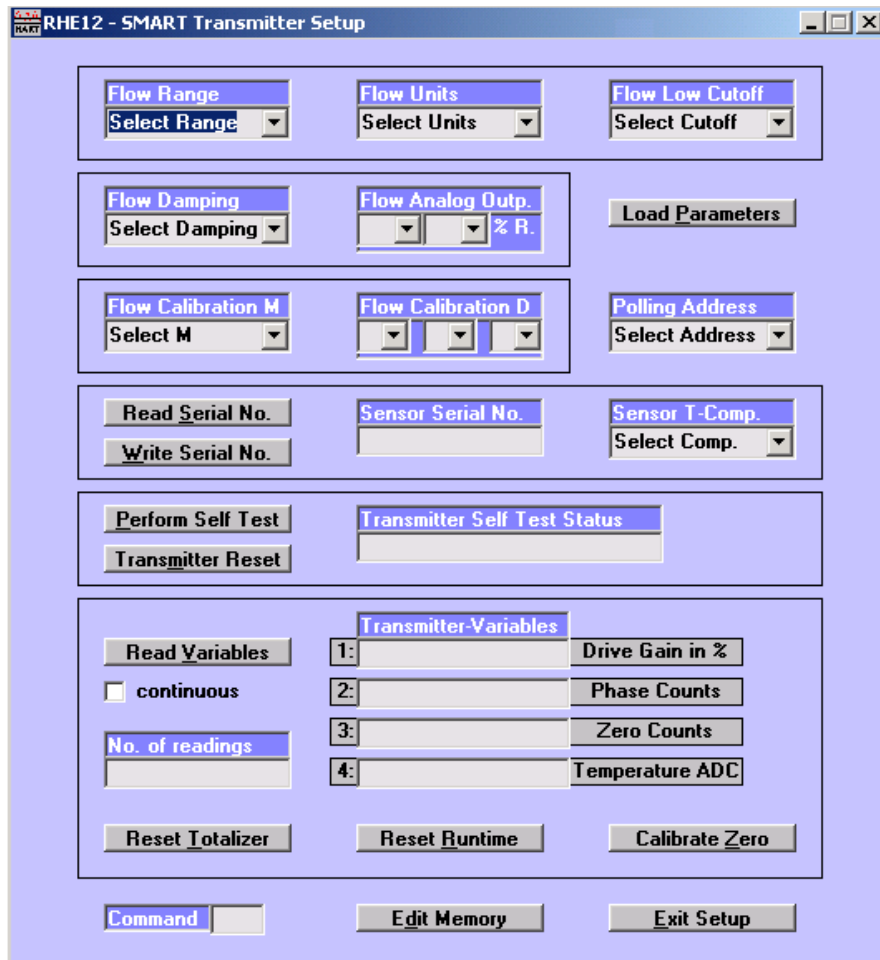

This can be done with the button Load Parameter. After clicking this button all information from the field device will be sent to the Set up program window showing the actual field device settings.

New settings can be selected using the drop-down-list fields within the window. After choosing one of the list items the new setting will be automatically transferred to the field device.

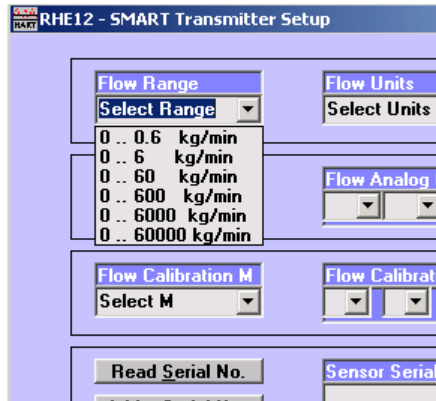

Some buttons within the window f. e. Reset Totalizer or Calibrate Zero, just to mention some, will activate the transmission of special HART commands to the field device. All actions which will be performed after reception of the command by the field device are self explaining and can be seen from the button name.