



Installation & Maintenance Instructions

Universal IV™ CM Model

2-Wire, 4-20 mA, Water Cut Monitor
with HART® Protocol

DREXELBROOK®

A Leader In Level Measurement Solutions

AMETEK®

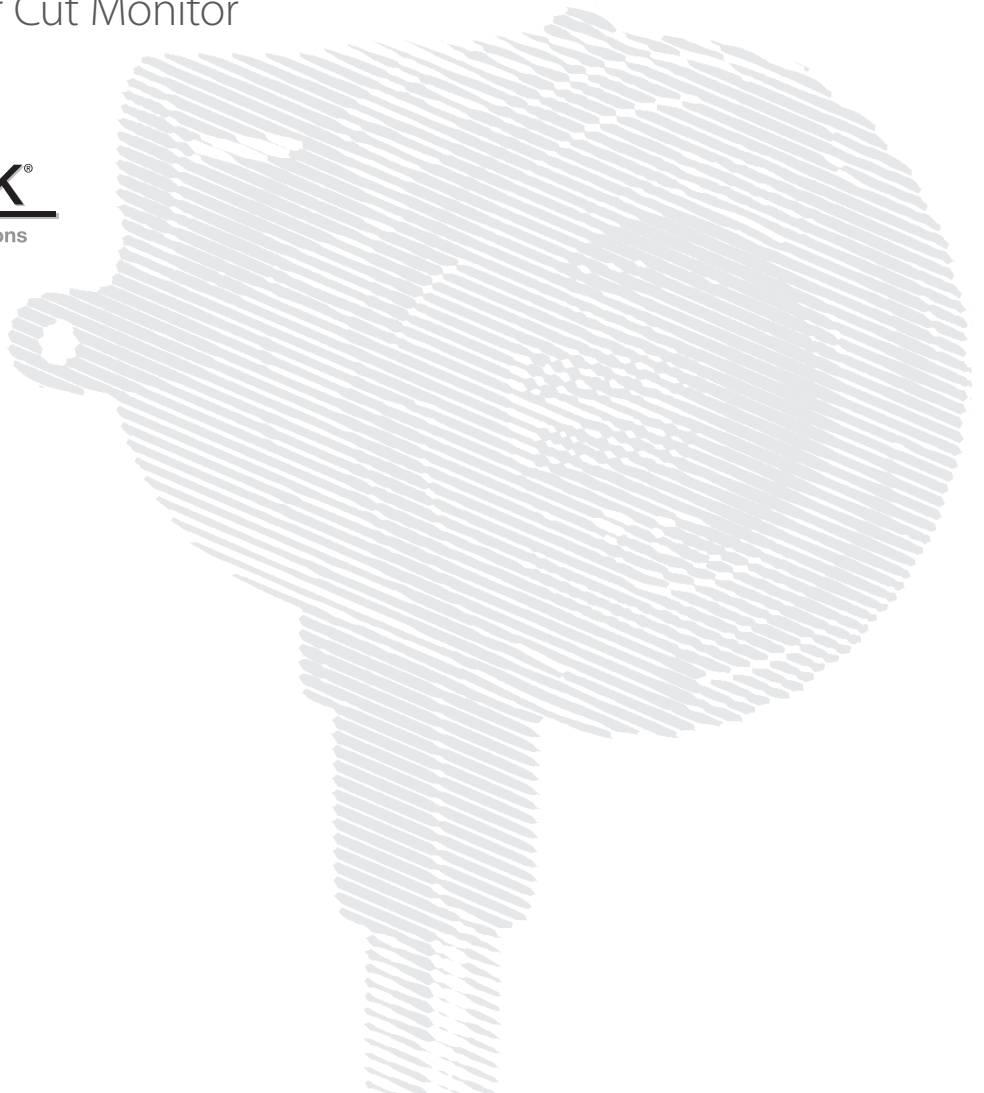

Reading Office

Cutbush Park, Danehill, Lower Earley,
Reading, Berkshire. RG6 4UT. UK.
Tel: +44 (0)118 9311188
Email: info@able.co.uk

Aberdeen Office

Unit 6 Airside Business Park, Kirkhill Industrial Estate,
Dyce, Aberdeen. AB21 0GT. UK.
Tel: +44 (0)1224 725999
Email: ab@able.co.uk

Internet: www.able.co.uk
e-procurement: www.247able.com
Registered in England No: 01851002
VAT No: GB 417 2481 61



Contents

Section 1: Introduction.....	1
1.1 System Description	1
1.2 Unpacking.....	1
1.3 Model Numbering	2
Section 2: Installation	5
2.1 Installation Guide.....	5
2.2 Installation Considerations	7
2.3 Sensing Element Insertion and Active Lengths	8
2.4 Mounting the Electronic Unit	9
2.5 Wiring the Electronic Unit.....	12
2.6 Wiring the Sensing Element.....	13
2.7 Surge Voltage (Lightning) Protection	15
2.8 RFI (Radio Frequency Interference) Filters	15
Section 3: Configuration and Calibration with Drexelbrook Software, HRTWin.....	17
3.1 Installing The USB Modem.....	17
3.2 Install the Windows Version HRTWin Software	18
3.3 Description of Function Keys.....	20
3.4 Configuration	21
3.5 Calibration	22
3.6 Set D/A Trim	26
3.7 Save/Print Entries.....	27
3.8 Calibration & Configuration via Display/Keypad	28
Section 4: Specifications	31
4.1 Transmitter Specifications.....	31
Section 5: Normal Maintenance	33
5.1 Viewport Cleaning	33
Section 6: Hazardous Location Approval Supplementary Instructions	35
6.1 General safety information	35
6.2 The Compartment Cover.....	36
6.3 Standards and Approvals	37
Section 7: Control Drawings.....	39
7.1 ATEC / IECEX	39
7.2 FM US / FMC	47
Section 8: Approval Certificates	63
8.1 FM US Approval Certificate.....	63
8.2 FM Canada Approval Certificate	69
8.3 IECEX Approval Certificate.....	74
8.4 ATEX Approval Certificate	78
8.5 CE Mark Declaration of Conformity.....	83

Section 1

Section 1: Introduction

1.1 System Description

The instructions in this manual are for the AMETEK Drexelbrook Universal IV CM Model Water Cut Monitor for measurement of the percentage of water in oil. Each AMETEK Drexelbrook Universal IV CM system consists of a two-wire, 4-20 mA electronic unit and a 700 series sensing element. Communication with the device is done by either an onboard keypad or with a laptop via HART® protocol.

AMETEK Drexelbrook has been measuring water cut with capacitive technology for over 40 years. Using capacitance to measure water cut is widely successful because of the large difference between the dielectric constants of oil ($k \approx 2.3$) and water ($k \approx 80$). The sensing element and the pipe wall form the necessary two plates of the concentric capacitor. The system electronics transmit a radio frequency voltage to the sensing element that measures changes in capacitance. As the amount of water in the flowing oil increases, the net dielectric of the fluid increases which causes the capacitance to increase. The onboard electronics can then compute the relationship between capacitance change and water cut. It is termed a two-wire transmitter because the same two wires that are used to power the unit also indicate the change in Cut (4-20 mA).

1.2 Unpacking

Carefully remove the contents of the carton and check each item against the packing list before destroying any packing material. If there is any shortage or damage, report it immediately to the factory.

1.3 Model Numbering

System Electronics and Probe Model



1.3 Model Numbering (Continued)

Dimensions and Process Connection

Process gland wetted part (X)

B 316/316L SS

Process connection (XX)

A0 3/4" NPT
B0 1" NPT
BA 1" 150# RF Carbon Steel
BB 1" 150# RF 316/316L Stainless Steel
CB 1" 300# RF 316/316L Stainless Steel
BD 1" 150# RF 316/316L SS TFE
C2 1 1/2" Tri-Clamp
E2 2" Tri-Clamp
FA 2" 150# RF Carbon Steel
FB 2" 150# RF 316/316L Stainless Steel
GB 2" 300# RF 316/316L Stainless Steel
FC 2" 150# RF CS TFE Face
FD 2" 150# RF 316/316L SS TFE
FE 2" 150# RF CS Inserted TFE
FH 2" 150# RF 316L SS Seal-Tyte
G0 1/2" NPT
IA 3" 150# RF Carbon Steel
IB 3" 150# RF 316/316L Stainless Steel
J2 3" Tri-Clamp
JB 3" 300# RF 316/316L Stainless Steel
KB 4" 150# RF 316/316L SS
KC 4" 150# RF CS TFE Face
KD 4" 150# RF 316/316L SS TFE
KG 4" 150# RF CS Seal-Tyte
LA 4" 300# RF Carbon Steel
LB 4" 300# RF 316/316L Stainless Steel
WB 6" 600# RF 316/316L Stainless Steel
2B 8" 600# RF 316/316L Stainless Steel
XX* Many more options available upon request (ANSI, DIN, JIS)

Insertion Length in MM

XXXXXX Length of the probe in millimeters from process connection to the bottom of the probe. Ranges from 13.875" to 39.275" (352.425mm to 997.585mm) I.L. depending on pipe size and sensing element - Refer to pipe size look up table

Cote-Shield™ Length in MM

XXXXXX Length of the Cote-Shield in millimeters. Typical 3.5", 6" or 10" (88.9mm, 152.4mm, 254 mm) depending on pipe size and sensing element- Refer to pipe size look up table

Inactive Length in MM

XXXXXX Length of the inactive part of the probe that is not measured.
This option does not apply to Cut Monitors

Inactive Material

N Not Applicable to Cut Monitors



Section 2

Section 2: Installation

2.1 Installation Guide

Use the following mounting and installation instructions so that the sensing element will operate properly and accurately:

- The sensing element should be mounted in a section of pipe as close to the center and as parallel to the pipe as possible. Factory calibration assumes mounting on the pipe centerline and in the correct size pipe.
- Vertical mounting, with the tip down, is preferred, but not essential.
- Gas bubbles must be excluded from the active area by maintaining pressure and, if necessary, a degasser upstream from the sensing element. Gas bubbles (whether from natural gas, air or steam) decrease the accuracy of the measurement.
- Do not take the sensing element apart or loosen the packing glands.
- In large pipe installations (greater than eight inches), the length of the cote shield section must be long enough (i.e. length of nozzle short enough) that the cutout in the concentric tube is in the actual flow of oil.
- For large pipes with no bends (18 inch and larger), it is possible to mount the sensing element at a 45 degree angle to provide sufficient flow through the shield of the sensing element.

2.1 Installation Guide (Continued)

Installation in a Pipe 8 inches or larger

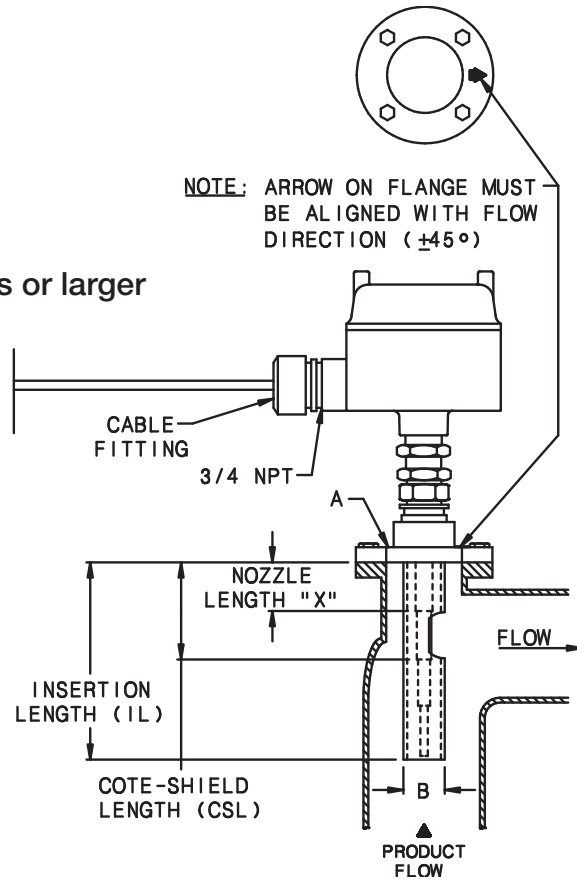

Installation in a Pipe 18 inches or larger

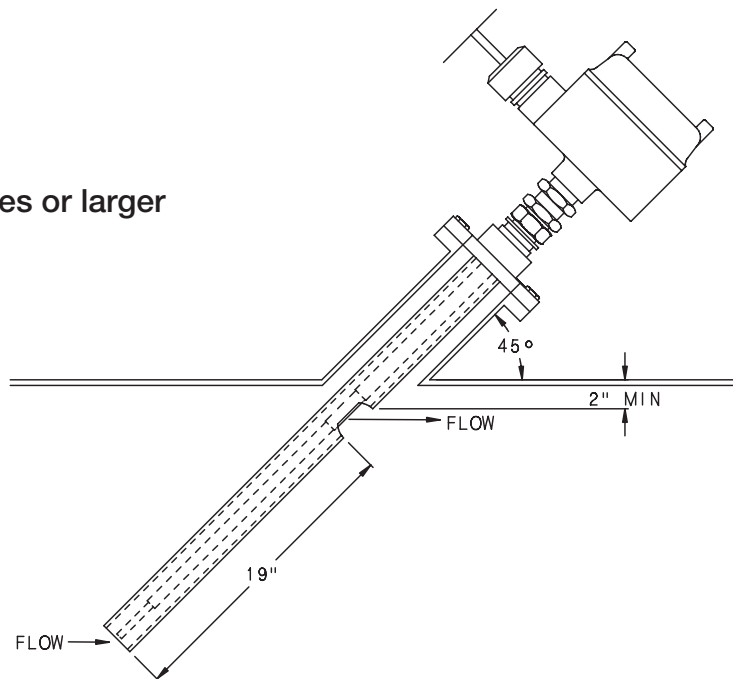

2.2 Installation Considerations

The sensing element must be mounted at an existing or created, 90 degree bend in the pipe. It can be installed through a tee or a weld-o-let to a 90 degree elbow. The vertically downward mounting attitude is preferred for ease of inspection or cleaning, since draining of the pipe is not required. Regardless, the probe will function in any attitude, as long as the pipe is completely full in the active probe area. **See the figure below** for ideal installation orientation.

The probe is active from its tip to the end of the Cote-Shield element. In the area of the Cote-Shield, it is completely inactive.

In all cases, the presence of gas bubbles, whether from air, petroleum vapor, steam, or natural gas, will reduce accuracy, producing lower readings. One of the most common causes of gas bubbles is abrupt pressure drops in high temperature streams, which can allow water and light ends to flash.

An in-line mixer just upstream of the Cut Monitor is highly recommended for streams which go above 10% water cut. Accuracy is based on uniform, oil-continuous emulsion, so any unplanned separation will cause errors.

All instruments are factory calibrated. If calibration trimming is required, it may be done through the Keypad or with AMETEK Drexelbrook PC software. The proprietary software allows one shot calibration trimming with one reading and sample. The Real-time View window is useful for observing transmitter function and troubleshooting.

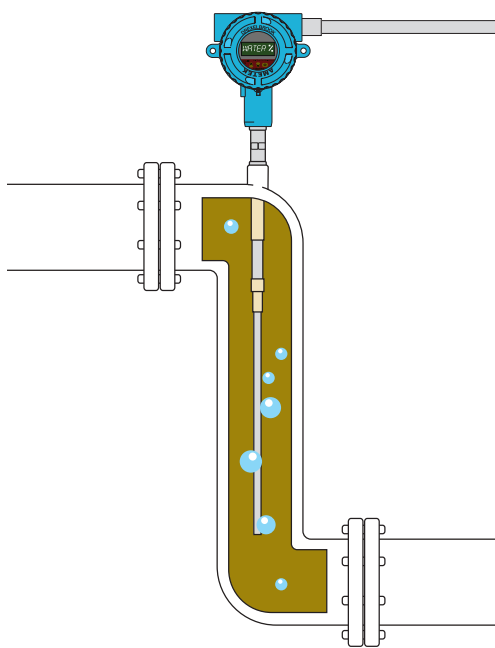

Suggested Installation

2.3 Sensing Element Insertion and Active Lengths

The Cut Monitor sensing element varies with pipe size. The larger the pipe diameter size, the longer the sensing element active length must be. The Cote-Shield length is sized so the sensing element is fully extended into the fluid beyond nozzles and elbows. Below are some standard sensor dimensions.

700-1202-0XX Series Sensing Elements		
Pipe Size	Cote-Shield Length	Insertion Length
1"	3.5"	13.875"
1"	6"	16.375"
1"	10"	20.375"
2"	3.5"	21.25"
2"	6"	23.75"
2"	10"	27.75"
3"	3.5"	25.5"
3"	6"	28"
3"	10"	32"
4"	6"	31.125"
4"	10"	35.125"
6"	6"	35.375"
6"	10"	39.375"
8" and >	10"	25.5"
In Tank	3.5"	19"
In Tank	6"	21.5"
In Tank	10"	25.5"

For Sensors that can meet NACE Requirements			
Pipe Size	Cote-Shield Length	Insertion Length	Model Number
1"	4"	18.7"	700-0201-051
2"	6"	28.1"	700-0201-052
3"	10"	2.9"	700-0202-053
4"	10"	32.1"	700-0202-054
6"	12"	38.4"	700-0202-056
8" and >	18"	37"	700-0201-058
In Tank	8"	27"	700-0201-059

Sensing Element Dimensions

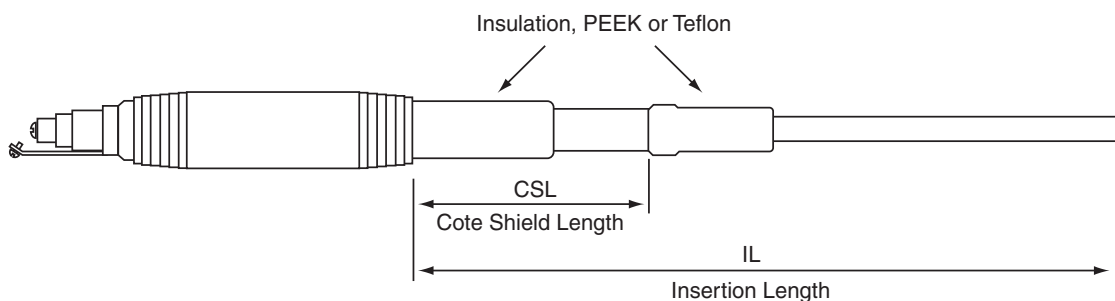

2.4 Mounting the Electronic Unit

The integral electronic unit is mounted with the sensing element. The remote electronic unit is designed for field mounting, but it should be mounted in a location as free as possible from vibration, corrosive atmospheres, and any possibility of mechanical damage. For convenience at start-up, mount the instrument in a reasonably accessible location. Ambient temperatures should be between -40°F and 167°F (-40°C and 75°C).



When installing conduit to the electronic unit, be sure that vertical conduit runs will not cause water to enter the electronic unit housing, as shown in Figure Below.

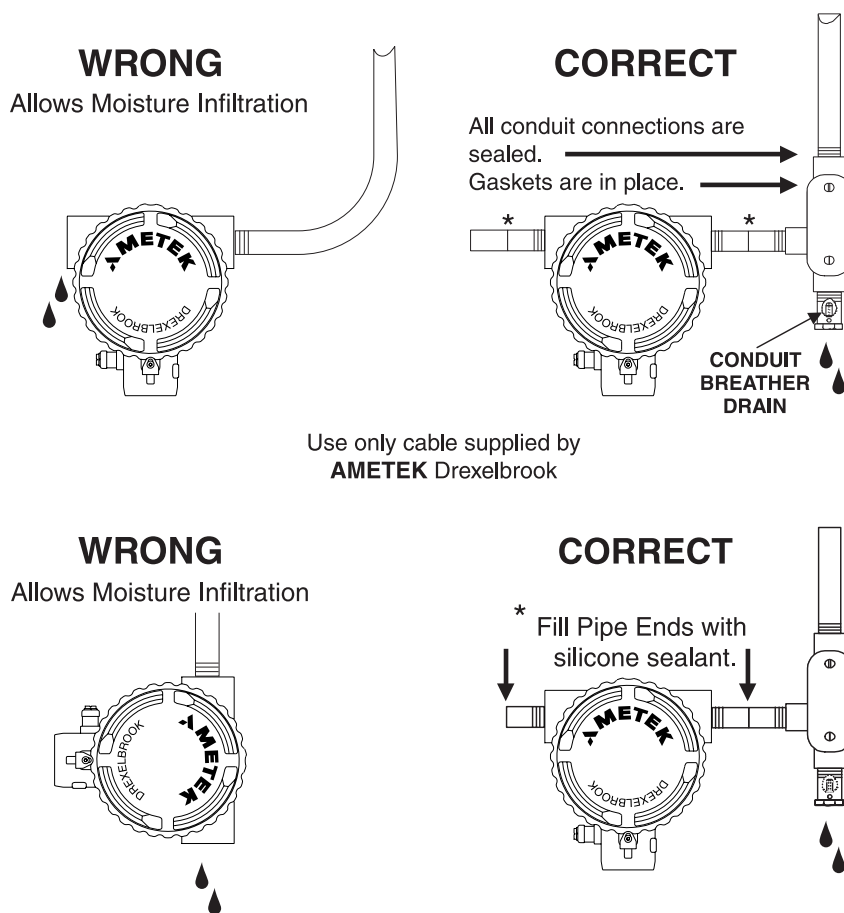

Use only cable supplied by
AMETEK Drexelbrook

Figure 2-1
Recommended Conduit Installation

2.4 Mounting the Electronic Unit (Continued)

Integral System Mounting

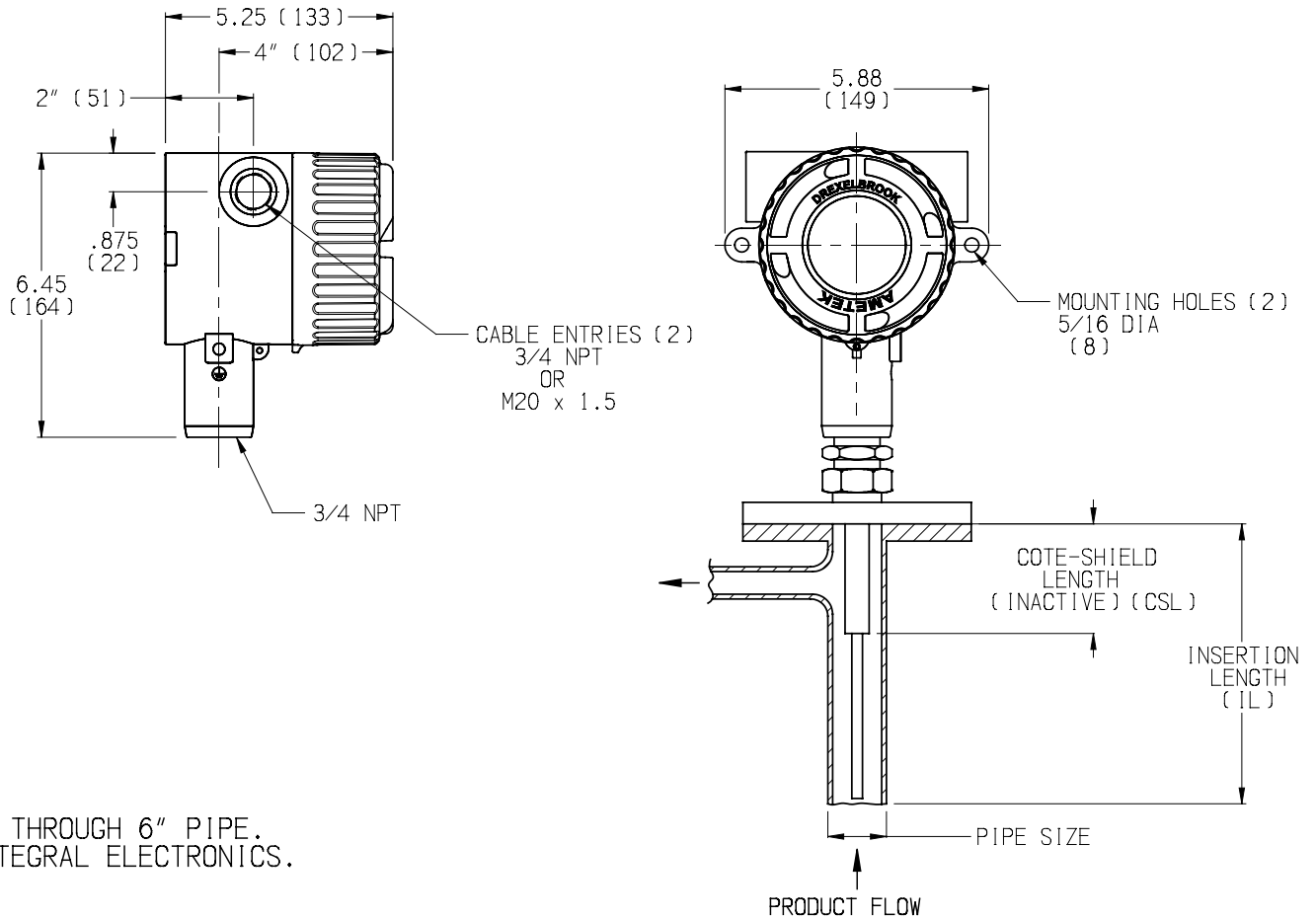

NOTES:

1. 1" THROUGH 6" PIPE.
2. INTEGRAL ELECTRONICS.

Figure 2-2
Integral Mounting Dimensions

2.4 Mounting the Electronic Unit (Continued)

Remote System Mounting

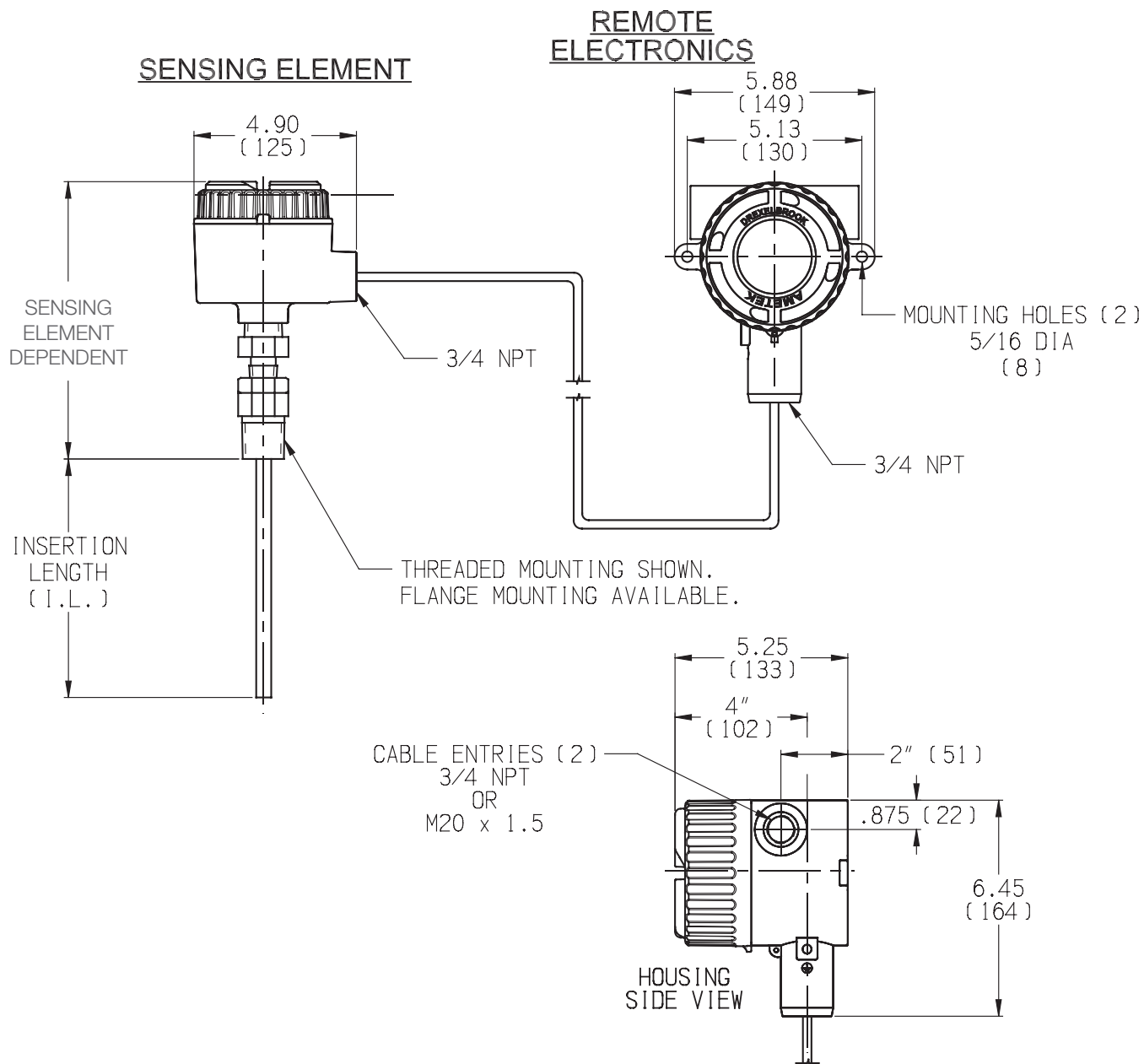

DIMENSIONS ARE IN INCHES
(mm)

Figure 2-3
Remote Mounting Dimensions

2.5 Wiring the Electronic Unit

The signal connections are made to the three-terminal block on the front of the chassis. Due to the low power consumption of the instrument, the wiring need only be light gauge (e.g. 20 AWG). Shielded twisted pair cables are recommended.

Integral units are pre-wired to the sensing element at the factory. **Figure 2-5** shows the wiring of the integral unit.

See **Figure 2-6** for wiring connections of the remote unit. The cable from the sensing element is connected to the terminal strip below the instrument chassis. The cable connections are sensing element (prb) or center wire (cw), ground (gnd), and shield (shd).



CAUTION!

Before using Intrinsic Safety Barriers, read manufacturer's instruction for barrier operation.



The Universal IV has a built-in current limiter which holds the signal current to a maximum of 28 mA.

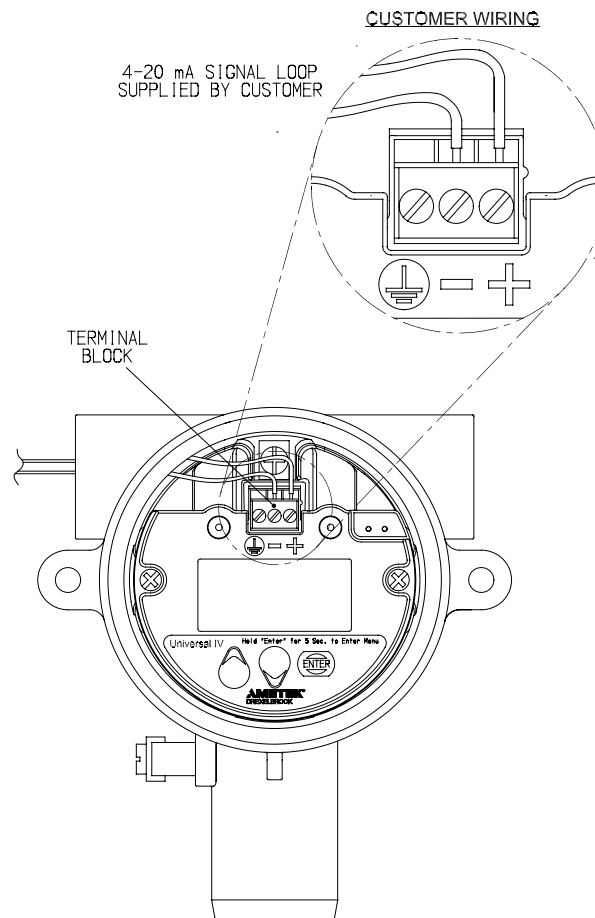

Figure 2-4
Universal IV Wiring Connections

2.6 Wiring the Sensing Element

The cable connections to the remote sensing element are shown in **Figure 2-6**

- Do not connect the cable to the sensing element until after the sensing element has been installed in the vessel and the conduit / housing has been secured.

Only cables supplied by Drexelbrook should be used to connect the transmitter to the sensing element. Use of other cables can result in unstable performance.

Integral System Sensing Element Wiring

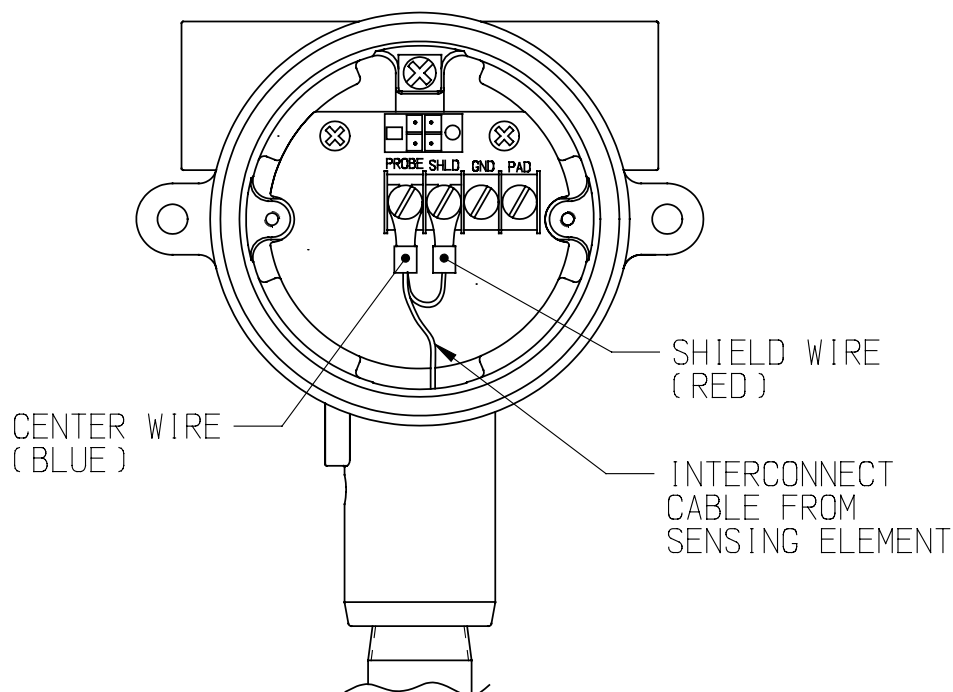

Figure 2-5
Universal IV Wiring Connections Integral Mounting

2.6 Wiring the Sensing Element (Continued)

Remote System Sensing Element Wiring

ELECTRONIC UNIT REMOVED FOR CLARITY

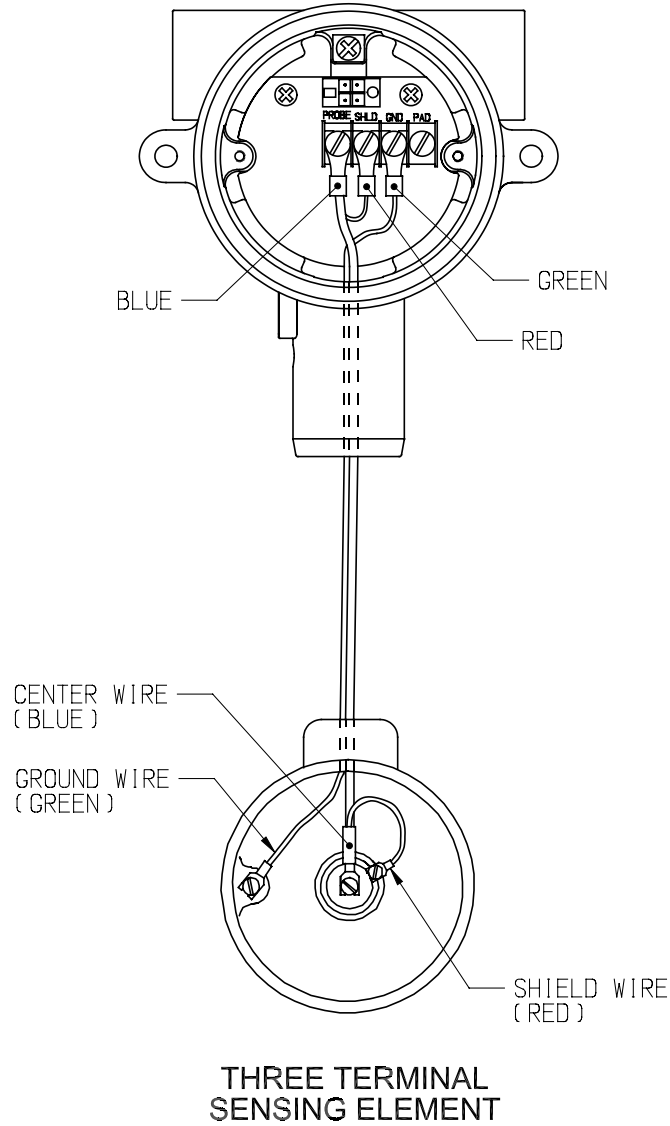

Figure 2-6
Universal IV Wiring Connections, Remote Mounting

2.7 Surge Voltage (Lightning) Protection

Optional surge protection can be supplied with transmitters that are expected to be exposed to surge voltages or surges due to lightning near the two-wire loop. A Drexelbrook Model 401-0016-028 Signal Filter Assembly affords additional protection to the transmitter but is not absolute in its protection against a very close lightning strike. **Refer to Figure 2-9** to properly connect the Signal Filter Assembly. You must insure the transmitter housing is well connected to an earth ground.

2.8 RFI (Radio Frequency Interference) Filters

When installing the Universal IV transmitter, follow these recommendations to avoid problems with Radio Frequency Interference (RFI).

- Choose a location to mount the electronic unit at least 6 feet (2m) from a walkway where personnel using walkie talkies may pass.
- If the vessel is non-metallic, select, if possible, a shielded (concentric) sensor. If unsure about suitability, contact the AMETEK Drexelbrook Applications department for a recommendation.
- For remotely-mounted electronic units connect the sensor to the electronic unit by placing the coaxial cable in grounded metal conduit. Integrally mounted electronic unit sensor connections and triaxial cables are already shielded.
- Use Shielded Twisted Pair wiring for all loop wiring. Loop wiring should also be in grounded metallic conduit.
- Ground the electronic unit and housing with a minimum of 14 gauge wire to a good earth ground. Make sure that conduits entering and leaving the housing have a good electrical ground connection to the housing

If the recommendations listed are followed, it is usually not necessary to add RFI filtering to protect against signal strengths of 10 Volts/ Meter or less. This degree of protection is usually sufficient to protect against walkie talkies that are used 3 feet (1m) or more from a typical electronic unit. If greater protection is required, or filters have already been provided, install RFI filters as shown in **Figure 2-8**.

CE Mark Certification:

Triaxial Cable - Systems with remote mounted electronics that connect to the sensing element via a triaxial cable do not need a sensing element RFI filter or metal conduit to maintain CE Mark certification.

2.8 RFI Filters (Continued)

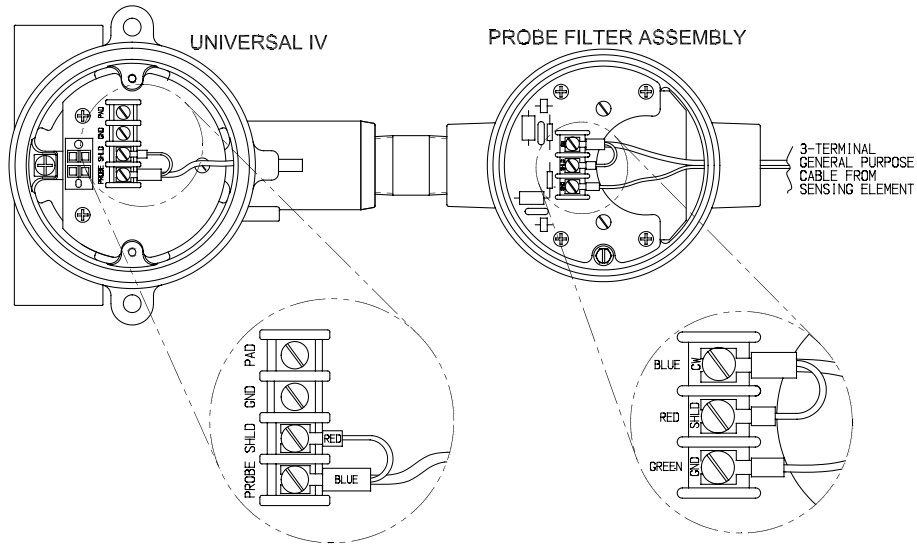

Figure 2-8
Sensing element Radio Frequency Interference (RFI) Filters
Part # 401-0016-029

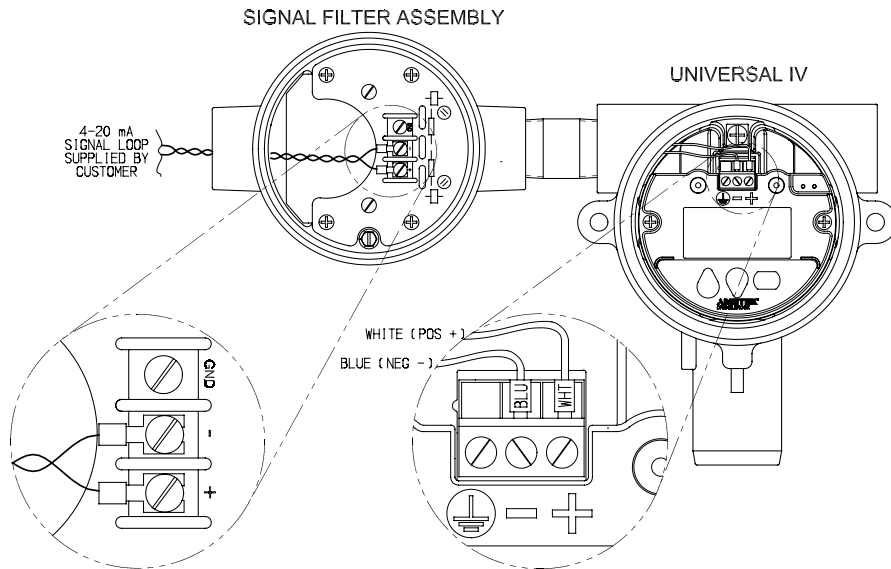

Figure 2-9
Signal Radio Frequency Interference (RFI) Filters / Surge Protection
Part # 401-0016-028

Section 3: Configuration and Calibration with Drexelbrook Software, HRTWin

This section instructs the user how to use the AMETEK Drexelbrook PC calibrator software to configure and calibrate the Universal IV (RF Admittance) Transmitter.

3.1 Installing The USB Modem

HART® Modems are available from third party vendors. Refer to directions supplied by modem manufacturer.

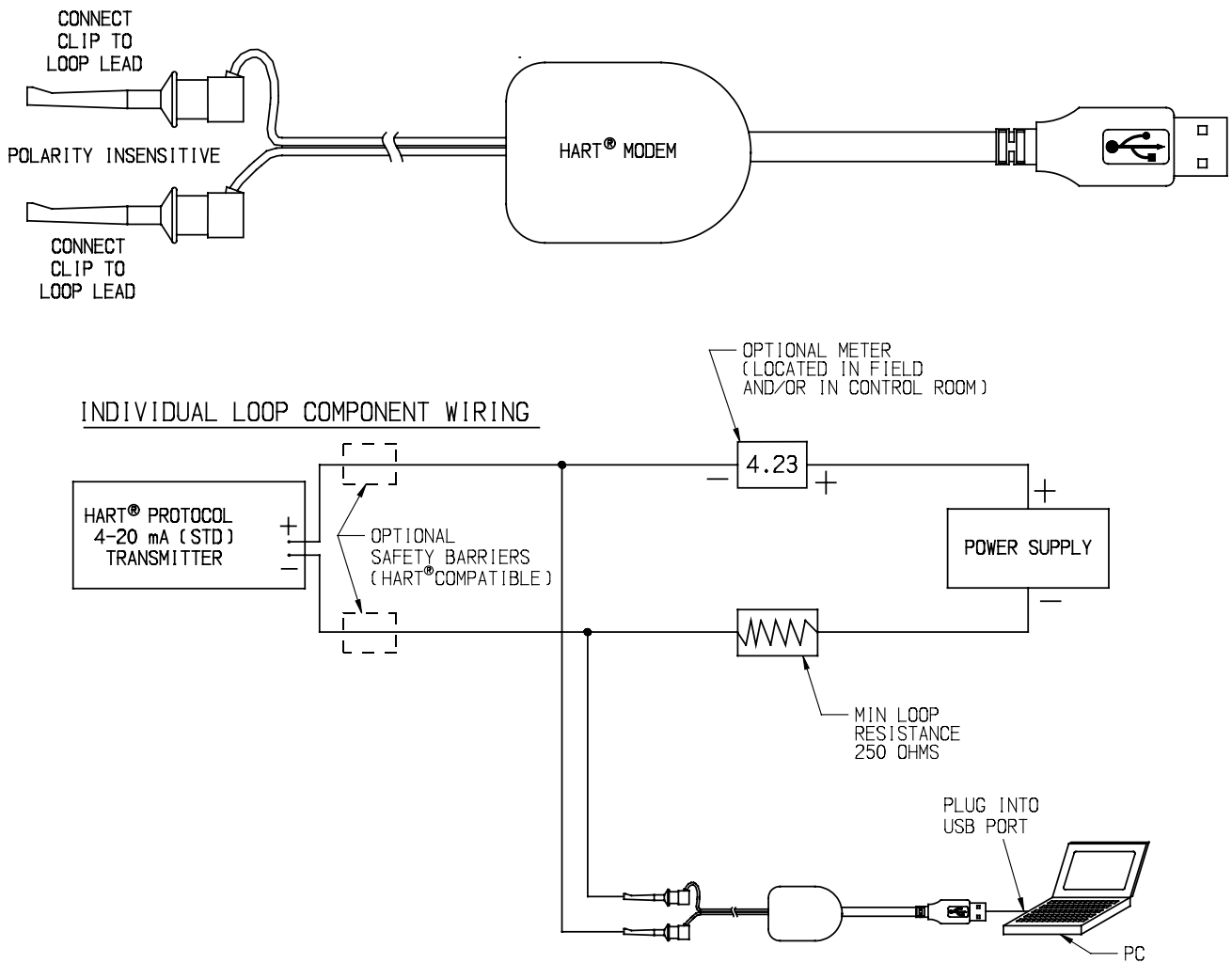

Figure 3-1
USB Modem Assembly & Loop Connection

3.2 Install the Windows Version HRTWin Software

Installation is quite simple.

- A. Download the software from www.drexelbrook.com.
- B. If program does not "Auto-Run", select the location where the file was saved and run the set-up program manually.
- C. Follow "On-Screen" instructions in Setup to create program file.
- D. Once loaded, double click "HRTWin" icon and the program will run under its own window.
- E. Select communication port [Com 1, Com 2, etc.] and then click "OK." See **Figure 3-2**.
- F. If you are not sure which communication port you are using (such as when first using a USB modem), select "Search Ports," then OK. The software automatically will seek out the correct one. In either case the software begins to communicate with the HART protocol transmitter and returns with a view (below) containing "name plate data," Tag ID and all default or existing configuration information. This is the same as if you clicked on the Read Transmitter function button.
- G. The next view, shown in **Figure 3-3**, appears automatically, displaying current transmitter database for calibration set-up for your selected Tag ID. The Scratch Pad will automatically show the last message (last user, last calibration, etc.) up to 32 characters. If this is a new transmitter, the Tag ID is user-defined. Serial number, transmitter software version, range, etc. is automatically entered from the "name plate data" embedded in the transmitter:

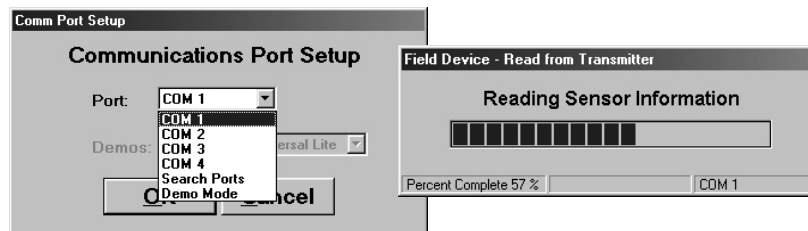

Figure 3-2
Selecting COM ports during software installation

3.2 Install the Windows Version HRTWin Software (Continued)

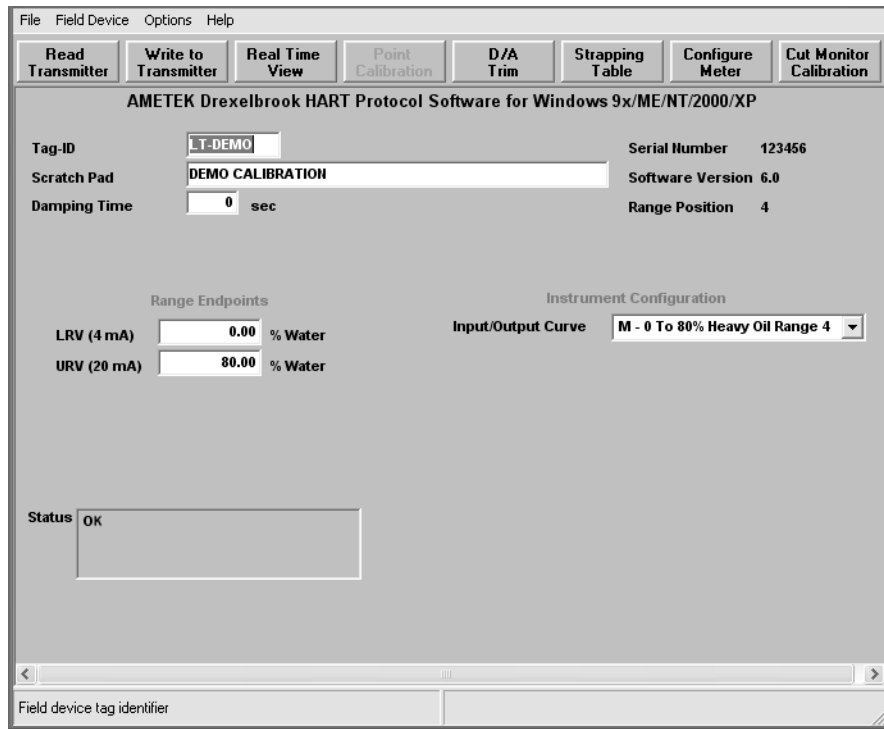

Figure 3-3

PC Software Menu Screen automatically communicates all "name plate data" from transmitter

3.3 Description of Function Keys

The following paragraphs describe the function buttons. The data fields are described in Section 3.7 Configuration.

Read Transmitter [F3 on keyboard]

Reads all pertinent data from the transmitter and displays it on the screen. The Read function also updates the real time window. Keep in mind that it takes several seconds to load the information from the transmitter. When the load is complete, the screen shows the database parameters, except any user-defined strapping table information. This command is also used when connecting to another transmitter.

Write to Transmitter [F5 on keyboard]

Sends new or edited configuration data to the transmitter. Data fields that have been edited but not sent to the transmitter are displayed in red.

Real Time View [F4 on keyboard]

Displays the real time values of water percentage, capacity, loop current, and status.

D/A Trim

Allows a field reference meter to be connected to the transmitter for adjusting transmitter output current. See Section 3.9.

Strapping Table

Displays the values of the input (pF) vs. output (% water) in a table of up to 21-points. Allows points to be adjusted when actual data deviated from the theoretical input/output curve. See Section 3.8.4

Configure Meter

Configures the Digital Integral Meter (440-44-3) used for local indication. See Section 3.10

Cut Monitor Calibration (One-Shot®)

Used to adjust calibration to specific oil and temperature that the transmitter monitors. See Section 3.8.1



HRTWin Tool Bar

3.4 Configuration

Configuration involves downloading information to the HART protocol transmitter that is specific to the application that is being measured.

- A. Begin configuration by using **Tag ID** (8 characters) to identify the unit or vessel. Use the **Scratchpad** (32 characters) to record the date of calibration or other similar notes. Press Tab or Enter on your keyboard.
- B. Edit **Damping Time** from 0-90 seconds, if desired.
- C. Click on **Write to Transmitter**.

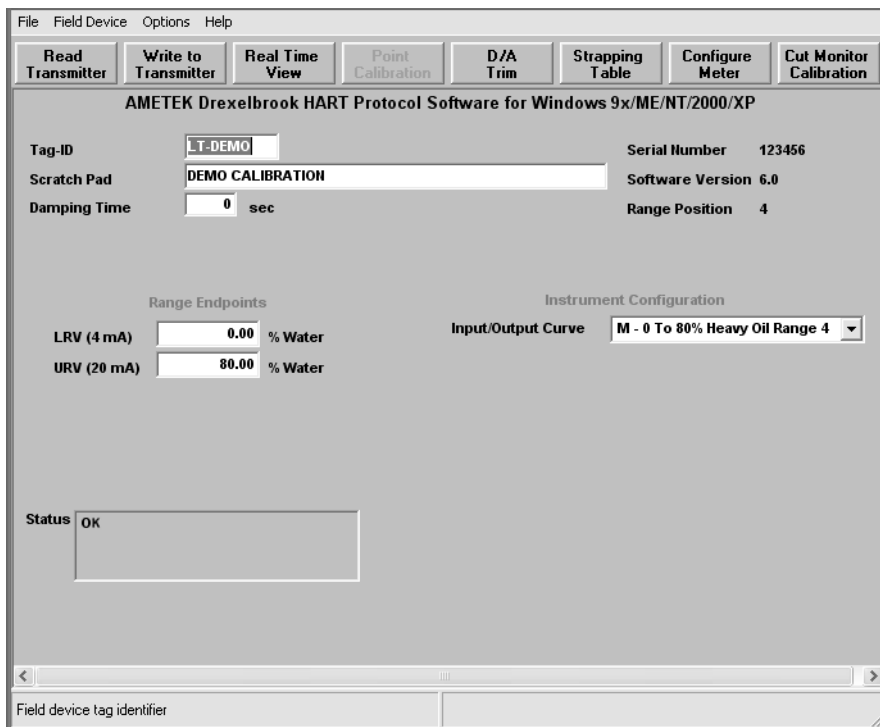

HRTWin Main Screen

3.5 Calibration

All Drexelbrook Universal IV CM Water Cut Monitor instruments are calibrated at the factory according to:

- Size of pipe, and
- Density of oil

Specific factors could cause the factory calibration to be less accurate than is required. For example,

- A. Pipe I.D. is smaller than nominal size (Sched. 80, 160, or extra heavy pipe)
- B. Sensing element is not centered (parallel to axis) in pipe. This condition causes higher (never lower) readings.
- C. Oil may be heavier (higher readings) or lighter (lower readings) than expected.
- D. Major temperature deviations.

Do not change the factory calibration without obtaining data that indicates a calibration change is necessary. If the output reading is low because of gas, steam, or air in the stream, then no amount of calibration will produce satisfactory performance. Consult the factory at 1-800-527-6297.

Once the gas is gone, an accurate calibration check can be made. The following equipment is required to check the calibration of a cut monitor application and record sample data:

- A centrifuge (or other API-approved standard) to sample water content.
- If the stream temperature is greater than 150°F (65°C), a sampling bomb with a minimum capacity of 500 ml.
- Temperature stabilization bath.

3.5.1 One Shot ® Calibration Trim Using HRTWin Software

- A. With a PC connected to the signal loop, click on the Real Time View button to open the “Real Time View” Screen.
- B. Take a sample of the fluid from as close to the probe as possible. Use a sampling bomb if the stream temperature is greater than 150°F. Stabilize at 150°F before determining water content.
- C. Read and record water percentage from the “Real Time View” as the sample is being taken.
- D. After determining the actual water percentage in the sample, close the “Real Time View” window and open the “Calibration Screen” by clicking on the Cut Monitor Calibration button.
- E. Enter the % water reading, recorded at the time of sampling in the “Indicated Water” box. Enter the result of the sample test in the “Sampled Water” box and click on the Calibrate button.
- F. Click on the Write To Transmitter button to install the revised calibration in the transmitter.
- G. Depending on the range, if the original calibration and the measured sample differed by more than 2.5% water, another iteration will probably be required. Unless there is an overwhelming discrepancy, it is best to monitor the performance with this new calibration for a few days before making a second change.

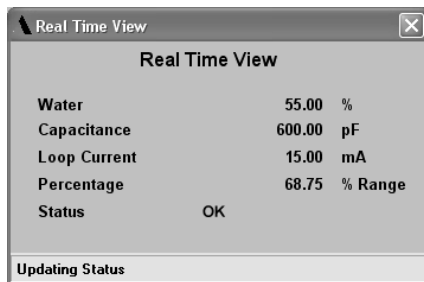

RTV Window

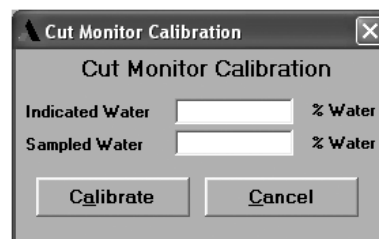

Calibration Window

3.5.2 Use of Sample Bomb

In order to get accurate sample readings on the lines running hotter than 150°F, it is necessary to prevent water from flashing off as steam. This requires a sampling “bomb” to capture the sample under pressure, followed by cooling to 150°F.

- A. Connect the sampling bomb to the sample tap
- B. Open top and bottom valves on the bomb
- C. Open the sample tap with a catch basin under the bomb
- D. Allow the liquid to run through the bomb for at least 60 seconds
- E. Close the bottom valve on the bomb and allow it to fill
- F. Close top bomb valve and sample tap
- G. Remove bomb and place in 150°F stabilizing bath
- H. Once temp is stabilized at 150°F, proceed with normal determination of water

3.5.3 Range Change

It is always possible to reduce the span of an existing calibration simply by lowering the % water URV on the “Menu Screen”. If the reduction in span is greater than 20 or 30% of range, better accuracy can be usually achieved by changing the input/output curve to a lower range

When changing ranges on the Universal IV CM it is important to understand that the shape of the input/output curve may require revision, as well as the 100% point. The simplest way to re-range an instrument is to select a different input curve. Be sure to set the correct “Range Jumper” position indicated by the curve selected. This procedure can be performed on an installed instrument or in the shop, with the electronic unit itself.

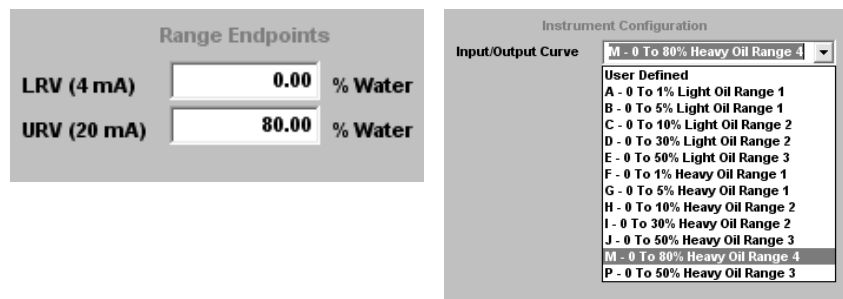

Captures from Main Screen

3.5.4 Strapping Table

If none of the available input/output curves are adequate for the application, a user defined table may have to be created. This is accomplished by editing the strapping table.

- A. With a PC connected to the signal loop (as in section 3.4) click on the strapping table button
- B. Click on Write Strapping Table button to re-range the transmitter to the new values.
- C. Click on the Exit to return to the “Menu Screen” It may be necessary to do a “One Shot” calibration on the installed instrument.



For user defined tables it will be necessary to adjust the URV (20 mA) point to the desired range (See section 3.8.3) and adjust the local indicator so that the maximum value is equal to the maximum % water in viewing % water is desired. It may also be necessary to adjust the jumpers to put the unit in the correct pF range.

3.5.5 Linearity Correction

On high water ranges (greater than 10%) the shape of the % Water/Capacitance curve will typically vary somewhat from one field to another. If it is determined that the output is accurate at high and low water levels, but incorrect at some intermediate area, it is possible to manipulate the break points in the strapping table to improve accuracy.

A step-by-step procedure is beyond the scope of this publication. Several AWT users have successfully trimmed the theoretical curve and in one case determined their own curve to satisfy particular conditions in their installation.

When attempting to optimize the input/output curve there are 3 precautions to keep in mind:

- A. Try to err on the side of under compensation for perceived deviations
- B. The top three points are designed to clip the output at 20 mA and should not be disturbed. They have no significant effect on the curve below 20 mA.
- C. Before beginning, be sure have a record of the starting curve, in case it becomes necessary to start over.

3.6 Set D/A Trim

D/A Trim is NOT a calibration! This is a pre calibrated alignment to precision factory settings and is rarely in need of change. The procedure is intended only as a slight "meter" adjustment to a known external reference.

The Digital to Analog (D/A) Trim adjusts the transmitter mA (current) output. Since the smart transmitter performs a digital to analog conversion, there may be a discrepancy in the 4-20 mA output loop as measured with a reliable external milliamperere meter.

For example: perhaps after calibration you observe that the tank is empty and a hand-held mA meter reads only 3.94 mA, while the Real Time View in the PC Menu shows 4.00 mA. By adjusting the D/A trim, you may digitally manipulate the output current to equal 4.00. You may also wish to adjust the high end to 20.00 mA.

To make these adjustments, click on **D/A Trim** on the PC software Menu Screen and follow the pop-up window instructions.

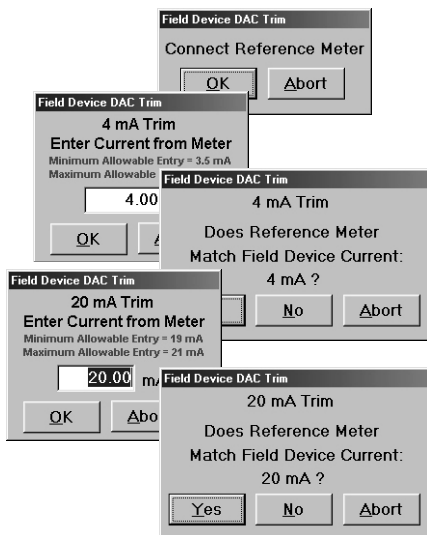

Setting D/A Trim Menu Screen Windows

3.7 Save/Print Entries

In addition to your own convenience, many regulatory agencies are requiring a record of the values being used during certain processes. All of the values developed in this configuration and calibration procedure may be saved to be reloaded into another (or replacement) transmitter. All of the values may likewise be printed out as hard copy, including the Serial Number, Transmitter Software Version, Tag ID, Scratch Pad, Instrument Calibration, all of the Real Time View numbers, and all of the Strapping Table entries.

Pop-up screens come from selections in the **FILE** pull down at the top left of the PC menu Screen.

Copies are saved in both .Universal IV CM file and .txt files.

The .Universal IV CM file will download into a transmitter through the **OPEN** command. The text file may be printed out, or reformatted.

PRINT command provides a pre-formatted hard copy.

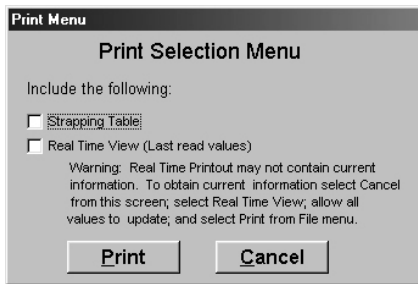

Print Pop-up from Menu

AMETEK Drexelbrook
 205 Keith Valley Road
 Horsham, PA 19044
 Telephone: 215-674-1234
 FAX: 215-674-2731
 Service: 800-527-6297

Tag-ID: LT-DEMO	Serial Number: 123456
Scratch Pad:	Software Version: 6.0
Damping Time: 0 sec.	Range Position: 4

Instrument Configuration	Range Endpoints
Input/Output Curve: M - 0 To 80% Heavy Oil Range 4	LRV (4 mA): 0.00 % Water
	URV (20 mA): 80.00 % Water

Real Time View

Percent Water:	55.00 %
Capacitance:	600.00 pF
Loop Current:	15.00 mA
Percentage:	68.75 %
Status:	OK

Input/Output Table

Number of Points: 15

Input pF	Output % Water
40.00	0.00
56.20	10.00
73.00	23.00
122.20	35.00
189.00	40.00
256.00	42.00
395.00	50.00
600.00	55.00
750.00	57.00
900.00	60.00
1100.00	65.00
2400.00	70.00
2700.00	75.00
2900.00	80.00
3450.00	83.00

3.8 Calibration & Configuration via Display/Keypad

To enter the Configuration Menu:

- Press and Hold the "Enter" Button for approximately 5 seconds.
- Use the "Up" and "Down" Buttons to scroll through the available menu selections.
- Press "Enter" to access sub-menu items.
- Use the "Up" and "Down" Buttons to adjust settings.
Settings that can be adjusted will be "flashing".
- Press "Enter" to accept the adjustment...Or...
- Press and Hold the "Enter" Button for approximately 5 seconds to exit to the previous menu level.



Menu Function (display abbreviation)	"Values (display abbreviat	Description
"Fct 1.00 Water Cut Ranges (RANGE)"		Select the water cut range for optimal measurement
	0 to 1% water in Light Oil (LIGHT A)	'Light Oil' is defined as oil with API Gravity less than 25. Heavy Oil is defined as oil with API Gravity greater than 25.
	0 to 5% water in Light Oil (LIGHT B) 0 to 10% water in Light Oil (LIGHT C) 0 to 30% water in Light Oil (LIGHT D) 0 to 50% water in Light Oil (LIGHT E) 0 to 1% water in Heavy Oil (HEAVY F) 0 to 5% water in Heavy Oil (HEAVY G) 0 to 10% water in Heavy Oil (HEAVY H) 0 to 30% water in Heavy Oil (HEAVY I) 0 to 50% water in Heavy Oil (HEAVY J) 0 to 80% water in Heavy Oil (HEAVY M) - Default	
	CUSTOM	Custom range requires a custom strapping table. See Fct 3.00
"Fct 2.00 Calibration (CAL)"		Enter this menu to calibrate the unit
"Fct 2.01 Indicated Calibration Point (IND CAL)"	% water - 0.0 Default	Enter the water cut reading captured at the time of taking the sample for calibration measurement
"Fct 2.02 Actual Calibration Point (ACT CAL)"	% water - 0.0 Default	Enter the actual water cut reading verified by another method of water cut measurement
"Fct 3.00 Strapping table (STRAP)"		Use this strapping table menu to define a custom range if selected in FCT 1.00. Otherwise the correct strapping table is automatically loaded when range is selected in FCT 1.00. Default values are for 'HEAVY M' range
"Fct 3.01 Maximum points (MAX PNT)"	15 (Default)	Enter the total number of points in the strapping table which is range dependent
"Fct 3.02 Point number index (INDEX)"	"1..MAX PNT 1 (Default)"	Enter the point number index
"Fct 3.03 Input value in PF (INPT #) "	Value in PF	Enter the capacitance value in pF
"Fct 3.04 Output value in water cut% (OUT #)"	Value in % water	Enter the cut value associate with the capacitance in pF and point index. Repeat FCT 3.02 to FCT 3.04 until all points are entered in the strapping table

3.8 Calibration & Configuration via Display/Keypad (Continued)

"Fct 4.00 Output (OUTPUT)"		Configure the output from the unit including LRV, URV, damping and fixed output
"Fct 4.01 Lower Range Value (LRV)"	0.0 (Default)	Enter the lower range value in % water equivalent to 4mA output
"Fct 4.02 Upper Range Value (URV)"	80.0 (Default)	Enter the upper range value in % water equivalent to 20mA output
"Fct 4.03 Damping in Seconds (DAMPING)"	0.0 (Default)	Enter damping in seconds to delay and filter (software RC filter) the output in case of rapid water cut variations
"Fct 4.04 4mA Trim (TRIM 4)"	4.00 (Default)	Use this menu to calibrate the 4 mA output which is not common practice. Requires calibrated meter to measure actual current output
"Fct 4.05 20mA Trim (TRIM 20)"	20.00 (Default)	Use this menu to calibrate the 20 mA output which is not common practice. Requires calibrated meter to measure actual current output
"Fct 4.06 Fixed Output (LOCK mA)"	0.00 (Default)	Use this menu to fix the output to a certain mA value regardless of the measurement. Enter the value in mA. The output will stay at this value until exiting the menu of if display times out in approx. 30 seconds
"Fct 4.07 Device ID (POLL)"	0 (Default)	Enter the device ID to be used on the HART loop. Each device on the loop must have a unique device ID. Change only for multi-drop configuration
"Fct 5.00 Display (DISPLAY)"		Setup the parameter(s) to be displayed on the unit during operation
"Fct 5.01 Toggle the display (TOGGLE?)"	NO (Default)	Toggle between enabled parameters. YES or NO
"Fct 5.02 Water Cut (H2O)"	ENABLE (Default)	Enable or disable water cut measurement display
"Fct 5.03 Capacitance (CAP)"	DISABLE (Default)	Enable or disable capacitance measurement in pF
"Fct 5.04 Calculated current (4--20)"	DISABLE (Default)	Enable or disable the calculated current output
"Fct 6.00 Service (SERVICE)"		Use this menu for troubleshooting and service
"Fct 6.01 Restore factory default (RST FAC)"	NO (Default)	Select YES to restore factory default in which case all paramaters will be replaced with factory default setting. Restoring the factory default will initiate this message on the display 'DEFAULT PARAMS SET' until power is cycled.
"Fct 6.02 Pad Capcitor in PF (PAD CAP)"	30.0 (Default)	Enter the value of an external capacitor that must be connected to the unit. Padding capacitors are used to reduce the sensing element standing capacitance in order to improve the measurement resolution
"Fct 6.03 Contrast (CONTRST)"	0 (Default)	0 is the highest contrast. 20 is the lowest contrast
"Fct 6.04 Parameter Number (PAR NUM)"	0	0 to 65535. Contact factory
"Fct 6.05 Parameter Offset (PAR OFS)"	0	Contact factory
"Fct 6.06 Parameter Value (PAR VAL)"	44	Contact factory

Section 4

Section 4: Specifications

4.1 Transmitter Specifications

Technology

RF Admittance / Capacitance

Supply Voltage

13-30VDC, 2-wire loop powered

Output/Digital Protocol

4-20mA, HART

Compatible with HART®

Accuracy and Resolution

Water Cut Range	Nominal Water Cut Variance*	Water Cut Resolution**
0 to 1%	+/- 0.03	0.0002
0 to 5%	+/- 0.04	0.0009
0 to 10%	+/- 0.04	0.0009
0 to 30%	+/- 0.12	0.0030
0 to 50%	+/- 0.35	0.0080
0 to 80% (Heavy Oil)	+/- 0.25	0.0035

* The measurement accuracy of an inline, dynamic water cut measurement is dependent upon many process variables including: oil dielectric consistency, fluid velocity at the sample point, mounting geometry and homogeneity of the oil/water emulsion. The values above represent nominal water cut measurement variances for a properly installed sensor under consistent measurement point conditions.

** The smallest water cut step that the instrument can resolve

Load Resistance

Maximum 550 ohms at 24 VDC

Minimum 250 ohms for HART protocol

Ambient Temperature

-40°C to 85°C (-40°F to 167°F)

Process Temperature

Up 232°C (450°F)

Process Pressure

Up 103 bar (1,500 psi), probe dependent

Process Connection

NPT, ANSI, and more upon request

Integral or Remote Configuration

25 ft max cable length for remote configuration

Response Time

350 msec nominal (no damping applied)

1-90 seconds programmable damping time

Supply Voltage Effect

0.2% of full scale max

Temperature Effect

0.5% per 100°F (37.7°C) change

Start-Up Time

< 12 seconds

Configuration and Calibration

Standard LCD display and keypad are built-in

HRTWIN™ PC-based software (free download)

Emission and Surge Protection

Compliant with IEC6100-4.2, 3, 4, 6, 8

Compliant with CISPR11 Group I, Class B

Approvals

Intrinsically Safe (IS)

Explosion Proof (XP) without IS barrier

FM, FMc, ATEX, IECEx

CE Mark



Section 5

Section 5: Normal Maintenance

5.1 Viewport Cleaning

The viewport (if supplied) is made of Borosilicate glass and can be cleaned with any common glass cleaning product (e.g.: Windex™, Isopropyl alcohol, etc.) that is suitable for the Class and Division rating of the specific system installation.

Section 6

Section 6: Hazardous Location Approval Supplementary Installation & Operating Instructions

6.1 General safety information

This document contains installation instructions for potentially explosive atmosphere applications.

The Universal UIV is approved for use in hazardous locations when properly installed. Control drawings detailing installation guidelines are available in **Section 8**.

Always Install to Local Codes / Requirements / Directives as Mandated by the Authority Having Jurisdiction.

The aluminum enclosure must be protected from mechanical friction and impact that could cause ignition capable sparks.

6.1.2 Warning



- Installation, Start-Up, and Service should only be performed by personnel trained in explosive atmosphere installations.
- Substitution of Components May Impair Intrinsic Safety.

6.1.3 Device Description

The Universal IV is a Continuous Level Measurement System. Measurements are displayed via remote communications or an integrated display screen.

6.1.4 Electrical connection

WARNING! Read the following information carefully.



- Live Maintenance should only be carried out by Skilled Personnel trained in explosion protection methods.
- Test Equipment used to perform “Live Maintenance” must be certified to use in the associated hazardous area.

Intrinsically Safe Installations



When the Universal IV is installed as an intrinsically safe device per the agency control drawings, the housing cover may be safely opened. For system configuration, remove the view port housing cover to access the display keypad for local system configuration.

Explosionproof or Flameproof Installations



No Live maintenance is permitted. Disconnect power to the device and check that the atmosphere is clear of hazardous substances.

6.1.5 Commissioning

Start-up checklist



Do not connect power until you have gone through the checklist below

1. Are the wetted components (gasket, flange and sensing element) resistant to the corrosive properties of the tank product?
2. Does the information given on the nameplate correspond with the application?
3. Ex d applications: Have you connected the equipotential bonding system correctly?
4. Ex i applications: Are you using an intrinsic barrier within the correct parameters?
5. Did you install cable entries of the correct internal diameter so that there is a good seal around the cable? Are the cable glands suitably certified per the application and the hazardous area parameters?
6. Do not use the earth terminal in the wiring compartment: use the equipotential bonding system.

6.2 The Compartment Cover

Viewport Cleaning: The viewport is made of Borosilicate glass and can be cleaned with any common glass cleaning product (e.g.: Windex™, Isopropyl alcohol, etc.) that is suitable for the Class and Division rating of the specific system installation.

6.2.1 Opening the cover

Procedure

1. Unscrew cover stop, if applicable
2. Unscrew terminal compartment cover

6.2.2 Closing the cover



Warning: Ex d [ia] applications

Check that the terminal compartment cover is screwed tight and the cover stop (if applicable) is fastened tightly to the cover.

6.3 Standards and Approvals

6.3.1 FM US Approvals - Install per 420-0004-412-CD

The Universal IV Level Transmitter is rated as Intrinsically Safe for Class I, II and III, Groups A-G and Class I, Zone 0, Group IIC, in accordance with drawing 420-0004-412-CD; Nonincendive Class I, Division 2, Groups A-D Hazardous (Classified) Locations.

Furthermore, the Integral version is rated as Explosionproof for Class I, Division 1, Groups C & D; Dust Ignitionproof for Class II & III, Division 1, Groups E-G and Class I, Zone 1, Group IIB Hazardous (Classified) Locations with an integral sensor that is Intrinsically Safe for Class I, II & III, Groups A-G and Class I, Zone 1 Hazardous (Classified) Locations. The Remote version is rated as Explosionproof Class I, Division 1, Groups C & D; Dust-Ignitionproof for Class II & III, Division 1, Groups E-G and Class I, Zone 1, Group IIB Hazardous (Classified) Locations with connections to a 700 Series sensor that is Intrinsically Safe for Class I, II & III, Groups A-G and Class I, Zone 1 Hazardous (Classified) Locations.

6.3.2 FM Canada Approvals - Install per 420-0004-412-CD

The Universal IV Level Transmitter is rated as Intrinsically Safe for Class I, II and III, Groups A-G and Class I, Zone 0, Group IIC, in accordance with drawing 420-0004-412-CD; Nonincendive Class I, Division 2, Groups A-D Hazardous Locations.

Furthermore, the Integral version is rated as Explosionproof for Class I, Division 1, Groups C & D; Dust Ignitionproof for Class II & III, Division 1, Groups E-G and Class I, Zone 1, Group IIB Hazardous Locations with an integral sensor that is Intrinsically Safe for Class I, II & III, Groups A-G and Class I, Zone 1 Hazardous Locations. The Remote version is rated as Explosionproof Class I, Division 1, Groups C & D; Dust-Ignitionproof for Class II & III, Division 1, Groups E-G and Class I, Zone 1, Group IIB Hazardous Locations with connections to a 700 Series sensor that is Intrinsically Safe for Class I, II & III, Groups A-G and Class I, Zone 1 Hazardous Locations.

6.3 Standards and Approvals (Continued)

6.3.3 ATEX Approvals - Install per 420-0004-024-CD

Universal IV Level Transmitter – Integral

II 1 G Ex ia IIC T4 Ga $-40^{\circ}\text{C} \leq T_{\text{amb}} \leq +75^{\circ}\text{C}$; IP66 (For models U**103**00-*.*)

II 2 G Ex d ia IIB T4 Gb $-40^{\circ}\text{C} \leq T_{\text{amb}} \leq +75^{\circ}\text{C}$; IP66 (For models U**104**00-*.*)

II 2 D Ex tb ia IIIC Db T90°C $-40^{\circ}\text{C} \leq T_{\text{amb}} \leq +75^{\circ}\text{C}$; IP66 (For models U**104**00-*.*)

Universal IV Level Transmitter – Remote (excluding models U**10***00-*.*)

II 1 G Ex ia IIC T4 $-40^{\circ}\text{C} \leq T_{\text{amb}} \leq +75^{\circ}\text{C}$; IP66 (For models U**103***0-*.*)

II 2 (1) G Ex d [ia] IIB T4 $-40^{\circ}\text{C} \leq T_{\text{amb}} \leq +75^{\circ}\text{C}$; IP66 (For models U**104***0-*.*)

II 2 (1) D Ex tb [ia] IIIC T90°C $-40^{\circ}\text{C} \leq T_{\text{amb}} \leq +75^{\circ}\text{C}$; IP66 (For models U**10***0-*.*)

700-*, Universal IV Sensors

II 1 G Ex ia IIC T2...T5 Ga $-40^{\circ}\text{C} \leq T_{\text{amb}} \leq +75^{\circ}\text{C}$

II 1 D Ex ia IIIC T300°C...T90°C Da $-40^{\circ}\text{C} \leq T_{\text{amb}} \leq +75^{\circ}\text{C}$

6.3.4 IECEx Approvals - Install per 420-0004-024-CD

Integral:

Ex ia IIC T4 Ga; Ex d ia IIB T4 Gb; Ex tb ia IIIC T90°C Db; $-40^{\circ}\text{C} \leq T_{\text{a}} \leq +75^{\circ}\text{C}$; IP66

Input Voltage: 13-30Vdc; 1W

Remote:

Ex ia IIC T4 Ga; Ex tb [ia] IIIC T90°C Db; Ex d [ia] IIB T4 Gb; Ex tb [ia] IIIC T90°C Db; $-40^{\circ}\text{C} \leq T_{\text{a}} \leq +75^{\circ}\text{C}$; IP66

Input Voltage: 13-30Vdc; 1W

Remote Sensor:

Ex ia IIC T5 ... T2 Ga; Ex ia IIIC T90°C ... T300°C Da; $-40^{\circ}\text{C} \leq T_{\text{a}} \leq +75^{\circ}\text{C}$; IP66

Section 7: Control Drawings

7.1 ATEC / IECEX

NO. 420-0004-424-CD SHT 1 OF 8

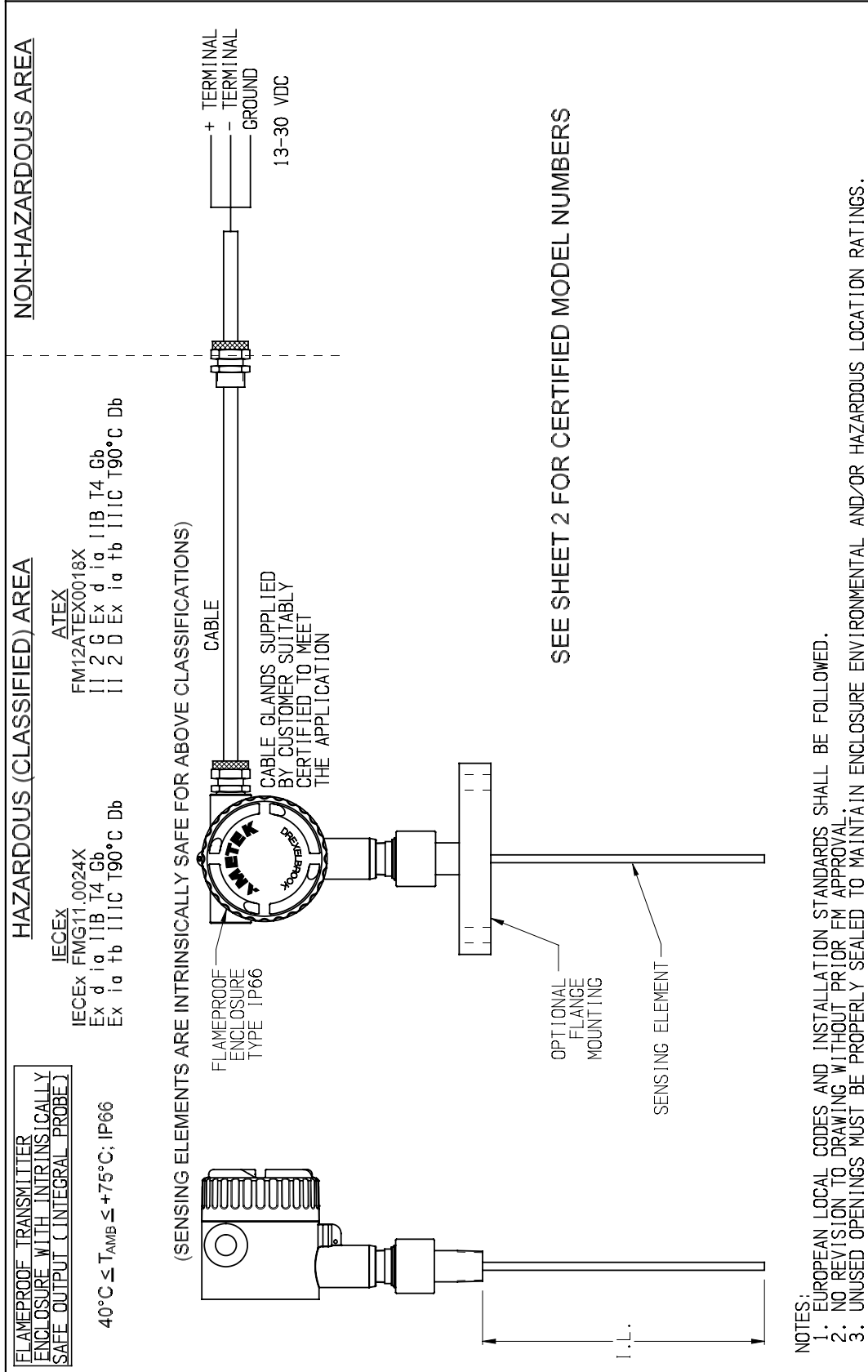

- NOTES:
1. EUROPEAN LOCAL CODES AND INSTALLATION STANDARDS SHALL BE FOLLOWED.
 2. NO REVISION TO DRAWING WITHOUT PRIOR FM APPROVAL.
 3. UNUSED OPENINGS MUST BE PROPERLY SEALED TO MAINTAIN ENCLOSURE ENVIRONMENTAL AND/OR HAZARDOUS LOCATION RATINGS.

CERTIFIED by _____		COPYRIGHT 2012		FM - ATEX - IECEX CONTROL DRAWING FOR UNIVERSAL IV (INTEGRAL) FLAMEPROOF INSTALLATION	
PO # _____	AMETEK DREXELBROOK	SCALE NONE		ISS. SHT. 1 OF 8	
ENG _____	UNLESS OTHERWISE STATED ALL DIMENSIONS IN INCHES (M)	2	5-11-107	SGA	420-0004-424-CD
USER _____	DR. JJS 5-2-12	1	5-11-107	SGA	SHT. 1 OF 8
DATE _____	LEP 5-18-12	ISS. EDD/DSR NO. APP'D	DATE	CK.	420-0004-424-CD
DE # _____					ISS. SHT. 1 OF 8

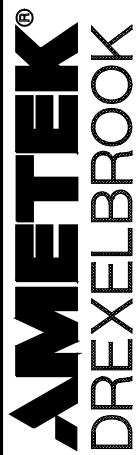

205 KEITH VALLEY RD
HORSHAM, PA. 19044-9986
215-674-1234
FAX 215-674-2731

7.1 ATEC / IECEX (Continued)

No. 420-0004-424-CD SHEET 2 OF 8

SPECIFIC CONDITIONS FOR USE:
 THE APPARATUS ENCLOSURE CONTAINS ALUMINUM AND IS CONSIDERED TO
 CONSTITUTE A POTENTIAL RISK OF IGNITION BY IMPACT OR FRICTION. CARE
 MUST BE TAKEN INTO ACCOUNT DURING INSTALLATION AND USE TO PREVENT
 IMPACT OR FRICTION.

CERTIFIED MODELS

Uab10cd000-e-f. Universal IV - Flameproof - Model Code

- a = TYPE P, L, OR C.
- b = FREQUENCY AND PHASING 0, 1, 2, OR 3
- c = APPROVAL 4 (ATEX), 6 (IECEX)
- d = ENTRIES 1 OR 2
- e = SENSING ELEMENT 251, 252, 253, 254, 255, 256, 257, 258, 259, 260, 261,
OR 262
- f = 24 CHARACTER NUMBERING SYSTEM THAT DOES NOT AFFECT SAFETY

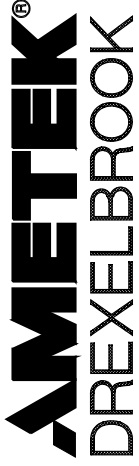
CERTIFIED							
PO #	by						
ENG							
USER							
		2	5-11-107	SCA	5-2-12		
		1	5-11-107	SCA	4-6-12		
DE #		ISS, EDO/DSR NO.	APP'D	DATE	DR.	JUS 5-2-12	CK. LEP 5-18-12
				COPYRIGHT 2012		AMETEK DREXELBROOK	
				SCALE NONE		UNLESS OTHERWISE STATED	
				ALL DIMENSIONS IN INCHES (MM)			
							
						205 KEITH VALLEY RD HORSHAM, PA 19044-9886 215-674-1234 FAX 215-674-2731	
						FM - ATEX - IECEX CONTROL DRAWING FOR UNIVERSAL IV (INTEGRAL) FLAMEPROOF INSTALLATION	
						420-0004-424-CD SHEET 2 OF 8	

7.1 ATEC / IECEX (Continued)

NO. 420-0004-424-CD

SHT 3 OF 8

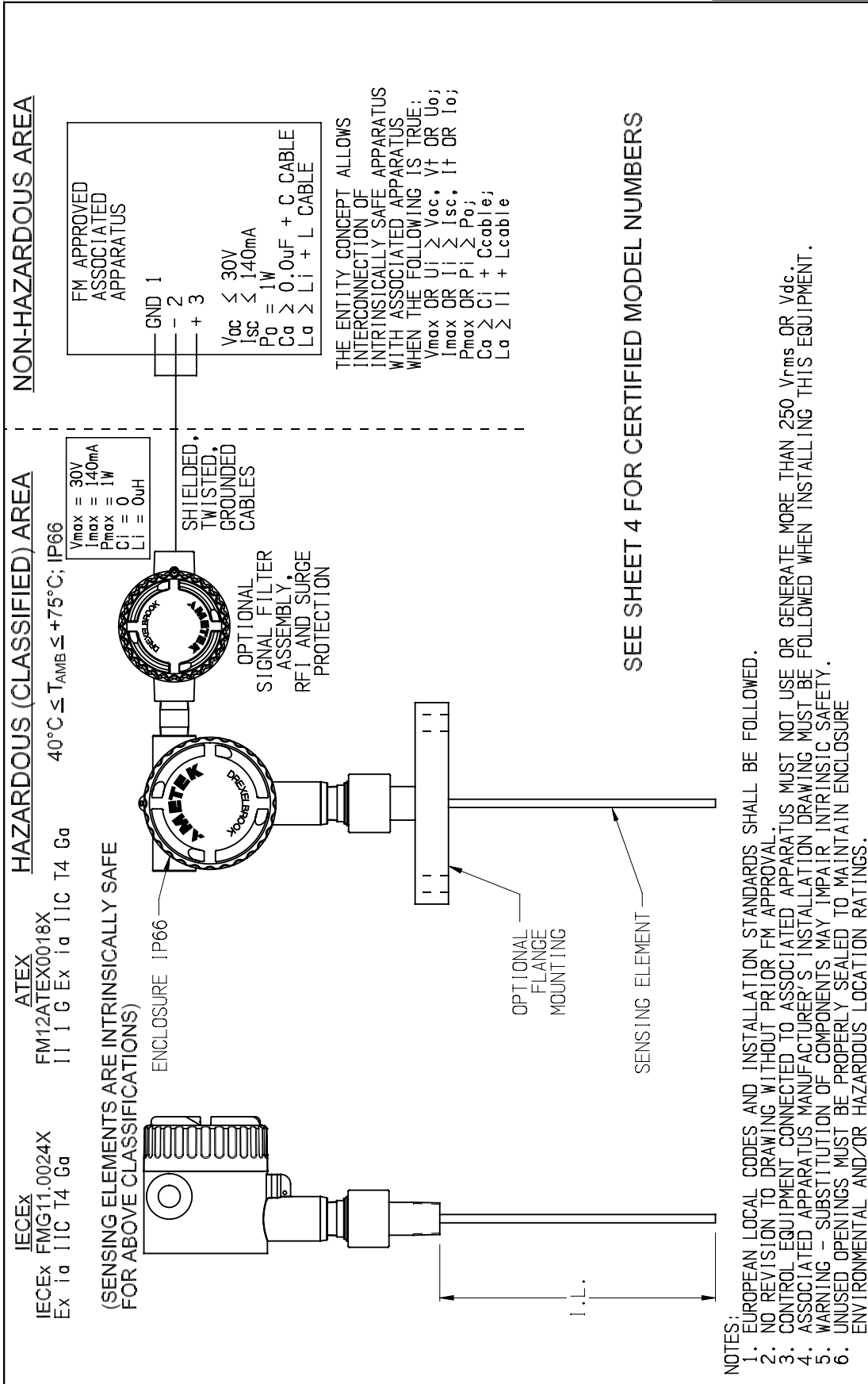

- NOTES:
1. EUROPEAN LOCAL CODES AND INSTALLATION STANDARDS SHALL BE FOLLOWED.
 2. NO REVISION TO DRAWING WITHOUT PRIOR FM APPROVAL.
 3. CONTROL EQUIPMENT CONNECTED TO ASSOCIATED APPARATUS MUST NOT USE OR GENERATE MORE THAN 250 V_{rms} OR V_{dc}.
 4. ASSOCIATED APPARATUS MANUFACTURER'S INSTALLATION DRAWING MUST BE FOLLOWED WHEN INSTALLING THIS EQUIPMENT.
 5. WARNING - SUBSTITUTION OF COMPONENTS MAY IMPAIR INTRINSIC SAFETY.
 6. UNUSED OPENINGS MUST BE PROPERLY SEALED TO MAINTAIN ENCLOSURE ENVIRONMENTAL AND/OR HAZARDOUS LOCATION RATINGS.

CERTIFIED	by _____	COPYRIGHT 2012	AMETEK DREXELBROOK
PO # _____		SCALE NONE	UNLESS OTHERWISE STATED ALL DIMENSIONS IN INCHES (MM)
ENG _____		2	5-11-107 SGA 5-2-12
USER _____		1	5-11-107 SGA 4-6-12
ISS # _____	EDD/DSR NO. APP' D	DATE	DR. JJS 5-2-12
DE # _____			CK. LEP 5-18-12

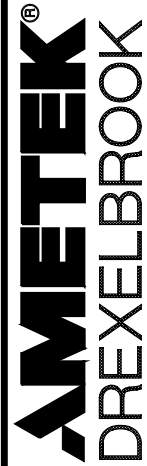

205 KEITH VALLEY RD
HORSHAM, PA 19044-9966
215-674-1234
FAX 215-674-2731

FM - ATEX - IECEX
CONTROL DRAWING FOR
UNIVERSAL IV (INTEGRAL)
IS ENTITY INSTALLATION

420-0004-424-CD
SHT. 3 OF 8

7.1 ATEX / IECEX (Continued)

No. 420-0004-424-CD SHT 4 OF 8

SPECIFIC CONDITIONS FOR USE:
 THE APPARATUS ENCLOSURE CONTAINS ALUMINUM AND IS CONSIDERED TO CONSTITUTE A POTENTIAL RISK OF IGNITION BY IMPACT OR FRICTION. CARE MUST BE TAKEN INTO ACCOUNT DURING INSTALLATION AND USE TO PREVENT IMPACT OR FRICTION.

CERTIFIED MODELS

Uab10cde00-f-g. Universal IV - Integral Intrinsically Safe - Model Code

- a = TYPE P, L, OR C.
- b = FREQUENCY AND PHASING 0, 1, 2, OR 3
- c = APPROVAL 3 (ATEX), 5 (IECEX)
- d = ENTRIES 1 OR 2
- e = SURGE SUPPRESSION 0 OR 1
- f = SENSING ELEMENT R00, R01, R02, R03, R04, R05, 251, 252, 253, 254, 255, 256, 257, 258, 259, 260, 261, 262, 301, 302, 303, 304, 305, 306, 307, 308, 309, 310, 311, 312, 313, 314, 315, 316, 317, 318, 319, 320, 321, 322, 323, 324, 325, 326, 327, 328, 329, 330, 331, 332, 333, 334, 335, 501, 502, 503, 504, 505, 506, 507, 508, 509, 510, 511, 512, 513, 601, 603, 604, 605, 606, 607, 608, 609, 610, 611, 613, 703, 705, 706, 708, 709, 713, 714, 715, 722, OR ZZZ
- g = 24 CHARACTER NUMBERING SYSTEM THAT DOES NOT AFFECT SAFETY

ZZZ = SPECIAL SENSING ELEMENT
 700- ANY 7 DIGIT NUMERIC COMBINATION

NOTES:

1. MAXIMUM PROCESS TEMPERATURE 290°C
2. MAXIMUM SENSOR CAPACITANCE < 1uF
3. MAXIMUM INSERTION LENGTH **RIGID SENSOR** 30 FEET (9.144 METERS)
4. MAXIMUM INSERTION LENGTH **FLEXIBLE SENSOR** 2000 FEET (609.6 METERS)
5. SENSING ELEMENT ENCLOSURE IP66 (IP RATING DOES NOT APPLY TO SPECIAL SENSORS SUPPLIED WITHOUT A 285- SERIES SENSING ELEMENT ENCLOSURE).

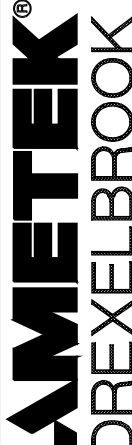
CERTIFIED	by _____	COPYRIGHT 2012		FM - ATEX - IECEX CONTROL DRAWING FOR UNIVERSAL IV (INTEGRAL) IS ENTITY INSTALLATION
PO # _____		AMETEK DREXELBROOK		
ENG _____		SCALE NONE	205 KEITH VALLEY RD HODESHAM, PA 19044-9986 215-674-1234 FAX 215-674-2731	SHT. 4 OF 8
USER _____		UNLESS OTHERWISE STATED ALL DIMENSIONS IN INCHES (MM)		
	2 5-11-107 SGA 5-2-12	DR. JJS 5-2-12		420-0004-424-CD SHT. 4 OF 8
	1 5-11-107 SGA 4-6-12	CK. LEP 5-18-12		
DE # _____	ISS. EDO/DSR NO. APP/D	DATE		ISS. 2

7.1 ATEX / IECEX (Continued)

No. 420-0004-424-CD

SHT 5 OF 8

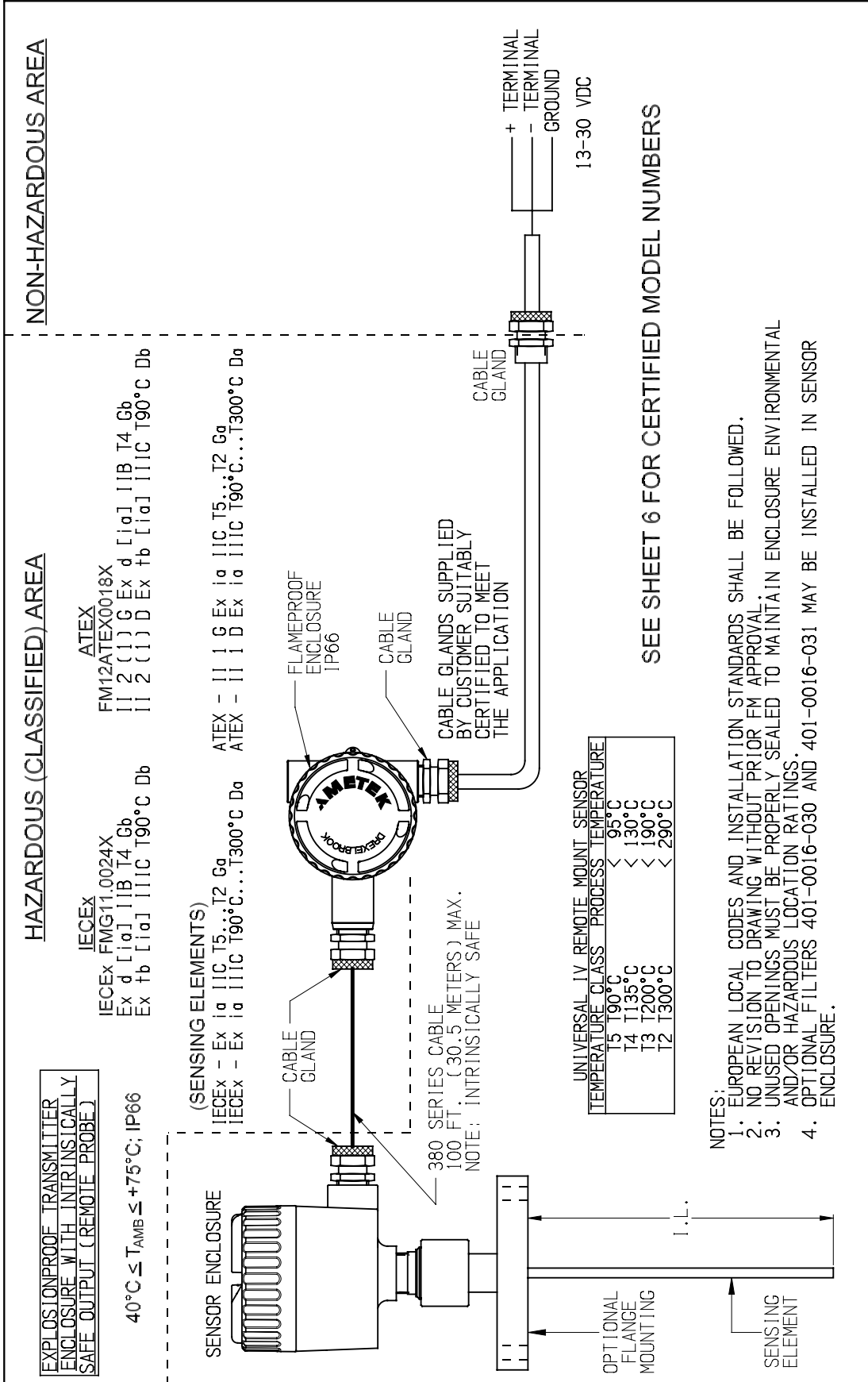

SEE SHEET 6 FOR CERTIFIED MODEL NUMBERS

FM - ATEX - IECEX CONTROL DRAWING FOR UNIVERSAL I.V. (REMOTE) FLAMEPROOF INSTALLATION	
420-0004-424-CD	SHT. 5 OF 8

AMETEK®
DREXELBROOK

205 KEITH VALLEY RD
 HOBBSHAW, PA 19044-9986

215-674-1234
 FAX 215-674-2731

CERTIFIED	by _____
PO #	
ENG	
USER	
ISS. EDO/DSR NO./APP'D	DATE
2	5-11-107 SGA 5-2-12
1	5-11-107 SGA 4-6-12
DR. JJS 5-2-12	CK. LEP 5-18-12
COPYRIGHT 2012 AMETEK DREXELBROOK	
SCALE NONE UNLESS OTHERWISE STATED ALL DIMENSIONS IN INCHES (UN)	

7.1 ATEX / IECEX (Continued)

SPECIFIC CONDITIONS FOR USE:
 THE APPARATUS ENCLOSURE CONTAINS ALUMINUM AND IS CONSIDERED TO CONSTITUTE A POTENTIAL RISK OF IGNITION BY IMPACT OR FRICTION. CARE MUST BE TAKEN INTO ACCOUNT DURING INSTALLATION AND USE TO PREVENT IMPACT OR FRICTION.

CERTIFIED MODELS

Uab10cdef0-g-h. Universal IV - Remote Flameproof - Model Code

q = TYPE P, L, OR C.
 b = FREQUENCY AND PHASING 0, 1, 2, OR 3
 c = APPROVAL 4 (ATEX), 6 (IECEX)
 d = ENTRIES 1 OR 2
 e = SURGE SUPPRESSION 0, 4, OR D
 f = REMOTE CONFIGURATION 1, 2, 3, 4, 5, 6, 7, 8, 9, A, B, C, D, E, F, G, H, J, K, L, M, N, P, R, S, OR Z
 g = SENSING ELEMENT R09, 000, 101, 102, 103, 104, 105, 106, 107, 108, 109, 110, 111, 112, 113, 301, 302, 303, 304, 305, 306, 307, 308, 309, 310, 311, 312, 313, 314, 315, 316, 317, 318, 319, 320, 321, 322, 323, 324, 325, 326, 327, 328, 329, 330, 331, 332, 333, 334, 335, 501, 502, 503, 504, 505, 506, 507, 508, 509, 510, 513, 601, 603, 604, 605, 606, 607, 608, 609, 610, 611, 612, 613, 701, 702, 703, 704, 705, 706, 707, 708, 709, 710, 711, 712, 713, 714, 715, 716, 717, 718, 719, 720, 721, 722, 723, 724, 725, 726, 727, 728, 729, 730, 731, 732, 735, 736, 737, 738, 739, 740, 741, 742, 743, 744, 745, 746, 747, 748, 749, 750, 751, 752, OR ZZZ*
 h = 24 CHARACTER NUMBERING SYSTEM THAT DOES NOT AFFECT SAFETY.

ZZZ = SPECIAL SENSING ELEMENT
 700- ANY 7 DIGIT NUMERIC COMBINATION

NOTES:

1. MAXIMUM PROCESS TEMPERATURE 290°C
2. MAXIMUM SENSOR CAPACITANCE < 1µF
3. MAXIMUM INSERTION LENGTH **RIGID SENSOR** 30 FEET (9.144 METERS)
4. MAXIMUM INSERTION LENGTH **FLEXIBLE SENSOR** 2000 FEET (609.6 METERS)
5. SENSING ELEMENT ENCLOSURE IP66 (IP RATING DOES NOT APPLY TO SPECIAL SENSORS SUPPLIED WITHOUT A 285- SERIES SENSING ELEMENT ENCLOSURE).

CERTIFIED PO # _____ ENG _____ USER _____ _____ DE # _____	by _____ _____ _____ _____ _____	COPYRIGHT © 2012 AMETEK DREXELBROOK SCALE NONE UNLESS OTHERWISE STATED ALL DIMENSIONS IN INCHES (MM)	DR. JUS 5-2-12 LEP 5-18-12 DATE	FM - ATEX - IECEX CONTROL DRAWING FOR UNIVERSAL IV (REMOTE) FLAMEPROOF INSTALLATION	ISS. 6 OF 8 420-0004-424-CD SH 6 OF 8
---	--	--	---------------------------------------	--	---



215-674-1234
 FAX 215-674-2731

205 KEITH VALLEY RD
 HORSHAM, PA 19044-9986

7.1 ATEC / IECEX (Continued)

№. 420-0004-424-CD SHT 7 OF 8

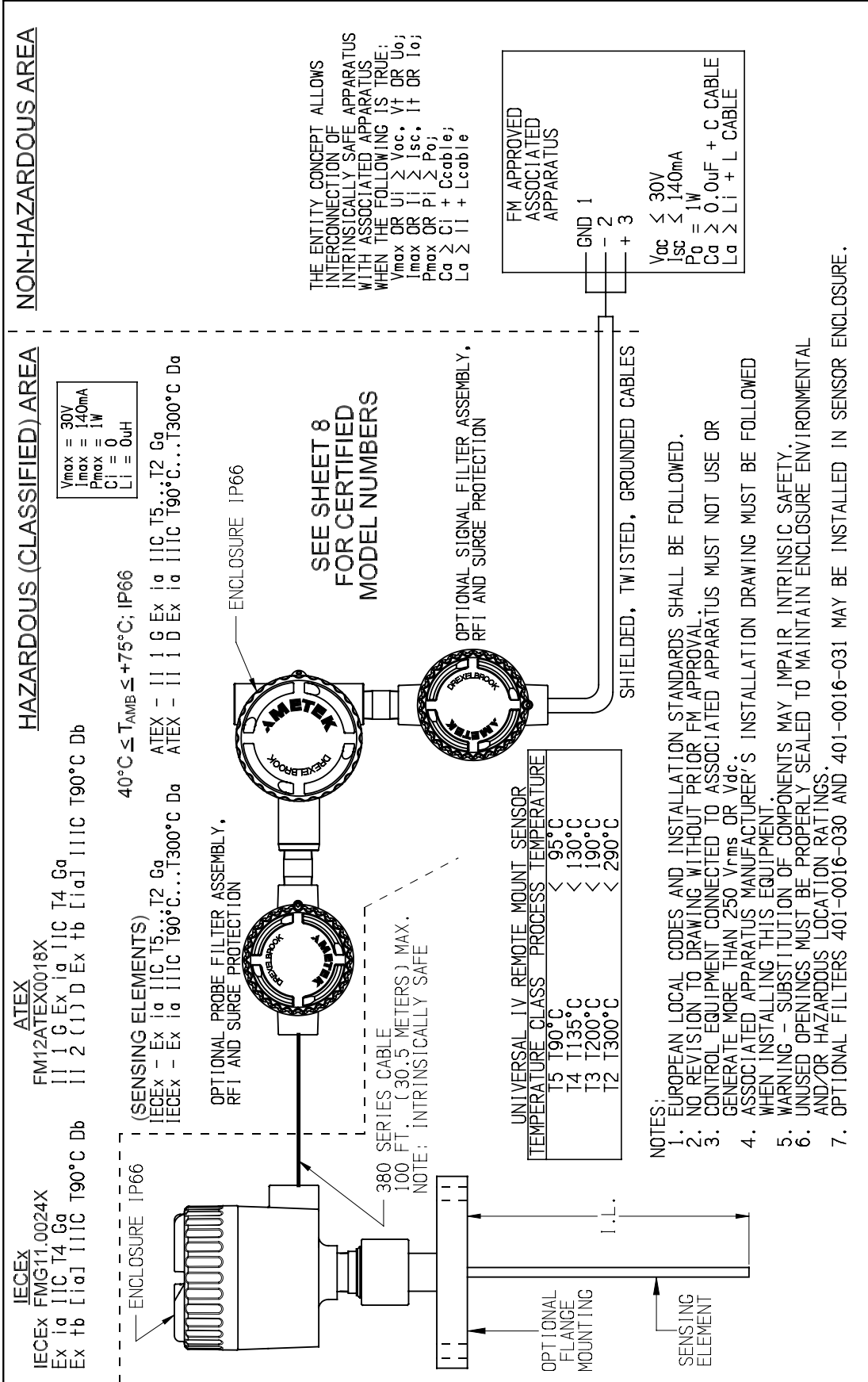

CERTIFIED	by _____	COPYRIGHT 2012	AMETEK DREXELBROOK
PG #		SCALE	NONE
ENG		UNLESS OTHERWISE STATED	
USER		2	5-11-107 SGA 5-2-12
		1	5-11-107 SGA 4-6-12
ISS. EDO/DSR NO.	APP' D	DATE	
ISS. #		DR. JJS 5-2-12	
		CK. LEP 5-18-12	

205 KEITH VALLEY RD
 HORSHAM, PA 19044-9986

215-674-1234
 FAX 215-674-2731

FM - ATEX - IECEX
 CONTROL DRAWING FOR
 UNIVERSAL IV (REMOTE)
 IS ENTITY INSTALLATION

420-0004-424-CD SHT. 7 OF 8

7.1 ATEX / IECEX (Continued)

SPECIFIC CONDITIONS FOR USE:
 THE APPARATUS ENCLOSURE CONTAINS ALUMINUM AND IS CONSIDERED TO CONSTITUTE A POTENTIAL RISK OF IGNITION BY IMPACT OR FRICTION. CARE MUST BE TAKEN INTO ACCOUNT DURING INSTALLATION AND USE TO PREVENT IMPACT OR FRICTION.

CERTIFIED MODELS

Uab10cdef0-g-h. Universal IV - Remote Intrinsically Safe - Model Code

- a = TYPE P, L, OR C.
- b = FREQUENCY AND PHASING 0, 1, 2, OR 3
- c = APPROVAL 3 (ATEX), 5 (IECEX)
- d = ENTRIES 1 OR 2
- e = SURGE SUPPRESSION 0, 1, 2, 3, 4, 5, 6, 7, OR D
- f = REMOTE CONFIGURATION 1, 2, 3, 4, 5, 6, 7, 8, 9, A, B, C, D, E, F, G, H, J, K, L, M, N, P, R, S, OR Z
- g = SENSING ELEMENT R09, 000, 101, 102, 103, 104, 105, 106, 107, 108, 109, 110, 111, 112, 113, 301, 302, 303, 304, 305, 306, 307, 308, 309, 310, 311, 312, 313, 314, 315, 316, 317, 318, 319, 320, 321, 322, 323, 324, 325, 326, 327, 328, 329, 330, 331, 332, 333, 334, 335, 501, 502, 503, 504, 505, 506, 507, 508, 509, 510, 513, 601, 603, 604, 605, 606, 607, 608, 609, 610, 611, 612, 613, 701, 702, 703, 704, 705, 706, 707, 708, 709, 710, 711, 712, 713, 714, 715, 716, 717, 718, 719, 720, 721, 722, 723, 724, 725, 726, 727, 728, 729, 730, 731, 732, 735, 736, 737, 738, 739, 740, 741, 742, 743, 744, 745, 746, 747, 748, 749, 750, 751, 752, OR ZZZ*
- h = 24 CHARACTER NUMBERING SYSTEM THAT DOES NOT AFFECT SAFETY

ZZZ = SPECIAL SENSING ELEMENT
 700- ANY 7 DIGIT NUMERIC COMBINATION

NOTES:

1. MAXIMUM PROCESS TEMPERATURE 290°C
2. MAXIMUM SENSOR CAPACITANCE < 1uF
3. MAXIMUM INSERTION LENGTH **RIGID SENSOR** 30 FEET (9.144 METERS)
4. MAXIMUM INSERTION LENGTH **FLEXIBLE SENSOR** 2000 FEET (609.6 METERS)
5. SENSING ELEMENT ENCLOSURE IP66 (IP RATING DOES NOT APPLY TO SPECIAL SENSORS SUPPLIED WITHOUT A 285- SERIES SENSING ELEMENT ENCLOSURE).

CERTIFIED		COPYRIGHT 2012			
PO #		AMETEK DREXELBROOK			
ENG		SCALE NONE			
USER		<small>UNLESS OTHERWISE STATED ALL DIMENSIONS IN INCHES (MM)</small>			
	2	5-11-107	SGA	5-2-12	
	1	5-11-107	SGA	4-6-12	
ISS/EDD/DSR NO.		APP'D	DATE	DR. JJS 5-2-12	CK. LEP 5-18-12
DE #					

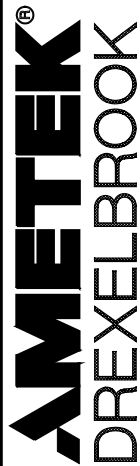

215-674-1234
FAX 215-674-2731

205 KEITH VALLEY RD
HORSHAM, PA 19044-9986

FM - ATEX - IECEX
CONTROL DRAWING FOR
UNIVERSAL IV (REMOTE)
IS ENTRY INSTALLATION

420-0004-424-CD SHEET 8 OF 8

7.2 FM US / FMC (Continued)

NO. 420-0004-412-CD SHT 2 OF 16

SPECIFIC CONDITIONS FOR USE:
 THE APPARATUS ENCLOSURE CONTAINS ALUMINUM AND IS CONSIDERED TO
 CONSTITUTE A POTENTIAL RISK OF IGNITION BY IMPACT OR FRICTION. CARE
 MUST BE TAKEN INTO ACCOUNT DURING INSTALLATION AND USE TO PREVENT
 IMPACT OR FRICTION.

CERTIFIED MODELS

Uab102cd00ef

- a = TYPE P, L, OR C.
- b = FREQUENCY AND PHASING 0, 1, 2, 3
- c = ENTRIES 0, 2
- d = SURGE/NOISE SUPPRESSION 0, 1
- e = SENSING ELEMENT: R111, R112, R113, R114, R115, 251, 252, 253, 254, 255,
 256, 257, 258, 260, 261, 262, 301, 302, 303, 304,
 305, 306, 307, 308, 309, 310, 311, 312, 313, 314, 315,
 316, 317, 318, 319, 320, 321, 322, 323, 324, 325, 326,
 327, 502, 503, 504, 505, 506, 507, 508, 510, 511, 512
- f = 24 CHARACTER NUMBERING SYSTEM THAT DOES NOT AFFECT SAFETY



215-674-1294
 215-674-2731
 205 KEITH VALLEY RD
 HORSHAM, PA 19044-9986

FM/FMC CONTROL DRAWING FOR
 UNIVERSAL IV
 (INTEGRAL) XP INSTALLATION
 420-0004-412-CD
 SHT. 2 OF 3

CERTIFIED	by _____	COPYRIGHT 2012	AMETEK DREXELBROOK
PO # _____			
ENG _____	5-3-12	SCALE NONE	UNLESS OTHERWISE STATED
USER _____	5-11-107 SGA	4-9-12	ALL DIMENSIONS IN INCHES (MM)
ISS/EDD/DSR NO. APP' D	5-11-107 SGA	5-20-11	DR. JUS 5-2-12
DATE			CK. _____

7.2 FM US / FMC (Continued)

NO. 420-0004-412-CD SHT. 4 OF 16

SPECIFIC CONDITIONS FOR USE:
 THE APPARATUS ENCLOSURE CONTAINS ALUMINUM AND IS CONSIDERED TO
 CONSTITUTE A POTENTIAL RISK OF IGNITION BY IMPACT OR FRICTION. CARE
 MUST BE TAKEN INTO ACCOUNT DURING INSTALLATION AND USE TO PREVENT
 IMPACT OR FRICTION.

CERTIFIED MODELS

Uab102cd01ef

- a = TYPE P, L, OR C.
- b = FREQUENCY AND PHASING 0, 1, 2, 3
- c = ENTRIES 0, 2
- d = SURGE/NOISE SUPPRESSION 0, 1
- e = SENSING ELEMENT: 101, 102, 103, 104, 105, 106, 107, 108, 109, 110, 111, 112, 113, 301, 302, 303, 304, 305, 306, 307, 308, 309, 310, 311, 312, 313, 314, 315, 316, 317, 318, 319, 320, 321, 322, 323, 324, 325, 326, 327
- f = 24 CHARACTER NUMBERING SYSTEM THAT DOES NOT AFFECT SAFETY

CERTIFIED		by		COPYRIGHT 2012		AMETEK DREXELBROOK		FM/FMC CONTROL DRAWING FOR UNIVERSAL IV (INTEGRAL) XP INSTALLATION DUAL SEAL OPTION	
PO #									ISS. OF
ENG									SHT. 4
USER									OF 16
									3
DE #									420-0004-412-CD
				SCALE NONE		UNLESS OTHERWISE STATED		215-874-1294	
				ALL DIMENSIONS IN INCHES (MM)		DR. JUS 5-2-12		FAX 215-874-2793	
				ISS. EDD/DSR NO. APP'D		DATE		205 KEITH VALLEY RD	
				ISS. EDD/DSR NO. APP'D		DATE		PORSHEM, PA 19044-9956	



7.2 FM US / FMC (Continued)

No. 420-0004-412-CD

SHT 5 OF 16

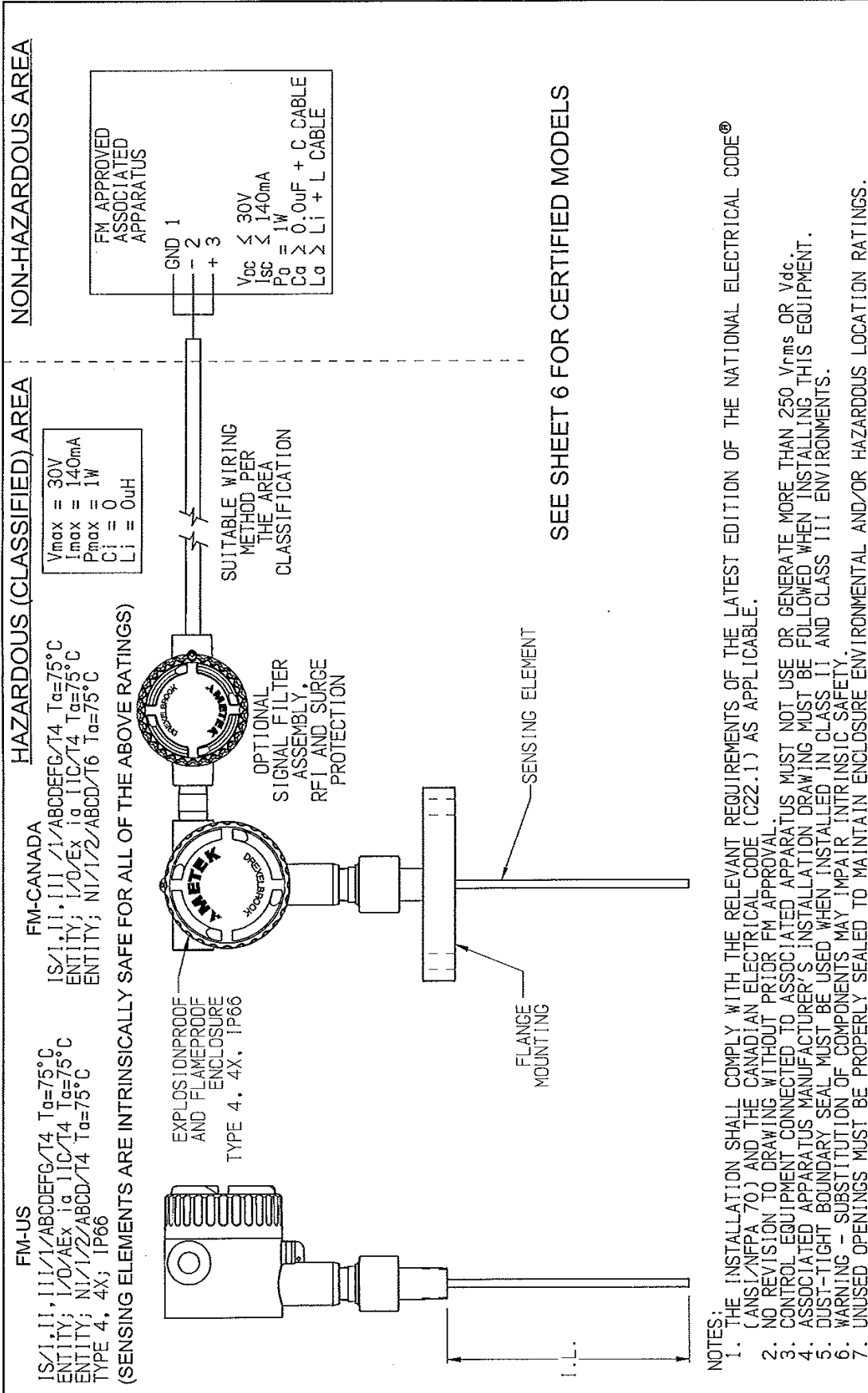

NON-HAZARDOUS AREA

FM/FMc CONTROL DRAWING FOR UNIVERSAL TV (INTEGRAL) IS ENTITY INSTALLATION

420-0004-412-CD

SHT. 5 OF 16

AMETEK®
DREXELBROOK

205 KEITH VALLEY RD
HORSHAM, PA 19044-9986

215-674-1294
FAX 215-674-2731

CERTIFIED	by	DATE
PO #		
ENG	3 5-11-107	
USER	2 5-11-107 SGA	4-9-12
ISS. EDD/DSR NO. APP' D	1 5-11-107 SGA	5-20-11
DE #		
COPYRIGHT 2012 AMETEK DREXELBROOK		
SCALE NONE UNLESS OTHERWISE STATED ALL DIMENSIONS IN INCHES (IMP)		
DR. JUS 5-2-12		
CK.		

- NOTES:
1. THE INSTALLATION SHALL COMPLY WITH THE RELEVANT REQUIREMENTS OF THE LATEST EDITION OF THE NATIONAL ELECTRICAL CODE® (ANSI/NFPA 70) AND THE CANADIAN ELECTRICAL CODE (C22.1) AS APPLICABLE.
 2. NO REVISION TO DRAWING WITHOUT PRIOR FM APPROVAL.
 3. CONTROL EQUIPMENT CONNECTED TO ASSOCIATED APPARATUS MUST NOT USE OR GENERATE MORE THAN 250 Vrms OR Vdc.
 4. ASSOCIATED APPARATUS MANUFACTURER'S INSTALLATION DRAWING MUST BE FOLLOWED WHEN INSTALLING THIS EQUIPMENT.
 5. DUST-TIGHT BOUNDARY SEAL MUST BE USED WHEN INSTALLED IN CLASS II AND CLASS III ENVIRONMENTS.
 6. WARNING - SUBSTITUTION OF COMPONENTS MAY IMPAIR INTRINSIC SAFETY.
 7. UNUSED OPENINGS MUST BE PROPERLY SEALED TO MAINTAIN ENCLOSURE ENVIRONMENTAL AND/OR HAZARDOUS LOCATION RATINGS.

7.2 FM US / FMC (Continued)

SPECIFIC CONDITIONS FOR USE:
 THE APPARATUS ENCLOSURE CONTAINS ALUMINUM AND IS CONSIDERED TO CONSTITUTE A POTENTIAL RISK OF IGNITION BY IMPACT OR FRICTION. CARE MUST BE TAKEN INTO ACCOUNT DURING INSTALLATION AND USE TO PREVENT IMPACT OR FRICTION.

CERTIFIED MODELS

Uab101cd00ef

a = TYPE P, L, OR C.
 b = FREQUENCY AND PHASING 0, 1, 2, 3
 c = ENTRIES 0, 2
 d = SURGE/NOISE SUPPRESSION 0, 1
 e = SENSING ELEMENT: R00, R01, R02, R03, R04, R05, 251, 252, 253, 254, 255, 256, 257, 258, 260, 261, 262, 301, 302, 303, 304, 305, 306, 307, 308, 309, 310, 311, 312, 313, 314, 315, 316, 317, 318, 319, 320, 321, 322, 323, 324, 325, 326, 327, 328, 329, 330, 331, 332, 333, 334, 335, 501, 502, 503, 504, 505, 506, 507, 508, 509, 510, 511, 512, 513, 601, 603, 604, 605, 606, 6-7, 608, 609, 610, 611, 613, 703, 705, 706, 708, 709, 713, 714, 715, 722, 722, ZZZ*
 f = 24 CHARACTER NUMBERING SYSTEM THAT DOES NOT AFFECT SAFETY

*ZZZ = SPECIAL SENSING ELEMENT
 700- ANY 7 DIGIT NUMERIC COMBINATION

NOTES:

1. MAXIMUM PROCESS TEMPERATURE 290°C
2. MAXIMUM SENSOR CAPACITANCE < 1uF
3. MAXIMUM INSERTION LENGTH RIGID SENSOR 30 FEET (9.144 METERS)
4. MAXIMUM INSERTION LENGTH FLEXIBLE SENSOR 2000 FEET (609.6 METERS)
5. SENSING ELEMENT ENCLOSURE IP66 (IP RATING DOES NOT APPLY TO SPECIAL SENSORS SUPPLIED WITHOUT A 285- SERIES SENSING ELEMENT ENCLOSURE).

CERTIFIED		by _____		COPYRIGHT 2012				FM/FMC CONTROL DRAWING FOR UNIVERSAL IV (INTEGRAL) IS ENTRY INSTALLATION		ISS. OF 16	
PO #		ENG		AMETEK DREXELBROOK						SHT. 6 OF 16	
USER	3 5-11-107 <i>Sif</i>	SCALE	NONE				420-0004-412-CD	ISS. OF 16		3	
	2 5-11-107 SGA	UNLESS OTHERWISE STATED ALL DIMENSIONS IN INCHES (MM)									
	1 5-11-107 SGA	DATE	5-20-11	DR.	JUS 5-2-12						
DE #		ISS. EDO/DSR NO.	APP'D	DATE	CK.						

215-674-1234
 205 KEITH VALLEY RD
 HORSHAM, PA 19044-9986
 FAX 215-674-2731

7.2 FM US / FMC (Continued)

NO. 420-0004-412-CD

SHT 7 OF 16

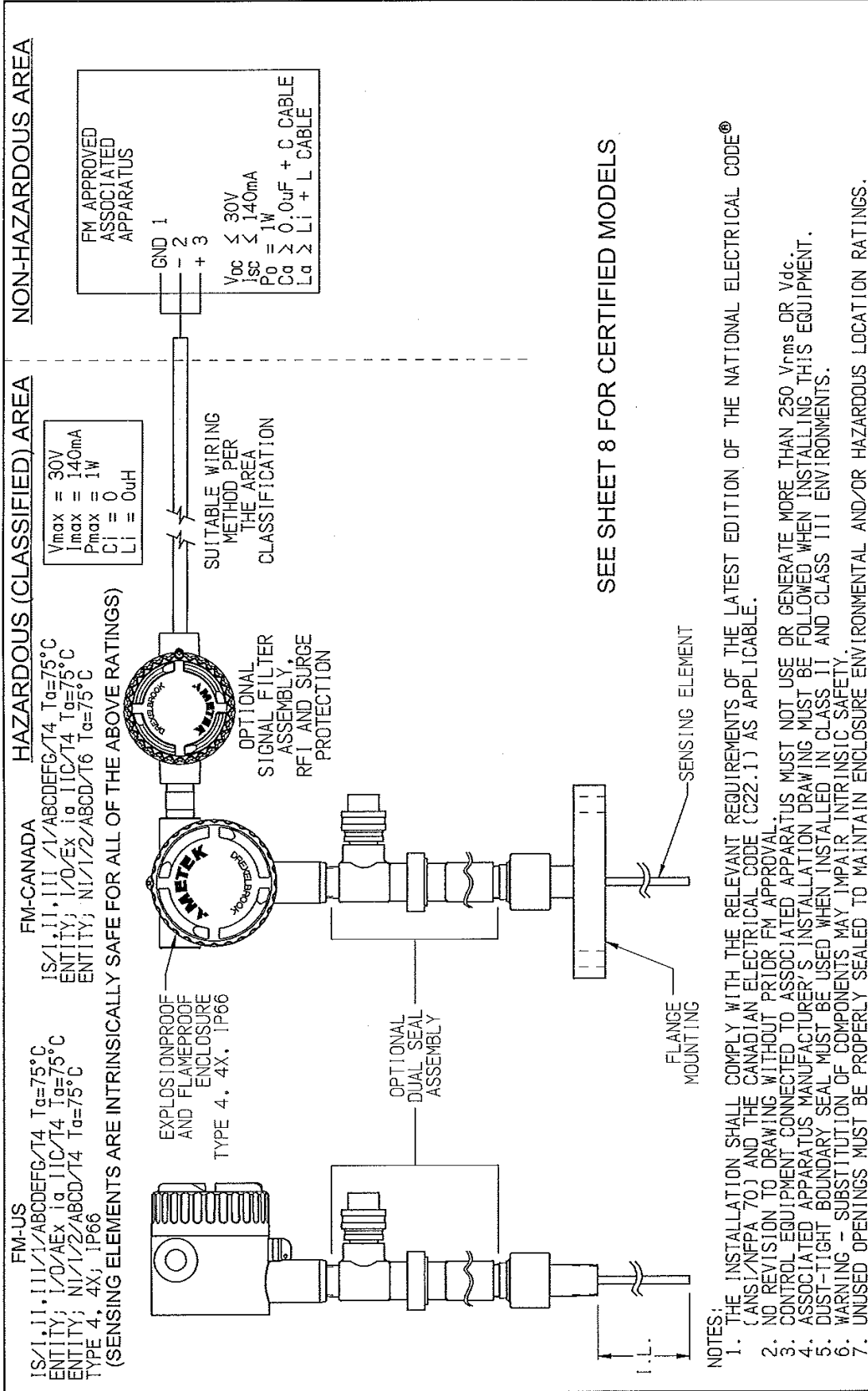

SEE SHEET 8 FOR CERTIFIED MODELS

- NOTES:
1. THE INSTALLATION SHALL COMPLY WITH THE RELEVANT REQUIREMENTS OF THE LATEST EDITION OF THE NATIONAL ELECTRICAL CODE® (ANSI/NFPA 70) AND THE CANADIAN ELECTRICAL CODE (C22.1) AS APPLICABLE.
 2. NO REVISION TO DRAWING WITHOUT PRIOR FM APPROVAL.
 3. CONTROL EQUIPMENT CONNECTED TO ASSOCIATED APPARATUS MUST NOT USE OR GENERATE MORE THAN 250 Vrms OR Vdc.
 4. ASSOCIATED APPARATUS MANUFACTURER'S INSTALLATION DRAWING MUST BE FOLLOWED WHEN INSTALLING THIS EQUIPMENT.
 5. DUST-TIGHT BOUNDARY SEAL MUST BE USED WHEN INSTALLED IN CLASS II AND CLASS III ENVIRONMENTS.
 6. WARNING - SUBSTITUTION OF COMPONENTS MAY IMPAIR INTRINSIC SAFETY.
 7. UNUSED OPENINGS MUST BE PROPERLY SEALED TO MAINTAIN ENCLOSURE ENVIRONMENTAL AND/OR HAZARDOUS LOCATION RATINGS.

CERTIFIED		by _____		COPYRIGHT 2012	
PO #		AVETEK DREXELBROOK		215-874-1234	
ENG	3	5-11-107	SCALE NONE		215-874-1234
USER	2	5-11-107	UNLESS OTHERWISE STATED		FAX 215-874-2731
	1	5-11-107	ALL DIMENSIONS IN INCHES (4X)		
ISS	EDD/USR	NO.	APP'D	DATE	DR. J.S. 5-2-12
DE #				DATE	CK. _____



FM/FMC CONTROL DRAWING FOR UNIVERSAL IV (INTEGRAL) ENTITY INSTALLATION DUAL SEAL OPTION

SHT. 7 OF 16
ISS. 3
420-0004-412-CD

205 KEITH VALLEY RD
HORSHAW, PA 19044-9986

7.2 FM US / FMC (Continued)

NO. 420-0004-412-CD SHT 8 OF 16

SPECIFIC CONDITIONS FOR USE:
 THE APPARATUS ENCLOSURE CONTAINS ALUMINUM AND IS CONSIDERED TO
 CONSTITUTE A POTENTIAL RISK OF IGNITION BY IMPACT OR FRICTION. CARE
 MUST BE TAKEN INTO ACCOUNT DURING INSTALLATION AND USE TO PREVENT
 IMPACT OR FRICTION.

CERTIFIED MODELS

Uab101cd01ef

- a = TYPE P, L, OR C.
- b = FREQUENCY AND PHASING 0, 1, 2, 3
- c = ENTRIES 0, 2
- d = SURGE/NOISE SUPPRESSION 0, 1
- e = SENSING ELEMENT: 101, 102, 103, 104, 105, 106, 107, 108, 109, 110, 111,
 112, 113, 301, 302, 303, 304, 305, 306, 307, 308, 309,
 310, 311, 312, 313, 314, 315, 316, 317, 318, 319, 320,
 321, 322, 323, 324, 325, 326, 327, 328, 329, 330, 331,
 332, 333, 334, 335, 601, 603, 604, 605, 606, 607, 608,
 609, 610, 611, 613
- f = 24 CHARACTER NUMBERING SYSTEM THAT DOES NOT AFFECT SAFETY

CERTIFIED		by _____		COPYRIGHT 2012		AMETEK DREXELBROOK		FM/FMC CONTROL DRAWING FOR UNIVERSAL IV (INTEGRAL) IS ENTITY INSTALLATION DUAL SEAL OPTION		
PO # _____	5-11-107	54	5-3-10	SCALE NONE	ALL DIMENSIONS IN INCHES (UN)	205 KEITH VALLEY RD HOBBSHAVEN, PA 19044-9986		215-674-1234 FAX 215-674-2731		
ENG _____	5-11-107	SGA	4-9-12	DR. J.S. 5-2-12	CK. _____	215-674-1234 FAX 215-674-2731		420-0004-412-CD		
USER _____	5-11-107	SGA	5-20-11			ISS. _____		SHT. 8 OF 16		
DE # _____	ISS. EDD/DSR NO. APP' D	DATE					CF 16		3	

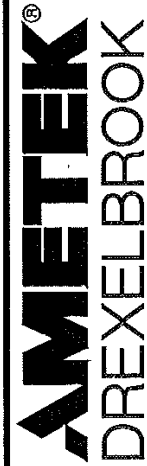

7.2 FM US / FMC (Continued)

No. 420-0004-412-CD SHT 9 OF 16

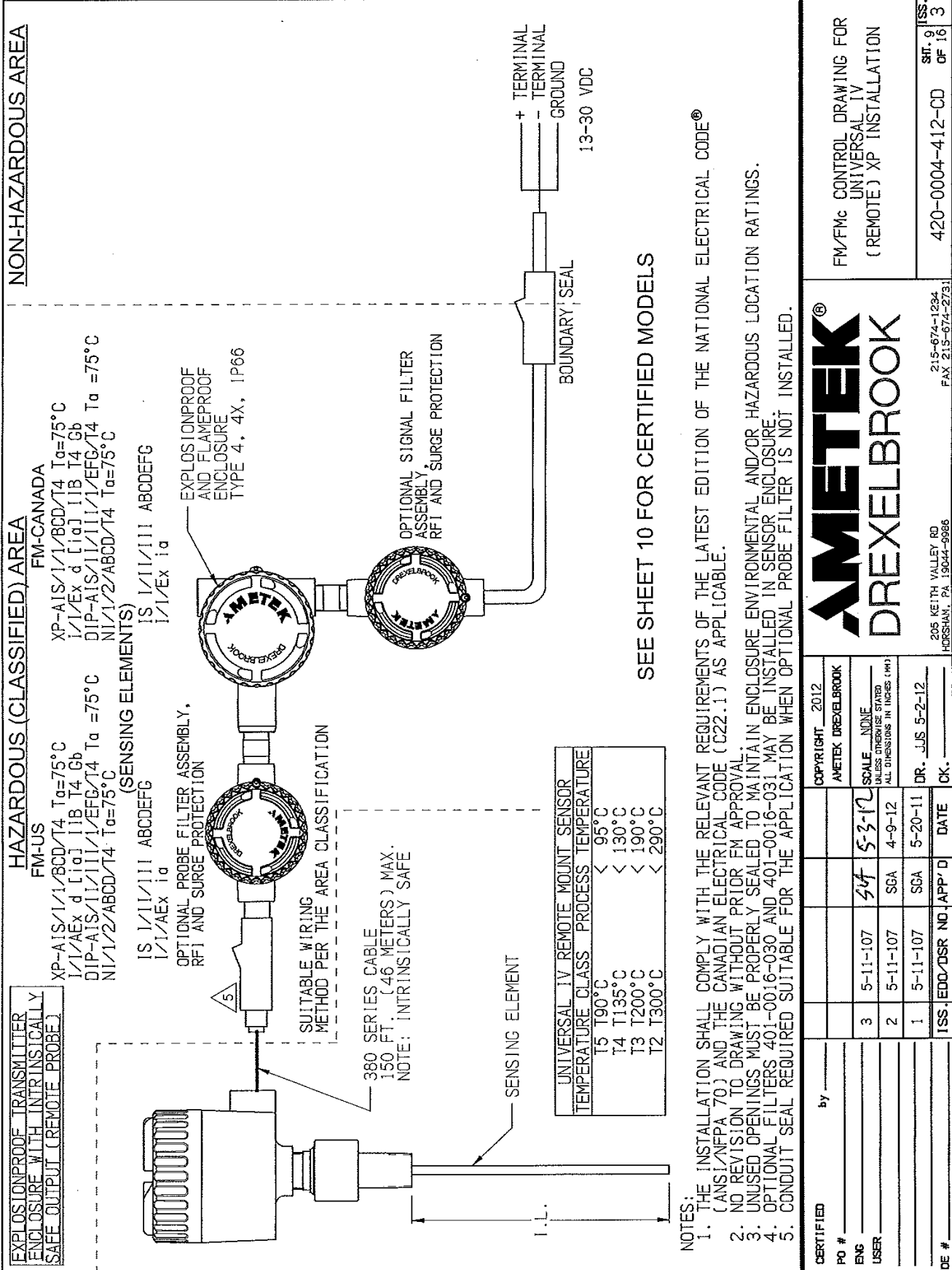

SEE SHEET 10 FOR CERTIFIED MODELS

- NOTES:
1. THE INSTALLATION SHALL COMPLY WITH THE RELEVANT REQUIREMENTS OF THE LATEST EDITION OF THE NATIONAL ELECTRICAL CODE® (CAN./NFPA 70) AND THE CANADIAN ELECTRICAL CODE (C22.1) AS APPLICABLE.
 2. NO REVISION TO DRAWING WITHOUT PRIOR FM APPROVAL.
 3. UNUSED OPENINGS MUST BE PROPERLY SEALED TO MAINTAIN ENCLOSURE ENVIRONMENTAL AND/OR HAZARDOUS LOCATION RATINGS.
 4. OPTIONAL FILTERS 401-0016-030 AND 401-0016-031 MAY BE INSTALLED IN SENSOR ENCLOSURE.
 5. CONDUIT SEAL REQUIRED SUITABLE FOR THE APPLICATION WHEN OPTIONAL PROBE FILTER IS NOT INSTALLED.

CERTIFIED	by	COPYRIGHT 2012	AMETEK DREXELBROOK
PO #		SCALE	5-3-12
ENG	5-11-107	UNLESS OTHERWISE STATED ALL DIMENSIONS IN INCHES (MM)	
USER	5-11-107	DR.	JUS 5-2-12
ISS. EDO/DSR NO./APP'D	5-11-107	DATE	OK
DE #			

205 KEITH VALLEY RD
MORRISVILLE, PA 19044-9886
215-674-1284
FAX 215-674-2731

FM/FMC CONTROL DRAWING FOR
UNIVERSAL IV
(REMOTE) XP INSTALLATION

420-0004-412-CD

SHT. 9 OF 16

7.2 FM US / FMC (Continued)

NO. 420-0004-412-CD SHT 10 OF 16

SPECIFIC CONDITIONS FOR USE:
 THE APPARATUS ENCLOSURE CONTAINS ALUMINUM AND IS CONSIDERED TO
 CONSTITUTE A POTENTIAL RISK OF IGNITION BY IMPACT OR FRICTION. CARE
 MUST BE TAKEN INTO ACCOUNT DURING INSTALLATION AND USE TO PREVENT
 IMPACT OR FRICTION.

CERTIFIED MODELS

Uab102cde0fg

- a = TYPE P, L, OR C.
- b = FREQUENCY AND PHASING 0, 1, 2, 3
- c = ENTRIES 0, 2
- d = SURGE/NOISE SUPPRESSION 0, 1, 2, 3, 4, 5, 6, 7, 8, 9, A, B, C, D, E, F, G, H, J, K, L, M, N, P, R, S, Z
- e = CABLE OPTIONS 1, 2, 3, 4, 5, 6, 7, 8, 9, A, B, C, D, E, F, G, H, J, K, L, M, N, P, R, S, Z
- f = SENSING ELEMENT: 109, 108, 107, 106, 105, 104, 103, 102, 101, 309, 308, 307, 306, 305, 304, 303, 302, 301, 319, 318, 317, 316, 315, 314, 313, 312, 311, 310, 322, 321, 320, 319, 318, 317, 316, 315, 314, 323, 324, 325, 326, 327, 328, 329, 330, 331, 332, 333, 334, 335, 501, 502, 503, 504, 505, 506, 507, 508, 509, 510, 513, 601, 603, 604, 605, 606, 607, 608, 609, 610, 611, 612, 613, 701, 702, 703, 704, 705, 706, 707, 708, 709, 710, 711, 712, 713, 714, 715, 716, 717, 718, 719, 720, 721, 722, 723, 724, 725, 726, 727, 728, 729, 730, 731, 732, 735, 736, 737, 738, 739, 740, 741, 742, 743, 744, 745, 746, 747, 748, 749, 750, 751, 752, ZZZ
- g = 24 CHARACTER NUMBERING SYSTEM THAT DOES NOT AFFECT SAFETY

* ZZZ = SPECIAL SENSING ELEMENT
 700- ANY 7 DIGIT NUMERIC COMBINATION

NOTES:

1. MAXIMUM PROCESS TEMPERATURE 290°C
2. MAXIMUM SENSOR CAPACITANCE < 1uF
3. MAXIMUM INSERTION LENGTH RIGID SENSOR 30 FEET (9.144 METERS)
4. MAXIMUM INSERTION LENGTH FLEXIBLE SENSOR 2000 FEET (609.6 METERS)
5. SENSING ELEMENT ENCLOSURE IP66 (IP RATING DOES NOT APPLY TO SPECIAL SENSORS SUPPLIED WITHOUT A 285- SERIES SENSING ELEMENT ENCLOSURE).

CERTIFIED	by	COPYRIGHT 2012	FM/FMC CONTROL DRAWING FOR UNIVERSAL IV (REMOTE) XP INSTALLATION
PO #		AMETEK DREXELBROOK	
ENG	SA 5-3-11	SCALE NONE	
USER	SSA 4-9-12	UNLESS OTHERWISE STATED ALL DIMENSIONS IN INCHES (IN)	
ISS. EDD/DSR NO.	SSA 5-20-11	DR. J.S 5-2-12	420-0004-412-CD
APP' D		CK.	SHT-10 OF 16
DATE			DF 16
DE #			3



205 KETH VALLEY RD
 HORSHPAN, PA 19044-9988
 215-874-1234
 FAX 215-874-2731

7.2 FM US / FMC (Continued)

NO. 420-0004-412-CD SHEET 11 OF 16

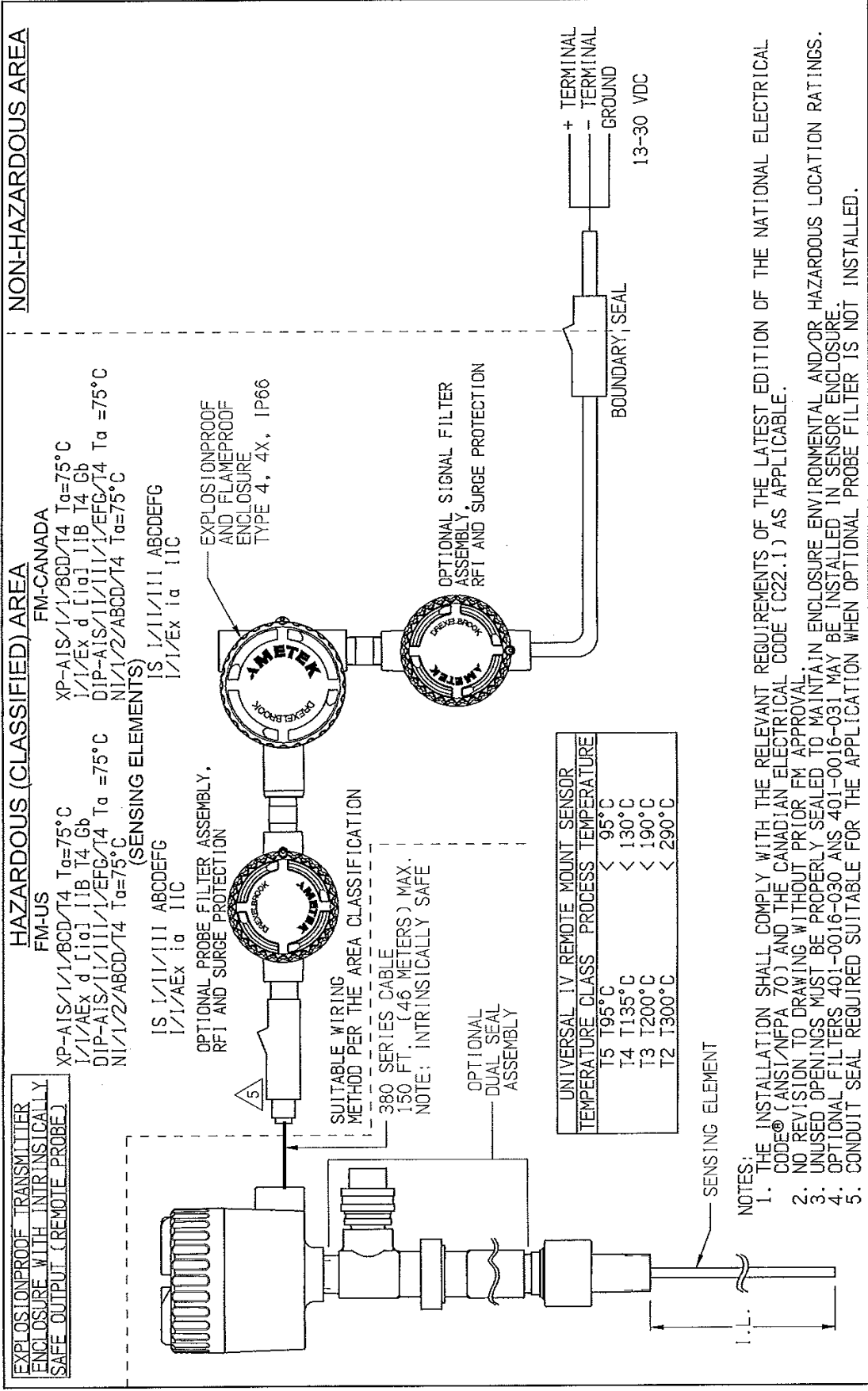

EXPLOSIONPROOF TRANSMITTER ENCLOSURE WITH INTRINSICALLY SAFE OUTPUT (REMOTE PROBE)

HAZARDOUS (CLASSIFIED) AREA
 FM-US
 XP-AIS/1/1/BCD/T4 Ta=75°C
 1/1/AEx d Iia IIB T4 Gb
 DIP-AIS/1/1/1/1/EEG/T4 Ta=75°C
 NI/1/2/ABCD/T4 Ta=75°C
 (SENSING ELEMENTS)
 IS 1/1/1/1/1 ABCDEFG
 1/1/AEx ia IIC

NON-HAZARDOUS AREA
 FM-CANADA
 XP-AIS/1/1/BCD/T4 Ta=75°C
 1/1/AEx d Iia IIB T4 Gb
 DIP-AIS/1/1/1/1/EEG/T4 Ta=75°C
 NI/1/2/ABCD/T4 Ta=75°C
 (SENSING ELEMENTS)
 IS 1/1/1/1/1 ABCDEFG
 1/1/AEx ia IIC

UNIVERSAL IV REMOTE MOUNT SENSOR

TEMPERATURE CLASS	PROCESS TEMPERATURE
T5	T95°C < 95°C
T4	T135°C < 130°C
T3	T200°C < 190°C
T2	T300°C < 290°C

NOTES:

1. THE INSTALLATION SHALL COMPLY WITH THE RELEVANT REQUIREMENTS OF THE LATEST EDITION OF THE NATIONAL ELECTRICAL CODE® (ANSI/NFPA 70) AND THE CANADIAN ELECTRICAL CODE (C22.1) AS APPLICABLE.
2. NO REVISION TO DRAWING WITHOUT PRIOR FM APPROVAL.
3. UNUSED OPENINGS MUST BE PROPERLY SEALED TO MAINTAIN ENCLOSURE ENVIRONMENTAL AND/OR HAZARDOUS LOCATION RATINGS.
4. OPTIONAL FILTERS 401-0016-030 ANS 401-0016-031 MAY BE INSTALLED IN SENSOR ENCLOSURE.
5. CONDUIT SEAL REQUIRED SUITABLE FOR THE APPLICATION WHEN OPTIONAL PROBE FILTER IS NOT INSTALLED.

AMETEK® DREXELBROOK

205 KETH VALLEY RD
 HORSHAM, PA 19044-9986
 215-674-1234
 FAX 215-674-2731

ISS. DATE APP'D DATE
 3 5-11-107 SGA 4-9-12
 2 5-11-107 SGA 5-20-11
 1 5-11-107 SGA 5-20-11

DR. JUS 5-2-12
 CK. _____

FM/FMC CONTROL DRAWING FOR
 UNIVERSAL IV
 (REMOTE) XP INSTALLATION
 DUAL SEAL OPTION

420-0004-412-CD SHEET 11 OF 16

7.2 FM US / FMC (Continued)

NO. 420-0004-412-CD SHT 12 OF 16

SPECIFIC CONDITIONS FOR USE:
 THE APPARATUS ENCLOSURE CONTAINS ALUMINUM AND IS CONSIDERED TO
 CONSTITUTE A POTENTIAL RISK OF IGNITION BY IMPACT OR FRICTION. CARE
 MUST BE TAKEN INTO ACCOUNT DURING INSTALLATION AND USE TO PREVENT
 IMPACT OR FRICTION.

CERTIFIED MODELS

Uab102cde1fg

- a = TYPE P, L, OR C.
- b = FREQUENCY AND PHASING 0, 1, 2, 3
- c = ENTRIES 0, 2
- d = SURGE/NOISE SUPPRESSION 0, 2, 3, 4, 5, 6, 7, D
- e = CABLE OPTIONS: 1, 2, 3, 4, 5, 6, 7, 8, 9, A, C, B, D, E, F, G, H, J, K, L, M, N, P, R, S, Z
- f = SENSING ELEMENT: 101, 102, 103, 104, 105, 106, 107, 108, 109, 110, 111, 112, 113, 301, 302, 303, 304, 305, 306, 307, 308, 309, 310, 311, 312, 313, 314, 315, 316, 317, 318, 319, 320, 321, 322, 323, 324, 325, 326, 327, 328, 329, 330, 331, 332, 333, 334, 335, 601, 603, 604, 605, 606, 607, 608, 609, 610, 611, 612, 613
- g = 24 CHARACTER NUMBERING SYSTEM THAT DOES NOT AFFECT SAFETY

CERTIFIED		by _____		COPYRIGHT 2012		AMETEK DREXELBROOK	
PO #							
ENG		5A	5-3-17	SCALE	NONE	UNLESS OTHERWISE STATED	
USER		SGA	4-9-12	ALL DIMENSIONS IN INCHES (IN)			
		SGA	5-20-11	DR.	JUS 5-2-12		
ISS #				CK.			
DE #							

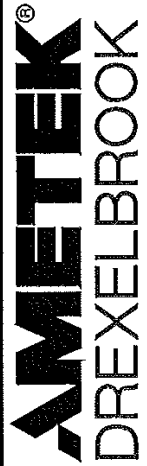

205 KEITH VALLEY RD
 HORSHAM, PA 19044-9986
 215-674-1234
 FAX 215-674-2731

FM/FMC CONTROL DRAWING FOR
 UNIVERSAL IV
 (REMOTE) XP INSTALLATION
 DUAL SEAL OPTION

420-0004-412-CD SHT 12 OF 16

7.2 FM US / FMC (Continued)

No. 420-0004-412-CD

SHT 13 OF 16

NON-HAZARDOUS AREA

HAZARDOUS (CLASSIFIED) AREA

FM-CANADA

FM-US

IS/1, II, III/1/ABCDEF/T4 Ta=75°C
 ENTITY; I/O/Ex ia IIC T4 Ta=75°C
 ENTITY; NI/1/2/ABCD/T4 Ta=75°C

IS/1, II, III/1/ABCDEF/T4 Ta=75°C
 ENTITY; I/O/Ex ia IIC T4 Ta=75°C
 ENTITY; NI/1/2/ABCD/T4 Ta=75°C

IS/1, II, III/1/ABCDEF/T4 Ta=75°C
 ENTITY; I/O/Ex ia IIC T4 Ta=75°C
 ENTITY; NI/1/2/ABCD/T4 Ta=75°C

V_{max} = 30V
 I_{max} = 140mA
 P_{max} = 1W
 C_i = 0
 L_i = 0uH

(SENSING ELEMENTS ARE INTRINSICALLY SAFE FOR ALL OF THE ABOVE RATINGS)

OPTIONAL PROBE FILTER ASSEMBLY,
 RFI AND SURGE PROTECTION

EXPLOSIONPROOF
 AND FLAMEPROOF
 ENCLOSURE
 TYPE 4, 4X, IP66

SUITABLE WIRING
 METHOD PER THE AREA CLASSIFICATION

380 SERIES CABLE
 150 FT. (46 METERS) MAX.
 NOTE: INTRINSICALLY SAFE

OPTIONAL SIGNAL FILTER
 ASSEMBLY,
 RFI AND SURGE PROTECTION

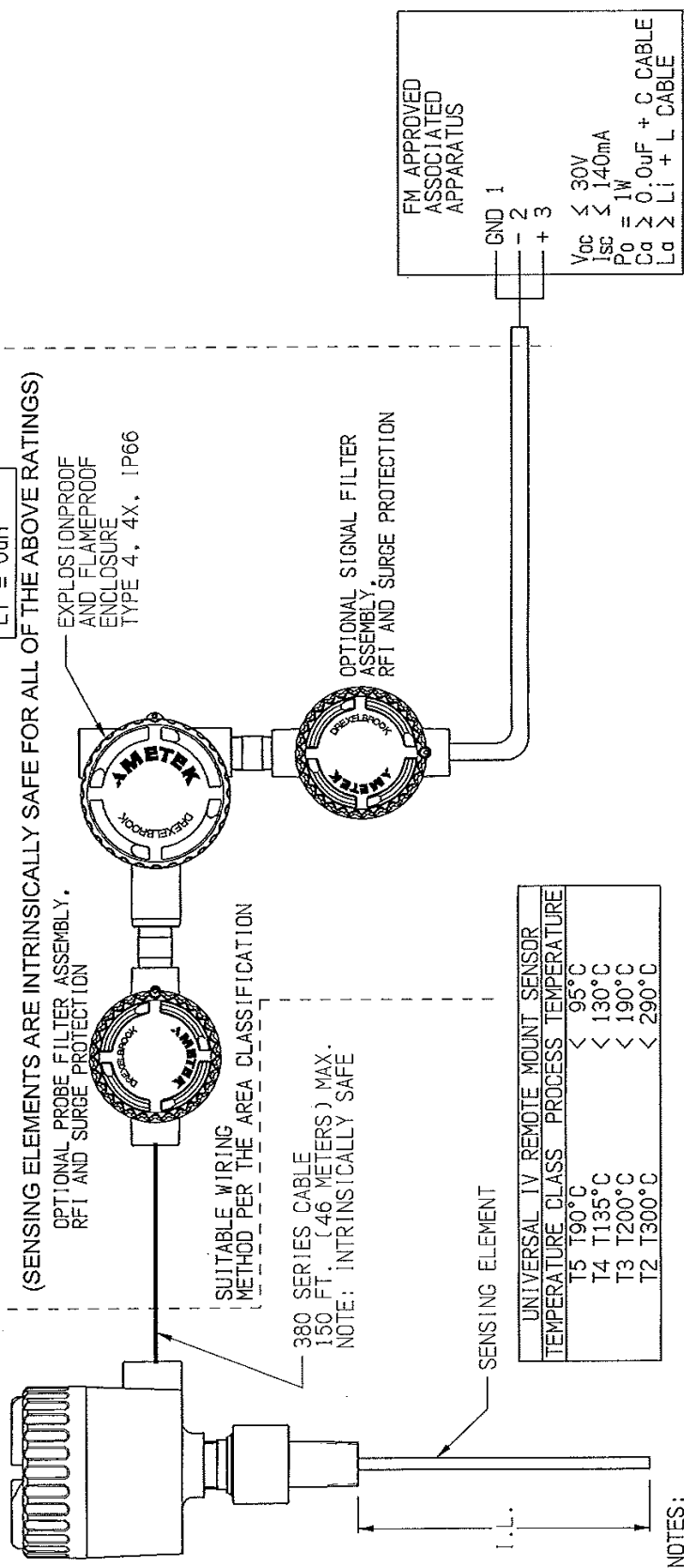

NOTES:
 1. THE INSTALLATION SHALL COMPLY WITH THE RELEVANT REQUIREMENTS OF THE LATEST EDITION OF THE NATIONAL ELECTRICAL CODE® (ANSI/NFPA 70) AND THE CANADIAN ELECTRICAL CODE (C22.1) AS APPLICABLE.
 2. NO REVISION TO DRAWING WITHOUT PRIOR FM APPROVAL.
 3. CONTROL EQUIPMENT CONNECTED TO ASSOCIATED APPARATUS MUST NOT USE OR GENERATE MORE THAN 250 V_{rms} OR V_{dc}.
 4. ASSOCIATED APPARATUS MANUFACTURER'S INSTALLATION DRAWING MUST BE FOLLOWED WHEN INSTALLING THIS EQUIPMENT.
 5. DUST-TIGHT CONDUIT SEAL MUST BE USED WHEN INSTALLED IN CLASS II AND CLASS III ENVIRONMENTS.
 6. WARNING - SUBSTITUTION OF COMPONENTS MAY IMPAIR INTRINSIC SAFETY.
 7. UNUSED OPENINGS MUST BE PROPERLY SEALED TO MAINTAIN ENCLOSURE ENVIRONMENTAL AND/OR HAZARDOUS LOCATION RATINGS.
 8. OPTIONAL FILTERS 401-0016-030 AND 401-0016-031 MAY BE INSTALLED IN SENSOR ENCLOSURE.

FM/FMC CONTROL DRAWING FOR
 UNIVERSAL IV (REMOTE)
 IS ENTITY INSTALLATION

420-0004-412-CD

SHT. 13 OF 16



205 KETH VALLEY RD.
 HORSHAM, PA 19044-9586

215-674-1234
 FAX 215-674-2731

CERTIFIED	by		
PO #			
ENG			
USER			
ISS. EDD/DSR NO.	APP'D	DATE	OK.
3	5-11-107		
2	5-11-107	SGA	4-9-12
1	5-11-107	SGA	5-20-11
DR.	JUS	5-2-12	
COPYRIGHT	2012		
AMETEK DREXELBROOK			
SCALE	NONE		
UNLESS OTHERWISE STATED ALL DIMENSIONS IN INCHES (IN)			

7.2 FM US / FMC (Continued)

NO. 420-0004-412-CD SHT 14 OF 16

SPECIFIC CONDITIONS FOR USE:
 THE APPARATUS ENCLOSURE CONTAINS ALUMINUM AND IS CONSIDERED TO
 CONSTITUTE A POTENTIAL RISK OF IGNITION BY IMPACT OR FRICTION. CARE
 MUST BE TAKEN INTO ACCOUNT DURING INSTALLATION AND USE TO PREVENT
 IMPACT OR FRICTION.

CERTIFIED MODELS

Uab101cde0fg

a = TYPE P, L, OR C
 b = FREQUENCY AND PHASING 0, 1, 2, 3
 c = ENTRIES 0, 2
 d = SURGE/NOISE SUPPRESSION 0, 1, 2, 3, 4, 5, 6, 7, 8, 9, A, B, C, D, E, F, G, H, J, K, L, M, N, P, R, S, Z
 e = CABLE OPTIONS 1, 2, 3, 4, 5, 6, 7, 8, 9, A, B, C, D, E, F, G, H, J, K, L, M, N, P, R, S, Z
 f = SENSING ELEMENT: R09, 000, 101, 102, 103, 104, 105, 106, 107, 108, 109,
 110, 111, 112, 113, 301, 302, 303, 304, 305, 306, 307, 308, 309,
 310, 311, 312, 313, 314, 315, 316, 317, 318, 319, 320, 321, 322,
 323, 324, 325, 326, 327, 328, 329, 330, 331, 332, 333, 334, 335,
 501, 502, 503, 504, 505, 506, 507, 508, 509, 510, 513, 601, 603,
 604, 605, 606, 607, 608, 609, 610, 611, 612, 613, 701, 702, 703,
 704, 705, 706, 707, 708, 709, 710, 711, 712, 713, 714, 715, 716,
 717, 718, 719, 720, 721, 722, 723, 724, 725, 726, 727, 728, 729,
 730, 731, 732, 735, 736, 737, 738, 739, 740, 741, 742, 743, 744,
 745, 746, 747, 748, 749, 750, 751, 752, ZZZ*
 g = 24 CHARACTER NUMBERING SYSTEM THAT DOES NOT AFFECT SAFETY

*ZZZ = SPECIAL SENSING ELEMENT
 700- ANY 7 DIGIT NUMERIC COMBINATION

NOTES:

1. MAXIMUM PROCESS TEMPERATURE 290°C
2. MAXIMUM SENSOR CAPACITANCE < 1uF
3. MAXIMUM INSERTION LENGTH RIGID SENSOR 30 FEET (9.144 METERS)
4. MAXIMUM INSERTION LENGTH FLEXIBLE SENSOR 2000 FEET (609.6 METERS)
5. SENSING ELEMENT ENCLOSURE IP66 (IP RATING DOES NOT APPLY TO SPECIAL SENSORS SUPPLIED WITHOUT A 285- SERIES SENSING ELEMENT ENCLOSURE).

CERTIFIED		COPYRIGHT 2012		FM/FMC CONTROL DRAWING FOR UNIVERSAL IV (REMOTE) IS ENTITY INSTALLATION	
PO #		AMETEK DREXELBROOK		420-0004-412-CD	
ENG		SCALE NONE		SHT. 14 OF 16	
USER		UNLESS OTHERWISE STATED ALL DIMENSIONS IN INCHES (MM)		CF 16	
ISS. EDD./DSR NO.	3	5-11-107	5-3-12	420-0004-412-CD	
APP'D	2	5-11-107	SGA 4-9-12	SHT. 14 OF 16	
DATE	1	5-11-107	SGA 5-20-11	420-0004-412-CD	
DE #			DR. J.S. 5-2-12	SHT. 14 OF 16	
			CK.	CF 16	



205 KEITH VALLEY RD
 HORSHAM, PA 19044-9988
 215-674-1234
 FAX 215-672-2731

7.2 FM US / FMC (Continued)

NO. 420-0004-412-CD

SHT 15 OF 16

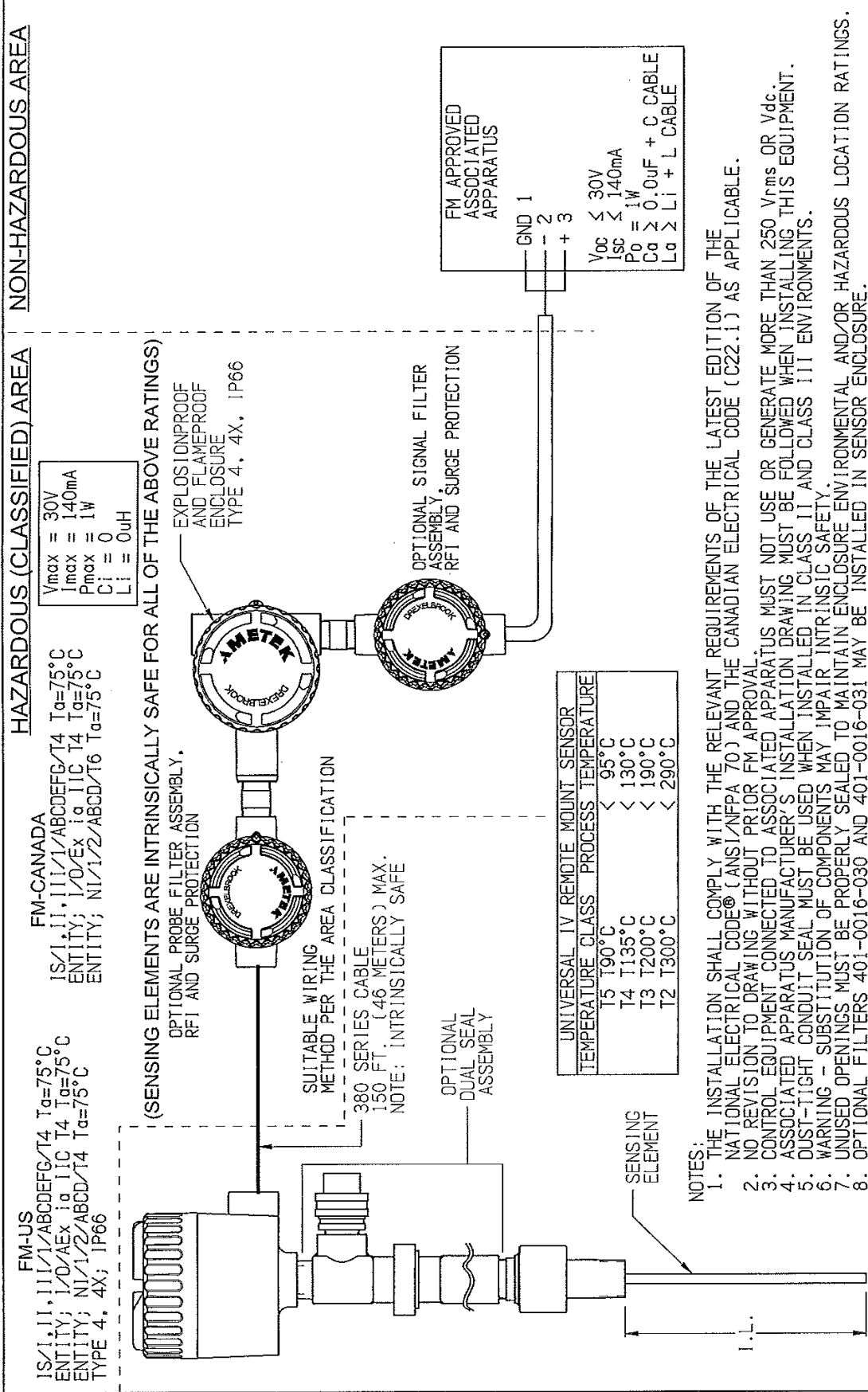

FM/FMC CONTROL DRAWING FOR UNIVERSAL IV (REMOTE) IS ENTITY INSTALLATION DUAL SEAL OPTION

420-0004-412-CD

SHT 15 OF 16

AMETEK®
DREXELBROOK

205 KETH VALLEY RD.
HURSHAM, PA 19044-5986

215-674-1234
FAX: 215-674-2731

CERTIFIED	by				
PO #					
ENG					
USER					
ISS. EDD/DSR NO.	APP'D	DATE			
3		5-11-107			
2		5-11-107	SGA	4-9-12	
1		5-11-107	SGA	5-20-11	
ISS.	EDD/DSR NO.	APP'D	DATE		

- NOTES:
1. THE INSTALLATION SHALL COMPLY WITH THE RELEVANT REQUIREMENTS OF THE LATEST EDITION OF THE NATIONAL ELECTRICAL CODE® (ANSI/NFPA 70) AND THE CANADIAN ELECTRICAL CODE (C22.1) AS APPLICABLE.
 2. NO REVISION TO DRAWING WITHOUT PRIOR FM APPROVAL.
 3. CONTROL EQUIPMENT CONNECTED TO ASSOCIATED APPARATUS MUST NOT USE OR GENERATE MORE THAN 250 Vrms OR Vdc.
 4. ASSOCIATED APPARATUS MANUFACTURER'S INSTALLATION DRAWING MUST BE FOLLOWED WHEN INSTALLING THIS EQUIPMENT.
 5. DUST-TIGHT CONDUIT SEAL MUST BE USED WHEN INSTALLED IN CLASS II AND CLASS III ENVIRONMENTS.
 6. WARNING - SUBSTITUTION OF COMPONENTS MAY IMPAIR INTRINSIC SAFETY.
 7. UNUSED OPENINGS MUST BE PROPERLY SEALED TO MAINTAIN ENCLOSURE ENVIRONMENTAL AND/OR HAZARDOUS LOCATION RATINGS.
 8. OPTIONAL FILTERS 401-0016-030 AND 401-0016-031 MAY BE INSTALLED IN SENSOR ENCLOSURE.

7.2 FM US / FMC (Continued)

NO. 420-0004-412-CD SHT 16 OF 16

SPECIFIC CONDITIONS FOR USE:
 THE APPARATUS ENCLOSURE CONTAINS ALUMINUM AND IS CONSIDERED TO
 CONSTITUTE A POTENTIAL RISK OF IGNITION BY IMPACT OR FRICTION. CARE
 MUST BE TAKEN INTO ACCOUNT DURING INSTALLATION AND USE TO PREVENT
 IMPACT OR FRICTION.

CERTIFIED MODELS

Uab101cde1fg

- a = TYPE P, L, OR C.
- b = FREQUENCY AND PHASING 0, 1, 2, 3
- c = ENTRIES 0, 2
- d = SURGE/NOISE SUPPRESSION 0, 1, 2, 3, 4, 5, 6, 7, 8, 9, A, C, B, D, E, F, G, H, J, K, L, M, N, P, R, S, Z
- e = CABLE OPTIONS: 101, 102, 103, 104, 105, 106, 107, 108, 109, 110, 111, 112, 113, 301, 302, 303, 304, 305, 306, 307, 308, 309, 310, 311, 312, 313, 314, 315, 316, 317, 318, 319, 320, 321, 322, 323, 324, 325, 326, 327, 328, 329, 330, 331, 332, 333, 334, 335, 601, 603, 604, 605, 606, 607, 608, 609, 610, 611, 612, 613
- f = SENSING ELEMENT:
- g = 24 CHARACTER NUMBERING SYSTEM THAT DOES NOT AFFECT SAFETY

CERTIFIED		COPYRIGHT 2012		FM/FMC CONTROL DRAWING FOR UNIVERSAL IV (REMOTE) IS ENTITY INSTALLATION DUAL SEAL OPTION	
PO #	by	AMETEK DREXELBROOK	215-674-1294		SHT. 16 OF 16
ENG	5 of 5-3-12	SCALE NONE	215-674-1294		OF 16
USER	SGA 4-9-12	UNLESS OTHERWISE STATED ALL DIMENSIONS IN INCHES (1:1)	FAX 215-674-2731		3
ISS	5-11-107	DR. J.S. 5-2-12	285 KEITH VALLEY RD		420-0004-412-CD
EDD/DSR NO.	5-11-107	DATE	HORSHAM, PA 19044-5966		
APP'D	5-20-11	CK.			
DE #					

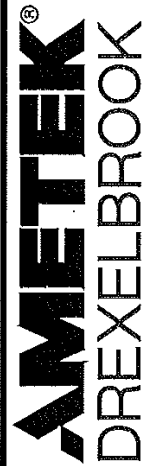

Section 8: Approval Certificates

8.1 FM US Approval Certificate

420-0004-429		Sht. 1 of 5	APP'D BY SGA
ISSUE	EDO NO.	APP'D	DATE
1	5-12-106	SGA	5/17/12
2	10-12-106	SGA	10/14/12



FM Approvals
1151 Boston Providence Turnpike
P.O. Box 9102 Norwood, MA 02062 USA
T: 781 762 4300 F: 781-762-9375 www.fmapprovals.com

CERTIFICATE OF COMPLIANCE

HAZARDOUS (CLASSIFIED) LOCATION ELECTRICAL EQUIPMENT

This certificate is issued for the following equipment:

Uab102cd00-e-f. Universal IV - Integral

XP-IS / I / I / CD / T4 Ta = 75 °C – 420-0004-424-CD; System
I / I / AEx d ia IIB T4 Ta = 75 °C – 420-0004-424-CD; System
DIP-IS / II, III / I / EFG / T4 Ta = 75 °C – 420-0004-424-CD; System
NI / I / 2 / ABCD / T4 Ta = 75 °C

Type 4, 4X; IP66

- a = Type P, L, or C.
- b = Frequency and Phasing 0, 1, 2, or 3.
- c = Entries 0 or 2.
- d = Surge/Noise suppression 0 or 1.
- e = Sensing element R111, R112, R113, R114, R115, 251, 252, 253, 254, 255, 256, 257, 258, 259, 260, 261, 262, 301, 302, 303, 304, 305, 306, 307, 308, 309, 310, 311, 312, 313, 314, 315, 316, 317, 318, 319, 320, 321, 322, 323, 324, 325, 326, 327, 502, 503, 504, 505, 506, 507, 508, 510, 511, or 512.
- f = 24 character numbering system not affecting safety.

Uab102cd01-e-f. Universal IV - Integral with Dual Seal

XP-IS / I / I / CD / T4 Ta = 75 °C – 420-0004-424-CD; System
I / I / AEx d ia IIB T4 Ta = 75 °C – 420-0004-424-CD; System
DIP-IS / II, III / I / EFG / T4 Ta = 75 °C
NI / I / 2 / ABCD / T4 Ta = 75 °C

Type 4, 4X; IP66

- a = Type P, L, or C.
- b = Frequency and Phasing 0, 1, 2, or 3.
- c = Entries 0 or 2.
- d = Surge/Noise suppression 0 or 1.
- e = Sensing element 101, 102, 103, 104, 105, 106, 107, 108, 109, 110, 111, 112, 113, 301, 302, 303, 304, 305, 306, 307, 308, 309, 310, 311, 312, 313, 314, 315, 316, 317, 318, 319, 320, 321, 322, 323, 324, 325, 326, 327.
- f = 24 character numbering system not affecting safety.

8.1 FM US Approval Certificate (Continued)

420-0004-429	Sht.	2	ISSUE
	of	5	



Uab101cd00-e-f. Universal IV - Integral

IS / I, II, III / 1 / ABCDEFG / T4 Ta = 75 °C – 420-0004-412-CD; Entity

I / 0 / AEx Ia IIC / T4 Ta = 75 °C – 420-0004-412-CD; Entity

NI / I / 2 / ABCD / T4 Ta = 75°C;

Type 4, 4X; IP66

Entity Parameters: Ui = 30 V, Ii = 140 mA, Pi = 1 W, Ci = 0, Li = 0

a = Type P, L, or C.

b = Frequency and Phasing 0, 1, 2, or 3.

c = Entries 0 or 2.

d = Surge/noise suppression 0 or 1.

e = Sensing element R00, R01, R02, R03, R04, R05, 251, 252, 253, 254, 255, 256, 257, 258, 259, 260, 261, 262, 301, 302, 303, 304, 305, 306, 307, 308, 309, 310, 311, 312, 313, 314, 315, 316, 317, 318, 319, 320, 321, 322, 323, 324, 325, 326, 327, 328, 329, 330, 331, 332, 333, 334, 335, 501, 502, 503, 504, 505, 506, 507, 508, 509, 510, 511, 512, 513, 601, 603604, 605, 606, 607, 608, 609, 610, 611, 613, 703, 705, 706, 708, 709, 713, 714, 715, 722, or any other 7 digit numeric combination maintaining the limits of 420-0004-412-CD.

f = 24 character numbering system not affecting safety.

Uab101cd01-e-f. Universal IV – Integral with Dual Seal

IS / I, II, III / 1 / ABCDEFG / T4 Ta = 75 °C – 420-0004-412-CD; Entity

I / 0 / AEx Ia IIC / T4 Ta = 75 °C – 420-0004-412-CD; Entity

NI / I / 2 / ABCD / T4 Ta = 75°C;

Type 4, 4X; IP66

Entity Parameters: Ui = 30 V, Ii = 140 mA, Pi = 1 W, Ci = 0, Li = 0

a = Type P, L, or C.

b = Frequency and Phasing 0, 1, 2, or 3.

c = Entries 0 or 2.

d = Surge/noise suppression 0 or 1.

e = Sensing element 101, 102, 103, 104, 105, 106, 107, 108, 109, 110, 111, 112, 113, 301, 302, 303, 304, 305, 306, 307, 308, 309, 310, 311, 312, 313, 314, 315, 316, 317, 318, 319, 320, 321, 322, 323, 324, 325, 326, 327, 328, 329, 330, 331, 332, 333, 334, 335, 601, 603, 604, 605, 606, 607, 608, 609, 610, 611, 613.

f = 24 character numbering system not affecting safety.

Uab102cde0-f-g. Universal IV - Remote

XP-AIS / I / 1 / CD / T4 Ta = 75 °C; – 420-0004-424-CD; System

I / 1 / AEx d [ja] IIB T4 Ta = 75 °C; – 420-0004-424-CD; System

DIP-AIS / II, III / 1 / EFG / T4 Ta = 75 °C; – 420-0004-424-CD; System

NI / I / 2 / ABCD / T4 Ta = 75 °C;

Type 4, 4X; IP66

a = Type P, L, or C.

b = Frequency and Phasing 0, 1, 2, or 3.

c = Entries 0 or 2.

d = Surge/Noise suppression 0, 1, 2, 3, 4, 5, 6, 7, or D

e = Cable options 1, 2, 3, 4, 5, 6, 7, 8, 9, A, B, C, D, E, F, G, H, J, K, L, M, N, P, R, S, or Z

f = Sensing element RO9, 000, 101, 102, 103, 104, 105, 106, 107, 108, 109, 110, 111, 112, 113, 301, 302, 303, 304, 305, 306, 307, 308, 309, 310, 311, 312, 313, 314, 315, 316, 317, 318, 319, 320, 321, 322, 323, 324, 325, 326, 327, 328, 329, 330, 331, 332, 333, 334, 335, 501, 502, 503, 504, 505, 506, 507, 508, 509, 510, 513, 601, 603, 604, 605, 606, 607, 608, 609, 607, 608, 609, 610, 611, 612, 613, 701, 702, 703, 704, 705, 706, 707, 708, 709, 710, 711, 712, 713, 714, 715, 716, 717, 718, 719, 720, 721, 722, 723, 724, 725, 726, 727, 728, 729, 730, 731, 732, 735, 736, 737, 738, 739, 740, 741, 742, 743, 744, 745, 746, 747, 748, 749, 750, 751, 752, or any other 7 digit numeric combination maintaining the limits of 420-0004-412-CD.

g = 24 character numbering system not affecting safety.

8.1 FM US Approval Certificate (Continued)

420-0004-429	Sht.	3	ISSUE
	of	5	

**Uab102cde1-f-g. Universal IV – Remote with Dual Seal**

XP-AIS / I / 1 / CD / T4 Ta = 75 °C – 420-0004-424-CD; System
 I / 1 / AEx d [ia] IIB T4 Ta = 75 °C – 420-0004-424-CD; System
 DIP-AIS / II, III / 1 / EFG / T4 Ta = 75 °C – 420-0004-424-CD; System
 NI / I / 2 / ABCD / T4 Ta = 75 °C;

Type 4, 4X; IP66

Entity Parameters: Ui = 30 V, Ii = 140 mA, Pi = 1 W, Ci = 0, Li = 0

- a = Type P, L, or C.
- b = Frequency and Phasing 0, 1, 2, or 3.
- c = Entries 0 or 2.
- d = Surge/Noise suppression 0, 1, 2, 3, 4, 5, 6, 7, or D.
- e = Cable options 1, 2, 3, 4, 5, 6, 7, 8, 9, A, B, C, D, E, F, G, H, J, K, L, M, N, P, R, S, or Z
- f = Sensing element 101, 102, 103, 104, 105, 106, 107, 108, 109, 110, 111, 112, 113, 301, 302, 303, 304, 305, 306, 307, 308, 309, 310, 311, 312, 313, 314, 315, 316, 317, 318, 319, 320, 321, 322, 323, 324, 325, 326, 327, 328, 329, 330, 331, 332, 333, 334, 335, 601, 603, 604, 605, 606, 607, 608, 609, 607, 608, 609, 610, 611, 612, or 613.
- g = 24 character numbering system not affecting safety.

Uab101cde0-f-g. Universal IV - Remote

IS / I, II, III / 1 / ABCDEFG / T4 Ta = 75 °C – 420-0004-412-CD; Entity
 I / 0 / AEx ia IIC / T4 Ta = 75 °C – 420-0004-412-CD ; Entity
 NI / I / 2 / ABCD / T4 Ta = 75 °C

Type 4, 4X; IP66

Entity Parameters: Ui = 30 V, Ii = 140 mA, Pi = 1 W, Ci = 0, Li = 0

- a = Type P, L, or C.
- b = Frequency and Phasing 0, 1, 2, or 3.
- c = Entries 0 or 2.
- d = Surge/Noise suppression 0, 1, 2, 3, 4, 5, 6, 7, or D.
- e = Cable options 1, 2, 3, 4, 5, 6, 7, 8, 9, A, B, C, D, E, F, G, H, J, K, L, M, N, P, R, S, Z.
- f = Sensing element RO9, 000, 101, 102, 103, 104, 105, 106, 107, 108, 109, 110, 111, 112, 113, 301, 302, 303, 304, 305, 306, 307, 308, 309, 310, 311, 312, 313, 314, 315, 316, 317, 318, 319, 320, 321, 322, 323, 324, 325, 326, 327, 328, 329, 330, 331, 332, 333, 334, 335, 501, 502, 503, 504, 505, 506, 507, 508, 509, 510, 513, 601, 603, 604, 605, 606, 607, 608, 609, 607, 608, 609, 610, 611, 612, 613, 701, 702, 703, 704, 705, 706, 707, 708, 709, 710, 711, 712, 713, 714, 715, 716, 717, 718, 719, 720, 721, 722, 723, 724, 725, 726, 727, 728, 729, 730, 731, 732, 735, 736, 737, 738, 739, 740, 741, 742, 743, 744, 745, 746, 747, 748, 749, 750, 751, 752, or any other 7 digit numeric combination maintaining the limits of 420-0004-412-CD.
- g = 24 character numbering system not affecting safety.

Special Conditions of Use:

1. In Zone 0 locations, care must be taken when installing the aluminium enclosure that even in the event of rare incidents, an ignition source due to impact or friction between the enclosure and iron / steel is excluded.

8.1 FM US Approval Certificate (Continued)

420-0004-429	Sht. 4	ISSUE
	of 5	2



Uab101cde1-f-g. Universal IV – Remote with Dual Seal

IS / I, II, III / 1 / ABCDEFG / T4 Ta = 75 °C – 420-0004-412-CD; Entity

I / 0 / AEx ia IIC / T4 Ta = 75°C – 420-0004-412-CD; Entity

NI / 1 / 2 / ABCD / T4 Ta = 75°C;

Type 4, 4X; IP66

Entity Parameters: Ui = 30 V, Ii = 140 mA, Pi = 1 W, Ci = 0, Li = 0

a = Type P, L, or C.

b = Frequency and Phasing 0, 1, 2, or 3.

c = Entries 0 or 2.

d = Surge/noise suppression 0, 1, 2, 3, 4, 5, 6, 7, or D.

e = Cable options 1, 2, 3, 4, 5, 6, 7, 8, 9, A, B, C, D, E, F, G, H, J, K, L, M, N, P, R, S, Z.

f = Sensing element 101, 102, 103, 104, 105, 106, 107, 108, 109, 110, 111, 112, 113, 301, 302, 303, 304, 305, 306, 307, 308, 309, 310, 311, 312, 313, 314, 315, 316, 317, 318, 319, 320, 321, 322, 323, 324, 325, 326, 327, 328, 329, 330, 331, 332, 333, 334, 335, 601, 603, 604, 605, 606, 607, 608, 609, 610, 611, 612, or 613.

g = 24 character numbering system not affecting safety.

Special Conditions of Use:

1. In Zone 0 locations, care must be taken when installing the aluminium enclosure that even in the event of rare incidents, an ignition source due to impact or friction between the enclosure and iron / steel is excluded.

700-a, Sensor.

IS / I, II, III / 1 / ABCDEFG / T2...T5 Ta = 75°C – 420-0004-424-CD; System

I / 1 / AEx ia IIC T2...T5 Ta = 75°C – 420-0004-424-CD; System

a = 1202-014, 1202-001, 1202-018, 1202-041, 0001-022, 0001-024, 0001-026, 0001-034, 0001-044, 0001-054, 0001-0634, 0001-344, 0002-023, 0002-024, 0002-027, 0002-028, 0002-033, 0002-054, 0002-321, 0002-360, 0005-054, 0201-005, 0201-025, 0201-026, 0201-028, 0201-036, 1202-031, 1202-033, 1202-061, 1202-081, 0001-016, 0001-324, 0003-009, 0005-035, 0005-048, 0005-348, 0202-036, 0202-043, 0001-040, 0001-074, 0002-037, 0002-040, 0002-044, 0002-057, 0002-064, 0002-224, 0002-321, 0201-027, 0201-051, 0201-052, 0201-058, 0201-059, 0202-002, 0202-053, 0001-018, 0001-045, 0002-027, 0002-029, 0002-036, 0002-046, 0002-059, 0002-227, 0002-363, 0004-031, 0004-050, 0005-009, 0005-018, 0005-019, 0005-028, 0005-029, 0005-036, 0005-045, 0005-085, 0005-095, 0005-096, 0005-354, 0009-002, 0009-024, 0009-057, 011-001, 011-003, 011-015, 0021-001, 0021-002, 0021-003, 0021-007, 0202-054, 0202-056, 0203-003, 0203-004, 0204-002, 0204-022, 0204-024, 0204-038, 0204-048, 0204-049, 0205-005, 0205-015, 0205-018, 0205-075, 0205-078, 0205-079, 0209-002, 0209-024, 1202-010, 9100-403, 1202-061, 9100-195, 1202-051, or any other 7 digit numeric combination maintaining the limits of 420-0004-412-CD.

Equipment Ratings:

The Universal IV Level Transmitter is rated as Intrinsically Safe for Class I, II and III, Groups A-G and Class I, Zone 0, Group IIC, in accordance with drawing 420-0004-412-12; Nonincendive Class I, Division 2, Groups A-D Hazardous (Classified) Locations.

Furthermore, the Integral version is rated as Explosionproof for Class I, Division 1, Groups C & D; Dust Ignitionproof for Class II & III, Division 1, Groups E-G and Class I, Zone 1, Group IIB Hazardous (Classified) Locations with an integral sensor that is Intrinsically Safe for Class I, II & III, Groups A-G and Class I, Zone 1 Hazardous (Classified) Locations. The Remote version is rated as Explosionproof Class I, Division 1, Groups C & D; Dust-Ignitionproof for Class II & III, Division 1, Groups E-G and Class I, Zone 1, Group IIB Hazardous (Classified) Locations with connections to a 700 Series sensor that is Intrinsically Safe for Class I, II & III, Groups A-G and Class I, Zone 1 Hazardous (Classified) Locations.

FM Approved for:

AMETEK Drexelbrook
Horsham, PA

8.1 FM US Approval Certificate (Continued)

420-0004-429	ShL of	5 5	ISSUE 2
--------------	-----------	--------	------------



Member of the FM Global Group

This certifies that the equipment described has been found to comply with the following Approval Standards and other documents:

FM Class 3600	2011
FM Class 3610	2010
FM Class 3611	2004
FM Class 3615	2006
ANSI / ISA 60079-0	2009
ANSI / ISA 60079-1	2009
ANSI / ISA 60079-11	2011
ANSI / ISA 60079-31	2009
ANSI / IEC 60529	2004

Original Project ID: 3043661

Approval Granted: 11 May 2012

Subsequent Revision Reports / Date Approval Amended

Report Number	Date	Report Number	Date
---------------	------	---------------	------

FM Approvals LLC



J.E. Marquedant
Group Manager, Electrical

11 May 2012

Date

8.1 FM US Approval Certificate (Continued)

420-0004-429	Sh. of	5 5	ISSUE	2
--------------	--------	--------	-------	---



This certifies that the equipment described has been found to comply with the following Approval Standards and other documents:

FM Class 3600	2011
FM Class 3610	2010
FM Class 3611	2004
FM Class 3615	2006
ANSI / ISA 60079-0	2009
ANSI / ISA 60079-1	2009
ANSI / ISA 60079-11	2011
ANSI / ISA 60079-31	2009
ANSI / IEC 60529	2004

Original Project ID: 3043661

Approval Granted: 11 May 2012

Subsequent Revision Reports / Date Approval Amended

Report Number	Date	Report Number	Date
---------------	------	---------------	------

FM Approvals LLC



J.E. Marquedant
Group Manager, Electrical

11 May 2012

Date

8.2 FM Canada Approval Certificate

420-0004-430		Shf. 1 of 5	APP'D BY SGA
ISSUE	EDD NO.	APP'D	DATE
1	5-12-106	SGA	5/17/12
2	10-12-106	<i>Sub</i>	<i>12/18/12</i>



FM Approvals
 1151 Boston Providence Turnpike
 P.O. Box 9102 Norwood, MA 02062 USA
 T: 781 762 4300 F: 781-762-9375 www.fmapprovals.com

CERTIFICATE OF COMPLIANCE

HAZARDOUS LOCATION ELECTRICAL EQUIPMENT PER CANADIAN REQUIREMENTS

This certificate is issued for the following equipment:

Uab102cd00-e-f. Universal IV - Integral

XP-IS / I / 1 / CD / T4 Ta = 75 °C – 420-0004-424-CD; System

I / 1 / Ex d ia IIB T4 Ta = 75 °C – 420-0004-424-CD; System

DIP-IS / II, III / 1 / EFG / T4 Ta = 75 °C – 420-0004-424-CD; System

NI / I / 2 / ABCD / T4 Ta = 75 °C

Type 4, 4X; IP66

a = Type P, L, or C.

b = Frequency and Phasing 0, 1, 2, or 3.

c = Entries 0 or 2.

d = Surge/Noise suppression 0 or 1.

e = Sensing element R111, R112, R113, R114, R115, 251, 252, 253, 254, 255, 256, 257, 258, 259, 260, 261, 262, 301, 302, 303, 304, 305, 306, 307, 308, 309, 310, 311, 312, 313, 314, 315, 316, 317, 318, 319, 320, 321, 322, 323, 324, 325, 326, 327, 502, 503, 504, 505, 506, 507, 508, 510, 511, or 512.

f = 24 character numbering system not affecting safety.

Uab102cd01-e-f. Universal IV - Integral with Dual Seal

XP-IS / I / 1 / CD / T4 Ta = 75 °C – 420-0004-424-CD; System

I / 1 / Ex d ia IIB T4 Ta = 75 °C – 420-0004-424-CD; System

DIP-IS / II, III / 1 / EFG / T4 Ta = 75 °C – 420-0004-424-CD; System

NI / I / 2 / ABCD / T4 Ta = 75 °C

Type 4, 4X; IP66

a = Type P, L, or C.

b = Frequency and Phasing 0, 1, 2, or 3.

c = Entries 0 or 2.

d = Surge/Noise suppression 0 or 1.

e = Sensing element 101, 102, 103, 104, 105, 106, 107, 108, 109, 110, 111, 112, 113, 301, 302, 303, 304, 305, 306, 307, 308, 309, 310, 311, 312, 313, 314, 315, 316, 317, 318, 319, 320, 321, 322, 323, 324, 325, 326, 327.

f = 24 character numbering system not affecting safety.

8.2 FM Canada Approval Certificate (Continued)

420-0004-430	Sht. 2	ISSUE 2
	of 5	



Uab101cd00-e-f. Universal IV - Integral

IS / I, II, III / 1 / ABCDEFG / T4 Ta = 75 °C – 420-0004-412-CD; Entity

I / 0 / Ex ia IIC T4 Ta = 75 °C – 420-0004-412-CD; Entity

NI / I / 2 / ABCD / T4 Ta = 75°C;

Type 4, 4X; IP66

Entity Parameters: Ui = 30 V, Ii = 140 mA, Pi = 1 W, Ci = 0, Li = 0

a = Type P, L, or C.

b = Frequency and Phasing 0, 1, 2, or 3.

c = Entries 0 or 2.

d = Surge/noise suppression 0 or 1.

e = Sensing element R00, R01, R02, R03, R04, R05, 251, 252, 253, 254, 255, 256, 257, 258, 259, 260, 261, 262, 301, 302, 303, 304, 305, 306, 307, 308, 309, 310, 311, 312, 313, 314, 315, 316, 317, 318, 319, 320, 321, 322, 323, 324, 325, 326, 327, 328, 329, 330, 331, 332, 333, 334, 335, 501, 502, 503, 504, 505, 506, 507, 508, 509, 510, 511, 512, 513, 601, 603604, 605, 606, 607, 608, 609, 610, 611, 613, 703, 705, 706, 708, 709, 713, 714, 715, 722, or any other 7 digit numeric combination maintaining the limits of 420-0004-412-CD.

f = 24 character numbering system not affecting safety.

Uab101cd01-e-f. Universal IV – Integral with Dual Seal

IS / I, II, III / 1 / ABCDEFG / T4 Ta = 75 °C – 420-0004-412-CD; Entity

I / 0 / Ex ia IIC T4 Ta = 75 °C – 420-0004-412-CD; Entity

NI / I / 2 / ABCD / T4 Ta = 75°C;

Type 4, 4X; IP66

Entity Parameters: Ui = 30 V, Ii = 140 mA, Pi = 1 W, Ci = 0, Li = 0

a = Type P, L, or C.

b = Frequency and Phasing 0, 1, 2, or 3.

c = Entries 0 or 2.

d = Surge/noise suppression 0 or 1.

e = Sensing element 101, 102, 103, 104, 105, 106, 107, 108, 109, 110, 111, 112, 113, 301, 302, 303, 304, 305, 306, 307, 308, 309, 310, 311, 312, 313, 314, 315, 316, 317, 318, 319, 320, 321, 322, 323, 324, 325, 326, 327, 328, 329, 330, 331, 332, 333, 334, 335, 601, 603, 604, 605, 606, 607, 608, 609, 610, 611, 613.

f = 24 character numbering system not affecting safety.

Uab102cde0-f-g. Universal IV - Remote

XP-AIS / I / 1 / CD / T4 Ta = 75 °C – 420-0004-424-CD; System

I / 1 / Ex d [ja] IIB T4 Ta = 75 °C – 420-0004-424-CD; System;

DIP-AIS / II, III / 1 / EFG / T4 Ta = 75 °C;

NI / I / 2 / ABCD / T4 Ta = 75 °C;

Type 4, 4X; IP66

a = Type P, L, or C.

b = Frequency and Phasing 0, 1, 2, or 3.

c = Entries 0 or 2.

d = Surge/Noise suppression 0, 1, 2, 3, 4, 5, 6, 7, or D

e = Cable options 1, 2, 3, 4, 5, 6, 7, 8, 9, A, B, C, D, E, F, G, H, J, K, L, M, N, P, R, S, or Z

f = Sensing element RO9, 000, 101, 102, 103, 104, 105, 106, 107, 108, 109, 110, 111, 112, 113, 301, 302, 303, 304, 305, 306, 307, 308, 309, 310, 311, 312, 313, 314, 315, 316, 317, 318, 319, 320, 321, 322, 323, 324, 325, 326, 327, 328, 329, 330, 331, 332, 333, 334, 335, 501, 502, 503, 504, 505, 506, 507, 508, 509, 510, 513, 601, 603, 604, 605, 606, 607, 608, 609, 607, 608, 609, 610, 611, 612, 613, 701, 702, 703, 704, 705, 706, 707, 708, 709, 710, 711, 712, 713, 714, 715, 716, 717, 718, 719, 720, 721, 722, 723, 724, 725, 726, 727, 728, 729, 730, 731, 732, 735, 736, 737, 738, 739, 740, 741, 742, 743, 744, 745, 746, 747, 748, 749, 750, 751, 752, or any other 7 digit numeric combination maintaining the limits of 420-0004-412-CD.

g = 24 character numbering system not affecting safety.

8.2 FM Canada Approval Certificate (Continued)

420-0004-430	Sht. 3	ISSUE
	of 5	2

**Uab102cde1-f.g. Universal IV – Remote with Dual Seal**

XP-AIS / I / 1 / CD / T4 Ta = 75 °C – 420-0004-424-CD; System
 I / 1 / Ex d [ia] IIB T4 Ta = 75 °C – 420-0004-424-CD; System
 DIP-AIS / II, III / 1 / EFG / T4 Ta = 75 °C – 420-0004-424-CD; System
 NI / I / 2 / ABCD / T4 Ta = 75 °C;

Type 4, 4X; IP66

- a = Type P, L, or C.
- b = Frequency and Phasing 0, 1, 2, or 3.
- c = Entries 0 or 2.
- d = Surge/Noise suppression 0, 1, 2, 3, 4, 5, 6, 7, or D.
- e = Cable options 1, 2, 3, 4, 5, 6, 7, 8, 9, A, B, C, D, E, F, G, H, J, K, L, M, N, P, R, S, or Z
- f = Sensing element 101, 102, 103, 104, 105, 106, 107, 108, 109, 110, 111, 112, 113, 301, 302, 303, 304, 305, 306, 307, 308, 309, 310, 311, 312, 313, 314, 315, 316, 317, 318, 319, 320, 321, 322, 323, 324, 325, 326, 327, 328, 329, 330, 331, 332, 333, 334, 335, 601, 603, 604, 605, 606, 607, 608, 609, 607, 608, 609, 610, 611, 612, or 613.
- g = 24 character numbering system not affecting safety.

Uab101cde0-f.g. Universal IV - Remote

IS / I, II, III / 1 / ABCDEFG / T4 Ta = 75 °C – 420-0004-412-CD; Entity
 I / 0 / Ex ia IIC T4 Ta = 75 °C – 420-0004-412-CD; Entity
 NI / I / 2 / ABCD / T4 Ta = 75 °C;

Type 4, 4X; IP66

Entity Parameters: Ui = 30 V, Ii = 140 mA, Pi = 1 W, Ci = 0, Li = 0

- a = Type P, L, or C.
- b = Frequency and Phasing 0, 1, 2, or 3.
- c = Entries 0 or 2.
- d = Surge/Noise suppression 0, 1, 2, 3, 4, 5, 6, 7, or D.
- e = Cable options 1, 2, 3, 4, 5, 6, 7, 8, 9, A, B, C, D, E, F, G, H, J, K, L, M, N, P, R, S, Z.
- f = Sensing element RO9, 000, 101, 102, 103, 104, 105, 106, 107, 108, 109, 110, 111, 112, 113, 301, 302, 303, 304, 305, 306, 307, 308, 309, 310, 311, 312, 313, 314, 315, 316, 317, 318, 319, 320, 321, 322, 323, 324, 325, 326, 327, 328, 329, 330, 331, 332, 333, 334, 335, 501, 502, 503, 504, 505, 506, 507, 508, 509, 510, 513, 601, 603, 604, 605, 606, 607, 608, 609, 607, 608, 609, 610, 611, 612, 613, 701, 702, 703, 704, 705, 706, 707, 708, 709, 710, 711, 712, 713, 714, 715, 716, 717, 718, 719, 720, 721, 722, 723, 724, 725, 726, 727, 728, 729, 730, 731, 732, 735, 736, 737, 738, 739, 740, 741, 742, 743, 744, 745, 746, 747, 748, 749, 750, 751, 752, or any other 7 digit numeric combination maintaining the limits of 420-0004-412-CD.
- g = 24 character numbering system not affecting safety.

Uab101cde1-f.g. Universal IV – Remote with Dual Seal

IS / I, II, III / 1 / ABCDEFG / T4 Ta = 75 °C – 420-0004-412-CD; Entity
 I / 0 / Ex ia IIC T4 Ta = 75 °C – 420-0004-412-CD; Entity
 NI / I / 2 / ABCD / T4 Ta = 75 °C;

Type 4, 4X; IP66

Entity Parameters: Ui = 30 V, Ii = 140 mA, Pi = 1 W, Ci = 0, Li = 0

- a = Type P, L, or C.
- b = Frequency and Phasing 0, 1, 2, or 3.
- c = Entries 0 or 2.
- d = Surge/noise suppression 0, 1, 2, 3, 4, 5, 6, 7, or D.
- e = Cable options 1, 2, 3, 4, 5, 6, 7, 8, 9, A, B, C, D, E, F, G, H, J, K, L, M, N, P, R, S, Z.
- f = Sensing element 101, 102, 103, 104, 105, 106, 107, 108, 109, 110, 111, 112, 113, 301, 302, 303, 304, 305, 306, 307, 308, 309, 310, 311, 312, 313, 314, 315, 316, 317, 318, 319, 320, 321, 322, 323, 324, 325, 326, 327, 328, 329, 330, 331, 332, 333, 334, 335, 601, 603, 604, 605, 606, 607, 608, 609, 610, 611, 612, or 613.
- g = 24 character numbering system not affecting safety.

8.2 FM Canada Approval Certificate (Continued)

420-0004-430	Sht. 4	ISSUE
	of 5	2



Member of the FM Global Group

700-a, Sensor.

IS / I, II, III / 1 / ABCDEFG / T2... T5 Ta = 75 °C – 420-0004-424-CD; System;
 I / 1 / Ex ia IIC T2... T5 Ta = 75 °C – 420-0004-424-CD; System;

a = 1202-014, 1202-001, 1202-018, 1202-041, 0001-022, 0001-024, 0001-026, 0001-034, 0001-044, 0001-054, 0001-0634, 0001-344, 0002-023, 0002-024, 0002-027, 0002-028, 0002-033, 0002-054, 0002-321, 0002-360, 0005-054, 0201-005, 0201-025, 0201-026, 0201-028, 0201-036, 1202-031, 1202-033, 1202-061, 1202-081, 0001-016, 0001-324, 0003-009, 0005-035, 0005-048, 0005-348, 0202-036, 0202-043, 0001-040, 0001-074, 0002-037, 0002-040, 0002-044, 0002-057, 0002-064, 0002-224, 0002-321, 0201-027, 0201-051, 0201-052, 0201-058, 0201-059, 0202-002, 0202-053, 0001-018, 0001-045, 0002-027, 0002-029, 0002-036, 0002-046, 0002-059, 0002-227, 0002-363, 0004-031, 0004-050, 0005-009, 0005-018, 0005-019, 0005-028, 0005-029, 0005-036, 0005-045, 0005-085, 0005-095, 0005-096, 0005-354, 0009-002, 0009-024, 0009-057, 011-001, 011-003, 011-015, 0021-001, 0021-002, 0021-003, 0021-007, 0202-054, 0202-056, 0203-003, 0203-004, 0204-002, 0204-022, 0204-024, 0204-038, 0204-048, 0204-049, 0205-005, 0205-015, 0205-018, 0205-075, 0205-078, 0205-079, 0209-002, 0209-024, 1202-010, 9100-403, 1202-061, 9100-195, 1202-051, or any other 7 digit numeric combination maintaining the limits of 420-0004-412-CD.

Equipment Ratings:

The Universal IV Level Transmitter is rated as Intrinsically Safe for Class I, II and III, Groups A-G and Class I, Zone 0, Group IIC, in accordance with drawing 420-0004-412-12; Nonincendive Class I, Division 2, Groups A-D Hazardous Locations.

Furthermore, the Integral version is rated as Explosionproof for Class I, Division 1, Groups C & D; Dust Ignitionproof for Class II & III, Division 1, Groups E-G and Class I, Zone 1, Group IIB Hazardous Locations with an integral sensor that is Intrinsically Safe for Class I, II & III, Groups A-G and Class I, Zone 1 Hazardous Locations. The Remote version is rated as Explosionproof Class I, Division 1, Groups C & D; Dust-Ignitionproof for Class II & III, Division 1, Groups E-G and Class I, Zone 1, Group IIB Hazardous Locations with connections to a 700 Series sensor that is Intrinsically Safe for Class I, II & III, Groups A-G and Class I, Zone 1 Hazardous Locations.

FM Approved for:

AMETEK Drexelbrook
 Horsham, PA

8.2 FM Canada Approval Certificate (Continued)

420-0004-430	Sht. 5 of 5	ISSUE 2
--------------	----------------	------------



This certifies that the equipment described has been found to comply with the following Approval Standards and other documents:

CSA C22.2 No. 0.4 - 1982	Reaffirmed 2009
CSA C22.2 No. 0.5-1982	Reaffirmed 2008
CSA-C22.2 No. 25-1966	Reaffirmed 2009
CSA-C22.2 No. 30-1988	Reaffirmed 2007
CSA-C22.2 No. 94-M91	Reaffirmed 2011
CSA C22.2 No. 142-M1987	Reaffirmed 2009
CSA C22.2 No. 213	Reaffirmed 2008
CSA C22.2 No. 60529	2010
CAN / CSA E60079-0	2007
CAN / CSA E60079-1	2007
CAN / CSA E60079-11:2001-02	2011

Original Project ID: 3043661C

Approval Granted: May 11, 2012

Subsequent Revision Reports / Date Approval Amended

Report Number	Date	Report Number	Date
---------------	------	---------------	------



FM Approvals LLC

 J.E. Marquedant
 Group Manager, Electrical

11 May 2012

Date

8.3 IECEx Approval Certificate

		<h2 style="text-align: center;">IECEx Certificate of Conformity</h2>	
INTERNATIONAL ELECTROTECHNICAL COMMISSION IEC Certification Scheme for Explosive Atmospheres <small>for rules and details of the IECEx Scheme visit www.iecex.com</small>			
Certificate No.:	IECEx FMG 11.0024X	Issue No.:	1
Status:	Current	Certificate history: Issue No. 1 (2012-8-24) Issue No. 0 (2012-5-11)	
Date of Issue:	2012-08-24	Page 1 of 4	
Applicant:	AMETEK Drexelbrook 205 Keith Velez Road Horsham, PA 19044 United States of America		
Electrical Apparatus:	Universal IV Level Transmitter		
Optional accessory:			
Type of Protection:	Intrinsic Safety "I"; Flameproof "d"		
Marking:	Integral: Ex ia IIC T4 Ga; Ex d Ia IIB T4 Gb; Ex tb ia IIIC T90°C Db; -40°C ≤ Ta ≤ +75°C; IP66 Input Voltage: 13-30Vdc; 1W Remote: Ex ia IIC T4 Ga; Ex tb [ia] IIIC T90°C Db; Ex d [ia] IIB T4 Gb; Ex tb [ia] IIIC T90°C Db; -40°C ≤ Ta ≤ +75°C; IP66 Input Voltage: 13-30Vdc; 1W Remote Sensor: Ex ia IIC T5...T2 Ga; Ex ia IIIC T90°C...T300°C Da; -40°C ≤ Ta ≤ +75°C; IP66		
Approved for issue on behalf of the IECEx Certification Body:	J. E. Marquedant		
Position:	Group Manager - Electrical		
Signature: (for printed version)	_____		
Date:	_____		
1. This certificate and schedule may only be reproduced in full. 2. This certificate is not transferable and remains the property of the Issuing body. 3. The Status and authenticity of this certificate may be verified by visiting the Official IECEx Website.			
Certificate issued by:	FM Approvals LLC 1151 Boston-Providence Turnpike Norwood, MA 02062 United States of America		
			

8.3 IECEx Approval Certificate (Continued)

		<h2 style="margin: 0;">IECEx Certificate of Conformity</h2>	
Certificate No.:	IECEx FMG 11.0024X	Issue No.:	1
Date of Issue:	2012-08-24	Page 2 of 4	
Manufacturer:	AMETEK Drexelbrook 205 Keith Valley Road Horsham, PA 19044 United States of America		
Manufacturing location(s):			
<p>This certificate is issued as verification that a sample(s), representative of production, was assessed and tested and found to comply with the IEC Standard list below and that the manufacturer's quality system, relating to the Ex products covered by this certificate, was assessed and found to comply with the IECEx Quality system requirements. This certificate is granted subject to the conditions as set out in IECEx Scheme Rules, IECEx 02 and Operational Documents as amended.</p>			
<p>STANDARDS: The electrical apparatus and any acceptable variations to it specified in the schedule of this certificate and the identified documents, was found to comply with the following standards:</p>			
IEC 60079-0 : 2007-10	Explosive atmospheres - Part 0: Equipment - General requirements		
Edition: 5			
IEC 60079-1 : 2007-04	Explosive atmospheres - Part 1: Equipment protection by flameproof enclosures "d"		
Edition: 6			
IEC 60079-11 : 2011-06	Explosive atmospheres - Part 11: Equipment protection by intrinsic safety "i"		
Edition: 6.0			
IEC 60079-31 : 2008	Explosive atmospheres - Part 31: Equipment dust ignition protection by enclosure "Y"		
Edition: 1			
<p><i>This Certificate does not indicate compliance with electrical safety and performance requirements other than those expressly included in the Standards listed above.</i></p>			
<p>TEST & ASSESSMENT REPORTS: A sample(s) of the equipment listed has successfully met the examination and test requirements as recorded in</p>			
<p><u>Test Report:</u> US/FMG/EXTR11.0027/00</p>		<p>US/FMG/EXTR11.0027/01</p>	
<p><u>Quality Assessment Report:</u> CACSA/QAR06.0008/03</p>			

8.3 IECEx Approval Certificate (Continued)

		IECEx Certificate of Conformity	
Certificate No.:	IECEx FMG 11.0024X	Issue No.:	1
Date of Issue:	2012-08-24	Page	3 of 4
Schedule			
EQUIPMENT: <i>Equipment and systems covered by this certificate are as follows:</i> See attachment for List of Equipment covered by this certificate			
CONDITIONS OF CERTIFICATION: YES as shown below:			
Specific Conditions of Use: Consult the manufacturer if dimensional information on the flameproof joints is necessary. In locations requiring EPL Ga equipment, care must be taken when installing the aluminium enclosure that even in the event of rare incidents, an ignition source due to impact or friction between the enclosure and iron / steel is excluded.			

8.3 IECEx Approval Certificate (Continued)

		IECEx Certificate of Conformity	
Certificate No.:	IECEx FMG 11.0024X	Issue No.:	1
Date of Issue:	2012-08-24	Page	4 of 4
DETAILS OF CERTIFICATE CHANGES (for Issues 1 and above):			
<p>The certificate was updated to match the change to the newer revision of the ExTR. The certificate now refers to ExTr US/FMG/ExTR11.0027/01.</p>			

Annexe: IECEx FMG 11.0024X_Attachment.docx

8.4 ATEX Approval Certificate

1 EC-TYPE EXAMINATION CERTIFICATE 

2 Equipment or Protective systems intended for use in Potentially Explosive Atmospheres - Directive 94/9/EC

3 EC-Type Examination Certificate No: FM12ATEX0018X

4 Equipment or protective system: *U**103**0-*.*, U**104**0-*.*, and 700-** Universal IV Level Transmitter with Integral and Remote Sensor
(Type Reference and Name)

5 Name of Applicant: AMETEK Drexelbrook

6 Address of Applicant: 205 Keith Valley Road, Horsham, PA 19044 USA

7 This equipment or protective system and any acceptable variation thereto is specified in the schedule to this certificate and documents therein referred to.

8 FM Approvals Ltd, notified body number 1725 in accordance with Article 9 of Directive 94/9/EC of 23 March 1994, certifies that this equipment has been found to comply with the Essential Health and Safety Requirements relating to the design and construction of equipment intended for use in potentially explosive atmospheres given in Annex II to the Directive.

The examination and test results are recorded in confidential report number:
3043661EC dated 11 May, 2012

9 Compliance with the Essential Health and Safety Requirements, with the exception of those identified in item 15 of the schedule to this certificate, has been assessed by compliance with the following documents:
EN60079-0:2009, EN60079-1:2007, EN60079-11:2011, EN60079-31:2009, EN60529:1991 + A1:2000

10 If the sign 'X' is placed after the certificate number, it indicates that the equipment is subject to special conditions for safe use specified in the schedule to this certificate.

11 This EC-Type Examination certificate relates only to the design, examination and tests of the specified equipment or protective system in accordance to the directive 94/9/EC. Further requirements of the Directive apply to the manufacturing process and supply of this equipment or protective system. These are not covered by this certificate.

12 The marking of the equipment or protective system shall include:

Universal IV Level Transmitter – Integral
 II 1 G Ex ia IIC T4 Ga -40°C ≤ Tamb ≤ +75°C; IP66 (For models U**103**00-*.*)
 II 2 G Ex d ia IIB T4 Gb -40°C ≤ Tamb ≤ +75°C; IP66 (For models U**104**00-*.*)
 II 2 D Ex tb ia IIIC Db T90°C -40°C ≤ Tamb ≤ +75°C; IP66 (For models U**104**00-*.*)

Universal IV Level Transmitter – Remote (excluding models U10**00-*.*)**
 II 1 G Ex ia IIC T4 -40°C ≤ Tamb ≤ +75°C; IP66 (For models U**103**0-*.*)
 II 2 (1) G Ex d [ia] IIB T4 -40°C ≤ Tamb ≤ +75°C; IP66 (For models U**104**0-*.*)
 II 2 (1) D Ex tb [ia] IIIC T90°C -40°C ≤ Tamb ≤ +75°C; IP66 (For models U**10**0-*.*)

700-*, Universal IV Sensors
 II 1 G Ex ia IIC T2...T5 Ga -40°C ≤ Tamb ≤ +75°C
 II 1 D Ex ia IIIC T300°C...T90°C Da -40°C ≤ Tamb ≤ +75°C

420-0004-432	ISSUE	2	SGA	9/25/11
	EDO NO.	9-12-103	SGA	1/26/12
	APPD	11-12-106		
Sh. of	1	5	APPD BY	
			SGA	
			DATE	

 Digitally signed by Mick Gower, DN: cn=Mick Gower, o=FM Approvals, email=mick.gower@fmapprovals.com, c=GB, Date: 2012.10.16 15:50:23 +0100

Mick Gower
Certification Manager, FM Approvals Ltd.
 Issue date: 16th October 2012

THIS CERTIFICATE MAY ONLY BE REPRODUCED IN ITS ENTIRETY AND WITHOUT CHANGE

FM Approvals Ltd. 1 Windsor Dials, Windsor, Berkshire, UK. SL4 1RS
 T: +44 (0) 1753 750 000 F: +44 (0) 1753 868 700 E-mail: atex@fmapprovals.com www.fmapprovals.com

8.4 ATEX Approval Certificate (Continued)

420-0004-432

Sht. 2
of 5ISSUE
3**SCHEDULE**

FM Approvals

to EC-Type Examination Certificate No. FM12ATEX0018X

13 Description of Equipment or Protective System:

The model series Universal IV Level Transmitter is a two-wire capacitance to current transmitter which provides a 4-20 mA current output signal proportional to a change in capacitance at the probe terminals. It is designed to be used in conjunction with the AMETEK-Drexelbrook Series 700 Capacitance Probes.

The transmitter circuitry is contained on five printed circuit boards and housed in an aluminium housing. Terminals are supplied, and appropriately marked, for power connections and also connection to the sensing probes. A majority of the board set is encapsulated in potting material.

The transmitter electronics operate on a supply of 13 to 30 Vdc with an output range of 4-20 mA. The ambient operating temperature range of the transmitter is -40°F to +167°F (-40°C to 75°C). The Energy Limitation Parameters for the intrinsically safe versions are as follows: $U_i = 30$ V, $I_i = 140$ mA, $P_i = 1$ W, $C_i = 0$, $L_i = 0$

The electronic circuitry is contained in a combination of 5 circuit boards. One of these boards, the Probe Board, is mounted in the main housing and serves as the interface for the probe to the potted electronic module. The remaining 4 circuit boards are assembled in a plastic housing which is potted. The potted assembly contains a Terminal, Display, Power, and Bridge board. There are 3 variations of this potted assembly to service 3 different applications. For these three assemblies, the only differences are different component inclusion/exclusions on the Bridge board.

Model Options:***Uab103de00-f-g. Universal IV – Integral***

a = Type P, L, or C.

b = Frequency and Phasing 0, 1, 2, or 3.

d = Entries 1 or 2

e = Surge/Noise suppression 0 or 1

f = Sensing element R00, R01, R02, R02, R03, R04, R05, 251, 252, 253, 254, 255, 256, 257, 258, 259, 260, 261, 262, 301, 302, 303, 304, 305, 306, 307, 308, 309, 310, 311, 312, 313, 314, 315, 316, 317, 318, 319, 320, 321, 322, 323, 324, 325, 326, 327, 328, 329, 330, 331, 332, 333, 334, 335, 501, 502, 503, 504, 505, 506, 507, 508, 509, 510, 511, 512, 513, 601, 603, 604, 605, 606, 607, 608, 609, 610, 611, 613, 703, 705, 706, 708, 709, 713, 714, 715, 722, or any other 7 digit numeric combination maintaining the limits of 420-0004-424-CD.

g = 24 character numbering system not affecting safety.

Uab104d00-e-f. Universal IV – Integral

a = Type P, L, or C.

b = Frequency and Phasing 0, 1, 2, or 3.

d = Entries 1 or 2

e = Sensing element 251, 252, 253, 254, 255, 256, 257, 258, 259, 260, 261, or 262.

f = 24 character numbering system not affecting safety.

Uab103cde0-f-h. Universal IV – Remote

a = Type P, L, or C.

b = Frequency and Phasing 0, 1, 2, or 3.

c = Entries 1 or 2

d = Surge/Noise suppression 0 or 1

e = Remote Configuration 1, 2, 3, 4, 5, 6, 7, 8, 9, A, B, C, D, E, F, G, H, J, K, L, M, N, O, P, Q, or Z.

f = Sensing element R09, 000, 101, 102, 103, 104, 105, 106, 107, 108, 109, 110, 111, 112, 113, 301, 302, 303, 304, 305, 306, 307, 308, 309, 310, 311, 312, 313, 314, 315, 316, 317, 318, 319, 320, 321, 322, 323, 324, 325, 326, 327, 328, 329, 330, 331, 332, 333, 334, 335, 501, 502, 503, 504, 505, 506, 507, 508, 509, 510, 513, 601, 603, 604, 605, 606, 607, 608, 609, 610, 611, 612, 613, 701, 702, 703, 704, 705, 706, 708, 709, 710, 711, 712, 713, 714, 715, 716, 717, 718, 719, 720, 721, 722, 723, 724, 725, 726, 727, 728, 729, 730, 731, 732, 735, 736, 737, 738, 739, 740, 741, 742, 743, 744, 745, 746, 747, 748, 749, 750, 751, 752, or any other 7 digit numeric combination maintaining the limits of 420-0004-424-CD.

h = 24 character numbering system not affecting safety.

THIS CERTIFICATE MAY ONLY BE REPRODUCED IN ITS ENTIRETY AND WITHOUT CHANGE

FM Approvals Ltd. 1 Windsor Dials, Windsor, Berkshire, UK. SL4 1RS

T: +44 (0) 1753 750 000 F: +44 (0) 1753 868 700 E-mail: atex@fmapprovals.com www.fmapprovals.com

F ATEX 020 (May/12)

Page 2 of 4

8.4 ATEX Approval Certificate (Continued)

420-0004-432	Sht. 3 of 5	ISSUE 3
--------------	----------------	------------



SCHEDULE

to EC-Type Examination Certificate No. FM12ATEX0018X

Uab104de0-f-h. Universal IV – Remote

- a = Type P, L, or C.
- b = Frequency and Phasing 0, 1, 2, or 3.
- d = Entries 1 or 2
- e = Surge/Noise suppression 0, 4 or D.
- f = Remote Configuration 1, 2, 3, 4, 5, 6, 7, 8, 9, A, B, C, D, E, F, G, H, J, K, L, M, N, O, P, Q, or Z.
- g = Sensing element R09, 000, 101, 102, 103, 104, 105, 106, 107, 108, 109, 110, 111, 112, 113, 301, 302, 303, 304, 305, 306, 307, 308, 309, 310, 311, 312, 313, 314, 315, 316, 317, 318, 319, 320, 321, 322, 323, 324, 325, 326, 327, 328, 329, 330, 331, 332, 333, 334, 335, 501, 502, 503, 504, 505, 506, 507, 508, 509, 510, 513, 601, 603, 604, 605, 606, 607, 608, 609, 610, 611, 612, 613, 701, 702, 703, 704, 705, 706, 708, 709, 710, 711, 712, 713, 714, 715, 716, 717, 718, 719, 720, 721, 722, 723, 724, 725, 726, 727, 728, 729, 730, 731, 732, 735, 736, 737, 738, 739, 740, 741, 742, 743, 744, 745, 746, 747, 748, 749, 750, 751, 752, or any other 7 digit numeric combination maintaining the limits of 420-0004-424-CD.
- h = 24 character numbering system not affecting safety.

700-a. Sensor.

- a = 1202-014, 1202-001, 1202-018, 1202-041, 0001-022, 0001-024, 0001-026, 0001-034, 0001-044, 0001-054, 0001-0634, 0001-344, 0002-023, 0002-024, 0002-027, 0002-028, 0002-033, 0002-054, 0002-321, 0002-360, 0005-054, 0201-005, 0201-025, 0201-026, 0201-028, 0201-036, 1202-031, 1202-033, 1202-061, 1202-081, 0001-016, 0001-324, 0003-009, 0005-035, 0005-048, 0005-348, 0202-036, 0202-043, 0001-040, 0001-074, 0002-037, 0002-040, 0002-044, 0002-057, 0002-064, 0002-224, 0002-321, 0201-027, 0201-051, 0201-052, 0201-058, 0201-059, 0202-002, 0202-053, 0001-018, 0001-045, 0002-027, 0002-029, 0002-036, 0002-046, 0002-059, 0002-227, 0002-363, 0004-031, 0004-050, 0005-009, 0005-018, 0005-019, 0005-028, 0005-029, 0005-036, 0005-045, 0005-085, 0005-095, 0005-096, 0005-354, 0009-002, 0009-024, 0009-057, 011-001, 011-003, 011-015, 0021-001, 0021-002, 0021-003, 0021-007, 0202-054, 0202-056, 0203-003, 0203-004, 0204-002, 0204-022, 0204-024, 0204-038, 0204-048, 0204-049, 0205-005, 0205-015, 0205-018, 0205-075, 0205-078, 0205-079, 0209-002, 0209-024, 1202-010, 9100-403, 1202-061, 9100-195, 1202-051, or any other 7 digit numeric combination maintaining the limits of 420-0004-424-CD.

14 Special Conditions for Safe Use:

1. Consult the manufacturer if dimensional information on the flameproof joints is necessary.
2. In locations requiring EPL Ga equipment, care must be taken when installing the aluminium enclosure that even in the event of rare incidents, an ignition source due to impact or friction between the enclosure and iron / steel is excluded.

15 Essential Health and Safety Requirements:

The relevant EHSRs that have not been addressed by the standards listed in this certificate have been identified and assessed in the confidential report identified in item 8.

16 Test and Assessment Procedure and Conditions:

This EC-Type Examination Certificate is the result of testing of a sample of the product submitted, in accordance with the provisions of the relevant specific standard(s), and assessment of supporting documentation. It does not imply an assessment of the whole production.

Whilst this certificate may be used in support of a manufacturer's claim for CE Marking, FM Approvals Ltd accepts no responsibility for the compliance of the equipment against all applicable Directives in all applications.

This Certificate has been issued in accordance with FM Approvals Ltd's ATEX Certification Scheme.

THIS CERTIFICATE MAY ONLY BE REPRODUCED IN ITS ENTIRETY AND WITHOUT CHANGE

FM Approvals Ltd. 1 Windsor Dials, Windsor, Berkshire, UK. SL4 1RS
 T: +44 (0) 1753 750 000 F: +44 (0) 1753 868 700 E-mail: atex@fmapprovals.com www.fmapprovals.com

8.4 ATEX Approval Certificate (Continued)

420-0004-432

Sht. 4
of 5ISSUE
3**SCHEDULE**

FM Approvals

to EC-Type Examination Certificate No. FM12ATEX0018X

17 Schedule Drawings

A list of the significant parts of the technical documentation is annexed to this certificate and a copy has been kept by the Notified Body.

18 Certificate History

Details of the supplements to this certificate are described below:

Date	Description
29 th May 2012	Original Issue.
6 th September 2012	<u>Supplement 1:</u> Report Reference: – 3043661REV120801 dated 24 th August 2012 Description of the Change: Corrected minor errors in drawings and added notes.
16 th October 2012	<u>Supplement 2:</u> Report Reference: – 3043661REV120829 dated 26 th September 2012 Description of the Change: Replacing a potted capacitor.

THIS CERTIFICATE MAY ONLY BE REPRODUCED IN ITS ENTIRETY AND WITHOUT CHANGE

FM Approvals Ltd. 1 Windsor Dials, Windsor, Berkshire, UK. SL4 1RS
T: +44 (0) 1753 750 000 F: +44 (0) 1753 868 700 E-mail: atex@fmapprovals.com www.fmapprovals.com

F ATEX 020 (May/12)

Page 4 of 4

8.4 ATEX Approval Certificate (Continued)

420-0004-432	Sht. 5 of 5	ISSUE 3
--------------	----------------	------------

Blueprint Report

AMETEK Drexelbrook (1000001466)

Class No 3610

AMETEK Drexelbrook (1000001466)

Class No 3610

Original Project I.D. 3043661

Certificate I.D. FM12ATEX0018X

<u>Drawing No.</u>	<u>Revision Level</u>	<u>Drawing Title</u>	<u>Last Report</u>	<u>Electronic Drawing</u>
220-0002-219	2	Combi Screw	3043661	Yes (pdf)
220-0002-246	3	Combi Screw	3043661	Yes (pdf)
242-0001-099	5	Thread Adapter	3043661	Yes (pdf)
250-0001-081	1	O-ring	3043661	Yes (pdf)
260-0002-558	3	Lid Assembly, M105, Viewport	3043661	Yes (pdf)
260-0002-559	4	Lid with Viewport	3043661	Yes (pdf)
260-0002-563	2	Base, ¼ NPT	8/1/12	Yes (pdf)
260-0002-564	2	Base, M20	8/1/12	Yes (pdf)
268-0002-033	1	Skirted Washer	3043661	Yes (pdf)
270-0002-168	6	Sensor label	8/1/12	Yes (pdf)
270-0101-624	2	Label, ¼ NPT Threads	3043661	Yes (pdf)
270-0102-046	1	Label, ia, Integral ATEX/IECEX	3043661	Yes (pdf)
270-0102-047	2	Label, d, Integral ATEX/IECEX	3043661	Yes (pdf)
270-0102-059	1	Label, ia, Remote ATEX/IECEX	3043661	Yes (pdf)
270-0102-060	2	Label, d, Remote ATEX/IECEX	3043661	Yes (pdf)
270-0102-061	1	Label, Sensor Element Housing	3043661	Yes (pdf)
280-0001-058	1	Grounding Stud	3043661	Yes (pdf)
282-0002-053	1	Flat Washer	3043661	Yes (pdf)
282-0004-029	1	Lock Washer	3043661	Yes (pdf)
285-0001-062	3	Condulet Assy	3043661	Yes (pdf)
285-0001-063	3	Condulet Assy	3043661	Yes (pdf)
285-0001-064	3	Condulet Assy	3043661	Yes (pdf)
370-0005-048	4	Lens	3043661	Yes (pdf)
380-0000-132	1	Cable Assy, Signal Filter	3043661	Yes (pdf)
380-0000-133	1	Cable Assy, Probe Filter	3043661	Yes (pdf)
385-0028-010	2	Assy, BOM & Schematics, Desalter Filter Adapter Board	8/1/12	Yes (pdf)
385-0071-001	6	Assy, BOM & Schematics, Display Board	3043661	Yes (pdf)
385-0071-002	6	Assy, BOM & Schematics, Terminal Board	3043661	Yes (pdf)
385-0071-003	8	Assy, BOM & Schematics, Power Board	3043661	Yes (pdf)
385-0071-006	10	Assy, BOM & Schematics, Bridge Board	8/29/12	Yes (pdf)
385-0071-007	6	Assy, BOM & Schematics, Bridge Board 15kHz	3043661	Yes (pdf)
385-0071-008	6	Assy, BOM & Schematics, Bridge Board Cut monitor	8/29/12	Yes (pdf)
385-0071-010	2	Assy, BOM & Schematics, Probe Board	3043661	Yes (pdf)
385-0071-015	4	Assy, BOM & Schematics, Probe Filter Board	8/1/12	Yes (pdf)
385-0071-016	3	Assy, BOM & Schematics, Signal Loop Filter Board	8/1/12	Yes (pdf)
401-0016-028-CD	1	Signal Filter Assy, Customer Drawing	3043661	Yes (pdf)
401-0016-028	2	Signal Filter Assy	3043661	Yes (pdf)
401-0016-029-CD	1	Probe Filter Assy, Customer Drawing	3043661	Yes (pdf)
401-0016-029	2	Probe Filter Assy	3043661	Yes (pdf)
401-0016-031	1	Electrostatic Filter Assy	3043661	Yes (pdf)
420-0004-424-CD	2	ATEX / IECEx Control Drawing	3043661	Yes (pdf)
440-1602-917	3	Artwork, Display Board	3043661	Yes (pdf)
440-1602-918	3	Artwork, Terminal Board	3043661	Yes (pdf)
440-1602-919	4	Artwork, Power Board	3043661	Yes (pdf)
440-1602-920	5	Artwork, Bridge Board	3043661	Yes (pdf)
G320-0002-206	2	Transformer (100KHz)	8/1/12	Yes (pdf)
UXXXXXXXXXX-XX3		Universal IV Integral System	3043661	Yes (pdf)
UXXXXXXXXXX-XX4		Universal IV Remote System	3043661	Yes (pdf)

8.5 CE Mark Declaration of Conformity

420-0004-433		Sht. of	1	APP'D BY	SGA
ISSUE	EDO NO.	APPD	DATE		
1	6-12-100	SGA	6-5-12		

Declaration of Conformity

AMETEK DREXELBROOK
205 KEITH VALLEY ROAD
HORSHAM, PENNSYLVANIA
USA 19044

We declare under our sole responsibility that the product Universal IV Series Level Measurement Systems to which this declaration relates is in conformity with the following standards and entitled to carry the CE Mark:

Product Type: Measurement, Control Equipment and Laboratory Use
Following the provisions of the EMC Directive 2004/108/EC
Conforms to the requirements of:

Emissions requirements of:

EN 61326-1:2006; Clause 7.2:

CISPR 11 Edition 4:2003 Radiated Emissions, Group 1, Class B

Immunity requirements of EN 61326-1:2006; Table 2:

IEC 61 000-4-2: 2001 Electrostatic Discharge

IEC 61000-4-3: 2002 Radiated Immunity

IEC 61 000-4-4: 2004 EFT/Burst. 1/0 leads

IEC 6100Q-4-5: 2001 Surge Immunity, I/O leads

IEC 61 000-4-6: 2003 Conducted Immunity, 1/0 Leads

IEC 61000-4-8: 1993, A1: 2000 Power Frequency Magnetic Fields

Following the provisions of 94/9/EC ATEX Directive,
Conforms to the requirements of:

EN 60079-0 2009	Electrical apparatus for explosive gas atmospheres- Part 0: General requirements
EN 60079-11 2007	Explosive atmospheres- Part 11: Equipment protection by Intrinsic safety "i"
EN 60079-11 (IEC 60079-11, Ed.6) 201X	Electrical apparatus for explosive gas atmospheres -Part 11: Equipment protection by Intrinsic safety "i"
EN 60079-31 2009	Explosive atmospheres -- Part 31: Equipment dust ignition protection by enclosure "t"
EN60529+ A1 2000	Degrees of protection provided by enclosures (IPcode)
EN 60079-1 2007	Explosive Atmospheres- Part I: Equipment protection by flameproof enclosures "d"

EC-Type Examination Certificate Number FM12ATEX0018X Notified Body number 1725

FM Approvals Ltd. 1 Windsor Dials, Windsor, Berkshire, UK. SL4 1 RS

Steven G. Arnold

Steven G. Arnold

Quality Assurance & Product Safety Manager

Issue Date 6-5-2012

TERMS AND CONDITIONS OF SALE

GENERAL: ALL ORDERS ARE SUBJECT TO THE FOLLOWING TERMS AND CONDITIONS. ANY ACCEPTANCE OF ANY OFFER OF BUYER FOR ANY GOODS OR SERVICES IS CONDITIONED UPON THESE TERMS AND CONDITIONS, AND SELLER OBJECTS TO ANY ADDITIONAL OR DIFFERENT TERMS PROPOSED BY BUYER IN ANY DOCUMENT, WHICH SHALL NOT BE BINDING UPON SELLER. No salesman or other party is authorized to bind the AMETEK DREXELBROOK Division of AMETEK, Inc. (hereinafter "Seller") by any agreement, warranty, statement, promise, or understanding not herein expressed, and no modifications shall be binding on Seller unless the same are in writing and signed by an executive officer of Seller or his or her duly authorized representative. Verbal orders shall not be executed until written notification has been received and acknowledged by Seller.

QUOTATIONS: Written quotations are valid for thirty (30) days unless otherwise stated. Verbal quotations expire the same day they are made.

PRICES: All prices and terms are subject to change without notice. Buyer-requested changes to its order ("Orders"), including those affecting the identity, scope and delivery of the goods or services, must be documented in writing and are subject to Seller's prior approval and adjustments in price, schedule and other affected terms and conditions. Orders requiring certified test data in excess of commercial requirements, are subject to a special charge.

ORDER ACCEPTANCE: All Orders are subject to final approval and acceptance by Seller at its office located at 205 Keith Valley Road, Horsham, Pennsylvania 19044.

TERMS OF PAYMENT: Seller's standard terms of payment for Buyers who qualify for credit are net thirty (30) days from date of invoice. All invoices must be paid in United States dollars.

CREDIT: Seller reserves the right at any time to revoke any credit extended to Buyer or otherwise modify terms of payment if Buyer fails to pay for any shipments when due or if in Seller's opinion there is a material adverse change in Buyer's financial condition. Seller may, at its option, cancel any accepted Order if Buyer fails to pay any invoices when due.

DELIVERY: Shipments are F.O.B place of manufacture ("Shipping Point") and the Buyer shall pay all freight, transportation, shipping, duties, fees, handling, insurance, storage, demurrage, or similar charges from Shipping Point. Delivery of goods to common carrier shall constitute delivery and passing of title to the Buyer, and all risk of loss or damage in transit shall be borne by Buyer. Any claims or losses for damage or destruction after such delivery shall be the responsibility of Buyer.

Seller reserves the right to make delivery in installments which shall be separately invoiced and paid for when due, without regard to subsequent deliveries. Delay in delivery of any installment shall not relieve Buyer of its obligation to accept remaining deliveries.

Acknowledged shipping dates are approximate only and based on prompt receipt of all necessary information from Buyer and Buyer's compliance with terms of payment.

TAXES: All sales, excise and similar taxes which Seller may be required to pay or collect with respect to the goods and/or services covered by any Order, shall be for the account of the Buyer except as otherwise provided by law or unless specifically stated otherwise by Seller in writing.

TERMINATION AND HOLD ORDERS: No Order may be terminated by Buyer except upon written request by Buyer and approval by Seller, and if said request is approved by Seller, under the following conditions: (1) Buyer agrees to accept delivery of all of the units completed by Seller through the workday on which Seller receives the written termination request; (2) Buyer agrees to pay to Seller all direct costs and expenses applicable to the portion of the Order that is incomplete.

WARRANTY:

A. Hardware: Seller warrants its goods against defects in materials and workmanship under normal use and service for one (1) year from the date of invoice.

B. Software and Firmware: Unless otherwise specified, Seller warrants for a period of one (1) year from date of invoice that standard software or firmware, when used with Seller specified hardware, shall perform in accordance with Seller's published specifications. Seller makes no representation or warranty, expressed or implied, that the operation of the software or firmware shall be uninterrupted or error-free, or that functions contained therein shall meet or satisfy the Buyer's intended use or requirements.

C. Services: Seller warrants that services, including engineering and custom application, whether provided on a fixed cost or time and material basis, shall be performed in accordance with generally accepted industry practices.

D. Remedies: Seller's liability under this section is restricted to replacing, repairing, or issuing credit (at Seller's option) for any returned goods and only under the following conditions: (1) Seller must be promptly notified, in writing, as soon as possible after the defects have been noted by the Buyer, but not later than (1) year from date of invoice from Seller; (2) The defective goods are to be returned to the place of manufacture, shipping charges prepaid by the Buyer; (3) Seller's inspection shall disclose to its satisfaction that the goods were defective in materials or workmanship at the time of shipment; (4) Any warranty service (consisting of time, travel and expenses related to such services) performed other than at Seller's factory, shall be at Buyer's expense.

E. Repaired/Reconditioned Goods: As to out-of-warranty goods which Seller has repaired or reconditioned, Seller warrants for a period of sixty (60) days from date of its invoice only new components replaced in the most recent repair/reconditioning.

F. Returns and Adjustments: No goods may be returned unless authorized in advance by Seller and then only upon such conditions to which Seller may agree. Buyer must obtain an RMA (Return Material Authorization) number from Seller prior to any return shipment and such RMA number must appear on the shipping label and packing slip. Buyer shall be responsible for the returned goods until such time as Seller receives the same at its plant and for all charges for packing, inspection, shipping, transportation, or insurance associated with returned goods. In the event that credit for returned goods is granted, it shall be at the lesser of the then current prices or the original purchase price. Claims for shortage or incorrect material must be made within five (5) days after receipt of shipment.

ALL OTHER WARRANTIES, FOR ANY OF SELLER'S GOODS OR SERVICES, WHETHER ORAL, WRITTEN, EXPRESS, IMPLIED, STATUTORY OR OTHERWISE, INCLUDING WITHOUT LIMITATION ANY IMPLIED WARRANTY OF MERCHANTABILITY OR FITNESS FOR PURPOSE ARE EXCLUDED.

INTELLECTUAL PROPERTY: Seller's sale of goods or provision of related documentation or other materials to Buyer shall not transfer any intellectual property rights to Buyer unless Seller specifically agrees to do so in writing. Seller shall retain ownership of all applicable patents, trademarks, copyrights and other intellectual property rights. Buyer shall not use, copy or transfer any such items in violation of Seller's intellectual property rights or applicable law, or for any purposes other than that for which the items were furnished.

Seller shall defend any lawsuit brought against the Buyer based on a claim that the design or construction of the goods sold hereunder by Seller infringe any United States or Canadian Patent, Copyright or Mask Work Registration, provided that Buyer promptly notifies Seller of such claim in writing and further provided that, at Seller's expense, (1) Buyer gives Seller the sole right to defend or control the defense of the suit or proceeding, including settlement, and (2) Buyer provides all necessary information and assistance for that defense. In the event of a charge of infringement, Seller's obligation under the agreement shall be fulfilled if Seller, at its option and expense, either (i) settles such claim; (ii) procures for Buyer the right to continue using such goods; (iii) replaces or modifies goods to avoid infringement; or (iv) accepts the return of any infringing goods and refunds their purchase price; or (v) defends against such claim.

If Buyer furnishes specifications or designs to Seller, the obligations of Seller set forth above shall not apply to goods made by Seller using such specifications or designs, and Buyer shall defend, indemnify and hold Seller harmless against any third party claims for infringement which arise out of Seller's use of specifications or designs furnished by Buyer.

SOFTWARE LICENSE: If goods purchased hereunder include software ("Software"), Buyer may use the Software only as part of the goods. Buyer may not use, copy, or transfer any of the Software except as may be permitted under the applicable License Agreement provided with the goods. Buyer's right to use, copy or transfer the Software shall terminate upon termination of Buyer's right to use the goods.

PACKAGING/WEIGHTS AND DIMENSIONS: Buyer specified packing or marking may be subject to additional charges not otherwise included in the price of the goods. Published weights and dimensions are estimates or approximate only and are not warranted.

FORCE MAJEURE: Seller shall not be responsible for delays in delivery or any failure to deliver due to causes beyond Seller's control, including but not limited to the following items: acts of God, war, terrorism, mobilization, civil commotion, riots, embargoes, domestic or foreign governmental regulations or orders, governmental priorities, port congestion, acts of the Buyer, its agents or employees, fires, floods, strikes, lockouts and other labor difficulties, shortages or inability to obtain shipping space or transportation, inability to secure fuel, supplies or power at current prices or on account of shortages thereof, or due to limitations imposed by the extent of availability of Seller's normal manufacturing facilities.

If a delay excused per the above extends for more than ninety (90) days and the parties have not agreed upon a revised basis for continuing providing the goods or services at the end of the delay, including adjustment of the price, then Buyer, upon thirty (30) days' prior written notice to Seller may terminate the Order with respect to the unexecuted portion of the goods or services, whereupon Buyer shall promptly pay Seller its reasonable termination charges upon submission of Seller's invoices thereof.

LIMITATION OF LIABILITY: Seller's liability for any claim of any kind, except infringement of intellectual property rights, shall not exceed the purchase price of any goods or services which give rise to the claim. **SELLER SHALL IN NO EVENT BE LIABLE FOR BUYER'S MANUFACTURING COSTS, LOST PROFITS, LOSS OF USE OF THE GOODS OR SERVICES, COST OF CAPITAL, COST OF SUBSTITUTE GOODS, FACILITIES, SERVICES OR REPLACEMENT POWER, DOWNTIME COSTS, CLAIMS OF BUYER'S CUSTOMERS FOR DAMAGES, OR OTHER SPECIAL, PROXIMATE, INCIDENTAL, INDIRECT, EXEMPLARY OR CONSEQUENTIAL DAMAGES.** Any action against Seller must be brought within eighteen (18) months after the cause of action accrues. These disclaimers and limitations of liability shall apply regardless of the form of action, whether in contract, tort or otherwise, and further shall extend to the benefit of Seller's vendors, appointed distributors and other authorized resellers as third-party beneficiaries.

PROHIBITION FOR HAZARDOUS USE: Goods sold hereunder generally are not intended for application in and shall not be used by Buyer in the construction or operation of a nuclear installation or in connection with the use or handling of nuclear material, or for any hazardous activity or critical application, where failure of a single component could cause substantial harm to persons or property, unless the goods have been specifically approved for such a use or application. Seller disclaims all liability for any loss or damage resulting from such unauthorized use and Buyer shall defend, indemnify and hold harmless the Seller against any such liability, whether as a result of breach of contract, warranty, tort (regardless of the degree of fault or negligence), strict liability or otherwise.

EXPORT CONTROL: Buyer shall comply with all export control laws and regulations of the United States, and all sales hereunder are subject to those laws and regulations. Seller shall not be named as shipper or exporter of record for any goods sold hereunder unless specifically agreed to in writing by Seller. At Seller's request, Buyer shall furnish Seller with end-use and end-user information to determine export license applicability. Buyer warrants, in accordance with U.S. Export Law, that goods sold hereunder shall not be destined for facilities or activities involving nuclear, chemical or biological weapons, or related missile delivery systems in named prohibited regions or countries.

GOVERNING LAW: Seller intends to comply with all laws applicable to its performance under any order. All matters relating to interpretation and effect of these terms and any authorized changes, modifications or amendments thereto shall be governed by the laws of the Commonwealth of Pennsylvania. No government contract regulations or clauses shall apply to the goods or services, this agreement, or act to bind Seller unless specifically agreed to by Seller in writing.

NON-WAIVER BY SELLER: Waiver by Seller of a breach of any of these terms and conditions shall not be construed as a waiver of any other breach.

SEVERABILITY AND ENTIRE AGREEMENT: If any provision of these terms and conditions is unenforceable, the remaining terms shall nonetheless continue in full force and effect. This writing, together with any other terms and conditions Seller specifically agrees to in writing, constitutes the entire terms and conditions of sale between Buyer and Seller and supercedes any and all prior discussions, and negotiations on its subject matter.

DREXELBROOK
An ISO 9001 Certified Company

205 Keith Valley Road, Horsham, PA 19044
U.S. and Canada: 1-800-553-9092
24-Hour Service: 1-800-527-6297
International: +1 215-674-1234
Fax: +1 215-674-2731
E-mail: drexelbrook.info@ametek.com
Website: www.drexelbrook.com