



Installation & Maintenance Instructions

54 Series Pressure Switches

Types

Enclosed: J54, J54A, H54

Skeleton: J54S, J54AS, H54S



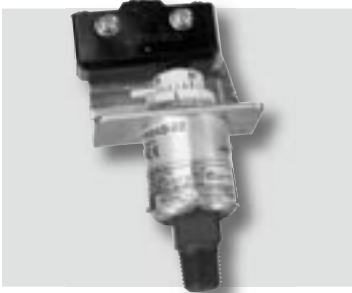

54 Series Pressure Switches

Types

Enclosed: J54, J54A, H54

Skeleton: J54S, J54AS, H54S



UNITED ELECTRIC
CONTROLS

Installation and Maintenance Instructions

Please read all instructional literature carefully and thoroughly before starting. Refer to the final page for the listing of Recommended Practices, Liabilities and Warranties.

GENERAL



BEFORE INSTALLING, CHECK THE SENSOR MODEL SELECTED FOR COMPATIBILITY BETWEEN THE PROCESS MEDIA AND THE SENSOR AND WETTED PARTS.

As the pressure changes, a diaphragm, bellows or piston sensor actuates one or two snap acting switches. The 54 Series offers two types of adjustments: internal hex screw adjustment on "J" types or a reference adjustment dial on "H" types.



PROOF PRESSURE* LIMITS STATED IN THE LITERATURE AND ON NAMEPLATES MUST NEVER BE EXCEEDED, EVEN BY SURGES IN THE SYSTEM. OCCASIONAL OPERATION OF UNIT UP TO PROOF PRESSURE IS ACCEPTABLE (E.G., START-UP, TESTING). CONTINUOUS OPERATION SHOULD NOT EXCEED THE DESIGNATED OVER RANGE PRESSURE.

*PROOF PRESSURE

THE MAXIMUM PRESSURE TO WHICH A PRESSURE SENSOR MAY BE OCCASIONALLY SUBJECTED, WHICH CAUSES NO PERMANENT DAMAGE (E.G., START-UP, TESTING). THE UNIT MAY REQUIRE RE-GAPPING.



THESE PRODUCTS DO NOT HAVE ANY FIELD REPLACEABLE PARTS.

Part I - Installation

Tools Needed

Adjustable Wrench
Screwdriver
Hammer (for alternate wire knockouts)

MOUNTING



LOCATE SWITCH WHERE VIBRATION, SHOCK, AND AMBIENT TEMPERATURE FLUCTUATIONS ARE MINIMAL. TO AVOID DAMAGE TO SWITCH, ALWAYS HOLD THE WRENCH ON THE WRENCH FLATS OR HEX PORTION OF THE PRESSURE CONNECTION WHEN TIGHTENING.

The switch can be mounted in any position.

Enclosed Versions J54, J54A, and H54

Remove cover first by removing the one captive screw located on the front of the cover.

Pipe Mounting

Mount the switch directly to the line via the NPT pressure connection.

Vertical Surface Mount

Two holes for #10 screws are provided in the bracket plate.

Conduit Connection

A 7/8" diameter hole has been provided in the bracket plate for mounting a conduit fitting.

Skeleton Versions J54S, J54AS H54S

Pipe Mounting

Mount the switch directly to the line via the NPT pressure connection.

Vertical Surface Mount

Two openings for #6 screws are provided in the rear of the bracket plate. (See Figure 1).

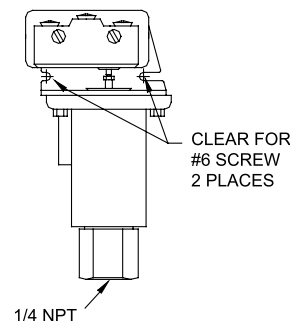

Figure 1

WIRING



DISCONNECT ALL SUPPLY CIRCUITS BEFORE WIRING UNIT. WIRE UNITS ACCORDING TO NATIONAL AND LOCAL ELECTRICAL CODES. MAXIMUM RECOMMENDED WIRE SIZE IS 14 AWG. THE RECOMMENDED TIGHTENING TORQUE FOR FIELD WIRING TERMINALS IS 7 TO 17 IN-LBS.

Bring wires up to the terminals from the rear, so that wires lay along insulator.



ELECTRICAL RATINGS STATED IN LITERATURE AND ON NAMEPLATES MUST NEVER BE EXCEEDED - OVERLOAD ON A SWITCH CAN CAUSE FAILURE ON THE FIRST CYCLE.

Part II - Adjustments

Tools Needed

1/4" open end wrench
Flatblade screwdriver

Uncalibrated Single Switch Versions J54, J54S

Mount switch onto a calibrated pressure source (vacuum source for model 22). Secure fitting to source tight enough to prevent leaks. Use pipe sealant or Teflon® tape to ensure tight seal. Apply tightening torque to the fitting only.



USING THE SENSOR HOUSING OR BRACKET TO TIGHTEN THE FITTING TO THE SOURCE WILL RESULT IN DAMAGE TO THE SWITCH.

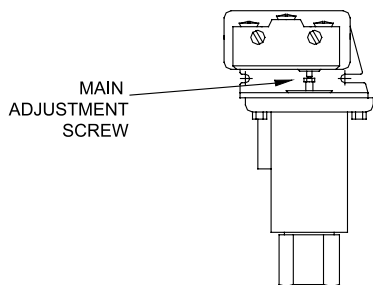

Figure 2

Using a 1/4" open end wrench, turn main adjustment screw counterclockwise (out of sensor plunger) to lower set point or clockwise (into sensor plunger) to raise set point. (See Figure 2).



ALWAYS RECHECK SET POINTS AFTER ANY ADJUSTMENTS ARE MADE.

Calibrating Single Switch Versions H54, H54S

Turn the reference dial to desired set point by aligning setting on dial with dowel pin. (See Figure 3).

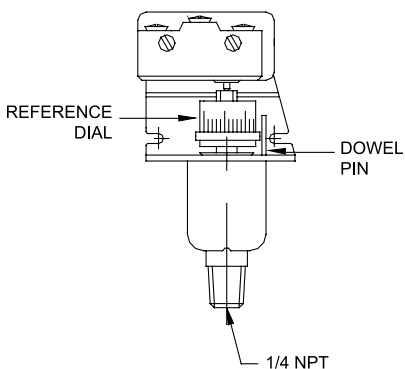

Figure 3

Calibrating All Dual Switch Versions J54A, J54AS

Mount switch via an NPT pressure connection onto a calibrated pressure source (vacuum source for model 22). Secure fitting to source tight enough to prevent leaks. Use pipe sealant or Teflon® tape to ensure tight seal. Apply tightening torque to the fitting only.



USING THE SENSOR HOUSING OR BRACKET TO TIGHTEN THE FITTING TO THE SOURCE WILL RESULT IN DAMAGE TO THE SWITCH.

High Set of Range

Using a 1/4" open end wrench, turn main adjustment screw counterclockwise (out of sensor plunger) to lower set point or clockwise (into sensor plunger) to raise set point. Turning the 1/4" hex screw clockwise until "high set" switch transfers at the target pressure point provides a pressure rise set point. (See Figure 4).

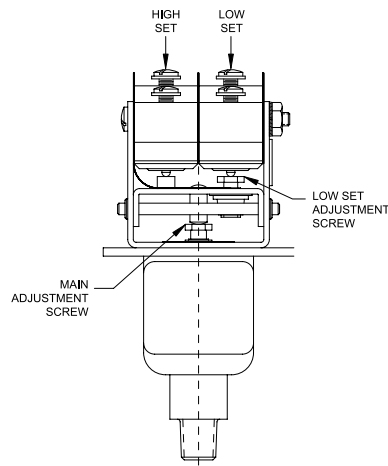

Figure 4

Low Set of Range

Using a 1/4" open end wrench, turn "low set" adjustment screw counterclockwise (out of sensor plunger) to lower set point or clockwise (into sensor plunger) to raise set point. Turn screw until both "high set" and "low set" switches transfer together on or near the target pressure on rise. Turn the "low set" switch adjustment screw clockwise (into sensor plunger) until the "low set" switch transfers at the desired pressure on fall (unless required otherwise). Raise the pressure source to the "high set" pressure value to check the set point pressure. Adjust the 1/4" hex screw accordingly if further fine adjustments are needed. Lower pressure to check the set point of the "low set". Fine adjust if necessary. (See Figure 4).

Manual Reset, Option 1530

A snap-acting switch with this option will remain tripped until pressure changes (falls) and the reset button is manually depressed, which resets the switch.

Dimensions

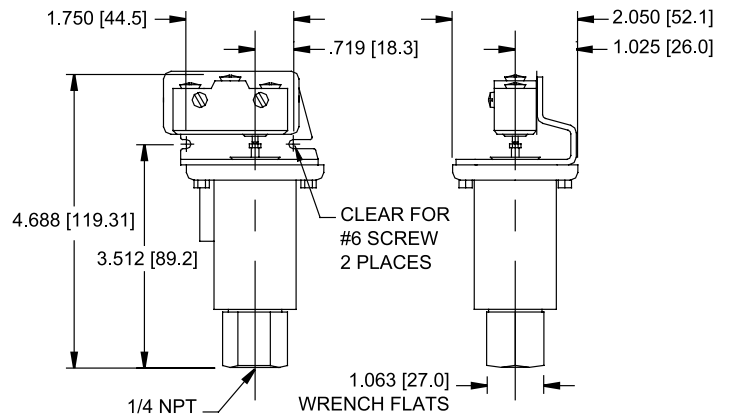
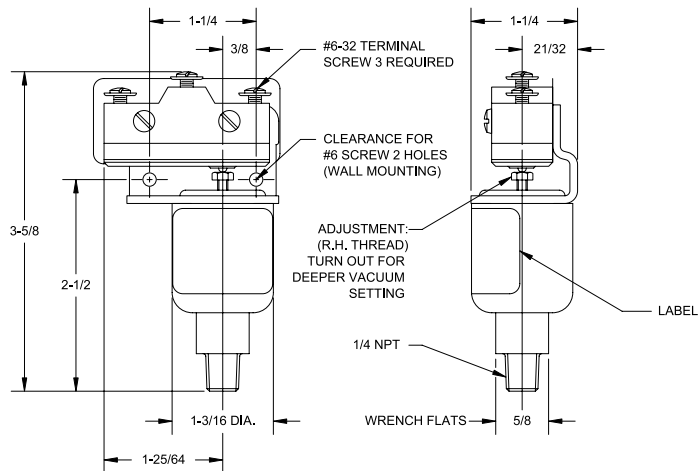

Type J54S models 22-28

Type J54S models 610-614

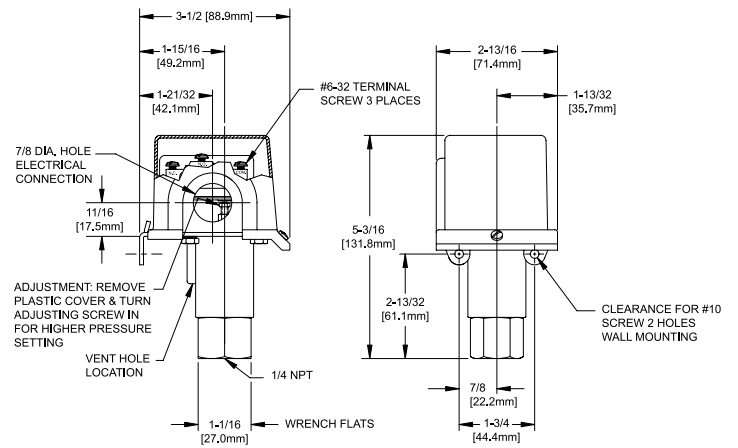
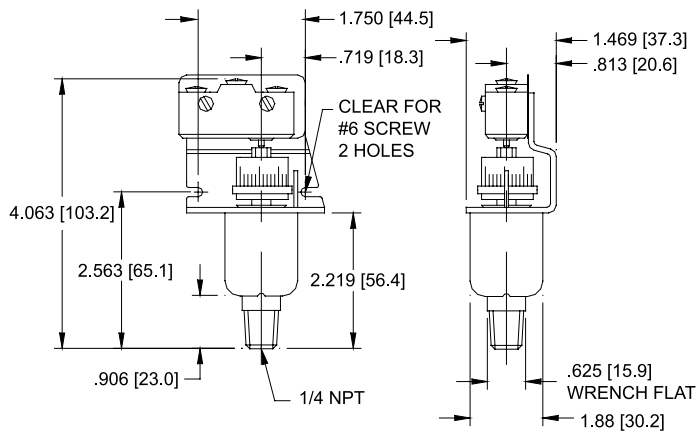

Type H54S models 22-28

Type J54 models 610-614

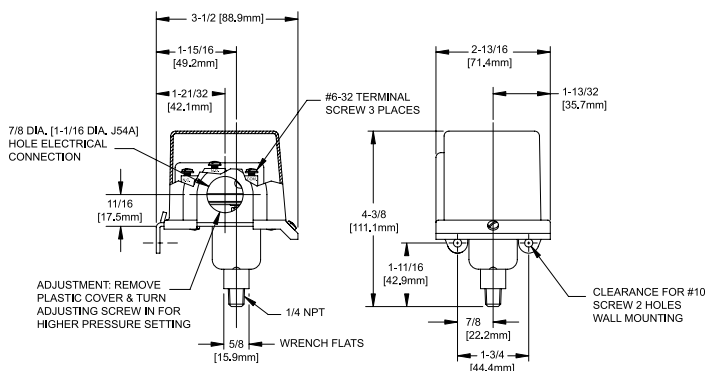

Type H54, J54 & J54A models 22-28

RECOMMENDED PRACTICES AND WARNINGS

United Electric Controls Company recommends careful consideration of the following factors when specifying and installing UE pressure and temperature units. Before installing a unit, the Installation and Maintenance instructions provided with unit must be read and understood.

- To avoid damaging unit, proof pressure and maximum temperature limits stated in literature and on nameplates must never be exceeded, even by surges in the system. Operation of the unit up to maximum pressure or temperature is acceptable on a limited basis (e.g., start-up, testing) but continuous operation must be restricted to the designated adjustable range. Excessive cycling at maximum pressure or temperature limits could reduce sensor life.
- A back-up unit is necessary for applications where damage to a primary unit could endanger life, limb or property. A high or low limit switch is necessary for applications where a dangerous runaway condition could result.
- The adjustable range must be selected so that incorrect, inadvertent or malicious setting at any range point cannot result in an unsafe system condition.
- Install unit where shock, vibration and ambient temperature fluctuations will not damage unit or affect operation. When applicable, orient unit so that moisture does not enter the enclosure via the electrical connection. When appropriate, this entry point should be sealed to prevent moisture entry.
- Unit must not be altered or modified after shipment. Consult UE if modification is necessary.
- Monitor operation to observe warning signs of possible damage to unit, such as drift in set point or faulty display. Check unit immediately.
- Preventative maintenance and periodic testing is necessary for critical applications where damage could endanger property or personnel.
- Electrical ratings stated in literature and on nameplate must not be exceeded. Overload on a switch can cause damage, even on the first cycle. Wire unit according to local and national electrical codes, using wire size recommended in installation sheet.
- Do not mount unit in ambient temp. exceeding published limits.

LIMITED WARRANTY

Seller warrants that the product hereby purchased is, upon delivery, free from defects in material and workmanship and that any such product which is found to be defective in such workmanship or material will be repaired or replaced by Seller (Ex-works, Factory, Watertown, Massachusetts. INCOTERMS); provided, however, that this warranty applies only to equipment found to be so defective within a period of 24 months from the date of manufacture by the Seller. Seller shall not be obligated under this warranty for alleged defects which examination discloses are due to tampering, misuse, neglect, improper storage, and in any case where products are disassembled by anyone other than authorized Seller's representatives. EXCEPT FOR THE LIMITED WARRANTY OF REPAIR AND REPLACEMENT STATED ABOVE, SELLER DISCLAIMS ALL WARRANTIES WHATSOEVER WITH RESPECT TO THE PRODUCT, INCLUDING ALL IMPLIED WARRANTIES OF MERCHANTABILITY OR FITNESS FOR ANY PARTICULAR PURPOSE.

LIMITATION OF SELLER'S LIABILITY

Seller's liability to Buyer for any loss or claim, including liability incurred in connection with (i) breach of any warranty whatsoever, expressed or implied, (ii) a breach of contract, (iii) a negligent act or acts (or negligent failure to act) committed by Seller, or (iv) an act for which strict liability will be inputted to seller, is limited to the "limited warranty" of repair and/or replacement as so stated in our warranty of product. In no event shall the Seller be liable for any special, indirect, consequential or other damages of a like general nature, including, without limitation, loss of profits or production, or loss or expenses of any nature incurred by the buyer or any third party.

UE specifications subject to change without notice.



UNITED ELECTRIC
CONTROLS

180 Dexter Avenue, P.O. Box 9143
Watertown, MA 02471-9143 USA
Telephone: 617 926-1000 Fax: 617 926-2568
<http://www.ueonline.com>