

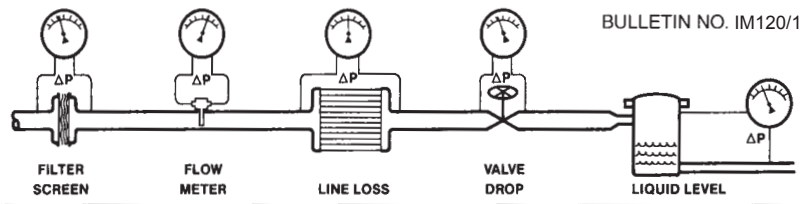

Installation & Maintenance Instructions

# Model 120 "Filter Minder" & Model 120 Electrical

**Mid-West<sup>®</sup> Instrument**



## Model 120 Series "Filter Minder"<sup>®</sup> Installation and Operating Instructions

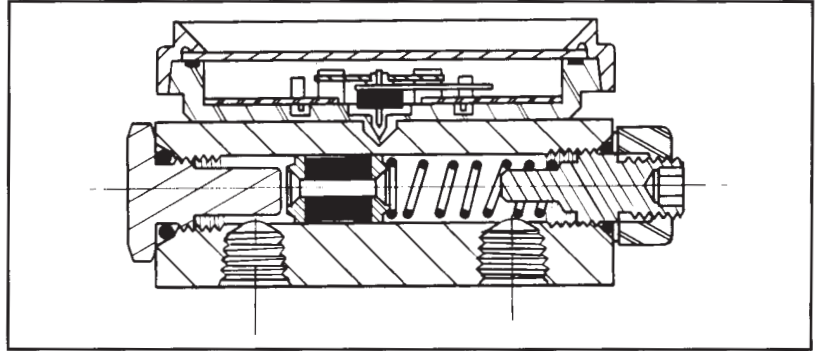
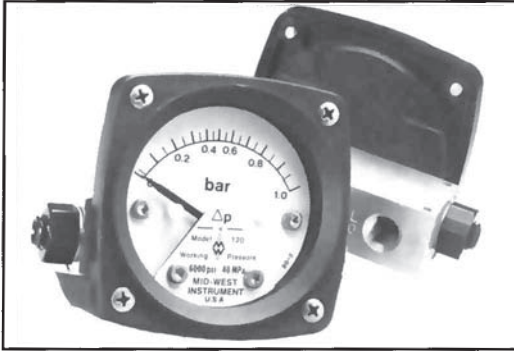

### INSPECTION

Before installation check the nameplate on each instrument against the receiving paperwork and the intended application for correct part number, materials of construction, working pressure, dial range, etc. If equipped with switches, check electrical rating, type of enclosure, etc. Inspect for shipping damage and, if damaged, report it immediately.

**NOTE - Before attempting repairs contact your local Mid-West Representative or our factory. Failure to do so will void any warranty.**

### PRODUCT DESCRIPTION

The Model 120 Series "Filter Minder"<sup>®</sup> is a rugged, medium-range differential pressure instrument available as a switch, a gauge, or both. See "Part Numbering System". (Fig. 4) for available options.

Differential pressure is sensed by the movement of a floating piston magnet against a calibrated spring. The magnetically coupled gauge pointer outside the pressure housing follows the movement of the piston magnet and indicates differential pressure on the dial scale.

When equipped with switches, a contact is made or broken by the magnetic field of the piston magnet. See Bulletin ELECIM120/latest for gauges with switches.

The unit provides full over-range protection to the rated working pressure of the housing in either direction.

The precise piston/bore fit allows minimal leakage from high to low sides. This leakage is only 5 to 15 SCFH air at ambient conditions and a pressure differential of 100 PSID.

### INSTALLATION

Model 120 Series "Filter Minder"<sup>®</sup> is calibrated and tested prior to shipment and is ready for immediate installation. Use of the following installation procedures should eliminate potential damage and provide optimum trouble-free operation.

#### **1. CONNECTIONS**

1/4" FNPT are provided as standard but check paperwork for connections ordered. There are two connections on the housing identified as "hi" and "lo" for high pressure and low pressure (Fig. 2). Be sure these get plumbed to the proper connections on your system. Improper connection will not damage the instrument, but it will not function properly. Flexible tubing is recommended to minimize the effect of any vibration that may exist.

#### **2. INSTRUMENT LOCATION**

On liquid service the instrument should be mounted **below** the process connections to facilitate self-bleeding. On gas service it should be located **above** the process connections to promote self-draining. If the process contains particulates, a "pigtail" loop or drop leg (manometer "U-tube" configuration) in the tubing will minimize the possibility of it migrating into the instrument.

### 3. PANEL MOUNTING

Gauges with 2-1/2" dials can **only** be mounted through the **rear** of the panel. Make the proper panel cutout as indicated in (Fig.1). Remove the (4) bezel screws. Insert the gauge front through the rear of the panel and reinstall the bezel screws through the **front** of the panel and into the gauge bezel. Tighten the screws securely, alternating in a **diagonal** pattern.

Gauges with 3-1/2" dial should be mounted from the front of the panel. Contact factory for mounting information and dimensional data.

Gauges with 4-1/2" dial should be mounted from the **front** of the panel. Make the cutout as indicated in (Fig. 1). Insert the (4) panel mounting studs, finger tight, into the metal inserts located in the rear of the bezel. Insert the gauge through the panel, aligning the panel mounting studs with the holes in the panel. Install the (4) #8-32 nuts onto the studs and tighten securely.

### 4. PIPE MOUNTING

An optional pipe mounting kit is available for mounting the gauge to a 2" vertical or horizontal pipe (Fig. 3).

### TROUBLE SHOOTING

#### 1. Gauge does not indicate differential.

- A. Check for proper hook up, high to "hi" and low to "lo".
- B. Make certain block valves are open and, if using a 3-valve manifold, that the equalizer (balance) valve is closed.
- C. If A & B check out correctly, loosen or disconnect the high pressure line to determine if there is pressure to the instrument.
- D. If there is pressure to the instrument, check to determine that there is differential across the unit being monitored. If so, contact the factory for assistance and/or an "RGA" (return goods authorization) number to return the instrument for repair or replacement.

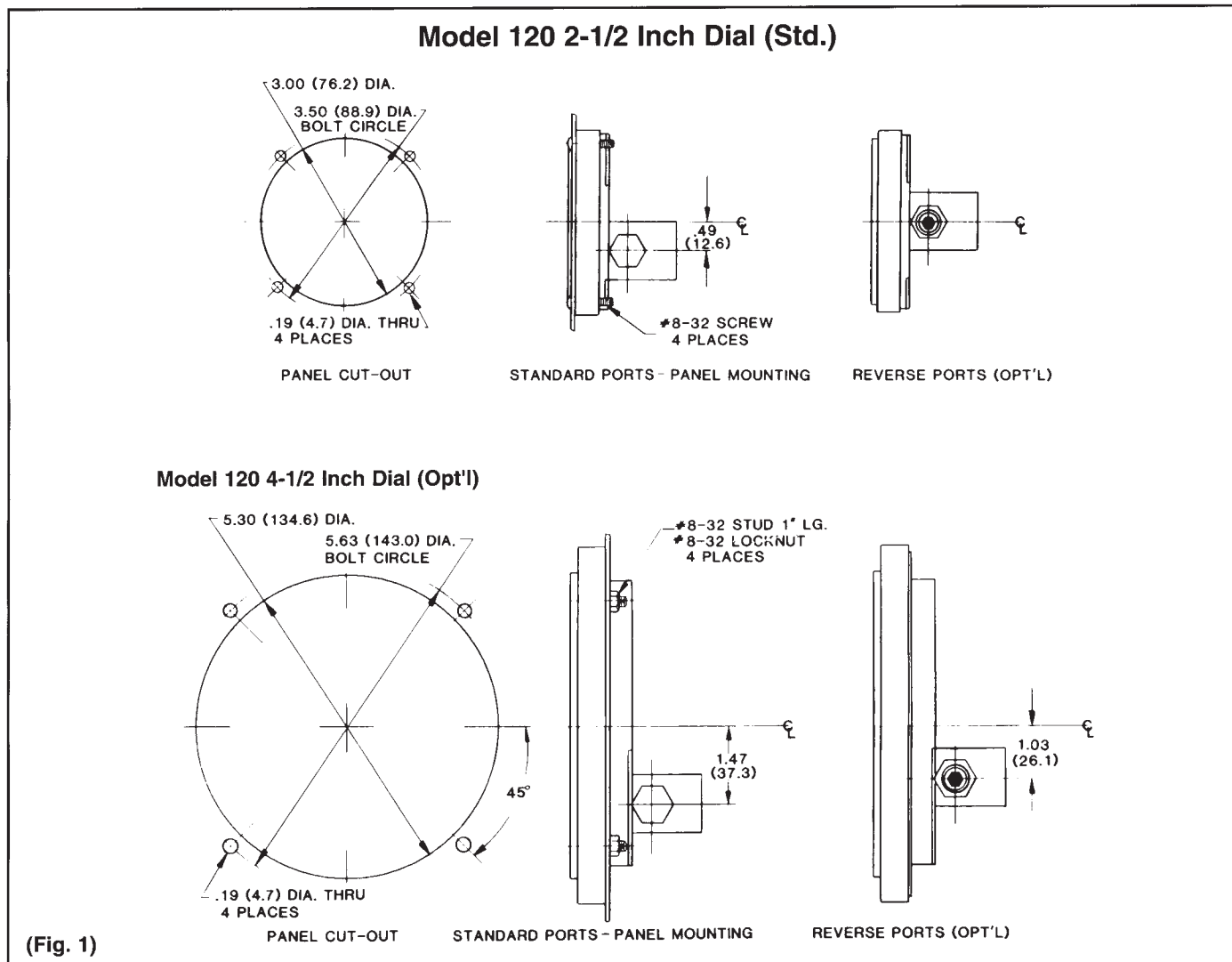

## Supplementary 120 Dimensional/Mounting Data

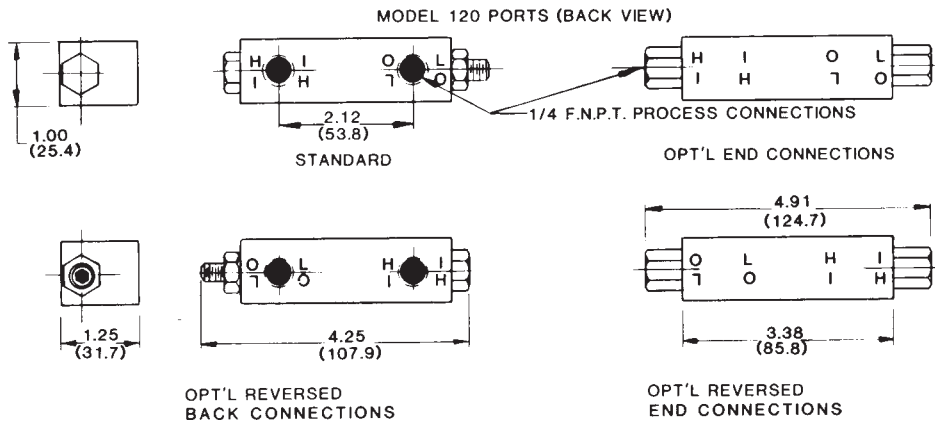

(Fig. 2)

### TYPICAL 2" PIPE MOUNTING (BACK CONNECTIONS ONLY)

3.75 (95) FOR 2-1/2 INCH DIAL  
4.18 (106.1) FOR 4-1/2 INCH DIAL

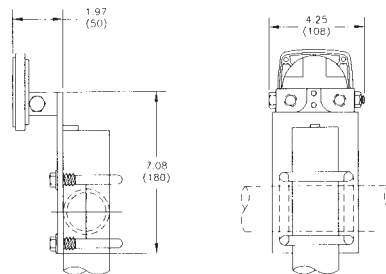

### TYPICAL WALL MOUNTING 4-1/2 INCH DIAL (BACK OR END CONNECTIONS)

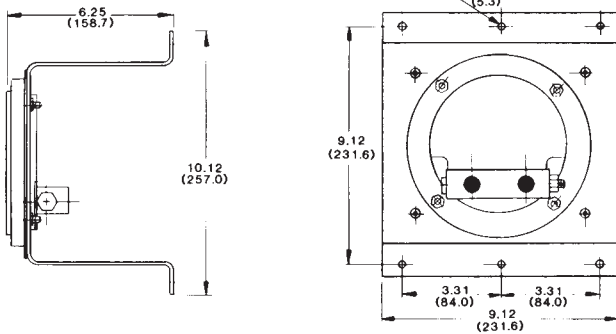

### TYPICAL WALL MOUNTING 2-1/2 INCH DIAL (END CONNECTION OPTION ONLY)

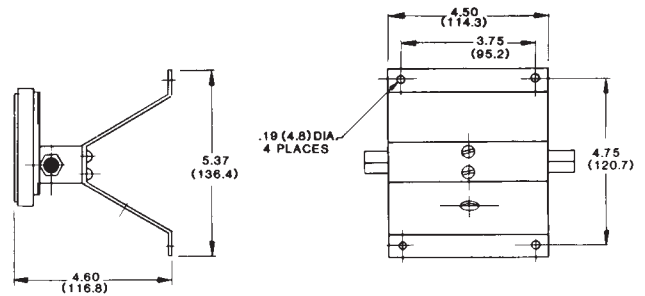

(Fig. 3)

- NOTES: 1. Drawings show standard gauge nominal dimensions. (not to scale)  
 2. Dimensions shown in parentheses are in millimeters.  
 3. Manufacturer reserves the right to change specifications without prior notice.

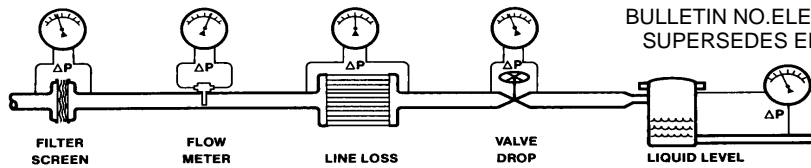

## Model 120 Electrical: Installation and Operating Instructions

### ELECTRICAL

Gauges with switches have one or two hermetically sealed adjustable set point reed switch assemblies. Load ratings and capabilities for each switch type are defined as follows:

#### REED SWITCH RATINGS (Resistive Load)

Type	SPST	SPDT	SPDT
Option:	E, F, G	H	A
*Power	60 W	60 W	3W
Max. Current	3.0 Amps	1.0 Amps	0.25 Amps
Max. Voltage VAC/VDC	240	240	125
**Setting (%F.S.)	25 to 95	25 to 100	10 to 90
Hysteresis (Max/Nom)	15% / 8% (F.S.)	20% / 13% (F.S.)	10% / 5% (F.S.)
Repeatability	1% F.S.	1% F.S.	1% F.S.
Leads 22 Awg.	(2), 24"	(3), 24"	(3), 24"

- \* Product of the switching voltage and current shall not exceed the power rating of the device.
- \*\* Except where otherwise noted

The SPDT switch ('A' or 'H' Electrical Option) lead colors and associated functionality at '0' PSID is shown in Figure 1. SPST switches ('E', 'F', or 'G' Electrical Options) may be normally closed or normally open at '0' PSID dependent upon the option specified on the purchase order.

All switch types are field adjustable. The defined range of the adjustment is specified in the table above. All switches come with a decal to identify adjustment direction to increase the set point. **Do not use excessive force when rotating the adjustment screw as the adjustment mechanism may be damaged. Also note the location of the screw adjust (See Figure 4.) Do not mistake it for the calibration adjust for the gauge.**

**Note:** Switches can be set below the defined minimum set point however, the switch may not remain activated at maximum PSID. If the unit is set below the defined minimum set point, the customer should verify that the switch remains activated from the set point to over range of the gauge.

Provide standard protection techniques for the switch contacts for capacitive and inductive loads. Use current limiting techniques near the switch to protect the contacts due to high inrush (i.e.; in line resistor or inductor) for long cable interfaces. Provide clamping devices at or near inductive loads (i.e.; relay). **Maximum wire length between the 3W switch and its load, should not exceed 70 – 100 Feet. for 120 VAC applications.** Contact the factory for assistance regarding this condition.

Use the Mid-West Power Relay 1000TR or equivalent relay for loads above the switch rating,.

**The following warnings apply to all gauge options with electrical interface:**

**WARNING: ELECTRICAL CONNECTIONS SHOULD**



**BE PERFORMED BY QUALIFIED PERSONNEL AND MEET THE REPRESENTATIVE COUNTRY'S NATIONAL ELECTRICAL CODE.**

**WARNING: FAILURE TO CONNECT TO THE PROTECTIVE CONDUCTOR TERMINAL MAY RESULT IN A SHOCK HAZARD.**

#### Grommet Wire / 1/4" FNPT Wiring Interface



The standard switch enclosure is weather resistant with 24" flying lead wire interface. A rubber grommet provides the seal around the wires (See Figure 2). (Options A & B)

The conduit version provides a NEMA 4X rated environmental seal with a 1/4" FNPT wiring interface in the rear center of the gauge body (See Figure 3).(Options C & D)

A provision to connect a protective conductor terminal is provided on the High port end of the gauge body. A 6-32 screw, 18 Awg, 24 " long, green/yellow wire, and a #6 terminal is provided.

Standard location of a SPDT switch will be on the bottom of the gauge for a standard port gauge. For a reverse port gauge the switch will be on top. (See Figure 2). SPDT Switch leads are color coded and labeled as follows:

**White-** 1 or 2 Com    **Black-** 1 or 2 NC    **Red -** 1 or 2 NO

Location for the SPST switch will vary depending on the switch type required. A standard port gauge has the normally open switch located on the bottom of the gauge body and the normally closed switch located on the top. This applies to both a single switch unit or a double switch unit with one of each type ("G" option Electrical Specifications).

A reverse port gauge has the normally open switch located on the top and the normally closed switch located on the bottom. Leads are labeled as follows:

Single Switch Unit:    1NC or 1NO  
Double Switch Units: 1NC or 1 NO and 2NC or 2NC

Deviations from the above configurations may exist. Therefore check the description block of your order to verify your configuration.

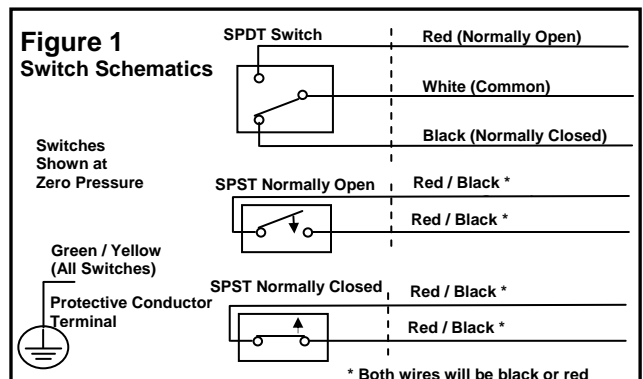

## DIN Plug-in Connector (Options L & M)



The DIN interface conforms to DIN 43 650A / ISO 4400 and **when mated** provides an IP65 rated protection class. The right angle mating connector is supplied with the gauge upon order. Clocking (orientation) can be changed by prying out the insert and rotating the insert to the desired clocking (90 ° increments). (See Figure 4)

Wiring for the SPDT bottom and top switch for the defined port configuration is as follows:

Standard Port - 1.- Common, 2. - N.C., 3. - N.O.  
Reverse Port - 1. - Common, 2. - N.O., 3. - N.C.

Wiring for the SPST switch is between terminals 1 & 2.

A protective conductor terminal is provided on the DIN connector. 

## NEMA 4X (Weatherproof Enclosure) (Options G & H)



The gauge and switch(es) are mounted inside the enclosure with the switch(es) wired to a seven (7) position terminal strip. The terminal strip connection uses 6-32 screws and is rated for use with wire up to 14 Awg.. An opening is provided on the bottom of the enclosure for a 1/2" flexible cable or conduit connection.

Access the terminal strip by removing the cover from the enclosure and loosening the (4) screws. Insert wires through an appropriate weatherproof connector (not supplied) into the enclosure and connect to the terminal strip. See the terminal strip diagram shown below or on the outside of the switch enclosure. Reinstall the cover and (4) screws (See Figures 5 & 6).

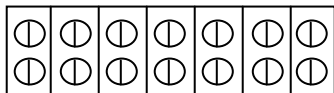

NO NC CM  CM NC NO  
SINGLE DOUBLE

Wiring to the terminal strip for SPST switches is defined by the functionality required. i.e.; a normally closed switch is wired between the CM and NC connections with the NO connection unused and a normally open switch is wired between the CM and NO connections with the NC connection unused.

Access holes and plugs are provided for external adjustment of the switches if required (Except Model 120 4 1/2" Dial). The cover for the Model 120 with 4 1/2" Dial must be removed to adjust the switch settings.

## NEMA 7 (Explosion-proof) Enclosure (Options J & K)



**WARNING: THE COVER AND/OR SWITCH ADJUST ACCESS PLUGS MUST NEVER BE REMOVED WHEN THERE IS POWER TO THE UNIT. MAKE ALL ADJUSTMENTS IN A NONHAZARDOUS AREA.**

The gauge and switches are mounted inside the enclosure (See Fig. 8). A 1/2"-14 FNPT conduit connection is provided in the bottom side of the enclosure. A proper explosion proof, dust tight, sealing fitting with appropriate sealing cement must be used when making connections to the 24", 18 Awg. wire leads. The leads are labeled and/or color coded as described in the grommet / conduit section.

Adjustment of the set point can be accomplished by removing the switch adjustment access plug(s). Insert the screw driver through the hole into the switch adjustment slot and rotate until the desired set point is reached. **Do not use excessive force. Reinstall the access plugs with at least 5 threads of engagement after completion.**

Enclosures with SPDT or SPST switches comply with NEC Class 1, Groups C & D; Class 2 Groups E,F, & G, NEMA 7 and 9. All switches are CSA / NRTL listed.

## Division II Hazardous Ratings (Options E & F):



The E & F Electrical Configuration are 3<sup>RD</sup> party certified for **Class I, Division II, Groups A, B, C, & D, Class II, Groups F & G** hazardous environments. The CSA mark identifies the product has been tested to the applicable **US standards** and the applicable Canadian standards.

Interface is 24", 18 Awg. flying leads with 1/2" FNPT Conduit. (See Figure 7)

## MISCELLANEOUS

### Bi-directional Dial:

SPDT Switch units, with the bi-directional dial, require the following setting instructions:

1. If the switch is to operate for positive  $\Delta P$ , rotate the adjusting screw Counter Clockwise (Red - NO, Black- NC, White- Common).
2. If the switch is to operate for negative  $\Delta P$ , rotate the adjusting screw Clockwise (Red- NC, Black- NO, White -Common)

The functionality of SPST switches will be reversed for negative  $\Delta P$  and positive  $\Delta P$ . i.e.; a normally open switch (B option), will switch from open to closed for set points above 0 PSID, but will switch from closed to open for set points below 0 PSID.

## TROUBLE SHOOTING

### A. Switch doesn't function

- i. Make sure that the switch load does not exceed the specified wattage rating of the switch. (steady-state and transient). Contact factory for assistance for excessive loads, otherwise proceed to the next step.
- ii. Perform a continuity check of the switch contacts by trying to actuate the switch using an external magnet. An operational switch usually indicates a problem with the gauge. If not operational proceed to the next step.
- iii. Verify the reed switch wires are connected to the terminal strip (NEMA 4X enclosure only). Contact the factory for assistance if the switch is connected and/or request an "RGA" number.

### C. Gauge accuracy and set point problems:

- i. Verify gauge is not in an electromagnetic / magnetic environment. i.e.; close proximity to high current power lines.
- ii. All others, contact the factory for assistance.

# MOUNTING INFORMATION & DIMENSIONAL DATA

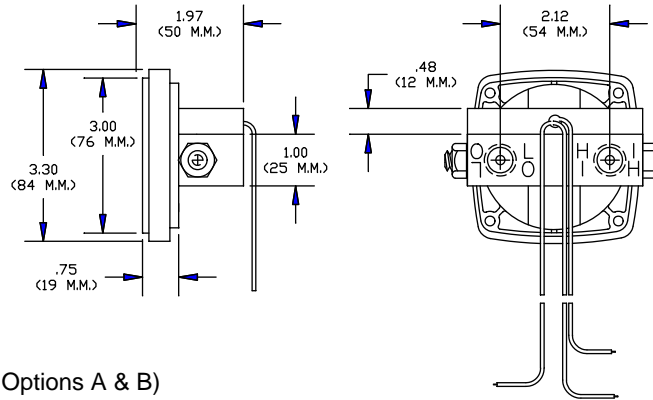
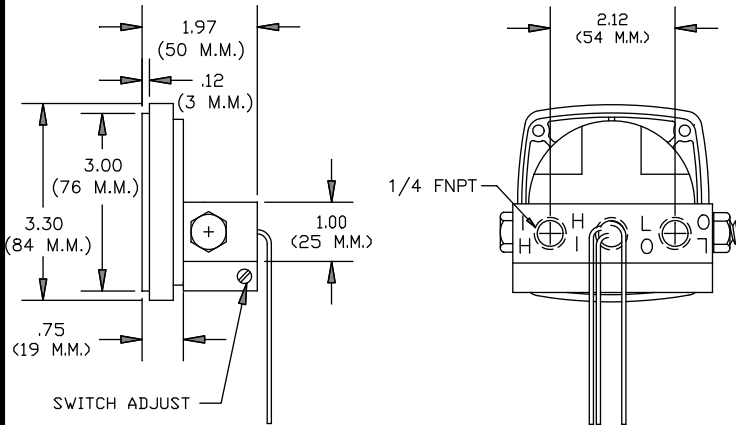

**FIGURE 2**

Model 120 Reverse Port  
Grommet Interface Switch Options A & B)

**NOT SHOWN: (Fig 2 & 3)**

The Protective Conductor Terminal with a Green / Yellow Wire located on the High Port end of the gauge body.



**FIGURE 3**

Model 120 Standard Port  
1/4" FNPT Interface Switch (Options C & D)

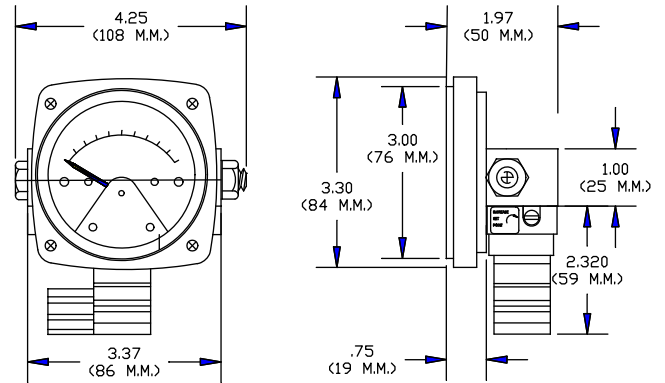

**FIGURE 4**

Model 120 Reverse Port  
Din Connector Interface  
Switch (Options L & M)

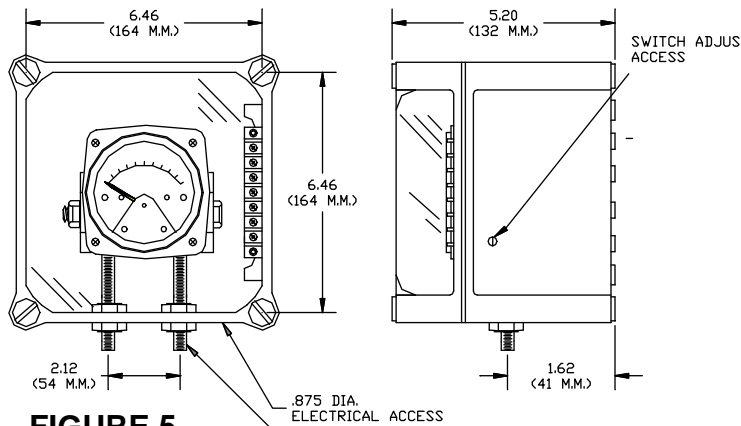

**FIGURE 5**

Model 120 2 1/2 Dial  
NEMA 4 X (Options G & H)

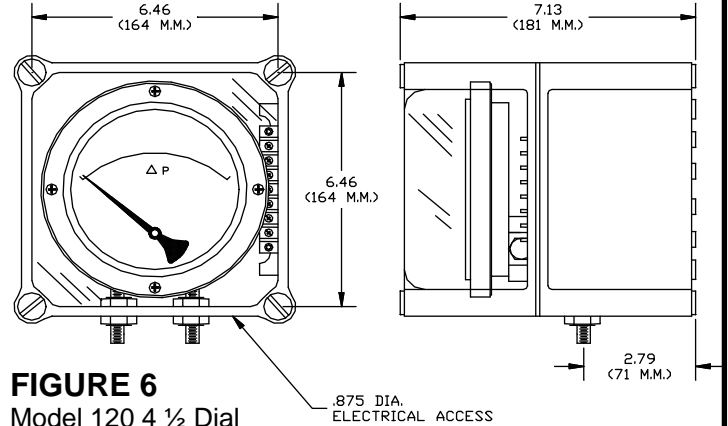

**FIGURE 6**

Model 120 4 1/2 Dial  
NEMA 4 X (Options G & H)

**FIGURE 7**

Model 120 2 1/2 Dial Options (E & F)

Hazardous Locations,  
Division II, Class I,  
Groups A, B, C, D  
Class II Groups F & G  
(CSA Listed for all switch  
specifications)

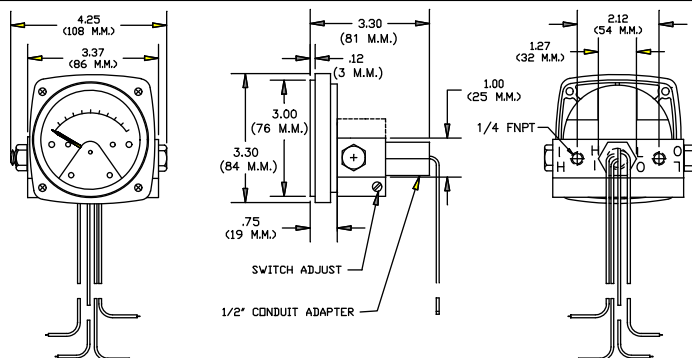
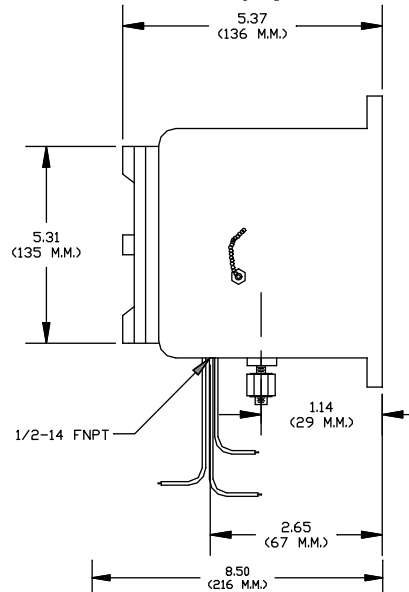
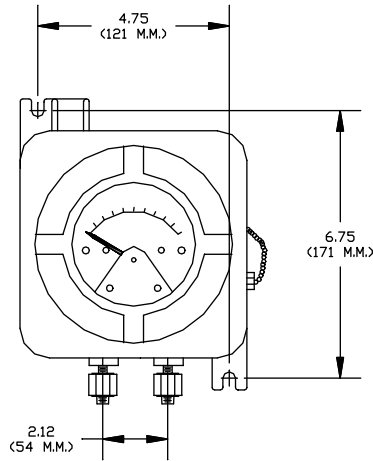

**FIGURE 8**

**Explosion-Proof Enclosures Class I, Groups C & D,  
Class II, Groups E, F, & G  
(Options J & K)**



**2 1/2 Inch  
Dial**



**4 1/2 Inch  
Dial**

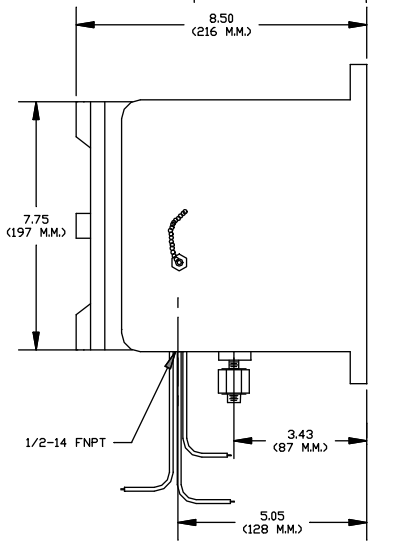
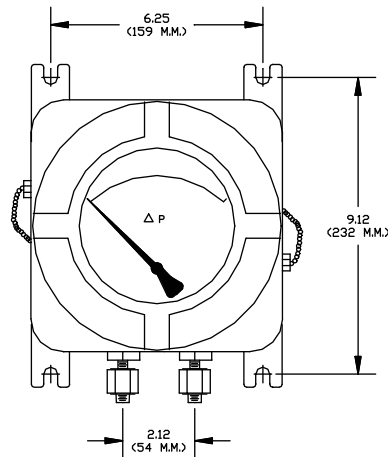

**Typical 2" Pipe  
Mounting**

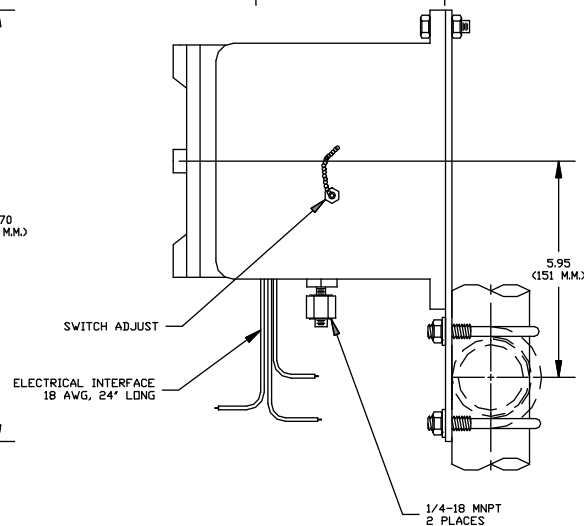
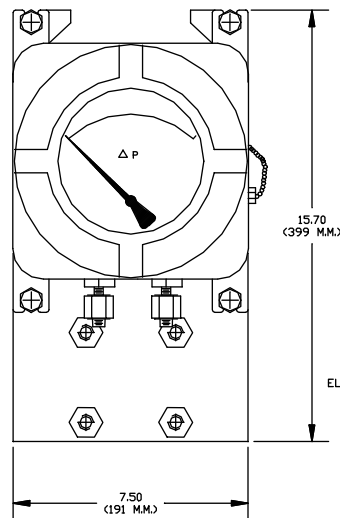

**Mid-West<sup>®</sup>  
Instrument**

6500 Dobry Dr. Sterling Heights, MI 48314  
(586)254-6500 FAX (586)254-6509  
E-Mail: [sales@midwestinstrument.com](mailto:sales@midwestinstrument.com)  
Web Page: [www.midwestinstrument.com](http://www.midwestinstrument.com)

**Warning: The suitability of the application and installation of this differential pressure switch is the responsibility of the end user. The applicable certifications, listings apply to the differential pressure switch only.**