

Installation & Maintenance Instructions

MODEL R82

NON CONTACT RADAR TRANSMITTER

Registered Address

ABLE Instruments & Controls Ltd
Cutbush Park, Danehill, Lower Earley,
Reading, Berkshire, RG6 4UT. UK.

Reading

Tel: +44 (0)118 9311188 | Email: info@able.co.uk

Aberdeen

Tel: +44 (0)1224 725999 | Email: ab@able.co.uk

Web

able.co.uk

E-commerce

247able.com



Model R82

R82 software v2.0a

Installation and Operating Manual

*Pulse Burst Radar
Level Transmitter*



Read this Manual Before Installing

This manual provides information on the R82 Radar transmitter. It is important that all instructions are read carefully and followed in sequence. The *QuickStart Installation* instructions are a brief guide to the sequence of steps for experienced technicians to follow when installing the equipment. Detailed instructions are included in the *Complete Installation* section of this manual.

Conventions Used in this Manual

Certain conventions are used in this manual to convey specific types of information. General technical material, support data, and safety information are presented in narrative form. The following styles are used for notes, cautions, and warnings.

NOTES

Notes contain information that augments or clarifies an operating step. Notes do not normally contain actions. They follow the procedural steps to which they refer.

Cautions

Cautions alert the technician to special conditions that could injure personnel, damage equipment, or reduce a component's mechanical integrity. Cautions are also used to alert the technician to unsafe practices or the need for special protective equipment or specific materials. In this manual, a caution box indicates a potentially hazardous situation which, if not avoided, may result in minor or moderate injury.

WARNINGS

Warnings identify potentially dangerous situations or serious hazards. In this manual, a warning indicates an imminently hazardous situation which, if not avoided, could result in serious injury or death.

Safety Messages

The Through-Air Radar system is designed for use in Category II, Pollution Degree 2 installations. Follow all standard industry procedures for servicing electrical and computer equipment when working with or around high voltage. Always shut off the power supply before touching any components. Although high voltage is not present in this system, it may be present in other systems.

Electrical components are sensitive to electrostatic discharge. To prevent equipment damage, observe safety procedures when working with electrostatic sensitive components.

Low Voltage Directive

For use in Installations Category II, Pollution Degree 2. If equipment is used in a manner not specified by the manufacturer, protection provided by equipment may be impaired.

NOTE: This equipment has been tested and found to comply with the limits for a Class B digital device, pursuant to Part 15 of the FCC Rules. These limits are designed to provide reasonable protection against harmful interference in a residential installation. This equipment generates, uses and can radiate radio frequency energy and, if not installed and used in accordance with the instructions, may cause harmful interference to radio communications. However, there is no guarantee that interference will not occur in a particular installation. If this equipment does cause harmful interference to the

radio or television reception, which can be determined by turning the equipment off and on, the use is encouraged to try to correct the interference by one or more of the following measures:

- Reorient or relocate the receiving antenna.
- Increase the separation between the equipment and receiver.
- Connect the equipment into an outlet on a circuit different from that to which the receiver is connected.
- Consult the dealer or an experienced radio/TV technician for help.

Any unauthorized changes or modifications not expressly approved by Magnetrol® International, Incorporated could void user's authority to operate this equipment.

WARNING! Explosion hazard. Do not connect or disconnect designs rated Explosion-proof or Non-incendive unless power has been switched off and/or the area is known to be non-hazardous

Notice of Copyright and Limitations

MAGNETROL & MAGNETROL logotype are registered trademarks of MAGNETROL INTERNATIONAL.

Copyright © 2019 MAGNETROL INTERNATIONAL, INCORPORATED
All rights reserved.

Performance specifications are effective with date of issue and are subject to change without notice. MAGNETROL reserves the right to make changes to the product described in this manual at any time without notice. MAGNETROL makes no warranty with respect to the accuracy of the information in this manual.

Warranty

All MAGNETROL electronic level and flow controls are warranted free of defects in materials or workmanship for eighteen months from the date of original factory shipment.

If returned within the warranty period; and, upon factory inspection of the control, the cause of the claim is determined to be covered under the warranty; then, MAGNETROL will repair or replace the control at no cost to the purchaser (or owner) other than transportation.

MAGNETROL shall not be liable for misapplication, labor claims, direct or consequential damage or expense arising from the installation or use of equipment. There are no other warranties expressed or implied, except special written warranties covering some MAGNETROL products.

Quality Assurance

The quality assurance system in place at MAGNETROL guarantees the highest level of quality throughout the company. MAGNETROL is committed to providing full customer satisfaction both in quality products and quality service.

The MAGNETROL quality assurance system is registered to ISO 9001 affirming its commitment to known international quality standards providing the strongest assurance of product/service quality available.



Model R82 Pulse Burst Radar Level Transmitter

Table of Contents

1.0 QuickStart Installation	
1.1 Getting Started.....	4
1.1.1 Equipment and Tools	4
1.1.2 Configuration Information.....	5
1.2 QuickStart Mounting.....	6
1.2.1 Transmitter/Antenna	6
1.3 QuickStart Wiring	6
1.4 QuickStart Configuration	7
2.0 Complete Installation	
2.1 Unpacking	9
2.2 Electronic Discharge (ESD) Handling Procedure.....	9
2.3 Before You Begin.....	10
2.3.1 Site Preparation	10
2.3.2 Equipment and Tools	10
2.3.3 Operational Considerations.....	10
2.3.3.1 Maximum Distance.....	10
2.3.3.2 Minimum Distance.....	10
2.3.3.3 Problematic Applications; GWR Alternative	11
2.4 Mounting.....	12
2.4.1 Installing the Transmitter	12
2.4.1.1 Location.....	12
2.4.1.2 Beam Angle.....	12
2.4.1.3 Obstructions	13
2.4.1.4 Nozzles.....	13
2.4.1.5 Stillwells.....	14
2.4.1.6 Open Channel Flow Measurement	14
2.4.2 Installing the Transmitter	15
2.4.2.1 Orientation	15
2.4.2.2 Launcher Orientation— Level Application	15
2.4.2.3 Launcher Orientation in Flow Application.....	16
2.4.2.4 Poor Echo Strength	16
2.5 Wiring	17
2.5.1 General Purpose or Non-Incendive	17
2.5.2 Intrinsically Safe.....	17
2.6 Configuring the Transmitter.....	18
2.6.1 Operating Parameters	18
2.6.2 Setting Up for Shop Configuration	18
2.6.3 Transmitter Display and Keypad	18
2.6.4 Menu Traversal and Data Entry.....	19
2.6.4.1 Navigating Menu	19
2.6.4.2 Data Selection	19
2.6.4.3 Entering Numeric Data Using Digit Entry.....	19
2.6.4.4 Entering Numeric Data Using Increment/Decrement	20
2.6.4.5 Entering Character Data	20
2.6.5 Password Protection (Default = 0).....	21
2.6.6 Menu: Step-By-Step Procedure.....	21
2.6.6.1 Radar Transmitter User Menu— Level Measurement Only	22
2.6.6.2 Radar Transmitter User Menu— Volume and Level	26
2.6.6.3 Radar Transmitter User Menu— Flow and Level.....	32
2.6.6.4 Radar Transmitter Factory Menu	40
2.7 Configuration Using HART®	41
2.7.1 Connections	41
2.7.2 Display Menu.....	41
2.7.3 Model R82 HART Revision Table	41
2.7.4 HART Menu – Level Only	42
2.7.5 HART Menu – Volume & Level and Flow & Level.....	44
3.0 Reference Information	
3.1 Description	46
3.2 Theory of Operation.....	46
3.2.1 Pulse Burst Radar	46
3.2.2 Equivalent Time Sampling	47
3.3 Troubleshooting	48
3.3.1 Troubleshooting System Problems.....	48
3.3.2 Error Messages	49
3.4 Agency Approvals.....	52
3.4.1 Agency Drawing and Entity Parameters	53
3.5 Parts	54
3.5.1 Replacement Parts	54
3.5.2 Recommended Spare Parts	54
3.6 Specifications	55
3.6.1 Functional – Transmitter	55
3.6.2 Performance	56
3.6.3 Functional	57
3.6.4 Antenna Pressure/Temperature Ratings	57
3.6.5 Physical	58
3.7 Model Numbers.....	59
3.7.1 Model R82 Radar Transmitter.....	59
Glossary	60
Model R82 Configuration Data Sheet	63

1.0 QuickStart Installation

The QuickStart Installation procedures provide the key steps for mounting, wiring, and configuring the R82 radar level transmitter. These procedures are intended for experienced installers of electronic level measurement instruments. See Complete Installation, Section 2.0, for detailed installation instructions.

1.1 Getting Started

Before beginning the QuickStart Installation procedures, have the right equipment, tools, and information available.

1.1.1 Equipment and Tools

No special tools are needed. The following items are recommended:

- Threaded antenna and transmitter 2" (50 mm)
- Flat-blade screwdriver
- Digital multimeter or volt/ammeter Optional
- 24 VDC (23 mA) power supply. Optional

1.1.2 Configuration Information

Some key information is needed to configure the R82 radar transmitter. Complete the following operating parameters table before beginning configuration. Refer to Section 2.4.1.6 for Open Channel Flow applications.

Display	Question	Answer
Units	What units of measurement will be used?	
	Will the unit measure in Level or Volume?	
	What are the Volume units?	
	What is the relationship between Level and Volume? (Enter up to 20 points)	
Sensor Offset	What is the distance from the top (100%) of the tank and the Sensor Reference point? (bottom of NPT thread, top of BSP thread, or face of flange?)	
Tank Top	Is the Tank Top: Flat, Horizontal Cylinder, Dome, Irregular or Other (non-metallic)?	
Tank Height	What is the tank height? NOTE: $Sensor\ Offset + Tank\ Height = Distance\ from\ process\ connection\ to\ tank\ bottom.$	
Blocking Distance	Default of 15" (375 mm) is the minimum distance from the process connection to the maximum level. Extend this value when necessary to block reflections from objects close to the antenna.	
Level Offset	Is there a region at the very bottom of the vessel that cannot be measured due to heating coils, angle tank bottom, etc.?	
Dielectric	What is the dielectric of the process medium?	
Turbulence	Is turbulence a consideration?	
Foam	Will there be foam on the surface?	
Rate of Change	What is the maximum rate the level will rise or fall?	
4.0 mA Setpoint	What is the 0% reference point for the 4.0 mA value?	
20.0 mA Setpoint	What is the 100% reference point for the the 20.0 mA value?	

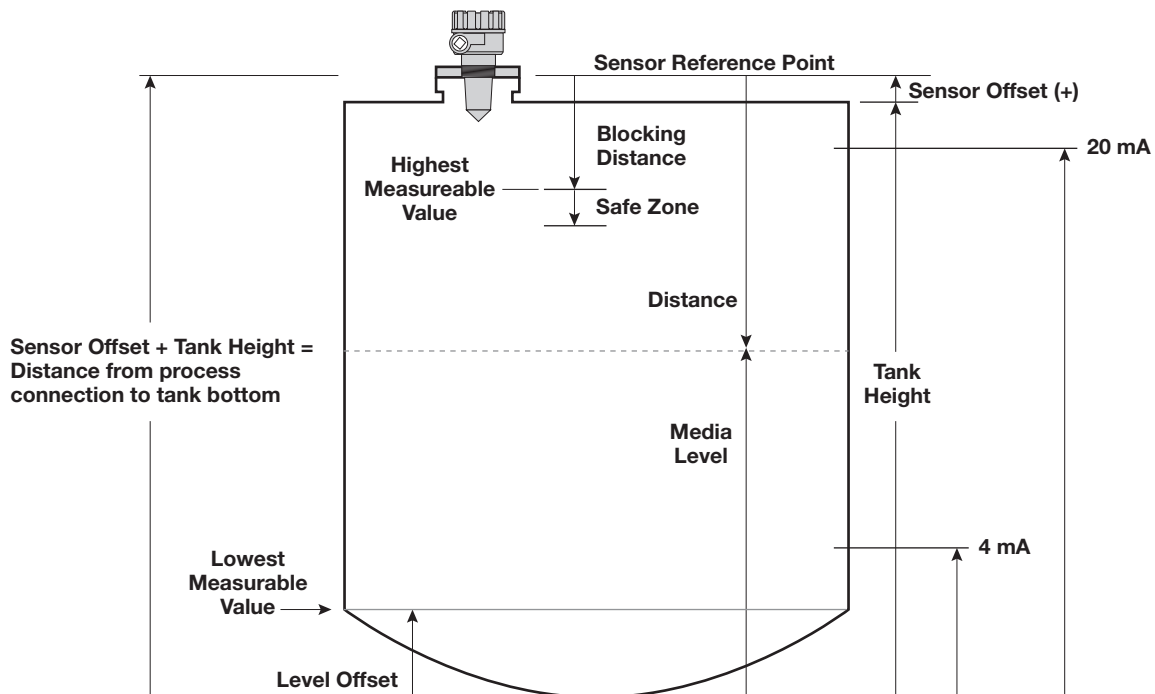

Figure 1

1.2 QuickStart Mounting

1.2.1 Transmitter/Antenna

1. The device is manufactured as one unit that includes the transmitter and antenna.
2. Remove any protective material from the antenna before installing.
3. Install the transmitter/antenna into the process connection. If threaded, tighten securely by hand using the housing for grip. Ensure there is no cross-threading and do not over tighten as this may cause damage to the plastic threads.
4. Adjust the beam position by turning the internal launcher adjustment (Figure 2). The internal launcher adjustment is numbered 1-18 that equates to 10-180 degrees of adjustment; 9 is the midpoint. The polarization pattern is parallel to the transmitter display when the adjustment mechanism is in the #11 position (factory default). After positioning the transmitter display, the launcher should be adjusted so the polarization pattern is parallel to a line tangent to the nearest tank wall (Figure 3). Do not optimize the Echo Strength at one level in the vessel.
 - Do not place insulating material around any part of the Radar transmitter including the antenna process connection.

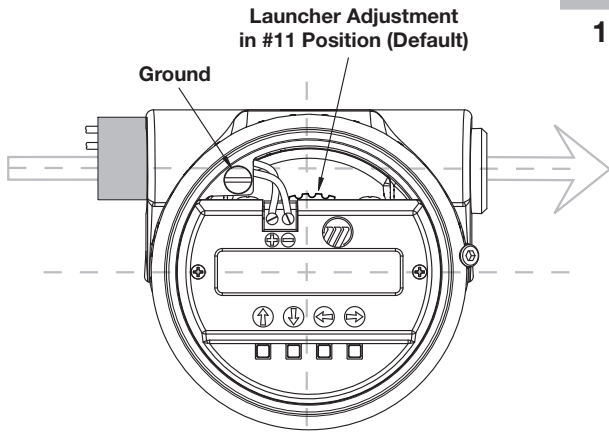

Figure 2

Polarization pattern when launcher is in the #11 Position (default)

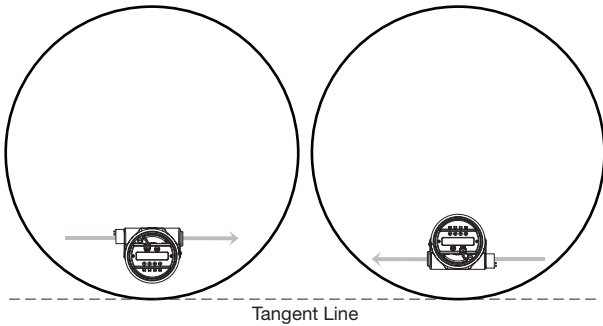

Figure 3

Polarization shown parallel to tangent line; either orientation is acceptable

1.3 QuickStart Wiring

NOTE: Make sure the electrical wiring to the R82 radar transmitter is complete and in compliance with all regulations and codes.

1. Remove the cover of the wiring compartment.
2. Attach a conduit fitting and mount the conduit plug in the spare opening. Pull the power supply wire through the conduit fitting.
3. Connect shield to an earth ground at power supply and leave floating at the transmitter.
4. Connect the positive supply wire to the (+) terminal and the negative supply wire to the (-) terminal.
5. Seal conduit to prevent ingress of moisture.
6. Replace cover of the transmitter.

1.4 QuickStart Configuration

The Radar transmitter comes factory-calibrated and can be configured in minutes for specific applications. Bench configuration provides a convenient and efficient way to set up the transmitter before going to the tank site to complete the installation. The minimum configuration instructions follow. Use the information from the operating parameters table before beginning configuration. See Configuration Information, Section 1.1.2.

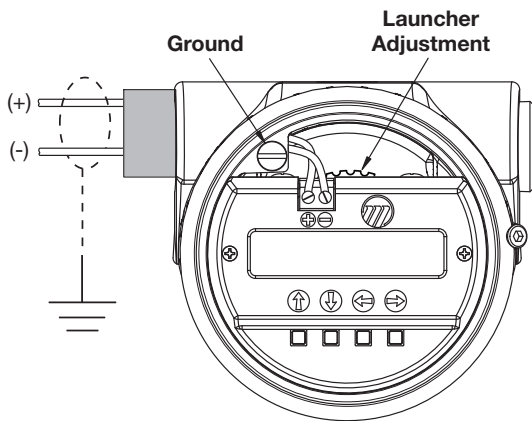

Figure 4

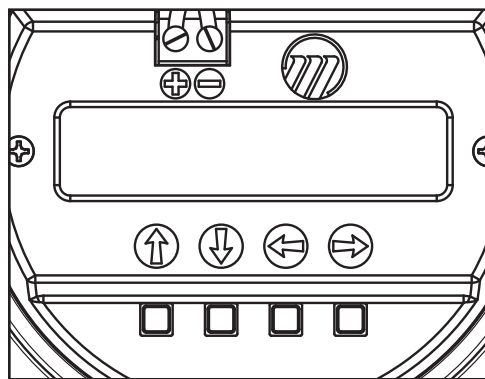

Figure 5

1. Power-up the transmitter.
During normal operation the display changes every 2 seconds to show one of the various measured values that can be chosen for display: Level, Volume, Distance, Echo Strength, %Output, Loop Current and Local Tag.
2. Remove the cover of the electronic compartment.
3. The push buttons offer multiple forms of functionality for menu navigation and data entry. (See Section 2.6.3 for complete explanation)
 - ⬆ UP arrow moves up through menu or increases displayed value
 - ⬇ DOWN arrow moves down through menu or decreases displayed value
 - ⬅ BACK arrow exits a branch of the menu or exits without accepting entered value
 - ➡ ENTER arrow enters a branch of the menu or accepts entered value

If a PASSWORD is requested, enter it now. The Default=0 (no password necessary).

The following configuration entries are the minimum required for configuration. The default password is 0 (no password necessary).

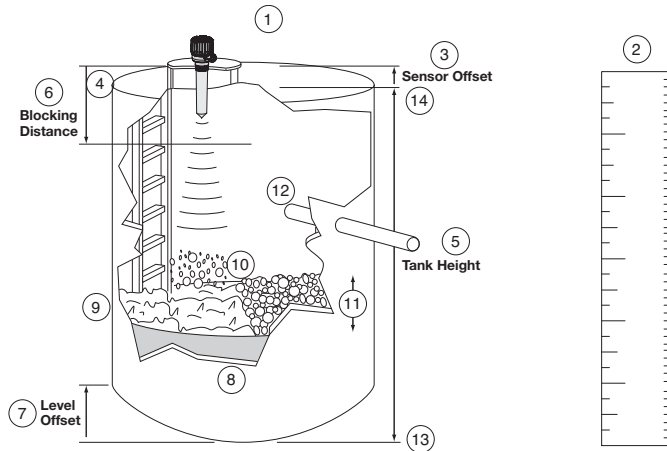

Figure 6

- | | | | | | |
|---|-----------------------|---|----|-------------------------|--|
| 1 | Measure Type | Select if Level or Level & Volume | 8 | Dielectric (select) | Select the proper Dielectric range for the process medium. |
| 2 | Level Units (select) | Select the Units of measure for the display (cm, inches, meters, feet). | 9 | Turbulence (select) | Select the value of Turbulence that corresponds to the application. |
| 3 | Sensor Offset
xxxx | Enter the Sensor Offset value; the distance from the top of the vessel to the Sensor Reference point (bottom of an NPT thread, top of a BSP thread, face of a flange). | 10 | Foam (select) | Select the Foam value that corresponds to the application. |
| 4 | Tank Top (select) | Select the type of Tank Top ; choices are Flat, Horizontal cylinder, Dome, Irregular, or Other (nonmetallic). | 11 | Rate of Change (select) | Select the Rate of Change value that corresponds to the maximum rate the level will rise or fall. |
| 5 | Tank Height
xxxx | Enter the exact Tank Height ; inaccurate values will create inaccurate level readings. | 12 | Echo Profile | Examine the list of reflections detected by the transmitter to ensure the actual level reflection is present. It may be necessary to rotate the launcher for optimal performance. Run the Echo Rejection routine by choosing the correct LEVEL thereby cancelling all false reflections in the vessel; ideally with tank empty. |
| 6 | Blocking Dist
xxxx | Enter the Blocking Distance ; the distance close to the antenna where measurement is unreliable. Minimum value = 15" (375 mm) as measured from the process connection. | 13 | Set 4mA
xx.x | Enter the minimum level value (0%) for the 4 mA point. |
| 7 | Level Offset
xxx.x | Enter the Level Offset ; the distance at the bottom of the vessel where measurement may be unreliable due to heating coils, irregular bottom, etc. | 14 | Set 20mA
xx.x | Enter the maximum level (100%) for the 20 mA point. |

2.0 Complete Installation

This section provides detailed procedures for properly installing, configuring, and, as needed, troubleshooting the R82 Radar Level Transmitter.

2.1 Unpacking

Unpack the instrument carefully. Make sure all components have been removed from the packing material. Check all the contents against the packing slip and report any discrepancies to the factory.

Before proceeding with the installation, do the following:

- Inspect all components for damage. Report any damage to the carrier within 24 hours.
- Make sure the nameplate model number on the transmitter agree with the packing slip and purchase order.
- Record the model and serial numbers for future reference when ordering parts.

2.2 Electrostatic Discharge (ESD) Handling Procedure

The MAGNETROL electronic instruments are manufactured to the highest quality standards. These instruments use electronic components that may be damaged by static electricity present in most work environments.

The following steps are recommended to reduce the risk of component failure due to electrostatic discharge.

- Ship and store circuit boards in anti-static bags. If an anti-static bag is not available, wrap the board in aluminum foil. Do not place boards on foam packing materials.
- Use a grounding wrist strap when installing and removing circuit boards. A grounded workstation is recommended.
- Handle circuit boards only by the edges. Do not touch components or connector pins.
- Make sure that all electrical connections are completely made and none are partial or floating. Ground all equipment to a good, earth ground.

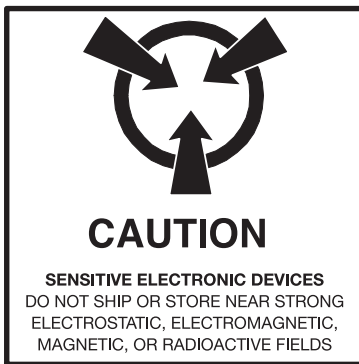

2.3 Before You Begin

2.3.1 Site Preparation

Each R82 Radar transmitter is built to match the physical specifications of the required installation. Make sure the antenna connection is correct for the threaded or flanged mounting on the vessel or tank where the transmitter will be placed. See Mounting, Section 2.4.

Make sure that the wiring between the power supply and Radar transmitter are complete and correct for the type of installation.

When installing the Radar transmitter in a general purpose or hazardous area, all local, state, and federal regulations and guidelines must be observed. See Wiring, Section 2.5.

2.3.2 Equipment and Tools

No special tools are needed. The following items are recommended:

- Threaded antenna and transmitter 2" (50 mm)
- Flat-blade screwdriver
- Digital multimeter or volt/ammeter Optional
- 24 VDC (23 mA) power supply. Optional

2.3.3 Operational Considerations

Radar applications are characterized by three basic conditions; Dielectric, Distance (measuring range) and Disturbances (turbulence, foam, false targets, multiple reflections and rate of change).

MAXIMUM DISTANCE feet (meters)

Dielectric	Turbulence	R82
1.7-3.0	None	26 (8.0)
	Light, < 0.5"	21 (6.4)
	Moderate, < 1.0"	14 (4.3)
	Heavy, > 1.0"	7 (2.1)
3.0-10.0	None	33 (10.1)
	Light, < 0.5"	26 (7.9)
	Moderate, < 1.0"	19 (5.8)
	Heavy, > 1.0"	12 (3.7)
10.0-100	None	40 (12)
	Light, < 0.5"	32 (9.8)
	Moderate, < 1.0"	24 (7.3)
	Heavy, > 1.0"	17 (5.2)

2.3.3.1 Maximum Distance

Figure 7 at left shows the maximum measuring range (Distance) based on fundamental conditions of Dielectric, Distance and Turbulence. Maximum distance is calculated as Tank Height + Sensor Offset. It is measured from the Sensor Reference Point (bottom of NPT thread, top of BSP thread or face of a flange).

2.3.3.2 Minimum Distance

If the liquid level is allowed onto the antenna, noise and media build-up drastically decrease reliable measurement. Liquid should not be allowed closer than 15" (380 mm), BSP: 16" (405 mm) from the bottom of the antenna mounting threads (or face of hygienic flange). The distance from the end of the antenna varies depending on antenna chosen. See Figure 8.

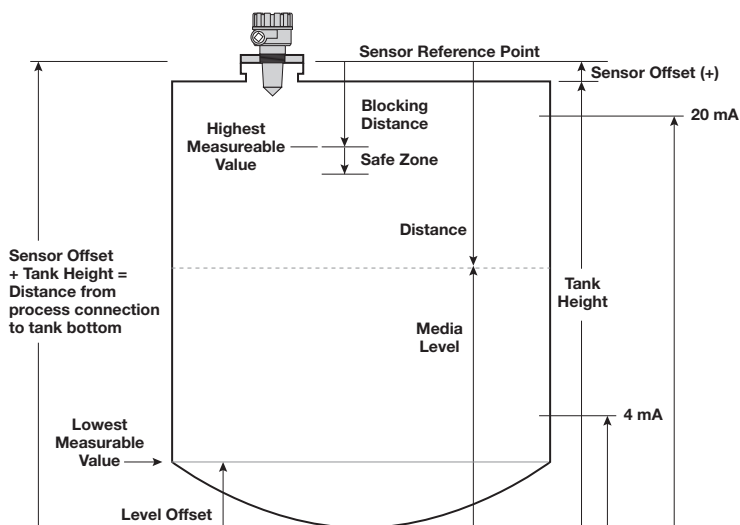

Figure 7

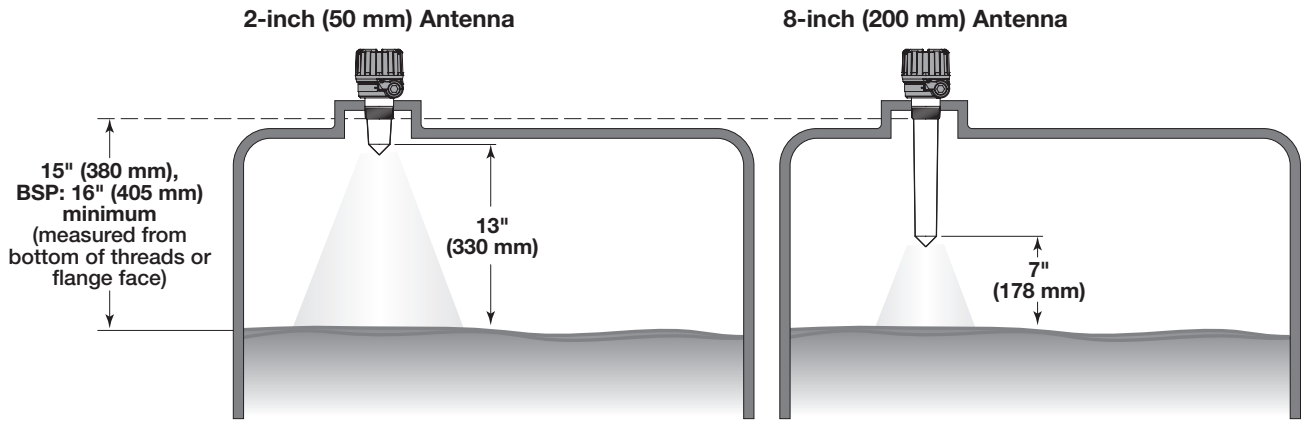

Figure 8

Minimum distance to end of antenna varies depending on antenna used

Maximum Recess (m) is $2 \times$ Nozzle Diameter (d) (Schedule 40 maximum)

(example: 2" diameter nozzle)

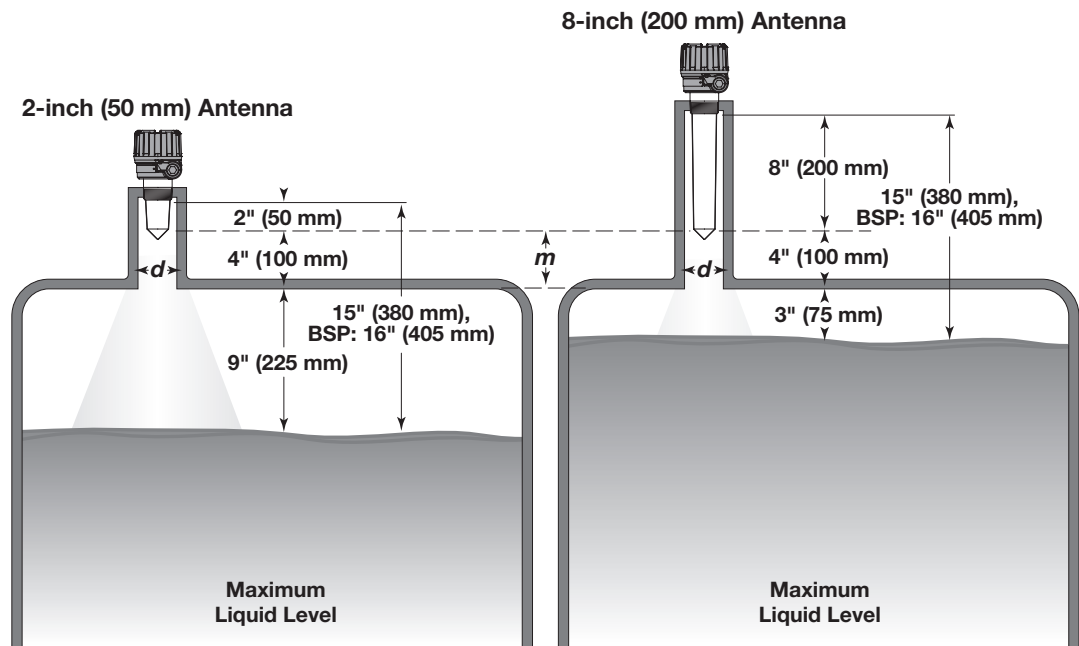

Figure 9

Using nozzle height to maximize useable tank space

2.3.3.3 Problematic Applications; GWR Alternative

Some application concerns can be problematic for Radar. For these, Guided Wave Radar is recommended:

- Extremely low dielectric media ($\epsilon_r < 2.0$)
- Very weak reflections from the liquid surface, particularly during turbulence, can cause poor performance.
- Tanks heavily cluttered with false targets (mixers, pumps, ladders, pipes, etc.)
- During times of very low liquid levels of low dielectric media, the metal tank bottom may be detected deteriorating performance.

- Foam can either absorb or reflect the microwave energy depending upon the depth, dielectric, density and wall thickness of the bubbles. Due to typical variations in the amount (depth) of foam, it is impossible to quantify performance. It may be possible to receive most, some or none of the transmitted energy.
- Extremely high liquid levels (Overflow) conditions when liquid very near the antenna (above the Blocking Distance) can cause erroneous readings and measurement failure.

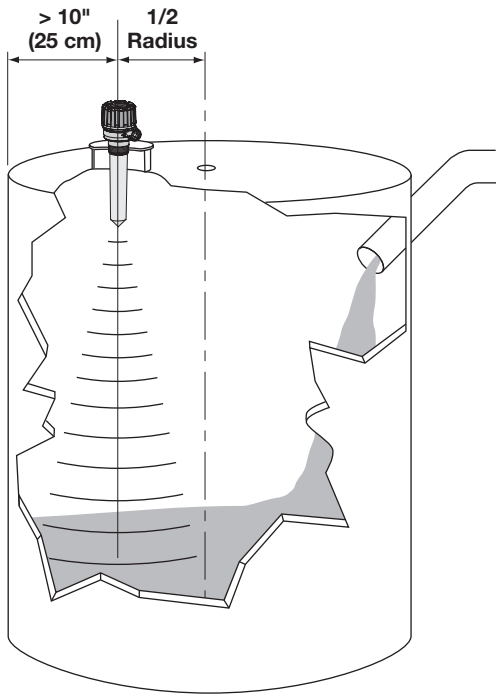
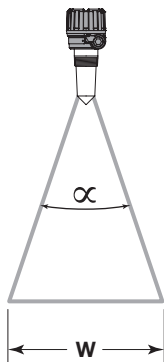

Figure 10



Distance		Beam Spread	
Feet	Meters	Feet	Meters
10	3	2.5	0.74
20	6	4.9	1.47
30	9	7.4	2.21
40	12	9.8	2.95

Figure 11

2.4 Mounting

The R82 Radar transmitter can be mounted to a vessel using a variety of process connections. Generally, either a threaded or flanged connection is used.

2.4.1 Installing the Transmitter

Before installing, make sure:

- Process temperature, pressure, dielectric, turbulence and distance are within the antenna specifications for the installation.
- End of antenna is protected from bending or breaking.
- Insulating material is not placed around any part of the Radar transmitter including the antenna flange.
- Transmitter is being mounted in the optimal location. See following sections: Location, Beam Angle, Obstructions, Nozzles, Stillwells, and Open Channel Flow for specific information.

2.4.1.1 Location

Ideally, the Radar transmitter should be mounted providing an unobstructed signal path to the liquid surface where it should illuminate (with microwave energy) the largest, possible surface area. See Section 2.4.1.2, Beam Angle. Unavoidable obstacles will produce reflections that must be minimized during field configuration. Mount in a location equal to $\frac{1}{2}$ the radius of tank top. Do not mount in center of vessel nor closer than 10" (25 cm) from the tank wall.

2.4.1.2 Beam Angle

Ideally, the beam pattern should illuminate the maximum liquid surface with a minimum striking other objects in the vessel including the tank wall.

2.4.1.3 Obstructions

Almost any object that falls within the beam pattern will cause reflections that may be misinterpreted as a false liquid level. Although Model R82 has a powerful Echo Rejection routine, all possible precautions should be taken to minimize false target reflections with proper installation and orientation. See Figure 12.

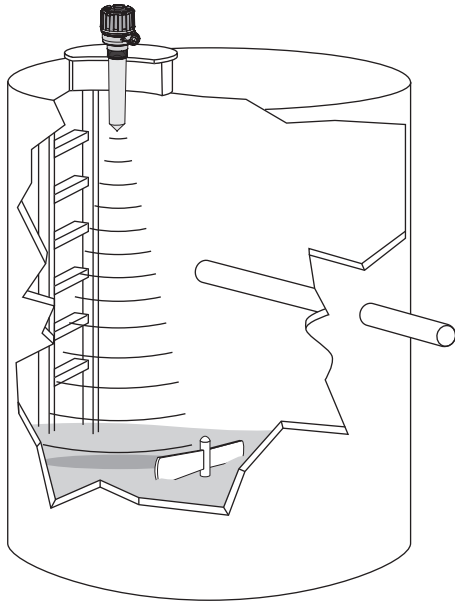

Figure 12
Avoiding Obstructions

2.4.1.4 Nozzles

Improper installation in a nozzle creates “ringing” which will adversely affect measurement. Two Antenna extension lengths are offered to allow the R82 transmitter to work reliably in a variety of nozzles.

The Minimum Blocking Distance of 15" (380 mm) is always measured from the bottom of the threads or face of the flange. The related distance as measured from the end of the antenna varies depending on the antenna extension chosen. See Figure 13.

The narrow beam width of the 26 GHz, R82 does allow mounting so that the antenna can be recessed inside the nozzle. Optimally, the recessed dimension should never exceed **2× the nozzle diameter** (Schedule 40 maximum). See Figure 13.

NOTE: If the antenna is recessed in a nozzle it is mandatory that Echo Rejection is run to eliminate any possibility of false reflections.

Maximum Recess (m) is $2 \times$ Nozzle Diameter (d) (Schedule 40 maximum)

(example: 2" diameter nozzle)

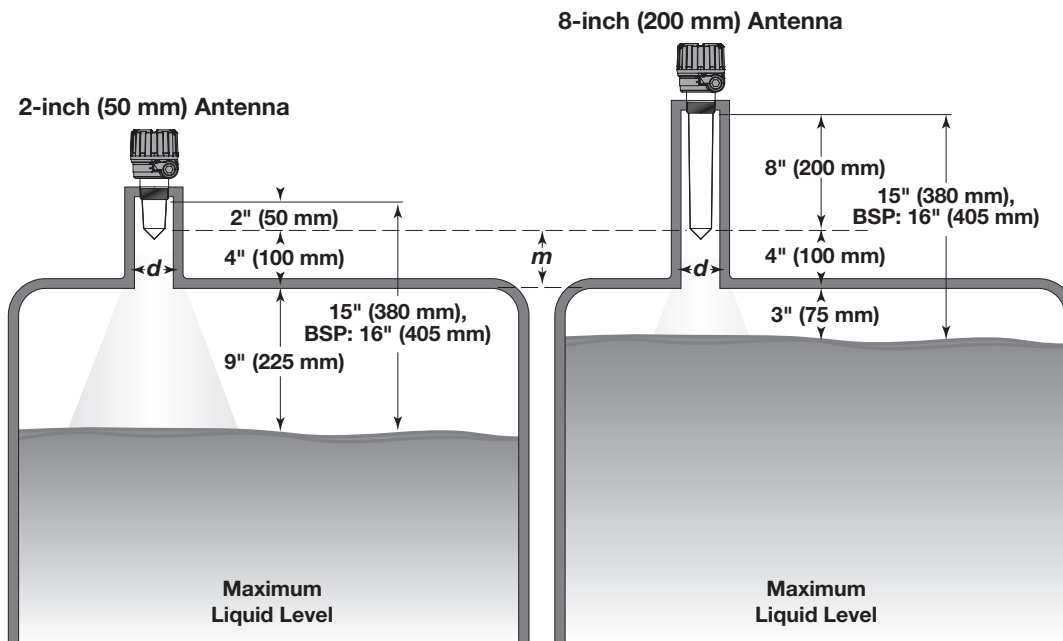

Figure 13
Using nozzle height to maximize useable tank space

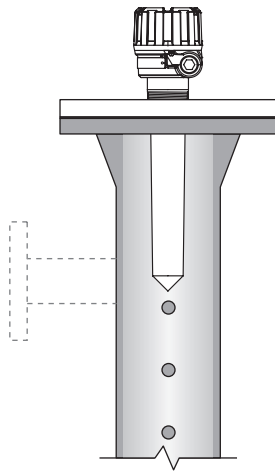

Figure 14
R82 Mounted in Stillwell (Bridle)

2.4.1.5 Stillwells

The R82 can be mounted in a stillwell but certain considerations should be given:

- Metal stillwells only: 2" (50 mm) Sched 40 max.
- Diameter must be consistent throughout length; no reducers.
- Stillwell length must cover complete range of measurement (i.e., liquid must be in stillwell).
- Welds should be smooth.
- Vents: holes <0.125" diameter, slots <0.125" width.
- If an isolation valve is used, it must be a full port ball valve with an I.D. equal to the pipe diameter.
- Bridles/Bypass Installations: The launcher should be rotated 90° from process connections.
- Configuration must include an entry for Stillwell I.D. See Section 2.6.6.2, Item 34- Stillwell I.D.

2.4.1.6 Open Channel Flow Measurement

For optimal accuracy, mount the transmitter a minimum of 30" above the flow element (this is dependent on type and size of the flow element). Consult factory for assistance on this dimension.

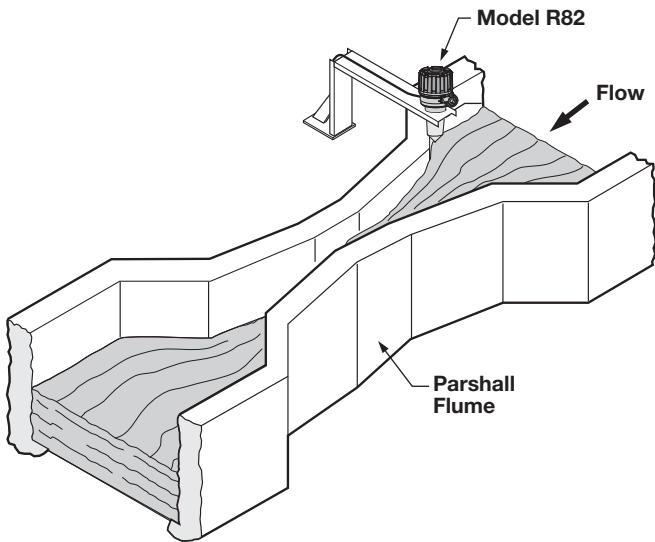

Figure 15
Open Channel Flow Mounting

Install the Model R82 on the inflow side of the flume throat or weir crest in the location defined by the manufacturer of the primary measuring device. The unit should also be aligned with the longitudinal axis of the flume or weir.

Open channel flow is performed by using the R82 to measure the level (Head) in a hydraulic structure. The hydraulic structure is the primary measuring element, of which the two most common types are weirs and flumes. Since the primary element has a defined shape and dimensions, the rate of flow through the flume or over the weir is related to the liquid level (Head) at a specified measurement location. The Model R82 is the secondary measuring device which measures the height (Head) of the liquid in the flume or weir. Open channel flow equations stored in the R82 firmware convert the measured Head into units of flow (volume/time).

NOTE:

Proper position of the Model R82 should be per the recommendation of the flume or weir manufacturer and meeting minimum height recommendations. Mounting at least 30" above the top of the element will yield best accuracy.

2.4.2 Installing the Transmitter

Install the Transmitter with its integral antenna by threading into the vessel. **DO NOT OVERTIGHTEN** as this may cause damage to the plastic threads.

- Do not place insulating material around any part of the radar transmitter including the antenna flange.
- Installation for NEMA 6P/IP 68: the R82 can be installed to allow for temporary submergence to 6.5 ft. (2m) for 24 hours:
 - use TFE paste to seal conduit entries or IP 68 cable glands
 - Do not overtighten plastic housing cover; O-ring develops water-tight seal without excessive tightening

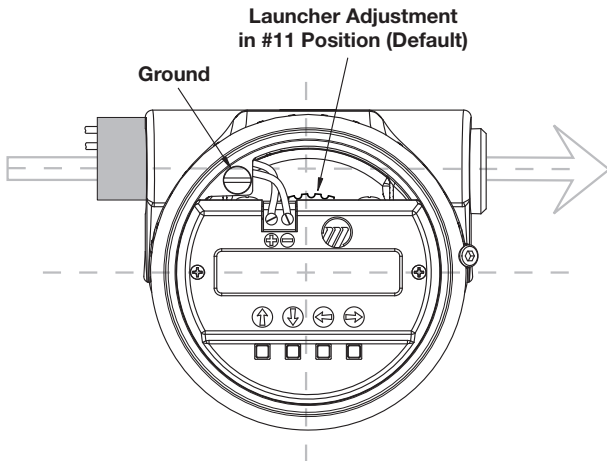

Figure 16
Launcher Adjustment in #11 Position (default)

2.4.2.1 Orientation

The R82 transmitter utilizes a linearly polarized, microwave beam that can be rotated to improve its performance. Proper orientation can minimize unwanted reflections, decrease sidewall reflections (multipath) and maximize direct reflections from the liquid surface.

The internal launcher mechanism can be turned to optimize performance. The launcher has index marks numbered 1–18 (representing 10–180 degrees). The polarization pattern is parallel to the transmitter display when the adjustment mechanism is in the #11 position (factory default). See Figures 16 and 17.

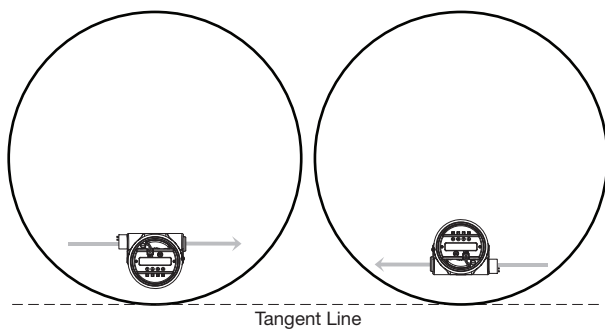

Figure 17
Polarization Pattern

2.4.2.2 Launcher Orientation—Level Application

Ideally, the transmitter should be mounted half the radius from the tank wall. In a typical vertical tank, the Launcher should be adjusted so the polarization pattern is parallel to a line tangent to the nearest tank wall. See Figure 17.

Rotate the internal Launcher adjustment to achieve the correct Polarization position. Remember each notch on the adjustment wheel is 10 degrees of rotation. See Figure 18.

For horizontal cylindrical vessels, aim beam down the long axis of the vessel. Do not optimize the Echo Strength at one level in the vessel.

A transmitter mounted within 10" (25 cm) of a tank wall may demand orientation adjustments to limit multipath and optimize performance. See Section 2.4.2.4, Poor Echo Strength.

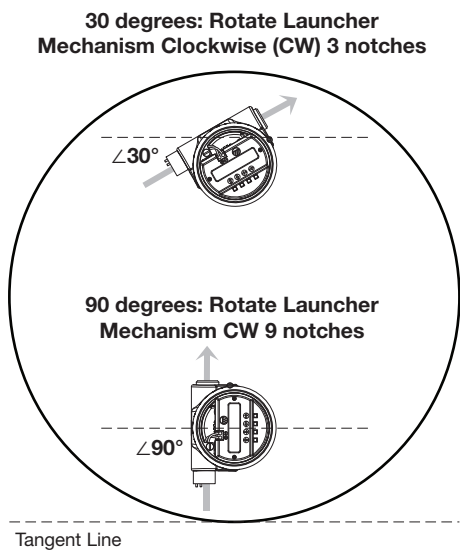

Figure 18
Examples of Launcher Orientation Adjustments

2.4.2.3 Launcher Orientation – Flow Application

Orient the R82 transmitter so the Polarization pattern is aimed directly down the throat of the flume or weir.

If conduit connections are oriented 90° to the flow, set the Launcher Adjustment to #2.

2.4.2.4 Poor Echo Strength

Poor Echo Strength has many potential causes. Following are two initial areas for investigation.

Launcher Orientation: Initial launcher orientation is always parallel to tangent of the tank circumference (see Sections 2.4.2.1 & 2.4.2.2). In tall vessels and when antenna is mounted close to the tank wall, improvement in Echo Strength may be attained by rotating the launcher to 90 degrees.

Signal Loss: If the Level signal is lost repeatedly at a specific point in the vessel, it is usually a symptom that multipath (side-wall reflections) are causing cancellation by returning to the transmitter exactly 180° out of phase with the Level signal. Utilize the following procedure:

- Go to transmitter screen #5 which shows both Level and Echo Strength.
- Bring the Level up (or down) to the exact point where the signal is repeatedly lost. Monitor the Echo Strength this point is being approached. The Echo Strength will degrade to a low point before it begins to increase.
- At the poorest Echo Strength slowly rotate the launcher 1–2 notches. Allow the unit to stabilize for approximately one minute. Repeat this process until the Echo Strength is optimized.

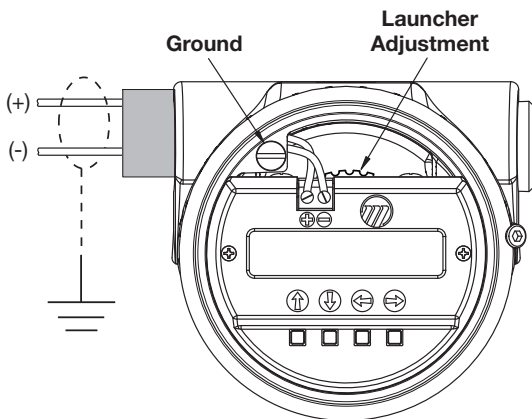

Figure 19
Internal Launcher Adjustment

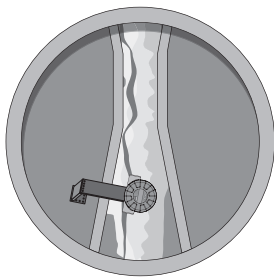

Figure 20
Mounting Over Flume

2.5 Wiring

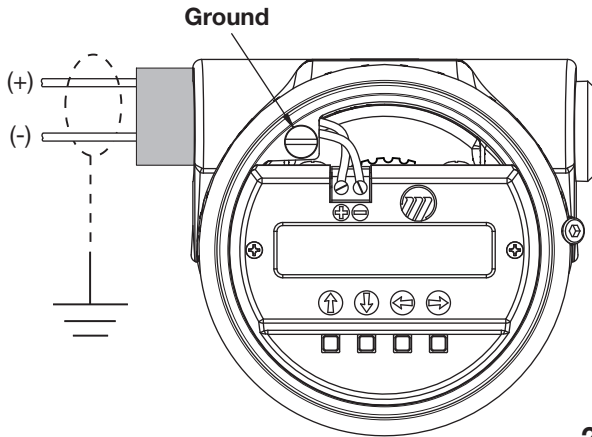

Figure 21
Wiring the Transmitter

Caution: The R82 Radar transmitter operates at voltages of 16–36 VDC (GP) and 16–28.6 VDC (IS). Higher voltage will damage the transmitter.

NOTES:

- If sufficient supply voltage is suspect, use the R82 Low Voltage check (Section 2.6.6.1, #33: Test 4-20 Loop).
- For ATEX installation guidelines refer to bulletin BE 58-610.

Wiring between the power supply and the Radar transmitter should be made using 18–22 AWG shielded twisted pair instrument cable. Within the transmitter enclosure, connections are made to the terminal strip and the ground connections. Trim excess wiring to minimize clutter, noise issues and allow access to Launcher adjustment. See Figure 21. The directions for wiring the Radar transmitter depend on the application:

- General Purpose or Non-incendive (CI I, Div. 2)
- Intrinsically Safe

2.5.1 General Purpose or Non-incendive (CI I, Div. 2)

A general purpose installation does not have flammable media present. Areas rated non-incendive (CI I, Div. 2) have flammable media present only under abnormal conditions. No special electrical connections are required. If flammable media is contained in the vessel, the transmitter must be installed per CI I, Div. 1 standards of area classification.

To install General Purpose or Non-incendive wiring:

1. Remove the cover to the wiring compartment of the transmitter. Install the conduit plug in the unused opening.
2. Install a conduit fitting and pull the supply wires.
3. Connect shield to an earth ground at power supply and leave floating at the transmitter.
4. Connect an earth ground wire to the nearest green ground screw per local electrical code (not shown in illustration).
5. Connect the positive supply wire to the (+) terminal and the negative supply wire to the (-) terminal.
6. Seal conduit to prevent ingress of moisture.
7. Replace cover of the transmitter.

2.5.2 Intrinsically Safe

An intrinsically safe (IS) installation potentially has flammable media present. An approved IS barrier must be installed in the non-hazardous (safe) area.

To install Intrinsically Safe wiring:

1. Make sure the IS barrier is properly installed in the safe area (refer to local plant or facility procedures). Complete the wiring from the barrier to the Radar transmitter.
2. Remove the cover of the transmitter. Install the conduit plug in the unused opening.
3. Install a conduit fitting and pull the supply wires.
4. Connect shield to an earth ground at power supply and leave floating at the transmitter.

5. Connect an earth ground wire to the nearest green ground screw (not shown in illustration).
6. Connect the positive supply wire to the (+) terminal and the negative supply wire to the (-) terminal.
7. Replace the cover of the transmitter.

2.6 Configuring the Transmitter

The Radar transmitter comes factory-calibrated and can be configured in minutes for specific applications.

Before configuring the transmitter, collect the operating parameters information. Then, power-up the transmitter on the bench and follow through the step-by-step procedures for the menu-driven transmitter display. Information on configuring the transmitter using a HART communicator is given in Configuration Using HART (Section 2.7).

2.6.1 Operating Parameters

Some key information is needed to configure the Radar transmitter. If necessary, complete the configuration information table in Section 1.1.2.

2.6.2 Setting Up for Shop Configuration

The Radar transmitter can be configured at a test bench by connecting a 24 VDC power supply directly to the transmitter terminals. The connections are illustrated in the accompanying diagrams. An optional digital multimeter is shown if current measurements are desired.

When using a HART communicator for configuration, a minimum 250 Ω line load resistance is required. See the HART communicator manual for more information.

2.6.3 Transmitter Display and Keypad

The R82 transmitter has a local user interface consisting of a 2-line \times 16-character liquid-crystal display (LCD) and 4-push-button keypad. All transmitter measurement data and configuration information is shown in the LCD.

The transmitter default display is the measurement screen. It cycles every 2 seconds to display *STATUS*, *LEVEL*, *ECHO STRENGTH*, *%OUTPUT*, *LOOP CURRENT* and *LOCAL TAG* information. The transmitter defaults to this display after 5 minutes if no keystrokes are sensed. You can also access each of these screens individually. The display will not return to the default screen if left in one of these screens. For example, the device can be left to display only LEVEL indefinitely if left in this screen.

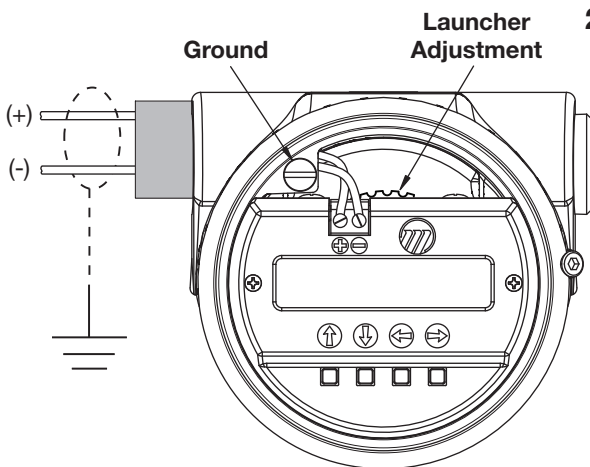





Figure 22
Display and Keypad

2.6.4 Menu Traversal and Data Entry

The four push buttons offer various forms of functionality for navigation and data entry (i.e., Navigation, Data Selection, etc.).

2.6.4.1 Navigating Menu

Push button		Keystroke Action
	Up	Moves to the previous item in the menu branch
	Down	Moves to the next item in the menu branch
	Back	Moves back one level to the previous higher branch item
	Enter	Enters into the lower level branch or switches to the entry mode

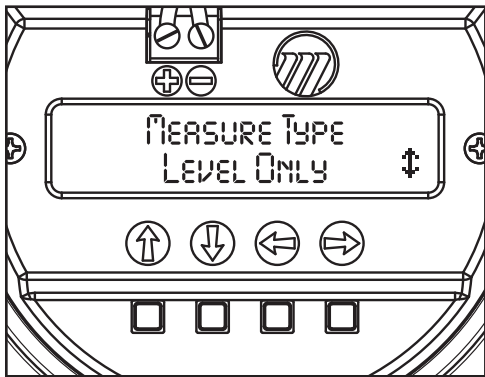

Figure 23

2.6.4.2 Data Selection

Use this method for selecting configuration data from a specific list. An arrow will appear when in the Data Selection mode. See Figure 23.

Use the following procedure:

- UP and DOWN arrows to navigate the main menu
- ENTER arrow to allow modification of selection
- UP and DOWN arrows to choose new selection
- ENTER arrow to confirm selection
- Use BACK (Escape) key at any time to abort the procedure and escape to previous branch item.

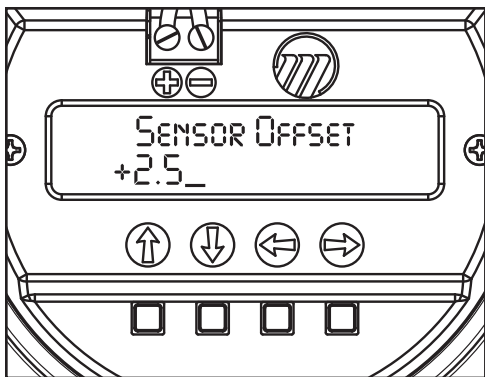





Figure 24

NOTES: All numeric values are left-justified, and new values are entered from left to right. A decimal point can be entered after the first digit is entered, such that .9 is entered as 0.9.

Some configuration items can have a negative value. In this case, the leftmost position is reversed for the sign (either “-” for a negative value, or “+” for a positive value).

2.6.4.3 Entering Numeric Data Using Digit Entry

Use this method to input numeric data, e.g., Sensor Offset.

Push button		Keystroke Action
	Up	Moves up to the next highest digit (0,1,2,3,...,9). If held down the digits scroll until the push button is released.
	Down	Moves down to the next lowest digit (9,8,7,6,...,0). If held down the digits scroll until the push button is released.
	Back	Moves the cursor to the left and deletes a digit. If the cursor is already at the leftmost position, then the screen is exited without changing the previously saved value.
	Enter	Moves the cursor to the right. If the cursor is located at a blank character position, the new value is saved.

2.6.4.4 Entering Numeric Data Using Increment/Decrement

Use this method to input the following data: Damping, Echo Loss Delay, Trim Level, Trim 4 mA, Trim 20 mA, Test 4-20 Loop and HART Poll Addr.

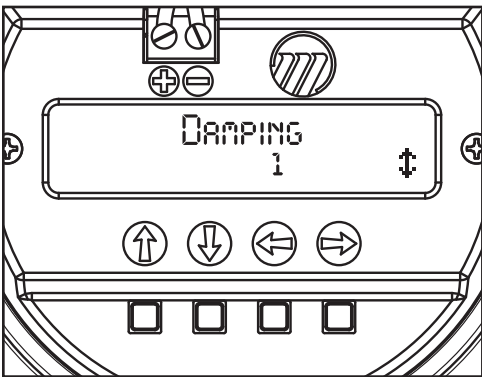

Figure 25

Push button		Keystroke Action
⬆	Up	Increments the displayed value. If held down the digits scroll until the push button is released. Depending on which screen is being revised, the increment amount may increase by a factor of 10 after the value has been incremented 10 times.
⬇	Down	Decrements the displayed value. If held down the digits scroll until the push button is released. Depending on which screen is being revised, the decrement amount may increase by a factor of 10 after the value has been decremented 10 times.
⬅	Back	Returns to the previous menu without changing the original value, which is immediately redisplayed.
➡	Enter	Accepts the displayed value and returns to the previous menu.

2.6.4.5 Entering Character Data

This method is used for entering alphanumeric characters, e.g., Input Local Tag.

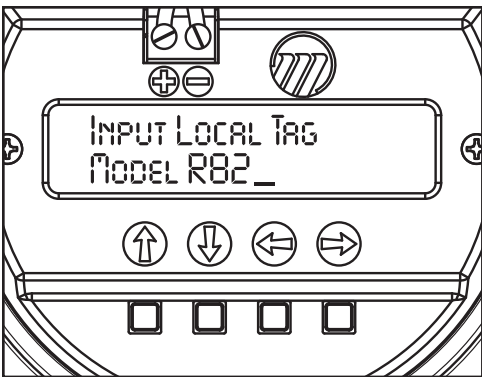

Figure 26

Push button		Keystroke Action
⬆	Up	Moves to the previous character (Z,Y,X,W). If held down the characters scroll until the push button is released.
⬇	Down	Moves to the next item character (A,B,C,D). If held down the characters scroll until the push button is released.
⬅	Back	Moves the cursor back to the left. If the cursor is already at the leftmost position, then the screen is exited without changing the original tag characters.
➡	Enter	Moves the cursor forward to the right. If the cursor is at the rightmost position, then the new tag is saved.

2.6.5 Password Protection (Default = 0)

The Radar transmitter is password protected to restrict access to certain portions of the menu structure that affect the operation of the system. The password can be changed to any numerical value up to 255. The password is required whenever configuration values are changed.

The default password installed in the transmitter at the factory is 0 (password disabled). The last step in the configuration menu provides the option to enter a new password. If 0 is entered as a password, the transmitter is no longer password protected and any value in the menu can be altered (except diagnostic values) without entering a confirming password.

NOTE: If the password is not known, the menu item New Password (Section 2.6.6.1 Level Measurement Only, item #35; Section 2.6.6.2 Volume and Level, item #39; Section 2.6.6.3 Flow and Level, item #41) displays an encrypted value representing the present password. Call the factory with this encrypted value to determine the actual password.

2.6.6 Menu: Step-By-Step Procedure

The following tables provide a complete explanation of the software menus displayed by the Radar transmitter. Use these tables as a step-by-step guide to configure the transmitter.

The first column presents the menus shown on the transmitter display. The displays are in the order they would appear if the arrow keys were used to scroll through the menu. The numbers are not shown on the display. They are provided as a reference only.

The second column provides the actions to take when configuring the transmitter. Additional information or an explanation of an action is given in the third column.

Figure 27 provides reference to the configuration procedure.

Use of the included PACTware™ PC program is highly recommended and invaluable for troubleshooting and advanced calibration. A HART RS232 or USB modem (purchased separately) is required. See MAGNETROL PACTware™ bulletin 59-101.

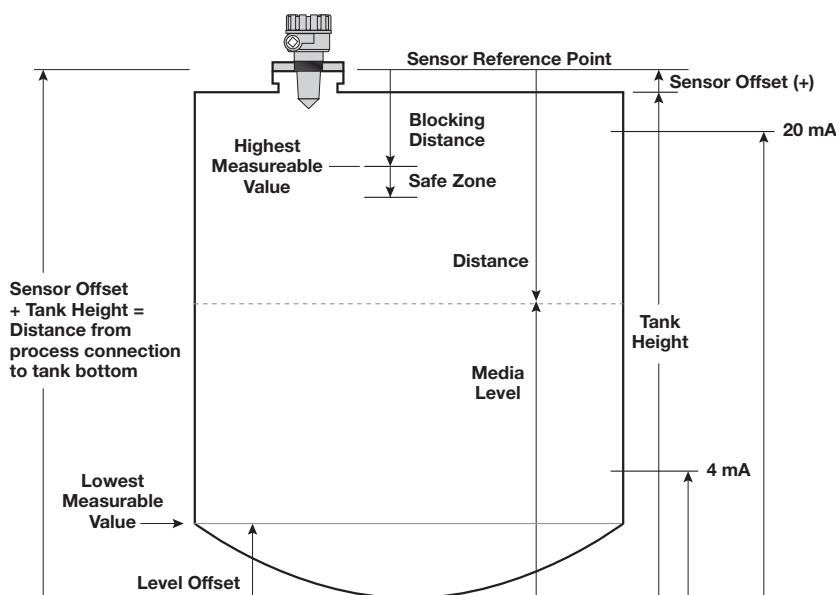

Figure 27

2.6.6.1 Radar Transmitter User Menu—Level Measurement Only

Note: Press UP arrow 5 times to reach screen where menu language can be chosen.

	Display	Action	Comment
1	*Status* *Level* *Volume* *Distance* *Echo Str xx* *%Output* *Loop Current* *Local Tag*	Transmitter Display	Transmitter default display: Status, Level, Distance, Echo Strength, % Output, Loop Current and Local Tag values advance every 2 seconds. All screens (except 2-8) default to this screen after 5 minutes of no keystrokes or if a Fault or Warning message is displayed. Default display will also show the highest priority Fault or Warning. If more than one Fault or Warning exists they will be displayed in the History screen (Item #2, Section 2.6.6.4 <i>Radar Transmitter Factory Menu</i> on Page 40) in chronological order. To Add/Remove what information is shown in default display: <ul style="list-style-type: none"> • Go to specific parameter in question (screens 2-8) • Press Enter • Choose On or Off • Press Enter to confirm
2	Level xxx.x units	Transmitter Display	Transmitter displays Level measurement in chosen unit of measure.
3	Distance xxx.x units	Transmitter Display	Transmitter displays Distance measurement in chosen unit of measure; measurement includes Sensor Offset value. This value may not represent reciprocal of Level if the liquid level is within the Blocking Distance or Level Offset where the Level value is clamped.
4	Echo Strength xx xxx.x units	Transmitter Display	Transmitter display showing Level and Echo Strength of signal reflection. Good values are 20-99.
5	% Output xx.x%	Transmitter Display	Transmitter displays % Output measurement derived from 20 mA span.
6	Loop Current xx.xx mA	Transmitter Display	Transmitter displays Loop Current value (mA).
7	Local Tag xxxxxxxxxxxx	Transmitter Display	Transmitter displays Local Tag information.
8	Measure Type (select)	Select Type of Measurement	Select Level Only or Flow & Level, Volume & Level, Flow, Flow Units, Volume, Volume Units, Loop Control, and Strapping Table screens appear when necessary. Note that the Flow or Volume screens are selected for rotation when Measure Type is set to Flow & Level or Volume & Level and is deselected when Measure Type is set to Level Only. See Section 2.6.6.2 for the complete Volume and Level menu or 2.6.6.3 for the complete Flow and Level menu.
9	Level Units (select)	Select Units of measure	Select cm (xxxx), meters (xx.xx), inches (xxx.x), or feet (xx.xx). Allowable decimal position is controlled; four characters is maximum reading. Decimal position is controlled by Units and Tank Height.
10	Sensor Offset xx.x units	Enter the Sensor Offset value	Sensor Offset is the distance (+ or -) from the Sensor reference point (bottom of NPT thread or flange face, top of BSP thread) to the top of the tank.
11	Tank Top (select)	Enter the shape/type of tank top	Select the metallic tank top structure Flat, Horizontal Cylinder, Dome, Irregular, or Other (non-metallic).
12	Tank Height xxx.xx units	Enter the Tank Height	Tank Height is distance from the bottom to the top of the tank.

2.6.6.1 Radar Transmitter User Menu—Level Measurement Only (cont.)

Note: Press UP arrow 5 times to reach screen where menu language can be chosen.

	Display	Action	Comment
13	Blocking Distance (xxx.x)	Enter the Blocking Distance	Blocking Distance defines an area near the antenna where reflections can not be measured effectively due to antenna ringing. It is measured from the Sensor Reference point. Default of 15" (380 mm) minimum distance from the process connection to the maximum level. Extend this value when necessary to block reflections from objects close to the antenna. Output will be held at value corresponding to Blocking Distance. Do not allow liquid into the Blocking Distance as false readings can result.
14	Level Offset (xxx.x units)	Enter the Level Offset	Level Offset defines an area at the bottom of the vessel where reflections can not be measured effectively due to angled bottoms, heating coils, reflections from flat metal tank bottoms in low dielectric applications, etc. It is the distance from the bottom of the tank to the lowest valid level reading. Level reading will never be lower than Level Offset value.
15	Dielectric (select)	Enter the Dielectric range value	1.7-3.0; 3.0-10.0; 10.0-100.0
16	Turbulence (select)	Select amount of Turbulence of the liquid	None, Light, Medium, Heavy. Increase selection if Echo is often lost or Echo Strength is <20.
17	Foam (select)	Select amount of Foam	None, Light, Medium, Heavy. Increase selection if Echo is often lost or Echo Strength is <20.
18	Rate of Change (select)	Select Rate of Change of the liquid	Select the maximum rate of change of the level surface, rising or falling, in inches (cm)/minute; <5 (13), 5-20 (13-50), 20-60 (50-150), >60 (150)
19	Echo Profile	Press Enter to - Review all Echoes - Run a new Echo Rejection Profile	<p>1.) Echo List Mode- Choose to review echoes in Distance or Level</p> <p>2.) Review all echoes using UP/DOWN arrows; listed in descending Level value</p> <p>3.) To run a new Echo Rejection Profile</p> <p>a.) Choose the echo that corresponds to the actual liquid level</p> <p>b.) Press ENTER and confirm a new Echo Rejection profile should be run. If necessary, Press ESCAPE to exit at any time.</p> <p>NOTES:</p> <ul style="list-style-type: none"> - ECHO REJECTION should run with vessel at or near empty when all targets are exposed - Re-run this routine if initial calibration is done with significant liquid in vessel - The Echo Rejection profile will be disabled and this routine must be re-run if the following parameters are modified: SENSOR OFFSET, TANK HEIGHT, BLOCKING DISTANCE, DIELECTRIC, TURBULENCE, FOAM - The EchoRej Invalid message will be displayed if this algorithm is DISABLED due to a parameter change. <p style="text-align: right;"><i>continued on next page</i></p>

2.6.6.1 Radar Transmitter User Menu—Level Measurement Only (cont.)

Note: Press UP arrow 5 times to reach screen where menu language can be chosen.

	Display	Action	Comment
19	Echo Profile (cont.)	- Review an existing Echo Rejection Profile	<i>continued from previous page</i> 4.) Enter Level- use this entry to manually enter the correct level value Error messages: “Echo too Close” indicates the liquid is too close to the antenna. Liquid should not be closer than 30" (750 mm). “Echo too Strong” indicates an echo being rejected is too strong. a.) Ensure it is not the actual liquid level b.) Rotate the Launcher to minimize the echo 5.) Saved Echo Rejection Profile- a.) Enable or Disable an existing profile b.) Review Echoes from an existing profile c.) Review Level value where existing profile was run
20	4 mA Set Point (xxx.x units)	Enter the value for the 4 mA point	During normal operation, mA value will clamp at boundary defined by the Level Offset value (refer to #14).
21	20 mA Set Point (xxx.x units)	Enter the value for the 20 mA point	During normal operation, mA value will clamp at boundary defined by the Blocking Distance value (refer to #13).
22	Damping (xx sec)	Enter the Damping factor	A damping factor (0-45) may be added to smooth a noisy display and/or output due to turbulence.
23	System Fault (select)	Select the System Fault value	Select 3.6 mA, 22 mA or HOLD (last value).
24	Echo Loss Fault (select)	Select the Echo Loss Fault value	Select 3.6 mA, 22 mA or HOLD (last value).
25	Echo Loss Delay (xxx sec)	Enter the value for the Echo Loss Delay	Select a value 0-1000; 30 is default.
26	Safe Zone Fault (select)	Select the Safe Zone Fault	Safe Zone is a user-defined area just below the Blocking Distance. Set this Fault if it necessary to ensure safe, reliable high-level readings in critical applications. Choices are None, 3.6 mA, 22 mA, Latch 3.6 or Latch 22. If Latch 3.6 or Latch 22 is chosen, the loop current will remain in alarm until it is cleared by customer in SZ Alarm below (refer to #28)
27	Safe Zone Height (xx.x units)	Enter a Safe Zone Distance	Enter a distance value that develops a zone just below the Blocking Distance. At this point the unit will report a Safety Zone Fault (refer to #26) if the level rises into this area.
28	Safe Zone Alarm (Reset)	Clear Safe Zone Alarm	Clear a latched Safe Zone alarm.
29	Trim Level (xxx.x units)	Enter a Trim Level value	Trim Level is an offset value to be used to force the transmitter to output the proper Level. This should only be used after Tank Height and Sensor Offset have been confirmed as correct. -24 to +24 inches (-61 to +61 cm).
30	Stillwell I.D. (xx.x units)	Enter Pipe I.D.	For measuring in a stillwell. Enter a value for inside diameter of the pipe (presently only 2" (50mm) is acceptable). Value must be left as 0 if no standpipe/stillwell is present.
31	Trim 4 mA	Fine tune the 4mA point	Attach a mA meter to the output. If the output does not equal 4.00 mA, adjust the value on the display until meter reads 4.00 mA. This is not for setting the 4mA point (refer to #20).

2.6.6.1 Radar Transmitter User Menu—Level Measurement Only (cont.)

Note: Press UP arrow 5 times to reach screen where menu language can be chosen.

	Display	Action	Comment
32	Trim 20 mA	Fine tune the 20mA point	Attach a mA meter to the output. If the output does not equal 20.00 mA, adjust the value on the display until meter reads 20.00 mA. This is not for setting the 20mA point (refer to #21).
33	Test 4–20 Loop (xx.xx mA)	Enter a mA Output value	This screen serves two functions: 1.) Calibrate Loop: Enter mA output value to send a constant current. Present current will be returned upon exiting screen 2.) Check for sufficient loop voltage @20mA: a.) Drive current value to 4.00mA b.) Drive current value to >10mA c.) Press ENT; top line of display will show - (???) if done incorrectly - (OK) if sufficient VDC is calculated - (Low) if insufficient VDC is calculated d.) Bottom line of display will show calculated loop voltage at 20mA
34	Hart Poll Addr (xx)	Select HART Poll Address number	Select HART Poll Address number. Select a HART Poll Address (0-15). Enter 0 for a single transmitter installation; enter 1-15 for multi-drop HART network.
35	New Password (enter)	Enter new Password	Enter the desired Password value between 0 and 255; 0 = No Password. During normal operation an encrypted password is shown. Consult factory to decrypt this value, if necessary.
36	Configuration Reset	Enter to Reset Parameters	Reset configuration parameters to factory default values.
37	Language (select)	Select Language	Select Language that will be displayed on the transmitter screen. English, Espanol, Deutsch and Francais.
38	Input Local Tag (enter)	Enter Local Tag	Local Tag can be a maximum of 12 characters.
39	Magnetrol S/N	Transmitter Display	Shows MAGNETROL Serial Number for reference.
40	Model R82 version	Transmitter Display	Base Model Number with Communication type (HT = HART) Firmware Version and Date.
41	Factory Params	Enter to display Factory Parameters	Enter to display Factory Parameters. This section displays twenty-nine screens. The History screens are of particular importance to the user as they show a listing of chronological, diagnostic events, most recent first.

2.6.6.2 Radar Transmitter User Menu—Volume and Level

Note: Press UP arrow 5 times to reach screen where menu language can be chosen.

	Display	Action	Comment
1	*Status* *Level* *Volume* *Distance* *Echo Str xx* *%Output* *Loop Current* *Local Tag*	Transmitter Display	Transmitter default display: Status, Level, Distance, Echo Strength, % Output, Loop Current and Local Tag values advance every 2 seconds. All screens (except 2-8) default to this screen after 5 minutes of no keystrokes or if a Fault or Warning message is displayed. Default display will also show the highest priority Fault or Warning. If more than one Fault or Warning exists they will be displayed in the History screen (Item #2, Section 2.6.6.4 <i>Radar Transmitter Factory Menu</i> on Page 40) in chronological order. To Add/Remove what information is shown in default display: <ul style="list-style-type: none"> • Go to specific parameter in question (screens 2-8) • Press Enter • Choose On or Off • Press Enter to confirm
2	Level xxx.x units	Transmitter Display	Transmitter displays Level measurement in chosen unit of measure.
3	Volume xxx.x units	Transmitter Display	Transmitter displays Volume measurement in chosen unit of measure.
4	Distance xxx.x units	Transmitter Display	Transmitter displays Distance measurement in chosen unit of measure; measurement includes Sensor Offset value. This value may not represent reciprocal of Level if the liquid level is within the Blocking Distance or Level Offset where the Level value is clamped.
5	Echo Strength xx xxx.x units	Transmitter Display	Transmitter display showing Level and Echo Strength of signal reflection. Good values are 20-99.
6	% Output xx.x%	Transmitter Display	Transmitter displays % Output measurement derived from 20 mA span.
7	Loop Current xx.xx mA	Transmitter Display	Transmitter displays Loop Current value (mA).
8	Local Tag xxxxxxxxxxxx	Transmitter Display	Transmitter displays Local Tag information.
9	Measure Type (select)	Select Type of Measurement	Select Level Only or Flow & Level, Volume & Level, Flow, Flow Units, Volume, Volume Units, Loop Control, and Strapping Table screens appear when necessary. Note that the Flow or Volume screens are selected for rotation when Measure Type is set to Flow & Level or Volume & Level and is deselected when Measure Type is set to Level Only. See Section 2.6.6.1 for the complete Level menu or 2.6.6.3 for the complete Flow and Level menu.
10	Level Units (select)	Select Units of measure	Select cm (xxxx), meters (xx.xx), inches (xxx.x), or feet (xx.xx). Allowable decimal position is controlled; four characters is maximum reading. Decimal position is controlled by Units and Tank Height.
11	Sensor Offset xx.x units	Enter the Sensor Offset value	Sensor Offset is the distance (+ or -) from the Sensor reference point (bottom of NPT thread or flange face, top of BSP thread) to the top of the tank.
12	Tank Top (select)	Enter the shape/type of tank top	Select the metallic tank top structure Flat, Horizontal Cylinder, Dome, Irregular, or Other (non-metallic).
13	Tank Height xxx.xx units	Enter the Tank Height	Tank Height is distance from the bottom to the top of the tank.

2.6.6.2 Radar Transmitter User Menu—Volume and Level (cont.)

Note: Press UP arrow 5 times to reach screen where menu language can be chosen.

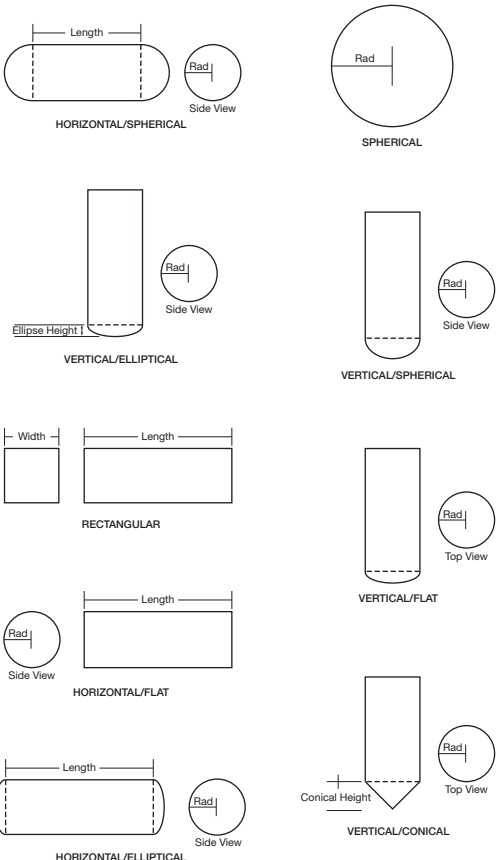
	Display	Action	Comment
14	Blocking Distance (xxx.x)	Enter the Blocking Distance	Blocking Distance defines an area near the antenna where reflections can not be measured effectively due to antenna ringing. It is measured from the Sensor Reference point. Default of 15" (380 mm) minimum distance from the process connection to the maximum level. Extend this value when necessary to block reflections from objects close to the antenna. Output will be held at value corresponding to Blocking Distance. Do not allow liquid into the Blocking Distance as false readings can result.
15	Level Offset (xxx.x units)	Enter the Level Offset	Level Offset defines an area at the bottom of the vessel where reflections can not be measured effectively due to angled bottoms, heating coils, reflections from flat metal tank bottoms in low dielectric applications, etc. It is the distance from the bottom of the tank to the lowest valid level reading. Level reading will never be lower than Level Offset value.
16	Volume Setup (continued on next page)	Enter the Volume Information	<p>The following table provides an explanation of each of the System Configuration parameters for volume applications that use one of the nine Vessel Types. See below for reference information on all nine Vessel Types.</p>  <p>The diagrams illustrate the following vessel types:</p> <ul style="list-style-type: none"> HORIZONTAL/SPHERICAL: Side view shows length and radius; top view is a circle. SPHERICAL: Top view is a circle with radius. VERTICAL/ELLIPTICAL: Side view shows ellipse height and radius; top view is a circle. VERTICAL/SPHERICAL: Side view shows radius; top view is a circle. RECTANGULAR: Top view shows width and length. VERTICAL/FLAT: Side view shows radius; top view is a rectangle. HORIZONTAL/FLAT: Side view shows radius; top view shows length. HORIZONTAL/ELLIPTICAL: Side view shows length and radius; top view is a circle. VERTICAL/CONICAL: Side view shows conical height and radius; top view is a circle.

2.6.6.2 Radar Transmitter User Menu—Volume and Level (cont.)

Note: Press UP arrow 5 times to reach screen where menu language can be chosen.

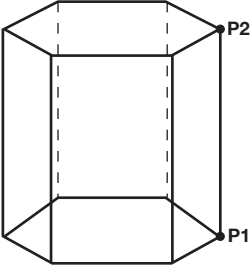
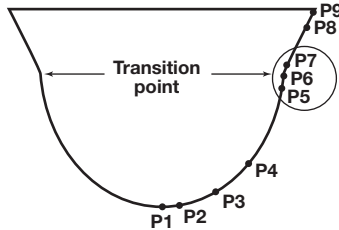
	Display	Action	Comment
16	Volume Setup (continued from previous page)	Volume Units	A selection of Gallons (factory default Volume Unit), Milliteters , Liters , Cubic Feet , or Cubic Inches , is provided. Should some other units of volume be desired, the Custom Unit feature can be used in the Advanced Configuration Menu.
		Vessel Type	Select either Vertical/Flat (factory default Vessel Type), Vertical/Ellip. , Vertical/Sphere , Vertical/Conical , Custom Table , Rectangular , Horizontal/Flat , Horiz./Ellip. , Horiz./Sphere , Spherical or Custom Table (See Item #17).
		Vessel Dims	Depending on which <i>Vessel Type</i> was selected, the next few screens will allow entry of the vessel dimensions. Radius is used for all <i>Vessel Types</i> with the exception of <i>Rectangular</i> vessels. Ellipse Height is only used for <i>Vertical/Ellip</i> vessels. Conical Height is only used for <i>Vertical/Conical</i> vessels. Width is only used for <i>Rectangular</i> vessels. Length is only used for <i>Rectangular</i> and the three <i>Horizontal</i> vessels. Ellipse End is only used for <i>Horiz/Ellip</i> vessels.
17	Volume Custom Table	Enter information for Custom Table	The <i>Custom Table</i> points can be a Linear (straight line between adjacent points) or Spline (can be a curved line between points) relationship.
		Cust Table Type	The <i>Custom Table</i> points can be a Linear (straight line between adjacent points) Spline (can be a curved line between points) relationship.
		Cust Table Values	<p>A maximum of 20 points can be used in building the <i>Custom Table</i>. Each pair of values will have a level (height) in the units chosen in the <i>Level Units</i> screen, and the associated volume for that level point. The values must be monotonic, i.e., each pair of values must be greater than the previous level/volume pair. The last pair of values should have the highest level value (usually the <i>Range</i> value) and the volume associated with that level in the vessel.</p> <div style="display: flex; justify-content: space-around; align-items: flex-end;"> <div style="text-align: center;">  <p>LINEAR</p> </div> <div style="text-align: center;">  <p>SPLINE</p> <p>Use where walls are not perpendicular to base. Concentrate at least two points at beginning (P1) and end (P9); and three points at either side of transition points.</p> </div> </div>

2.6.6.2 Radar Transmitter User Menu—Volume and Level (cont.)

Note: Press UP arrow 5 times to reach screen where menu language can be chosen.

	Display	Action	Comment
18	Dielectric (select)	Enter the Dielectric range value	1.7-3.0; 3.0-10.0; 10.0-100.0
19	Turbulence (select)	Select amount of Turbulence of the liquid	None, Light, Medium, Heavy. Increase selection if Echo is often lost or Echo Strength is <20.
20	Foam (select)	Select amount of Foam	None, Light, Medium, Heavy. Increase selection if Echo is often lost or Echo Strength is <20.
21	Rate of Change (select)	Select Rate of Change of the liquid	Select the maximum rate of change of the level surface, rising or falling, in inches (cm)/minute; <5 (13), 5-20 (13-50), 20-60 (50-150), >60 (150)
22	Echo Profile	<p>Press Enter to</p> <ul style="list-style-type: none"> - Review all Echoes - Run a new Echo Rejection Profile - Review an existing Echo Rejection Profile 	<p>1.) Echo List Mode- Choose to review echoes in Distance or Level</p> <p>2.) Review all echoes using UP/DOWN arrows; listed in descending Level value</p> <p>3.) To run a new Echo Rejection Profile</p> <ul style="list-style-type: none"> a.) Choose the echo that corresponds to the actual liquid level b.) Press ENTER and confirm a new Echo Rejection profile should be run. If necessary, Press ESCAPE to exit at any time. <p>NOTES:</p> <ul style="list-style-type: none"> - ECHO REJECTION should run with vessel at or near empty when all targets are exposed - Re-run this routine if initial calibration is done with significant liquid in vessel - The Echo Rejection profile will be disabled and this routine must be re-run if the following parameters are modified: SENSOR OFFSET, TANK HEIGHT, BLOCKING DISTANCE, DIELECTRIC, TURBULENCE, FOAM - The EchoRej Invalid message will be displayed if this algorithm is DISABLED due to a parameter change. <p>4.) Enter Level- use this entry to manually enter the correct level value</p> <p>Error messages:</p> <p>“Echo too Close” indicates the liquid is too close to the antenna. Liquid should not be closer than 30" (750 mm).</p> <p>“Echo too Strong” indicates an echo being rejected is too strong.</p> <ul style="list-style-type: none"> a.) Ensure it is not the actual liquid level b.) Rotate the Launcher to minimize the echo <p>5.) Saved Echo Rejection Profile-</p> <ul style="list-style-type: none"> a.) Enable or Disable an existing profile b.) Review Echoes from an existing profile c.) Review Level value where existing profile was run
23	Loop Control (select)	Select mode for Loop Control	Select Level or Volume.
24	4 mA Set Point (xxx.x units)	Enter the value for the 4 mA point	During normal operation, mA value will clamp at boundary defined by the Level Offset value (refer to #15).
25	20 mA Set Point (xxx.x units)	Enter the value for the 20 mA point	During normal operation, mA value will clamp at boundary defined by the Blocking Distance value (refer to #14).

2.6.6.2 Radar Transmitter User Menu—Volume and Level (cont.)

Note: Press UP arrow 5 times to reach screen where menu language can be chosen.

	Display	Action	Comment
26	Damping (xx sec)	Enter the Damping factor	A damping factor (0-45) may be added to smooth a noisy display and/or output due to turbulence.
27	System Fault (select)	Select the System Fault value	Select 3.6 mA, 22 mA or HOLD (last value).
28	Echo Loss Fault (select)	Select the Echo Loss Fault value	Select 3.6 mA, 22 mA or HOLD (last value).
29	Echo Loss Delay (xxx sec)	Enter the value for the Echo Loss Delay	Select a value 0-1000; 30 is default
30	Safe Zone Fault (select)	Select the Safe Zone Fault	Safe Zone is a user-defined area just below the Blocking Distance. Set this Fault if it necessary to ensure safe, reliable high-level readings in critical applications. Choices are None, 3.6 mA, 22 mA, Latch 3.6 or Latch 22. If Latch 3.6 or Latch 22 is chosen, the loop current will remain in alarm until it is cleared by customer in SZ Latch below (refer to #32).
31	Safe Zone Height (xx.x units)	Enter a Safe Zone Distance	Enter a distance value that develops a zone just below the Blocking Distance. At this point the unit will report a Safety Zone Fault (refer to #30) if the level rises into this area.
32	Safe Zone Alarm (Reset)	Clear Safe Zone Alarm	Clear a latched Safe Zone alarm.
33	Trim Level (xxx.x units)	Enter a Trim Level value	Trim Level is an offset value to be used to force the transmitter to output the proper Level. This should only be used after Tank Height and Sensor Offset have been confirmed as correct. -24 to +24 inches (-61 to +61 cm).
34	Stillwell I.D. (xx.x units)	Enter Pipe I.D.	For measuring in a stillwell. Enter a value for inside diameter of the pipe (presently only 2" (50mm) is acceptable). Range of values 0, 3-20 inches (0, 40-500 mm). Value must be left as 0 if no standpipe/stillwell is present.
35	Trim 4 mA	Fine tune the 4mA point	Attach a mA meter to the output. If the output does not equal 4.00 mA, adjust the value on the display until meter reads 4.00 mA. This is not for setting the 4mA point (refer to #24).
36	Trim 20 mA	Fine tune the 20mA point	Attach a mA meter to the output. If the output does not equal 20.00 mA, adjust the value on the display until meter reads 20.00 mA. This is not for setting the 20mA point (refer to #25).
37	Test 4–20 Loop (xx.xx mA)	Enter a mA Output value	This screen serves two functions: 1.) Calibrate Loop: Enter mA output value to send a constant current. Present current will be returned upon exiting screen 2.) Check for sufficient loop voltage @20mA: a.) Drive current value to 4.00mA b.) Drive current value to >10mA c.) Press ENT; top line of display will show - (????) if done incorrectly - (OK) if sufficient VDC is calculated - (Low) if insufficient VDC is calculated d.) Bottom line of display will show calculated loop voltage at 20mA
38	Hart Poll Addr (xx)	Select HART Poll Address number	Select HART Poll Address number. Select a HART Poll Address (0-15). Enter 0 for a single transmitter installation; enter 1-15 for multi-drop HART network.
39	New Password (enter)	Enter new Password	Enter the desired Password value between 0 and 255; 0 = No Password. During normal operation an encrypted password is shown. Consult factory to decrypt this value, if necessary.
40	Configuration Reset	Enter to Reset Parameters	Reset configuration parameters to factory default values.

2.6.6.2 Radar Transmitter User Menu—Volume and Level (cont.)

Note: Press UP arrow 5 times to reach screen where menu language can be chosen.

	Display	Action	Comment
41	Language (select)	Select Language	Select Language that will be displayed on the transmitter screen. English, Espanol, Deutsch and Francais.
42	Input Local Tag (enter)	Enter Local Tag	Local Tag can be a maximum of 12 characters.
43	Magnetrol S/N	Transmitter Display	Shows MAGNETROL Serial Number for reference.
44	Model R82 version	Transmitter Display	Base Model Number with Communication type (HT = HART) Firmware Version and Date.
45	Factory Params	Enter to display Factory Parameters	Enter to display Factory Parameters. This section displays twenty-nine screens. The History screens are of particular importance to the user as they show a listing of chronological, diagnostic events, most recent first.

2.6.6.3 Radar Transmitter User Menu—Flow and Level

Note: Press UP arrow 5 times to reach screen where menu language can be chosen.

	Display	Action	Comment
1	<p>*Status*</p> <p>*Level*</p> <p>*Flow*</p> <p>*Head*</p> <p>*Distance*</p> <p>*Echo Str xx*</p> <p>*%Output*</p> <p>*Loop Current*</p> <p>*Local Tag*</p> <p>*Totalizer R*</p> <p>*Totalizer NR*</p>	Transmitter Display	<p>Transmitter default display: Status, Level, Flow, Head, Distance, Echo Strength, % Output, Loop Current, Local Tag, and Totalizer values advance every 2 seconds. All screens (except 2-11) default to this screen after 5 minutes of no keystrokes or if a Fault or Warning message is displayed.</p> <p>Default display will also show the highest priority Fault or Warning. If more than one Fault or Warning exists they will be displayed in the History screen (Item #2, Section 2.6.6.4 <i>Radar Transmitter Factory Menu</i> on Page 40) in chronological order.</p> <p>To Add/Remove what information is shown in default display:</p> <ul style="list-style-type: none"> • Go to specific parameter in question (screens 2-11) • Press Enter • Choose On or Off • Press Enter to confirm
2	<p>Level</p> <p>xxx.x units</p>	Transmitter Display	Transmitter displays Level measurement in chosen unit of measure.
3	<p>Flow</p> <p>xxx.x units</p>	Transmitter Display	Transmitter displays Flow measurement in chosen unit of measure.
4	<p>Head</p> <p>xxx.x units</p>	Transmitter Display	Head is defined as the measurement between Zero flow and Maximum flow. It is shown in user-selected Level Units.
5	<p>Distance</p> <p>xxx.x units</p>	Transmitter Display	Transmitter displays Distance measurement in chosen unit of measure; measurement includes Sensor Offset value. This value may not represent reciprocal of Level if the liquid level is within the Blocking Distance or Level Offset where the Level value is clamped.
6	<p>Echo Strength xx</p> <p>xxx.x units</p>	Transmitter Display	Transmitter display showing Level and Echo Strength of signal reflection. Good values are 20-99.
7	<p>% Output</p> <p>xx.x%</p>	Transmitter Display	Transmitter displays % Output measurement derived from 20 mA span.
8	<p>Loop Current</p> <p>xx.xx mA</p>	Transmitter Display	Transmitter displays Loop Current value (mA).
9	<p>Local Tag</p> <p>xxxxxxxxxxxx</p>	Transmitter Display	Transmitter displays Local Tag information.
10	<p>Totalizer</p> <p>(Resettable)</p>	Transmitter Display	Transmitter displays current value of the Resettable Totalizer.
11	<p>Totalizer</p> <p>(Non-Resettable)</p>	Transmitter Display	Transmitter displays current value of the Non-Resettable Totalizer.
12	<p>Measure Type</p> <p>(select)</p>	Select Type of Measurement	<p>Select Level Only or Flow & Level, Volume & Level, Flow, Flow Units, Volume, Volume Units, Loop Control, and Strapping Table screens appear when necessary. Note that the Flow or Volume screens are selected for rotation when Measure Type is set to Flow & Level or Volume & Level and is deselected when Measure Type is set to Level Only.</p> <p>See Section 2.6.6.1 for the complete Level menu or 2.6.6.2 for the complete Volume and Level menu.</p>
13	<p>Level Units</p> <p>(select)</p>	Select Units of measure	Select cm (xxxx), meters (xx.xx), inches (xxx.x), or feet (xx.xx). Allowable decimal position is controlled; four characters is maximum reading. Decimal position is controlled by Units and Tank Height.
14	<p>Range</p>	Enter the Range value	Range is measured from the bottom of the antenna threads to the bottom of the flow element.

2.6.6.3 Radar Transmitter User Menu—Flow and Level (cont.)

Note: Press UP arrow 5 times to reach screen where menu language can be chosen.

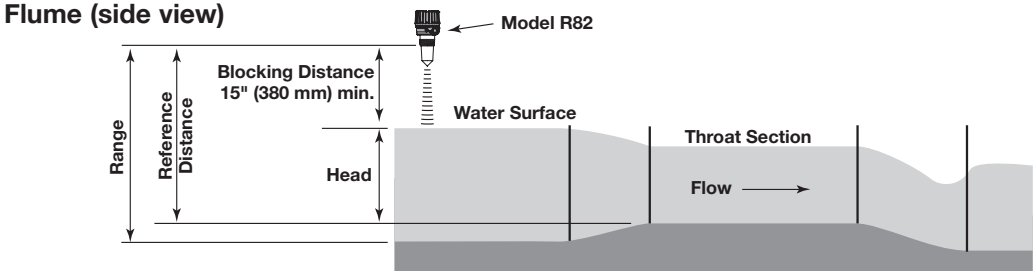
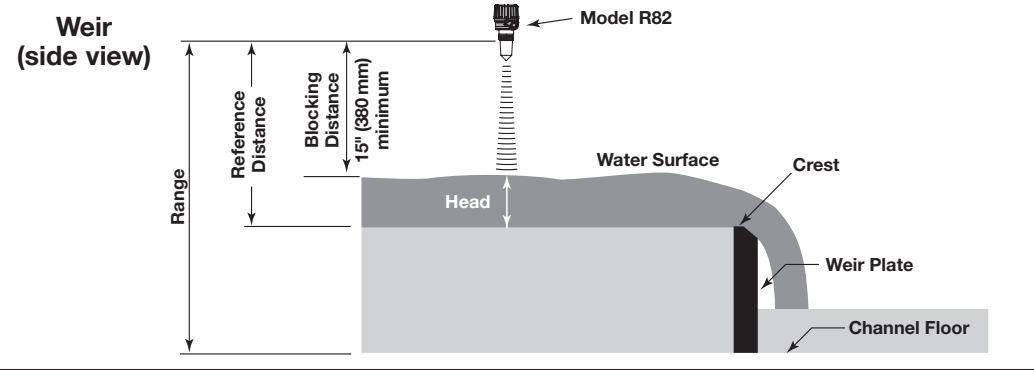
	Display	Action	Comment
15	Blocking Distance (xxx.x)	Enter the Blocking Distance	Blocking Distance defines an area near the antenna where reflections can not be measured effectively due to antenna ringing. It is measured from the Sensor Reference point. Default of 15" (380 mm) minimum distance from the process connection to the maximum level. Extend this value when necessary to block reflections from objects close to the antenna. Output will be held at value corresponding to Blocking Distance. Do not allow liquid into the Blocking Distance as false readings can result.
16	Level Offset (xxx.x units)	Enter the Level Offset	Level Offset defines an area at the bottom of the vessel where reflections can not be measured effectively due to angled bottoms, heating coils, reflections from flat metal tank bottoms in low dielectric applications, etc. It is the distance from the bottom of the tank to the lowest valid level reading. Level reading will never be lower than Level Offset value.
17	Flow Setup (continued on next page)	<p>Flume (side view)</p>  <p>Weir (side view)</p>  <p>Enter the Flow Information</p> <p>Flow Units</p>	<p>The following table provides an explanation of each of the System Configuration parameters for open channel flow applications using one of the Flow Elements that are stored in the firmware. See below and Pgs. 9–11 for dimensional information on the flumes and weirs.</p> <p>A selection of Gallons/Minute (factory default Flow Unit), Gallons/Hour, Mil Gallons/Day, Liters/Second, Liters/Minute, Liters/Hour, Cubic Meter/Hour, Cubic Ft/Second, Cubic Ft/Minute, and Cubic Ft/Hour are provided. Should some other units of flow be desired, the Custom Unit feature can be used in the Advanced Configuration Menu.</p>

2.6.6.3 Radar Transmitter User Menu—Flow and Level (cont.)

Note: Press UP arrow 5 times to reach screen where menu language can be chosen.

	Display	Action	Comment
17	Flow Setup (continued from previous page) (continued on next page)	Flow Element	Select one of the following primary Flow Elements that are stored in the firmware: Parshall flume sizes of 6", 9", 12", 18", 24", 36", 48", 60", 72", 96", 120" and 144" . Palmer-Bwls (Palmer-Bowlus) flume sizes of 4", 6", 8", 10", 12", 15", 18", 21", 24", 27" and 30" . V-notch weir sizes of 22.5°, 30°, 45°, 60°, 90° and 120° . Rect with Ends (Rectangular Weir with End Contractions), Rect w/o Ends (Rectangular Weir without End Contractions), and Cipoletti weir.
		Crest Length	The <i>Crest Length</i> screen only appears when the chosen <i>Flow Element</i> is Cipoletti or one of the <i>Rectangular</i> weirs. Input this length in the user-selected level units.
		Reference Dist	The <i>Reference Distance</i> is measured from the bottom of the antenna threads to the point of zero flow in the weir or flume. This must be measured very accurately in the userselected level units. For some <i>Flow Elements</i> , such as <i>Parshall</i> flumes, the <i>Reference Dist</i> is the same as the <i>Range</i> value. Weirs and some other Flow Elements will have a <i>Reference Distance</i> that is shorter than the <i>Range</i> value.
		Maximum Head	<i>Maximum Head</i> is the highest liquid level (Head) value in the flume or weir before the flow equation is no longer valid. The <i>Maximum Head</i> is expressed in the user selected <i>Level Units</i> . The R82 will default to the largest <i>Maximum Head</i> value that is allowed for any given flume or weir. The <i>Maximum Head</i> value can be revised depending on the value of the <i>Reference Distance</i> , or for end user preference.
		Maximum Flow	<i>Maximum Flow</i> is a read-only value that represents the flow value corresponding to the <i>Maximum Head</i> value for the flume or weir.
		Low Flow Cutoff	The <i>Low Flow Cutoff</i> (in user-selected level units) will force the calculated flow value to zero whenever the Head is below this point. This parameter will have a default and minimum value of zero.
		Totalizers: Units	The <i>Totalizer Units</i> screen is for selection of the units for both the resettable and non-resettable totalizers. Select Gallons (factory default unit), Mil Gallons , Liters , Mil Liters , Cubic Meters , or Cubic Feet .
		Totalizers: Total NR Mult	The <i>Total NR Mult</i> screen allows selection of the multiplier to be used for the non-resettable totalizer. The function of the totalizer multiplier is such that if the chosen units are gallons and the multiplier is 100, the totalizer value will increment one whole unit for each 100 gallons. Select 1 , 10 , 100 , 1,000 (default), 10,000 or 100,000 .
		Totalizers: Totalizer NR	This is a read only screen that displays the present value of the non-resettable totalizer.
		Totalizers: Total NR Time	This is a read only screen that displays the time that has elapsed since the non-resettable totalizer has been totalizing flow.

2.6.6.3 Radar Transmitter User Menu—Flow and Level (cont.)

Note: Press UP arrow 5 times to reach screen where menu language can be chosen.

	Display	Action	Comment						
17	Flow Setup (continued from previous page)	Totalizers: Total R Mode	<i>Total R Mode</i> allows the user to enable and disable the resettable totalizer. The default mode is disabled.						
		Totalizers: Total R Mult	The <i>Total R Mult</i> screen allows selection of the multiplier to be used for the resettable totalizer. The function of the totalizer multiplier is such that if the chosen units are gallons and the multiplier is 100, the totalizer value will increment one whole unit for each 100 gallons. Select 1, 10, 100, 1,000 (default), 10,000 or 100,000 .						
		Totalizers: Totalizer R	This is a read-only screen that displays the present value of the resettable totalizer.						
		Totalizers: Totalizer R Time	This is a read-only screen that displays the time that has elapsed since the resettable totalizer has been totalizing flow.						
		Totalizers: Totalizer R	The <i>Totalizer R Reset</i> screen allows the user to reset the total flow and elapsed time of <i>Totalizer R</i> to zero (<i>Totalizer NR</i> is non-resettable). Since this action will permanently lose this data, a second chance is provided with an “Are you sure?” screen.						
18	Flow Generic Equation	Enter Flow Information Using Generic Equation	Generic Eqn Factors <i>Generic Equation</i> is a discharge flow equation in the form of $Q = K(L-CH)H^n$, where $Q =$ flow (Cu Ft/Second), $H =$ Head (Feet), $K =$ a constant, and L, C and n are user input factors that depend on which Flow Element is being used. Make sure the flow equation is in the form of $Q = K(L-CH)H^n$, and proceed to enter the values of K, L, C, H and n .						
		<table border="1" data-bbox="495 1087 1511 1199"> <thead> <tr> <th colspan="3">Generic Equation Example (using equation for an 8' rectangular weir w/ end contractions)</th> </tr> </thead> <tbody> <tr> <td>$Q =$ Cubic Ft/Second flow rate</td> <td>$L = 8'$ (weir crest length in feet)</td> <td>$H =$ Head value</td> </tr> <tr> <td>$K = 3.33$ for Cubic Ft/Second units</td> <td>$C = 0.2$ (constant)</td> <td>$n = 1.5$ as an exponent</td> </tr> </tbody> </table> <p data-bbox="527 1220 820 1266">$Q = K(L-CH)H^n$</p> <p data-bbox="527 1276 1047 1308">Using the factors above, the equation becomes:</p> <p data-bbox="527 1318 755 1350">$Q = 3.33 (8-0.2H) H^{1.5}$</p> <p data-bbox="527 1360 1502 1455">The discharge flow value for a Head value of 3 feet becomes 128.04 Cubic Ft/Second. If GPM was selected for the Flow Units, the R82 Measured Values screen would display this value converted to 57,490 GPM.</p>	Generic Equation Example (using equation for an 8' rectangular weir w/ end contractions)			$Q =$ Cubic Ft/Second flow rate	$L = 8'$ (weir crest length in feet)	$H =$ Head value	$K = 3.33$ for Cubic Ft/Second units
Generic Equation Example (using equation for an 8' rectangular weir w/ end contractions)									
$Q =$ Cubic Ft/Second flow rate	$L = 8'$ (weir crest length in feet)	$H =$ Head value							
$K = 3.33$ for Cubic Ft/Second units	$C = 0.2$ (constant)	$n = 1.5$ as an exponent							

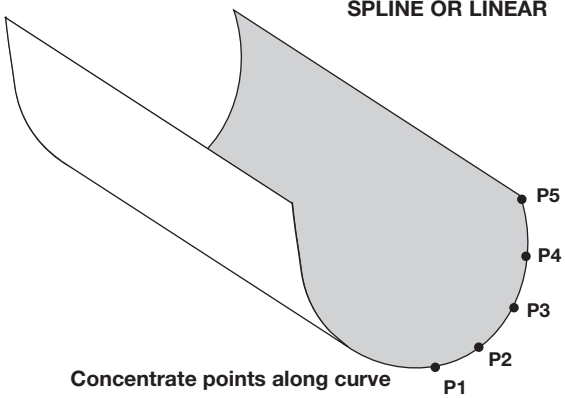
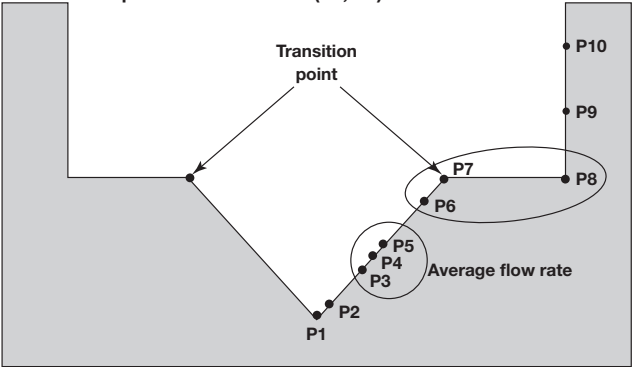
	Display	Action	Comment
19	Flow Custom Table	Custom Table Type	<p>The following table provides an explanation of each of the System Configuration parameters for open channel flow applications using the Custom Table.</p> <div data-bbox="885 405 1446 800"> <p style="text-align: center;">SPLINE OR LINEAR</p>  <p style="text-align: center;">Concentrate points along curve</p> </div> <p>Concentrate points as follows:</p> <ul style="list-style-type: none"> A. At least two points at beginning (P1 and P2); B. At least two points at end (P9 and P10); C. Three points at approximate average flow rate (for example, P3, P4, P5); and at transition point (P7) and points on either side (P6, P8). <div data-bbox="846 961 1474 1325">  </div> <p>The <i>Custom Table</i> points can be a Linear (straight line between adjacent points) or Spline (can be a curved line between points) relationship.</p>
		Custom Table Values	<p>A maximum of 20 points can be used in building the <i>Custom Table</i>. Each pair of values will have a Head (height) in the units chosen in the <i>Level Units</i> screen, and the associated flow for that Head value. The values must be monotonic (i.e., each pair of values must be greater than the previous Head/flow pair). The last pair of values should have the highest Head value (usually the <i>Maximum Head</i> value) and the flow associated with that Head value.</p>

2.6.6.3 Radar Transmitter User Menu—Flow and Level (cont.)

Note: Press UP arrow 5 times to reach screen where menu language can be chosen.

	Display	Action	Comment
20	Dielectric (select)	Enter the Dielectric range value	1.7-3.0; 3.0-10.0; 10.0-100.0
21	Turbulence (select)	Select amount of Turbulence of the liquid	None, Light, Medium, Heavy. Increase selection if Echo is often lost or Echo Strength is <20.
22	Foam (select)	Select amount of Foam	None, Light, Medium, Heavy. Increase selection if Echo is often lost or Echo Strength is <20.
23	Rate of Change (select)	Select Rate of Change of the liquid	Select the maximum rate of change of the level surface, rising or falling, in inches (cm)/minute; <5 (13), 5-20 (13-50), 20-60 (50-150), >60 (150)
24	Echo Profile	<p>Press Enter to</p> <ul style="list-style-type: none"> - Review all Echoes - Run a new Echo Rejection Profile - Review an existing Echo Rejection Profile 	<p>1.) Echo List Mode- Choose to review echoes in Distance or Level</p> <p>2.) Review all echoes using UP/DOWN arrows; listed in descending Level value</p> <p>3.) To run a new Echo Rejection Profile</p> <ul style="list-style-type: none"> a.) Choose the echo that corresponds to the actual liquid level b.) Press ENTER and confirm a new Echo Rejection profile should be run. If necessary, Press ESCAPE to exit at any time. <p>NOTES:</p> <ul style="list-style-type: none"> - ECHO REJECTION should run with vessel at or near empty when all targets are exposed - Re-run this routine if initial calibration is done with significant liquid in vessel - The Echo Rejection profile will be disabled and this routine must be re-run if the following parameters are modified: SENSOR OFFSET, TANK HEIGHT, BLOCKING DISTANCE, DIELECTRIC, TURBULENCE, FOAM - The EchoRej Invalid message will be displayed if this algorithm is DISABLED due to a parameter change. <p>4.) Enter Level- use this entry to manually enter the correct level value</p> <p>Error messages:</p> <p>“Echo too Close” indicates the liquid is too close to the antenna. Liquid should not be closer than 30” (750 mm).</p> <p>“Echo too Strong” indicates an echo being rejected is too strong.</p> <ul style="list-style-type: none"> a.) Ensure it is not the actual liquid level b.) Rotate the Launcher to minimize the echo <p>5.) Saved Echo Rejection Profile-</p> <ul style="list-style-type: none"> a.) Enable or Disable an existing profile b.) Review Echoes from an existing profile c.) Review Level value where existing profile was run

2.6.6.3 Radar Transmitter User Menu—Flow and Level (cont.)

Note: Press UP arrow 5 times to reach screen where menu language can be chosen.

	Display	Action	Comment
25	Loop Control (select)	Select mode for Loop Control	Select Level or Flow.
26	4 mA Set Point (xxx.x units)	Enter the value for the 4 mA point	During normal operation, mA value will clamp at boundary defined by the Level Offset value (refer to #16).
27	20 mA Set Point (xxx.x units)	Enter the value for the 20 mA point	During normal operation, mA value will clamp at boundary defined by the Blocking Distance value (refer to #15).
28	Damping (xx sec)	Enter the Damping factor	A damping factor (0-45) may be added to smooth a noisy display and/or output due to turbulence.
29	System Fault (select)	Select the System Fault value	Select 3.6 mA, 22 mA or HOLD (last value).
30	Echo Loss Fault (select)	Select the Echo Loss Fault value	Select 3.6 mA, 22 mA or HOLD (last value).
31	Echo Loss Delay (xxx sec)	Enter the value for the Echo Loss Delay	Select a value 0-1000; 30 is default.
32	Safe Zone Fault (select)	Select the Safe Zone Fault	Safe Zone is a user-defined area just below the Blocking Distance. Set this Fault if it necessary to ensure safe, reliable high-level readings in critical applications. Choices are None, 3.6 mA, 22 mA, Latch 3.6 or Latch 22. If Latch 3.6 or Latch 22 is chosen, the loop current will remain in alarm until it is cleared by customer in SZ Latch below (refer to #34).
33	Safe Zone Height (xx.x units)	Enter a Safe Zone Distance	Enter a distance value that develops a zone just below the Blocking Distance. At this point the unit will report a Safety Zone Fault (refer to #32) if the level rises into this area.
34	Safe Zone Alarm (Reset)	Clear Safe Zone Alarm	Clear a latched Safe Zone alarm.
35	Trim Level (xxx.x units)	Enter a Trim Level value	Trim Level is an offset value to be used to force the transmitter to output the proper Level. This should only be used after Tank Height and Sensor Offset have been confirmed as correct. -24 to +24 inches (-61 to +61 cm).
36	Stillwell I.D. (xx.x units)	Enter Pipe I.D.	For measuring in a stillwell. Enter a value for inside diameter of the pipe (presently only 2" (50mm) is acceptable). Range of values 0, 3-20 inches (0, 40-500 mm). Value must be left as 0 if no standpipe/stillwell is present.
37	Trim 4 mA	Fine tune the 4mA point	Attach a mA meter to the output. If the output does not equal 4.00 mA, adjust the value on the display until meter reads 4.00 mA. This is not for setting the 4mA point (refer to #26).

2.6.6.3 Radar Transmitter User Menu—Flow and Level (cont.)

Note: Press UP arrow 5 times to reach screen where menu language can be chosen.

	Display	Action	Comment
38	Trim 20 mA	Fine tune the 20mA point	Attach a mA meter to the output. If the output does not equal 20.00 mA, adjust the value on the display until meter reads 20.00 mA. This is not for setting the 20mA point (refer to #27).
39	Test 4–20 Loop (xx.xx mA)	Enter a mA Output value	This screen serves two functions: 1.) Calibrate Loop: Enter mA output value to send a constant current. Present current will be returned upon exiting screen 2.) Check for sufficient loop voltage @20mA: a.) Drive current value to 4.00mA b.) Drive current value to >10mA c.) Press ENT; top line of display will show - (???) if done incorrectly - (OK) if sufficient VDC is calculated - (Low) if insufficient VDC is calculated d.) Bottom line of display will show calculated loop voltage at 20mA
40	Hart Poll Addr (xx)	Select HART Poll Address number	Select HART Poll Address number. Select a HART Poll Address (0-15). Enter 0 for a single transmitter installation; enter 1-15 for multi-drop HART network.
41	New Password (enter)	Enter new Password	Enter the desired Password value between 0 and 255; 0 = No Password. During normal operation an encrypted password is shown. Consult factory to decrypt this value, if necessary.
42	Configuration Reset	Enter to Reset Parameters	Reset configuration parameters to factory default values.
43	Language (select)	Select Language	Select Language that will be displayed on the transmitter screen. English, Espanol, Deutsch and Francais.
44	Input Local Tag (enter)	Enter Local Tag	Local Tag can be a maximum of 12 characters.
45	Magnetrol S/N	Transmitter Display	Shows MAGNETROL Serial Number for reference.
46	Model R82 version	Transmitter Display	Base Model Number with Communication type (HT = HART) Firmware Version and Date.
47	Factory Params	Enter to display Factory Parameters	Enter to display Factory Parameters. This section displays twenty-nine screens. The History screens are of particular importance to the user as they show a listing of chronological, diagnostic events, most recent first.

2.6.6.4 Radar Transmitter Factory Menu

	Display	Action	Comment
1	Factory Params	Select Enter to reveal Factory Parameters; Back to escape.	Review Factory parameters
2	History		Displays history of diagnostic information - Main screen displays active message - Press Enter to display chronological listing of diagnostic events - Use Up/Down arrows to view list of events - Press Enter when viewing an event to see its timing information - Press Up/Down arrows to view Occured or Duration NOTE: Times are measured from moment of power-up, displayed in seconds or tenths of an hour - Press Back to exit
3	Run Time	Display Run Time	Displays elapsed time since most recent power-up.
4	History Reset	Reset History	Press Enter to clear diagnostic information in History and reset Run Time to zero.
5	System Code	Displays System Code errors	Diagnostic, factory setting
6	Elec Temperature	Display Electrical Temperature	Displays current temperature on circuit board.
7	Max Temperature	Display Max Temperature	Displays maximum temperature recorded for circuit board.
8	Min Temperature	Display Min Temperature	Displays minimum temperature recorded for circuit board.
9	VDC Chk Midpoint	None, do not adjust	Diagnostic factory setting
10	Antenna Mount	None, do not adjust	Diagnostic factory setting
11	Echo Profile	None, do not adjust	Diagnostic factory setting
12	Target Algorithm	None, do not adjust	Diagnostic factory setting
13	TVG Minimum	None, do not adjust	Diagnostic factory setting
14	TVG Maximum	None, do not adjust	Diagnostic factory setting
15	Peak Detect Ref	None, do not adjust	Diagnostic factory setting
16	Peak Detect Thresh	None, do not adjust	Diagnostic factory setting
17	Min Threshold	None, do not adjust	Diagnostic factory setting
18	# Run Average	None, do not adjust	Diagnostic factory setting
19	# Adap Average	None, do not adjust	Diagnostic factory setting
20	Scatter HiLimit	None, do not adjust	Diagnostic factory setting
21	Rate HiLimit	None, do not adjust	Diagnostic factory setting
22	Scatter Rate	None, do not adjust	Diagnostic factory setting
23	Lvl ROC Per Min	None, do not adjust	Diagnostic factory setting
24	Max ROC Per Min	None, do not adjust	Diagnostic factory setting
25	Max Distance Jump	None, do not adjust	Diagnostic factory setting
26	Boundary State	None, do not adjust	Diagnostic factory setting
27	EmptyState Delay	None, do not adjust	Diagnostic factory setting
28	NSPValue	None, do not adjust	Diagnostic factory setting
29	HART Device ID	None, do not adjust	Diagnostic factory setting
30	Factory Calib	None, do not adjust	Diagnostic factory setting
31	Window	None, do not adjust	Diagnostic factory setting
32	Target Distance	None, do not adjust	Diagnostic factory setting
33	Conversion Factor	None, do not adjust	Diagnostic factory setting
34	Scale Offset	None, do not adjust	Diagnostic factory setting
35	System Gain	None, do not adjust	Diagnostic factory setting

2.7 Configuration Using HART®

A HART® (Highway Addressable Remote Transducer) remote unit, such as a HART communicator, can be used to provide a communication link to the Model R82 transmitter. When connected to the control loop, the same system measurement readings shown on the transmitter are shown on the communicator. In addition, the communicator can be used to configure the transmitter.

To confirm HART hand-held communications, attach unit per Section 2.7.1. If communicator reads **GENERIC** on first two lines, the HART hand-held does not contain the current DDs (device description) for the Model R82 Radar transmitter. Contact your local HART Service Center and specify a MAGNETROL Model R82 device descriptor.

See HART Revision Table, Section 2.7.3.

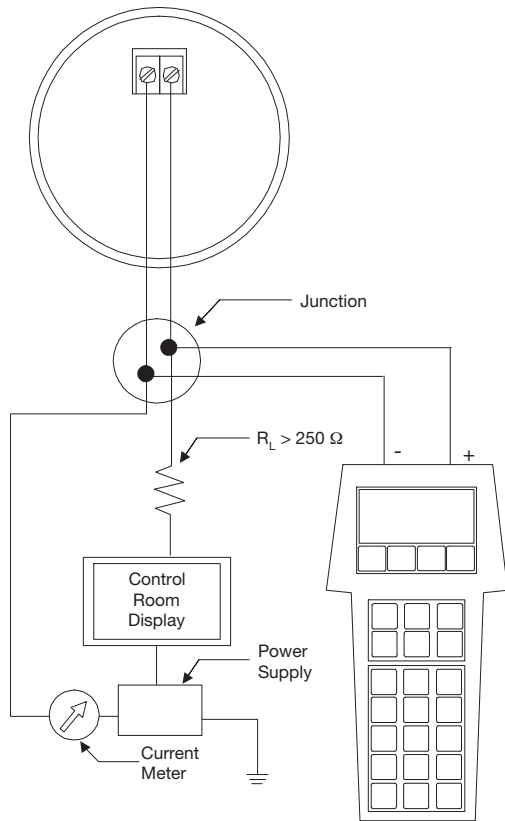

Figure 28
HART Configuration

2.7.1 Connections

A HART communicator can be operated from a remote location by connecting it to a remote junction or by connecting it directly to the terminal block in the electronics housing of the Model R82 transmitter.

HART uses the Bell 202 frequency shift key technique of high-frequency digital signals. It operates on the 4–20 mA loop and requires 250 Ω load resistance. A typical connection between a communicator and the Model R82 transmitter is illustrated.

2.7.2 Display Menu

A typical communicator display is an 8-line by 21-character LCD. When connected, the top line of each menu displays the model (Model R82) and its tag number or address. Usually the bottom line of each menu is reserved for software-defined function keys (F1–F4). For detailed operating information, refer to the instruction manual provided with the HART communicator.

The Model R82 transmitter online menu trees are shown in the following illustration. Open the menu by pressing the alphanumeric key 1, Device Setup, to display the second-level menu.

2.7.3 Model R82 HART Revision Table

HART Version	HCF Release Date	Compatible with R82 Software
Dev V2, DD V2	April 2009	Version 1.0a-1.1a
Dev V3, DD V1	December 2010	Version 2.0a and later

2.7.4 HART Menu – Level Only

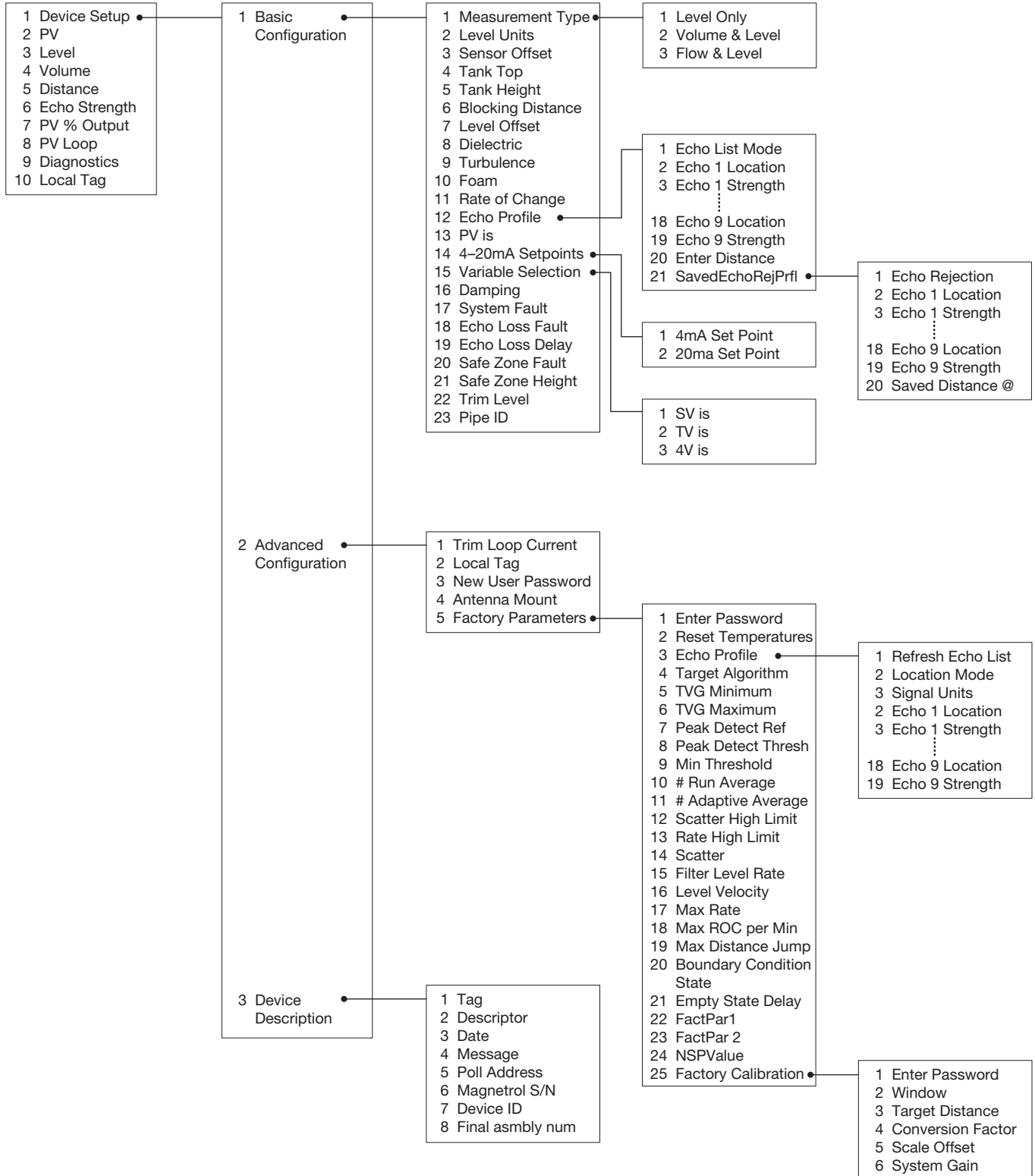

2.7.4 HART Menu – Level Only

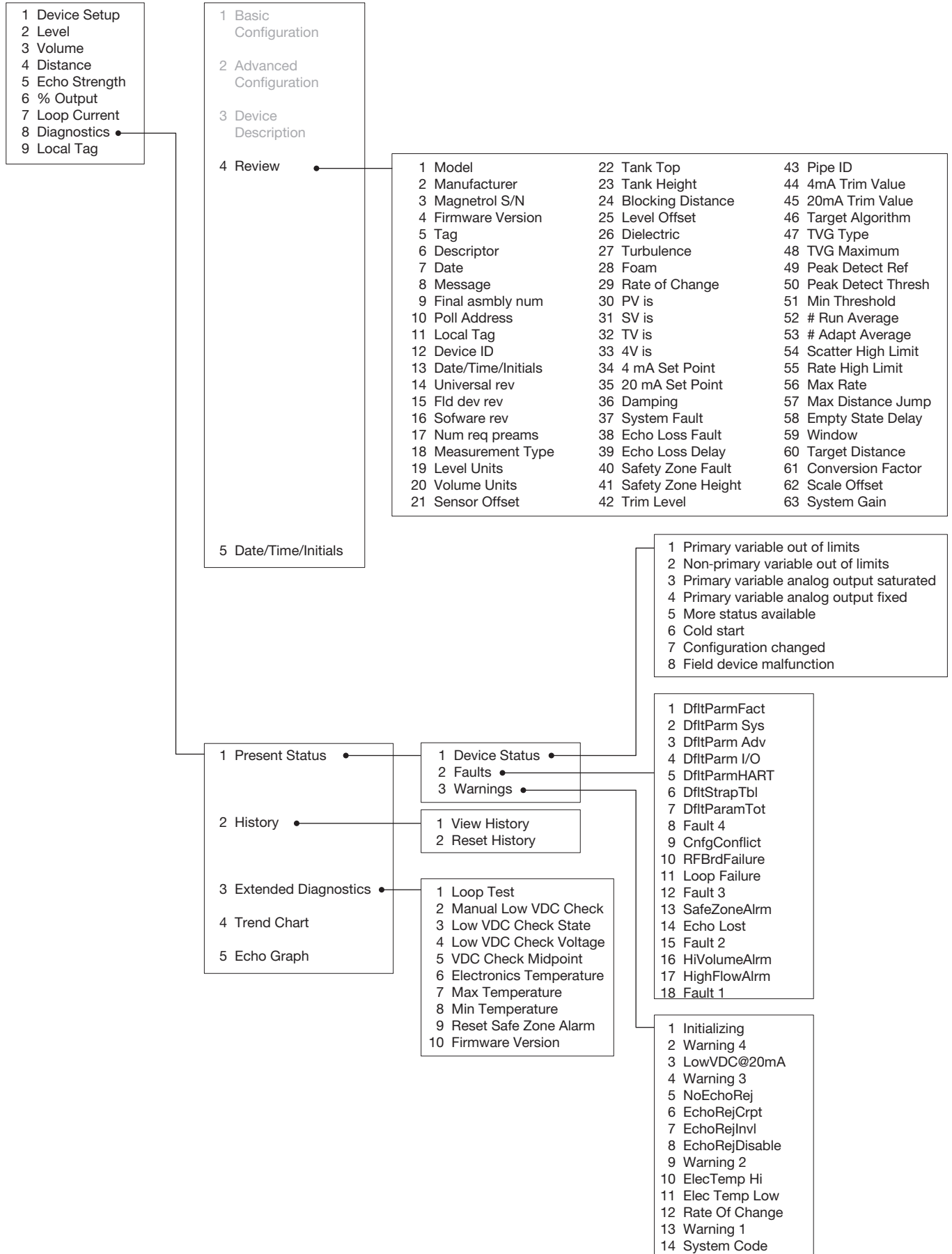

2.7.5 HART Menu – Volume & Level and Volume & Flow

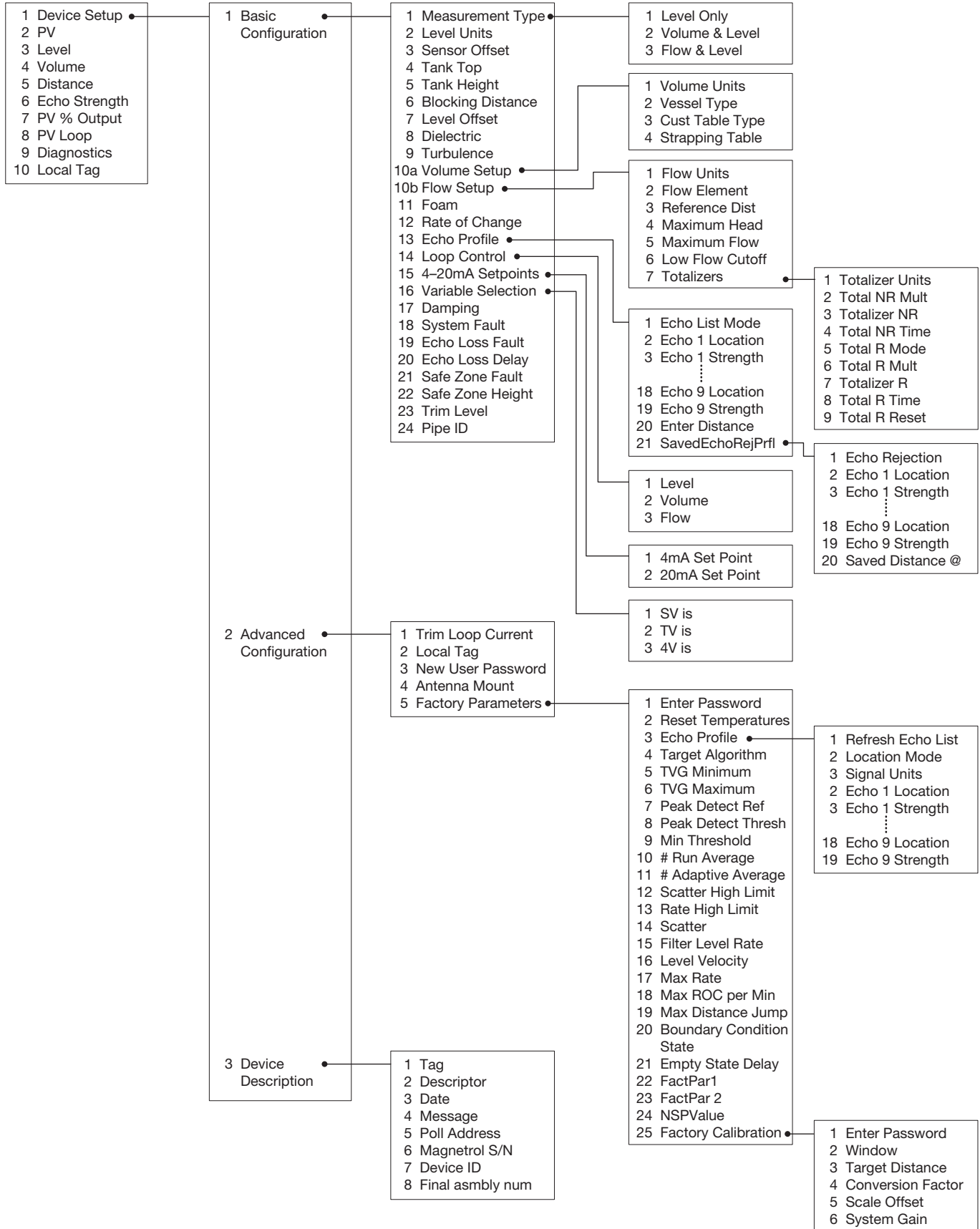

2.7.5 HART Menu – Volume & Level and Volume & Flow

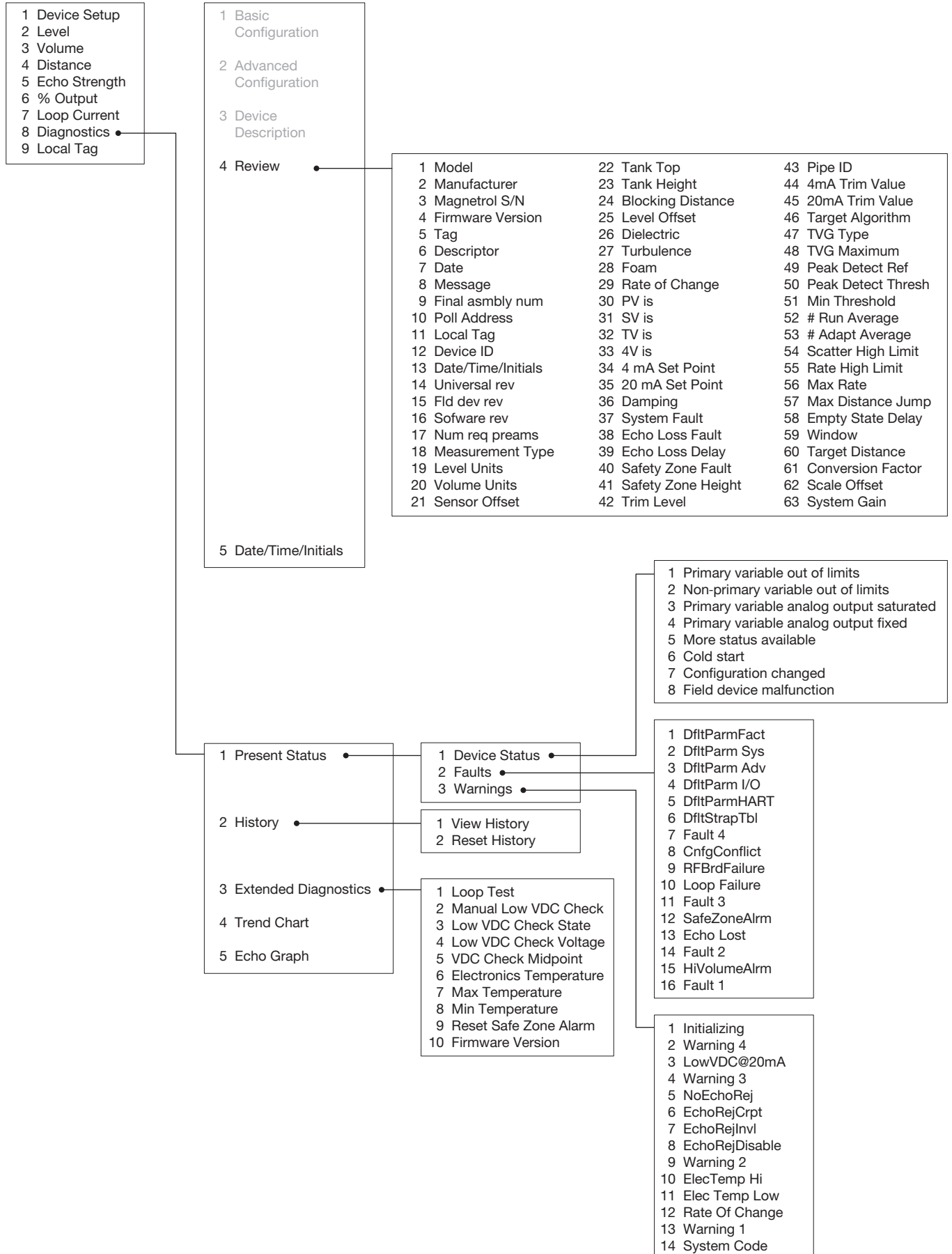

3.0 Reference Information

This section presents an overview of the operation of the Model R82 Radar Level Transmitter, information on troubleshooting, common problems, listings of agency approvals, lists of replacement and recommended spare parts, and detailed physical, functional and performance specifications.

3.1 Description

The Model R82 is a two-wire, 24 VDC level transmitter based on the concept of pulse burst radar operating at 26 GHz. The electronics are mounted in a metal or plastic housing with an innovative, internal launcher orientation mechanism.

3.2 Theory of Operation

3.2.1 Pulse Burst Radar

The Model R82 is a top-mounted, downward-looking pulse burst radar operating at 26 GHz. Unlike true pulse devices that transmit a single, sharp (fast rise-time) waveform of wide-band energy, the R82 emits short bursts of 26 GHz energy and measures the transit time of the signal reflected off the liquid surface. Distance is calculated utilizing the equation $\text{Distance} = C \times \text{Transit time} / 2$, then developing the Level value by factoring in Tank Height and Sensor Offset information. The exact reference point for distance and level calculations is the Sensor Reference Point—bottom of an NPT thread, top of a BSP thread or face of a flange.

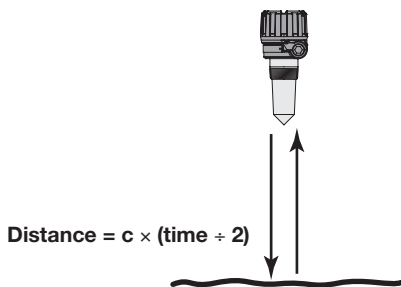
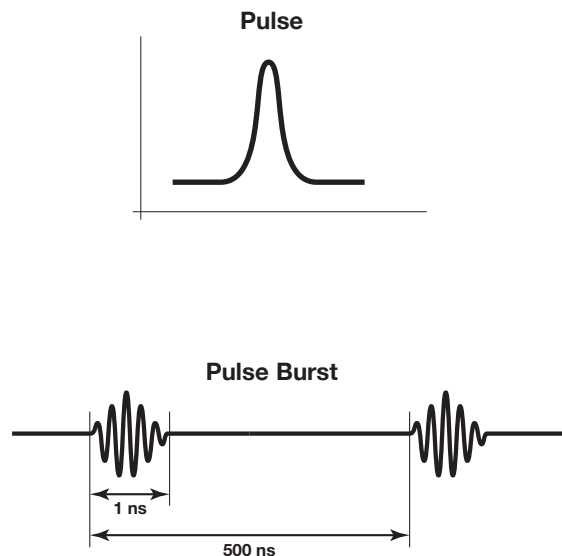

Figure 29

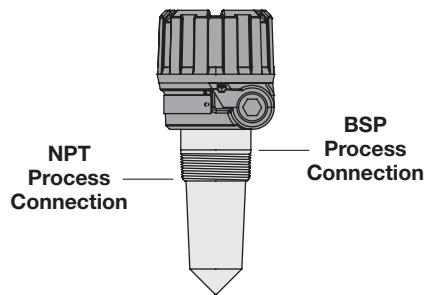

Figure 30
Sensor Reference Point

The exact level measurement is extracted from false echo reflections and other background noise via the use of sophisticated signal processing. The new R82 circuitry is extremely energy efficient so no duty cycling is necessary to accomplish effective measurement. For this reason, the R82 can track high rates of change that were heretofore impossible with existing loop-powered radar transmitters.

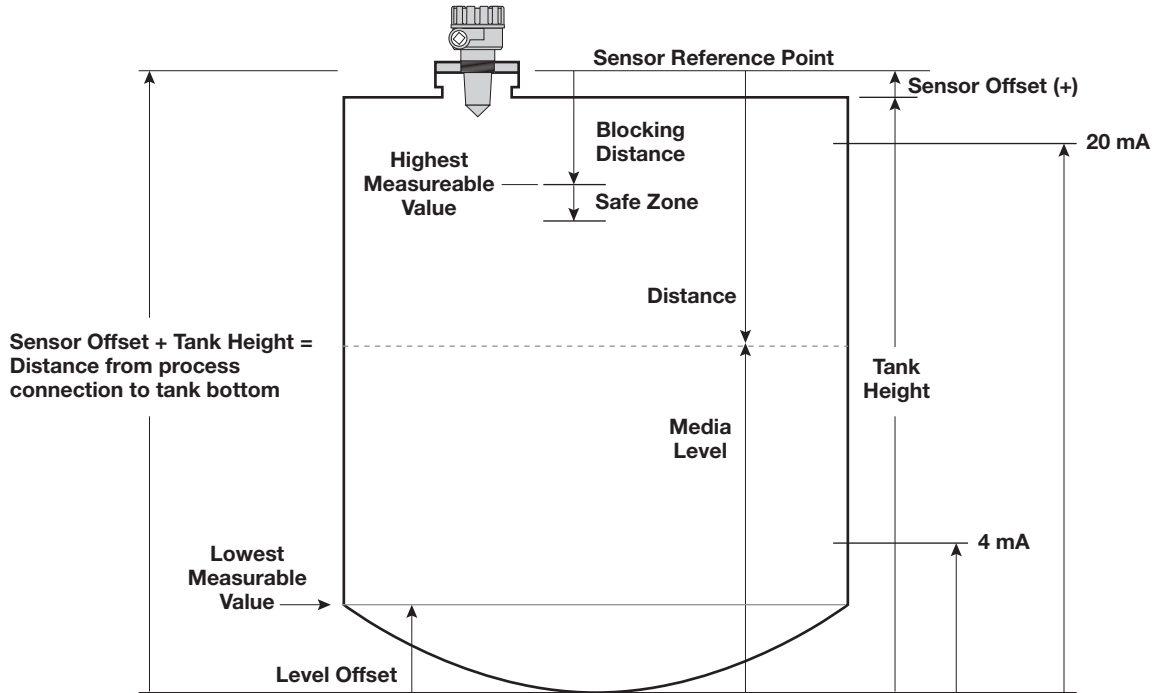

Figure 31

3.2.2 Equivalent Time Sampling

ETS, or Equivalent Time Sampling, is used to measure the high speed, low power EM (electromagnetic) energy. ETS is a critical key in the application of Radar to vessel level measurement technology. The high speed electromagnetic energy (1 ft/nS) is difficult to measure over short distances and at the resolution required in the process industry. ETS captures the EM signals in real time (nanoseconds) and reconstructs them in equivalent time (milliseconds), which is much easier to measure with today's technology.

ETS is accomplished by scanning the tank to collect thousands of samples. The round-trip event on a 40-foot (12.3m) tank takes only 82 nanoseconds in real time. After it is reconstructed in equivalent time it measures 135 milliseconds.

3.3 Troubleshooting

The Model R82 transmitter is designed and engineered for trouble-free operation over a wide range of operating conditions. Common transmitter problems are discussed in terms of their symptoms and recommended corrective actions.

WARNING! Explosion hazard. Do not remove covers unless power has been switched off or the area is known to be non-hazardous.

Use of the included PACTware™ PC program is highly recommended and invaluable for troubleshooting and advanced calibration. A HART RS232 or USB modem (purchased separately) is required. See MAGNETROL PACTware™ bulletin 59-101.

3.3.1 Troubleshooting System Problems

Symptom	Problem	Solution
Level reading drops out at a repeatable position in the vessel	Multipath is cancelling good level signal	Orient launcher to reduce multipath; turn launcher 10–20 degrees (1–2 index marks) at a time until multipath at this point disappears. Refer to Section 2.4.2.3
Level reading locked onto a value that is not correct	Measurement engine finding a reflection it believes is level signal	1. Is high dielectric ($\epsilon > 10$) foam present? 2. Run Echo Rejection routine with Level below this point (or with Empty tank) to eliminate false echoes
LEVEL, % Output and LOOP values are all inaccurate	Basic configuration data questionable	1. Check validity of all configuration data 2. Check DISTANCE value of device against manually measured distance
LEVEL readings are repeatable but consistently high (or low) from actual by a fixed amount	Configuration data does not accurately match tank dimensions	1. Ensure proper values for Tank Height and Sensor Offset 2. Check vessel for present liquid level. Trim Level can be used to ensure exact measurement 3. Reconfigure LOOP values if necessary
LEVEL reading on Display is correct but LOOP is stuck at 4 mA	HART Poll Address set a value of 1-15	Set HART Poll Address to 0
LEVEL reading on Display stuck at value related to Blocking Distance	Device believes antenna is flooded (level very near or on antenna)	Check actual level. If antenna is not flooded, power down, then power up transmitter with the level well below the antenna.

3.3.2 Error Messages

The Model R82 Radar transmitter utilizes a 3-section hierarchy for reporting diagnostic conditions: FAULTS, WARNINGS, and INFORMATION. FAULTS and WARNINGS will be shown in the Home screen when the message is active. A chronological listing of messages can be viewed in the HISTORY screen.

FAULT: The highest level in the hierarchy of diagnostics annunciating a defect or failure in circuitry or software that precludes reliable measurement. The current (mA) value unit defaults to 3.6, 22, or HOLD and the Home screen will freeze showing the highest priority Fault. A chronological listing of messages can be viewed in the HISTORY screen.

WARNING (MESSAGE): The second level in the hierarchy of Diagnostics annunciating conditions that are not fatal but may affect measurement. The highest priority Warning will be placed on the main (rotating) screen when a Warning is detected but will not affect output current. A chronological listing of messages can be viewed in the HISTORY screen.

INFORMATION (MESSAGE): The lowest level in the hierarchy of diagnostic conditions providing operational factors that are not critical to measurement. A chronological listing of messages can be viewed in the HISTORY screen.

EFFECTS OF EACH DIAGNOSTIC MESSAGE

	mA Loop	Display Message	History Screen ①
Fault	3.6/22/HOLD	Yes	Yes
Warning	No Effect	Yes	Yes
Information	No Effect	No	Yes

① Also listed in History screen are changes of “state.” For example, “BC Level” which means Boundary Condition Level. This is an expression of the transmitter’s internal logic.

DIAGNOSTIC MESSAGES





	Symptom	Condition(s)	Solution(s)
Faults	DfltParmFact	Non-volatile memory corrupted	DfltParmFact: Consult Factory
	DfltParm Sys		DfltParm Sys: LEVEL UNITS
	DfltParm Adv		DfltParm Adv: DAMPING
	DfltParm I/O		DfltParm I/O: 4 mA SET POINT
	DfltParmHART		DfltParmHART: HART POLL ADDR
	DfltStrapTbl		DfltStrap Tbl: 1 Level Point in Strapping
	Dflt Param Total		Dflt Param Total: 1 point in Totalizer
	RFBrdFailure	Ramp interval out of tolerance	<ul style="list-style-type: none"> • Check for loose connection between boards • Consult Factory
	Loop Failure	The actual current generated in the 4-20 mA loop differs significantly (> 1 mA) from the intended loop current.	Consult Factory
	SafeZoneAlrm	<p>Level has risen to within SZ Height of Blocking Distance point.</p> <p>SZ Alarm notification choices:</p> <ul style="list-style-type: none"> i) 22 mA: loop driven to 22 mA while detected level remains within SZ Height of Blocking Distance point ii) 3.6 mA: loop driven to 3.6 mA while detected level remains within SZ Height of Deadband iii) Latch 22 mA: loop held at 22 mA until manually reset iv) Latch 3.6 mA: loop held at 3.6 mA until manually reset v) None: safety zone not enabled. (default Safety Zone Alarm state) 	<ul style="list-style-type: none"> • Normal operation • Change parameters to modify transmitter actions • Keep liquid from entering this area
	Echo Lost	No valid echo from the liquid surface has been received for a period exceeding the Echo Loss Delay.	<ul style="list-style-type: none"> • Increase Turbulence setting • Decrease Dielectric setting • Increase Foam setting • Increase ROC setting • Increase LOE Delay
	HiVolumeAlrm	The measured level exceeds the strapping table SPAN by more than 5%.	<ul style="list-style-type: none"> • Increase the maximum Level/Volume capability of the table • Prevent liquid from reaching this level
HighFlowAlrm	The calculated flow exceeds maximum flow by more than 5%.	Modify flow calculations or prevent liquid from reaching this level.	

continued on next page

DIAGNOSTIC MESSAGES (cont.)

	Symptom	Condition(s)	Solution(s)
Warnings	Initializing	Instrument is warming up	Normal operation
	LowVDC@20mA	Test_Power reading is so low that brownout may occur at high current values.	<ul style="list-style-type: none"> • Reduce resistance in loop • Increase power supply voltage
	No EchoRej	No Echo Rejection Profile has been saved	<ul style="list-style-type: none"> • Run new Echo Rejection Profile • Turn OFF Echo Rejection warning
	EchoRej Crpt	Non-volatile memory exception in Echo Rejection Profile partition	<ul style="list-style-type: none"> • Re-run Echo Rejection Profile • Consult Factory
	EchoRej Invl	A stored Echo Rejection Profile has been invalidated; typically because a key configuration parameter was changed.	Re-run Echo Rejection Profile
	EchoRej Dsbl	Echo Rejection has been disabled	<ul style="list-style-type: none"> • Enable Echo Rejection • Turn OFF Echo Rejection warning
	EchoRej Insf	Echo Rejection Curve ended within a partial Echo	Re-run Echo Rejection Profile at a higher or lower Level to avoid capturing a partial echo
	Elec Temp Hi	Electronics temperature presently above 80°C	Reduce exposure of transmitter to high temperature to avoid damage
	Elec Temp Lo	Electronics temperature presently below -40°C	Reduce exposure of transmitter to low temperature to avoid damage
	RateOfChange	Rate of level change has exceeded user setting for ROC.	Increase Rate of Change setting
Informational	System Code	Unexpected but non-fatal software condition has occurred	Consult Factory
	BC Initial BC Level BC Empty BC Full BC EchoMiss BC EchoLost BC Restart	Boundary Condition State	Normal operation
	NoTargetFound	Echo processing module detected no echoes above threshold	<ul style="list-style-type: none"> • Ensure proper installation • Ensure proper configuration-specifically Dielectric, Turbulence, Foam • Ensure proper application for radar • Consult Factory
	Dist Jump	Echo processing module detected actual or impending discontinuity in distance measurement	Transmitter detecting echoes other than valid liquid level and may jump to erroneous level
	Target??	Target distance uncertain due to abnormal shape or location	Consult Factory
	History Defaulted	Information in History file has been reset	Consult Factory

3.4 Agency Approvals

AGENCY	MODEL	PROTECTION METHOD	AREA CLASSIFICATION
United States  APPROVED	R82-52XA-0XX	Intrinsically Safe	Class I, Div. 1; Groups A, B, C, & D T4 @80°C; Type 4X, IP66/67 ① Entity
	R82-51XA-0XX	Non-Incendive ②	Class I, Div. 2; Groups A, B, C, & D Type 4X, IP66/67 ①
Canada  APPROVED	R82-52XA-0XX	Intrinsically Safe	Class I, Div. 1; Groups A, B, C, & D T4 @80°C; Type 4X, IP66/67 ① Entity
	R82-51XA-0XX	Non-Incendive ②	Class I, Div. 2; Groups A, B, C, & D T4 @80°C; Type 4X, IP66/67 ①
ATEX/IEC 	R82-5BXA-0XX	Intrinsically Safe ③④ EN60079-0: 2006/IEC 60079-0: 2007 EN60079-11: 2007/IEC 60079-11: 2006 EN60079-26: 2007 standards applied/ IEC 60079-26: 2006	⊕ II 1G Ex ia IIC T4 @70°C Ambient Temp: -40 to +70 °C Ex ia IIC T4 Ga
BRAZIL  INMETRO/TÜV	R82-5BXA-0XX	Intrinsically Safe ③④ ABNT NBR IEC 60079-0: 2006 ABNT NBR IEC 60079-11: 2009 ABNT NBR IEC 60529: 2005	BR-Ex ia IIC T4, IP66/IP67 ① ABNT NBR IEC 60079-0: 2006 Ambient Temp: -40 to +70 °C AEX-12645-X

- ① Type 4X rating applies to aluminum housing only; IP67 rating applies to Lexan housing only.
- ② For Division 2 the measured media inside the vessel must be non-flammable only. The transmitter must be connected to an inherently limited Class 2 power source (as defined in the NEC Table 11), or as a low energy Class 2 power source (as defined in the CEC Section 16).

Special conditions for safe use (ATEX/IEC Ex i)

- ③ Materials marked as Category 1 equipment and mounted in hazardous areas requiring this Category shall be installed in such a way that, even in the event of rare incidents, the aluminum enclosure cannot be an ignition source due to impact or friction.
- ④ The transmitter shall be installed so that electrostatic discharges on plastic parts are prevented.



These units have been tested to ETSI EN 302 372-1 and ETSI EN 301 489-1 and are in compliance with the RTTE Directive 1999/5/EC. In addition these units were tested to EN 61326 and are in compliance with the EMC Directive 2004/106/EC.

IEC/ATEX Entity Parameters

U _i	28.4 VDC	28 VDC
I _i	94 mA	120 mA
P _i	0.67 w	0.84 w
C _i	5.5 nF	
L _i	370 μH	

SIL

	Model R82	
SIL	1 as 1oo1	
Instrument Type	B	
SFF	89.1%	
PFDavg	3.34E-04	
	FITS	Annual
Fail Dangerous Undetected	68	5.96E-04
Fail Dangerous Detected	388	3.40E-03
Safe	169	1.48E-03

COMMUNICATIONS APPROVALS

Region	Agency	Frequency
US	FCC	26 GHz
Canada	IC	
Europe	RTTE	

Radar level device installed in closed plastic tanks, metallic tanks or reinforced concrete tanks.

3.4.1 Agency (FM/CSA) Drawing and Entity Parameters

HAZARDOUS LOCATIONS

Model R82, Radar Level Transmitter
Intrinsically Safe for CL I, Div. 1 Groups A,B,C,D

ENTITY
 $V_{max} = 28.6V$
 $I_{max} = 140mA$
 $P_{max} = 1.0W$
 $C_i = 5.5nF$
 $L_i = 9.4\mu H$

NON HAZARDOUS LOCATIONS

Limiting Values

$V_{oc} \leq 28.6V$ $C_a \geq 5.5nF$
 $I_{sc} \leq 140mA$ $L_a \geq 9.4\mu H$

The voltage (V_{max}) and current (I_{max}), which the transmitter can receive, must be equal to or greater than the maximum open circuit voltage (V_{oc}) and the maximum short circuit current (I_{sc}) which can be delivered by the source device. In addition, the maximum capacitance (C_i) and inductance (L_i) of the load and the capacitance and inductance of the interconnecting wiring must be equal to or less than the capacitance (C_a) or the inductance (L_a), which can be driven by the source device.

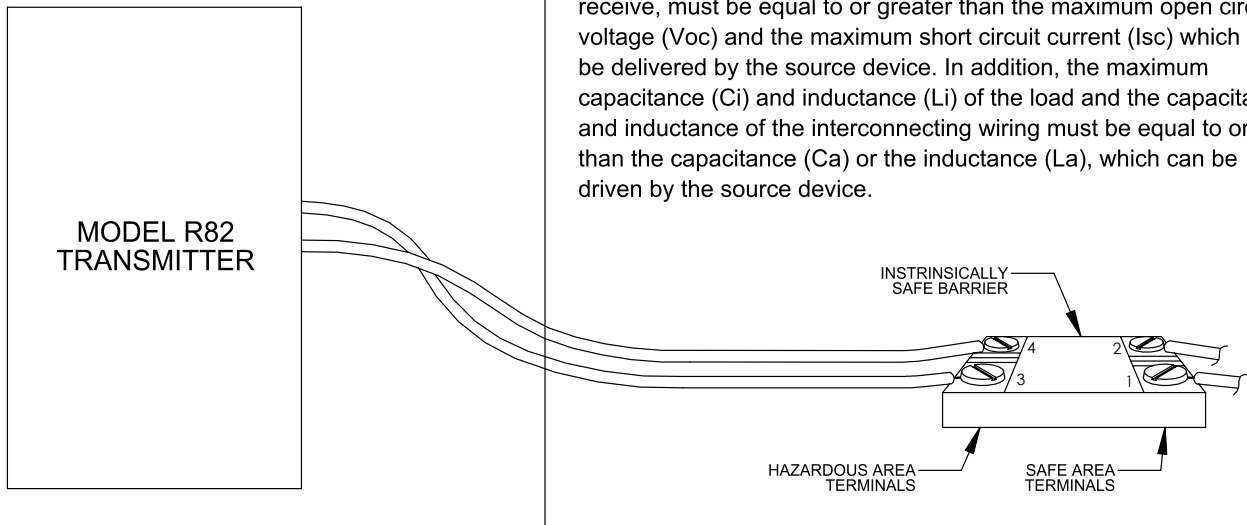

"SEE NOTE 2"

Notes:

1. Manufacturers installation instructions supplied with the protective barrier and the CEC (for Canada) or the NEC and ANSI/ISA RP 12.6 (For US) must be followed when installing the equipment. The Associated Apparatus must be FM Approved.
2. Control equipment connected to protective barriers must not use or generate more than 250 Vdc or Vrms. Resistance between Intrinsically Safe ground and earth ground must be less than 1.0 Ohm.
3. No revisions to this drawing without FM approval.
4. For Canada: Exia Intrinsically Safe / Securitie Intrinseque
5. **Warning - Explosion Hazard** - Substitution of components may impair Intrinsic Safety.
Warning - Explosion Hazard - Do not disconnect equipment unless power has been switch off or the area is known to be non-hazardous.
6. For supply connections, use wire suitable for operating temperature. For 80 °C ambient, use wire with a minimum temperature rating of 85 °C
7. The device can also be installed in Class I, Div. 2 Groups A B C D; Hazardous Locations and does not require connection to a protective barrier when installed per the CEC (for Canada) or the NEC (for US) and when connected to a power source not exceeding 30V. Field wiring must be installed in conduit per the CEC and the NEC. The apparatus must be only connected to an inherently limited power source (Class 2 Power Supply) as defined in the NEC table II.
8. The FM Approved Associated Apparatus must be a linear output device.



705 ENTERPRISE ST., AURORA, IL 60504
PHONE: (630)969-4000

099-5070-001-A SHEET 2 OF 2

Drawing Last Modified: 2018-09-24 11:02:13 AM

3.5 Parts

3.5.1 Replacement Parts

Item	Description		Part Number
①	Electronic Module – 26 GHz	Aluminum Housing	89-9124-001
		Lexan® Housing	89-9124-002
②	O-ring: Aluminum Housing Lexan Housing	Viton	012-2201-237
		Buna N	012-2616-237
③	Housing Cover, Aluminum	GP/IS	036-4410-010
④	Housing Cover, Lexan	GP/IS	003-1226-003

3.5.2 Recommended Spare Parts

Description		Part Number
Electronic Module – 26 GHz	Aluminum Housing	89-9124-001
	Lexan Housing	89-9124-002

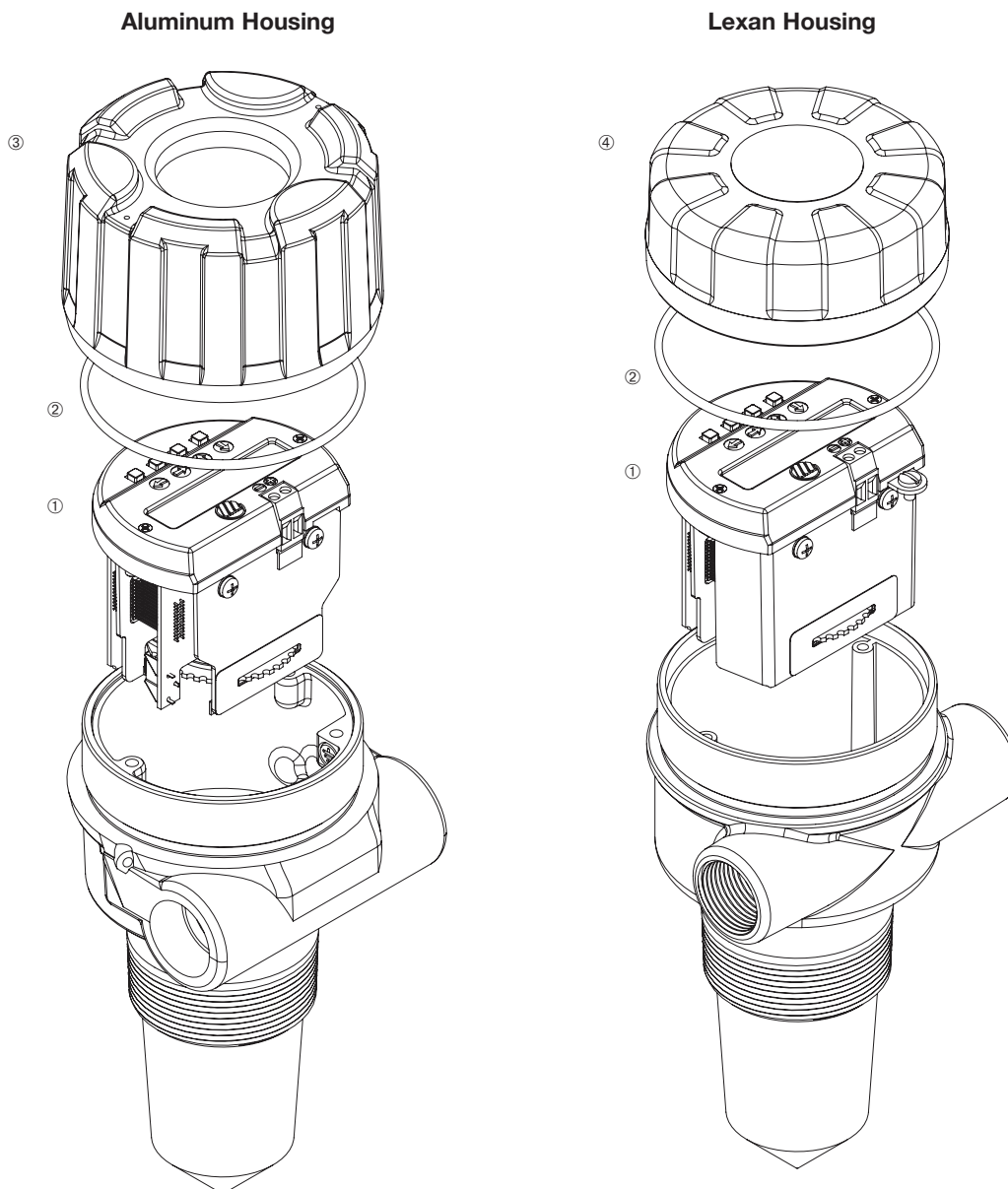

Figure 32

3.6 Specifications

3.6.1 Functional – Transmitter

System Design

Measurement Principle Pulse burst radar @ 26 GHz ①

Input

Measured Variable Level, determined by the time-of-flight of a radar pulse from transmitter to product surface and back

Span 15" to 40 feet (380 mm to 12.2 m) measured from threads

Output

Type Analog 4 to 20 mA with optional HART digital signal

Range Analog 3.8 to 20.5 mA useable (Namur NE43)

Digital 0 to 999" (0 to 9999 cm)

Resolution Analog 0.01 mA

Digital 0.1"

Loop Resistance GP/IS - 400 Ω @ 24 VDC/20 mA, 350 Ω @ 24 VDC/22 mA

Diagnostic Alarm Adjustable 3.6 mA, 22 mA, HOLD

Damping Adjustable 0-45

Output at Antenna < .01 mW (avg), < 2 mW (max)

User Interface

Keypad 4-button menu-driven data entry and system security

Indication 2-line \times 16-character display

Digital Communication HART Version 5 compatible

Power (Measured at instrument terminals)

General Purpose/Intrinsically Safe 16 to 36 VDC

① RTTE: European approval, FCC & IC: North American approval

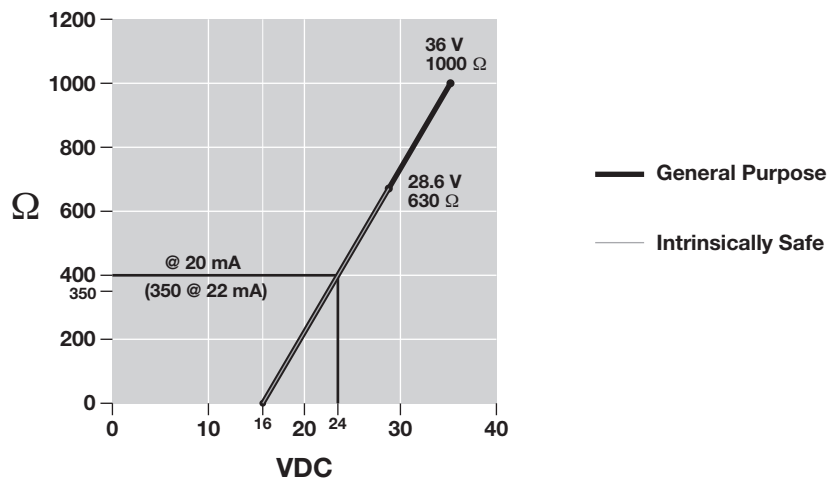

Figure 33

3.6.1 Functional – Transmitter (cont.)

Housing

Material:	Lexan® base and cover	
	Cast aluminum A356T6 (<0.2% copper)	
Cable Entry:	¾" NPT, M20	
Ingress Protection:	Lexan Housing:	NEMA 6P (IP67/68) ②
	Aluminum Housing:	NEMA 4X/6P (IP67/68) ②
Net/Gross Weight:	Short Lexan	1.44 lb (0.65 kg)
	Long Lexan	2.00 lb (0.91 kg)
	Short Aluminum	3.06 lb (1.39 kg)
	Long Aluminum	3.63 lb (1.65 kg)
Overall Dimensions:	Lexan	see drawings on page 58
	Aluminum	see drawings on page 58

Antenna

Encapsulated Horn	Polypropylene, ETFE (optional)	
	-40 to +200F @atmos (-40 to 93C)	
	Vacuum to 200 psig @ 70F (-1 to 13.8 bar) ETFE	
Wetted Surfaces	Polypropylene or ETFE (optional)	

Environment

Operating Temperature	-40 to +175 °F (-40 to +80 °C)	
LCD	-5 to +160 °F (-20 to +70 °C)	
Storage Temperature	-50 to +175 °F (-46 to +80 °C)	
Humidity	0-99%, non-condensing	
Electromagnetic	Meets CE Requirements: EN 50081-2, EN 50082-2	
Surge Protection	Meets CE Requirements: EN 61326 (1000 volts)	
Shock Class	ANSI/ISA-S71.03 Class SA1	
Vibration Class	ANSI/ISA-S71.03 Class VC2	

② Installation for NEMA 6P/IP 68: the transmitter can be installed to allow for temporary submergence to 6.5 ft. (2 m) for 24 hours.

3.6.2 Performance

Reference Conditions	Reflection from ideal reflector at +70 °F (+20 °C)
Linearity	±0.2 inch (5 mm) or 0.05% of tank height (whichever is greater)
Measured Error	±0.2 inch (5 mm) or 0.05% of tank height (whichever is greater) <i>Within 60" (1.5m) of antenna threads, performance will begin degrading, reaching ±0.8" (2 cm) within 15" (38 cm)</i>
Resolution	0.1 inch (2.5 mm)
Repeatability	< 0.1 inch (2.5 mm) or 0.025% of tank height
Response Time	< 1 second
Warm-up Time	30 seconds
Ambient Temp. Effect	±.02% of span per degree C, tank heights > 100" (2.54 m)
Process Dielectric Effect	< 0.3 inch within selected range
Maximum Rate of Change	180 inches (450 cm)/minute
Minimum Dielectric:	1.7

3.6.3 Functional – Encapsulated Horn Antenna

Antenna	Polypropylene	ETFE
Process Connection	2" NPT/BSP hygienic flanges	
Maximum Process Temperature	-40 to +200 °F @ atmos (-40 to +93 °C @ atmos)	
Maximum Process Pressure	Vacuum to 200 psig @ +70 °F (-1 to 13.8 bar @ +20 °C)	
Minimum Dielectric (application dependent)	1.7	

3.6.4 Antenna Pressure / Temperature Ratings

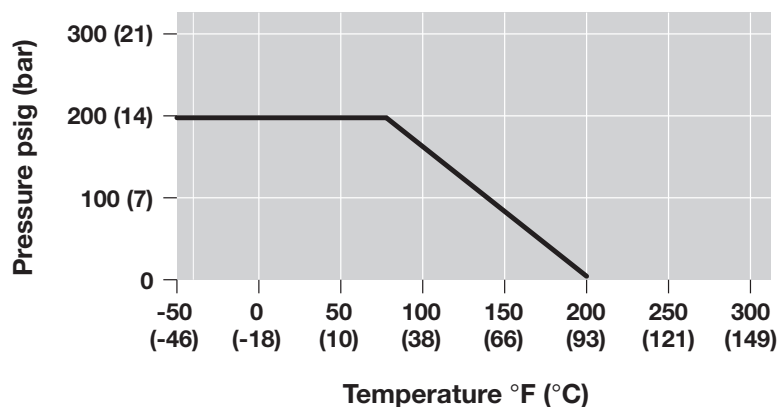

3.6.5 Physical – Inches (mm)

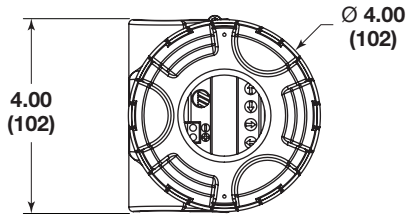

Aluminum Housing
Top View

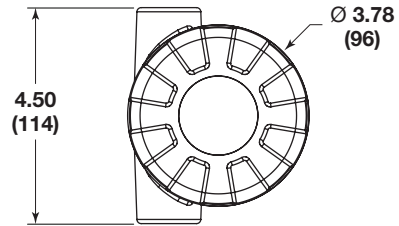

Lexan® Housing
Top View

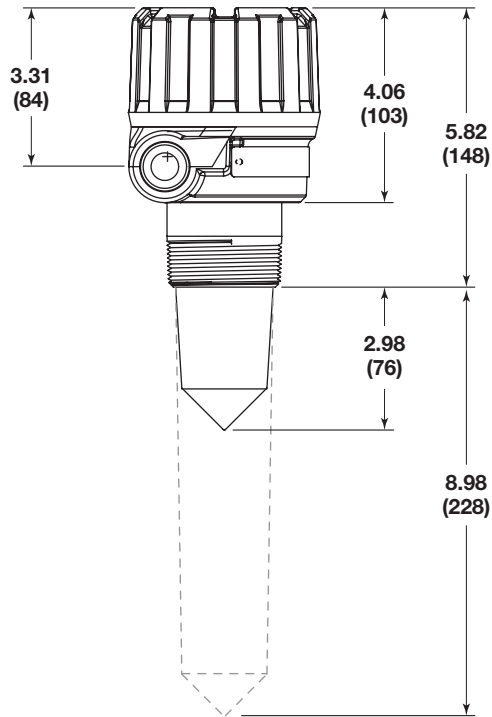

Aluminum Housing
Side View

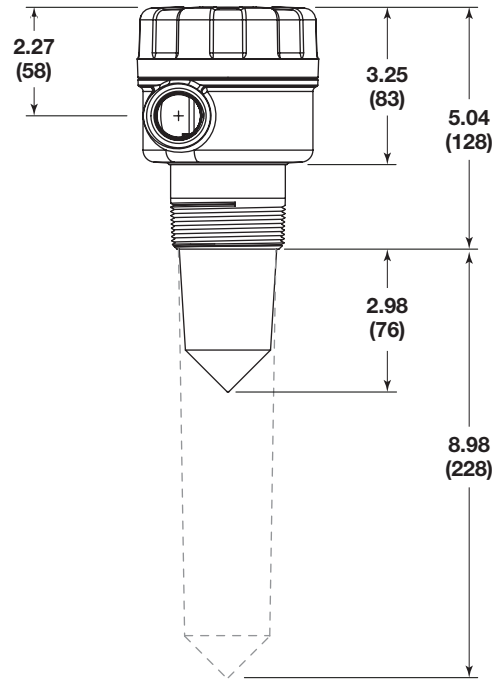

Lexan® Housing
Side View

3.7 Model Numbers

3.7.1 Model R82 Radar Transmitter

BASIC MODEL NUMBER

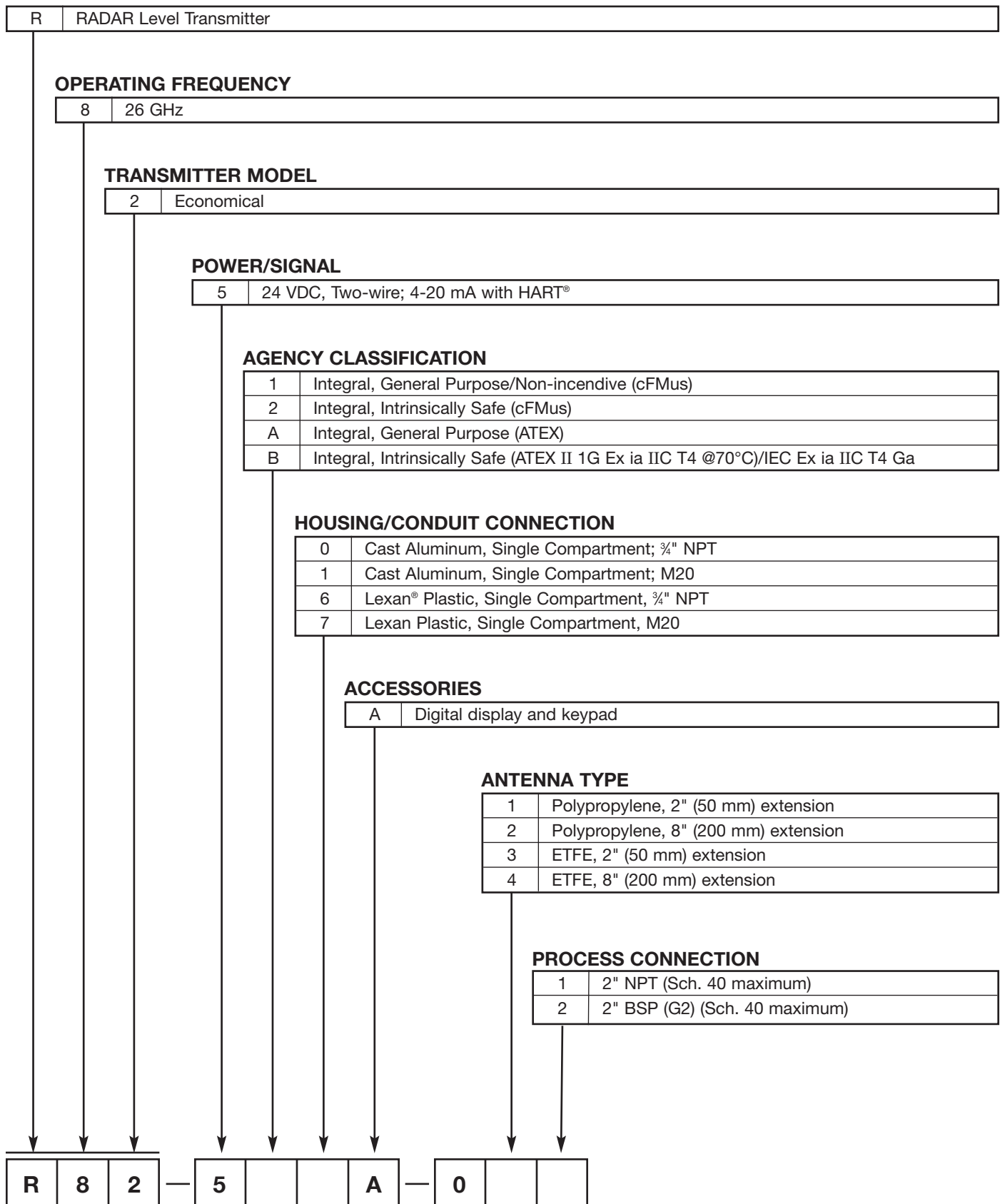

Glossary

Accuracy The closeness of agreement between the result of measurement and the true value of the measure (inaccuracy equals the maximum positive and negative % deviation over the total span).

ANSI American National Standards Institute.

Antenna A mechanical component that serves as an impedance match between the transmission of a signal in a cable (or waveguide) and air.

AntnaMnt *Antenna Mount* The type of process mounting (NPT, BSP or Flange) utilized in the installation. This aids in establishing an exact Sensor Reference Point for Radar propagation and measurement.

AntnaTyp *Antenna Type* A particular antenna configuration or design. Each antenna design has a set of unique performance characteristics.

ATEX *ATmosphere EXplosive* European regulations governing the use in hazardous areas.

BlockDist *Blocking Distance* The area near the antenna where reflections cannot be measured effectively due to antenna ringing and noise.

CE *Conformité Européene* Standards and performance criteria for the new European Union.

CENELEC *Comité Européen de Normalisation Electrotechnique* European organization that sets standards for electrical equipment.

CSA *Canadian Standards Association* Canadian, third party agency that qualifies the safety of electrical equipment.

Damping Factor applied to smooth output variations due to turbulence.

Default Screen The main position of the menu structure that displays the primary measurement values of STATUS, LEVEL, ECHO STRENGTH, % OUTPUT, LOOP CURRENT, LOCAL TAG. The transmitter returns to this position after 5 minutes of inactivity (except Screens 2-6).

Diagnostics Three levels of error messages; Fault, Warning and Information.

Dielectric Constant (ϵ) The electrical permittivity of a material. The units are farad/meter. Typical values: Hydrocarbons 1.9–3, Glycol 32, Water-based media 80. See Technical Handbook 41-600 for complete listing.

Dielectric Rod antenna A non-metallic (TFE and polypropylene typical) transition between the microwave waveguide and air.

Distance The present reading measured from the transmitter's Sensor Reference Point to the material in a vessel; compliment of Level.

DVM/DMM Digital Volt Meter/Digital Multimeter.

Electromagnetic Energy The radiation that travels through space as electric and magnetic fields varying with position and time. Examples in increasing frequency: radio waves, microwave, infrared light, visible light, ultraviolet light, x-rays, gamma waves, and cosmic waves.

EM See Electromagnetic Energy.

EMI *Electromagnetic Interference* Electrical noise caused by electromagnetic fields that may affect electrical circuits, particularly low-power electronic devices.

EN *European Normal* Committee guidelines in EC countries that take precedence over local, country guidelines.

ENV Preliminary EN guidelines, or pre-standards.

Ergonomic A mechanism that considers human capability in its design or function.

ETS *Equivalent Time Sampling* Process that captures high speed electromagnetic events in real time (nanoseconds) and reconstructs them into an equivalent time (milliseconds).

Explosion Proof Enclosure An enclosure designed to withstand an explosion of gas or vapor within it and prevent the explosion from spreading outside the enclosure.

Factory Sealed A third-party-approved Explosion Proof seal installed in the unit during manufacturing. This alleviates the end user from installing an external XP seal adjacent (within 18") to the device.

Fault The highest level in the hierarchy of diagnostics annunciating a defect or failure in circuitry or software that preclude reliable measurement. The current (mA) value unit defaults to 3.6, 22, or Hold and a message is displayed on the rotating screen. Further information can be obtained by viewing the Status or Diagnostic (Factory Menu) screens.

Feedthrough A small, connecting cavity between the main housing compartments, carrying the cable that supplies the operating energy to the measurement circuitry and returns the output value proportional to level. This cavity is potted to maintain the environmental isolation between the two compartments.

Fiducial A reference signal (baseline) to which all measurements are referenced.

FM *Factory Mutual* American, third party agency that qualifies the safety of electrical equipment.

Foam The entraining of air in a liquid. The effect of foam on radar measurement is based on four factors; 1.) dielectric of the liquid from which the foam has developed, 2.) density of the foam (bubble size), 3.) amount of foam above the liquid and, to a lesser extent, 4.) wall thickness of the bubbles.

Four Wire An electronic instrument design that uses one set of wires to supply power (120/240 VAC, 24 VDC) and another set to carry the process measurement signal (4–20 mA). Also called Line Powered.

FSK *Frequency Shift Keying* See HART.

Gain Amplification adjustment to attain optimum performance in various product dielectric ranges. (Factory setting).

Ground An electrical connection to the Earth's potential that is used as a reference for the system and electrical safety.

Grounded A state where no electrical potential exists between the ground (green) connection on the transmitter and the Earth or system ground.

Guided Wave Radar See TDR.

HART *Highway Addressable Remote Transducer* Protocol that uses the Bell 202 frequency shift keying (FSK) method to superimpose low level frequencies (1200/2000 Hz) on top of the standard 4–20 mA loop to provide digital communication.

HART ID See Poll Address.

Hazardous Area An area where flammable gases or vapors are or may be present in the air in quantities sufficient to produce explosive or ignitable mixtures.

Horn Antenna A metallic, cone transition between the microwave waveguide and air.

IEC *International Electrotechnical Commission* Organization that sets international standards for electrical devices.

Increased Safety Designs and procedures that minimize sparks, arcs, and excessive temperatures in hazardous areas. Defined by the IEC as Zone 1 environments (Ex e).

Information (message) The lowest level in the hierarchy of diagnostic conditions providing operational factors that are not critical to measurement. Further information can be obtained by viewing the Status or Diagnostic (Factory Menu) screens.

Intrinsically Safe Ground A very low resistance connecting to a ground, in accordance with the National Electrical Code (NEC, ANSI/NFPA 70 for FMRC), the Canadian Electrical Code (CEC for CSA), or the local inspector.

Intrinsic Safety A design or installation approach that limits the amount of energy that enters a hazardous area to eliminate the potential of creating an ignition source.

Level The present reading of the height of material in a vessel; compliment of Distance.

Level Offset *Level Offset* The distance above the tank bottom where radar level measurement is impossible due to heating coils, baffles, angled or curved tank bottoms, etc. The mA output will never read lower than the Level Offset value.

Linearity The worst case error calculated as a deviation from a perfect straight line drawn between two calibration points.

Line Powered See Four Wire.

LOE *Loss of Echo* Condition where a level measurement is impossible due to the absence of valid reflections from the liquid surface.

LOE Delay *Loss of Echo Delay* The amount of time the transmitter spends looking for a valid Level signal before going into Loss of Echo Fault. The last valid Level reading is held during this search.

LOE Fault *Loss of Echo Fault* The mA value to which the output is driven after the Loss of Echo Delay times out; choices are 3.6mA, 22mA and HOLD.

Loop The present reading of the 4–20 mA current output.

Loop Powered See Two Wire.

Loop Tst *Loop Test* Built-in system capability to test/calibrate a loop (or separate loop device) by driving the transmitter output to a particular value.

Low Voltage Directive A European Community requirement for electrical safety and related issues of devices using 50-1000 VDC or 75–1500 VAC.

Measured Value The typical level measurement values used to track the level of a process: Level, % Output, and Loop.

Media The liquid material being measured by the level transmitter.

Multidrop The ability to install, wire, or communicate with multiple devices over one cable. Each device is given a unique address and ID.

Non-hazardous Area An area where no volatile mixtures of vapors/gas and oxygen will be found at any time. Also called General Purpose Area.

Non-Incendive A circuit in which any arc or thermal effect produced, under intended operating conditions of the equipment or due to opening, shorting, or grounding of field wiring, is incapable, under specific test conditions, of igniting the flammable gas, vapor, or dust-air mixture.

Password A numerical value between 0 and 255 that protects stored configuration data from unauthorized manipulation.

Percent (%) Output The present reading as a fraction of the 16 mA scale (4–20 mA).

Poll Address (HART ID) A number between 1 and 15 which sets an address or location of a device in a multi-drop loop. Poll address for single device configuration is 0.

Qual *Quality* A relative value (0–99) that shows the strength and usefulness for a given reflected signal.

QuickStart The essential information needed for the R82 radar transmitter and antenna to be installed, wired, and calibrated.

Radar (Radio Detection And Ranging) Uses EM energy and high speed timing circuits to determine distance. Original Radar devices used energy in the radio frequency range (MHz), many current devices use much higher frequencies (GHz).

Range The distance over which the transmitter scans for valid return signals.

RateChng *Rate of Change* The maximum velocity of vertical movement of a liquid's surface.

Relative Dielectric (ϵ_r) A unitless number that indicates the relative permittivity of a material.

Repeatability The maximum error between two or more output readings of the same process condition.

RFI *Radio Frequency Interference* Electrical noise that can have an adverse affect on electrical circuits, particularly low-power devices.

Safety Zone A user-defined area just below the Blocking Distance where level measurement still has a high degree of reliability. Radar can develop ambiguous readings when the level reaches the region of the antenna. An alarm can be annunciated in this area for critical applications where reliable measurement is a necessity for safety reasons.

Safety Zone Height The height of the region below the Blocking Distance where an alarm will be annunciated upon detection of liquid.

Safety Zone Fault An optional condition added, when necessary, to ensure safe, reliable high-level readings in critical applications. Choices are 3.6 mA, 22 mA, Latch 3.6 or Latch 22. If Latch 3.6 or Latch 22 are chosen, the loop current will remain in alarm until it is cleared in SZ Latch menu screen.

Safety Zone Alarm Reset Use screen for clearing a Latched Alarm set in **Safety Zone Fault** (above)

SnsrOfst *Sensor Offset* The distance (+ or -) between the customer's 100% reference point (tank top) and the Sensor reference point (bottom of NPT thread, top of BSP thread or face of flange).

Span The difference between the upper and lower limits of the range.

Specific Gravity (SG) The ratio of the density of a material to the density of water at the same conditions.

Sensitivity The amount of amplification applied to the Level signal; a higher value aids in measuring low dielectric media; a lower number assists in ignoring nearby objects.

Status The current state of the transmitter's diagnostics; screen updates every 10 seconds.

Targets Objects in the vessel that create reflections of the radar signal (microwave energy).

Targ Rej *Target Rejection* The ability to ignore reflections from objects in the vessel that are not the liquid level, i.e., false targets (e.g. pipes, ladders, baffles).

Tank Ht *Tank Height* The tank measurement between the 0% (tank bottom) and 100% (tank top).

Tank Top The 100% point in a vessel. Also considered for the type of tank top; e.g. flat, dome, etc., which affects the development of multiple echoes during high level conditions. Multiple echoes can appear as an invalid Level signal.

TDR (Time Domain Reflectometry) Uses a waveguide to carry EM energy to and from the surface of the media to measure distance; similar to conventional through-air Radar but much more efficient. Also called Guided Wave Radar.

Trim 4/Trim 20 Built-in system capability to fine tune the 4 mA and 20 mA points so the transmitter output corresponds exactly to user's meter, DCS input, etc.

Trim Lvl *Trim Level* An offset parameter used to account for various deviations in measurement. It is an offset value that can force the transmitter to read the exact level reading.

Turbulnc *Turbulence* Agitation, or disturbance, of the liquid level surface; greater the agitation, greater the scattering of the radar signal (microwave energy).

Two Wire An electrical instrument design that uses one set of wires to provide both the supply power and process measurement signal. The process measurement is achieved by varying the current of the loop. Also called Loop Powered.

Units The engineering units used to measure level in the system. The choices are in (inches) and cm (centimeters).

Warning (message) The second level in the hierarchy of Diagnostics annunciating conditions that are not fatal but may affect measurement. A message will occur on the main (rotating) screen when a Warning is detected but will not affect output current. Further information can be obtained by viewing the Status or Diagnostic screens.



R82 Radar Transmitter Configuration Data Sheet

Company _____

Date _____

Copy blank page and store calibration data for future reference and troubleshooting.

Item	Value	Value	History	Device Status	Run Time
				Occurred	Duration
Vessel Name			Event 19		
Vessel #			18		
Media			17		
Media Dielectric			16		
Tag #			15		
Level			14		
Measurement Type			13		
Units			12		
Sensor Offset			11		
Tank Top			10		
Tank Height			9		
Blocking Distance			8		
Level Offset			7		
Dielectric			6		
Turbulence			5		
Foam			4		
Rate of Change			3		
Echo List Mode			2		
Echoes #1			1		
#2					
#3					
#4					
#5					
			Item (factory defaults)	Value	Value
Echo Rejection			Run Time		
Loop Control			System Code		
4 mA point			Electronics Temp		
20 mA point			Max. Temperature		
Damping			Min. Temperature		
System Fault			VDC Check Midpoint		
LOE Fault			Antenna Mount		
LOE Delay			Target Algorithm		
SZ Fault			TVG Minimum		
SZ Height			TVG Maximum		
SZ Alarm Reset			Peak Detect Reference		
Trim Level			Peak Detect Threshold		
Pipe I.D.			Min Thresold		
Trim 4 mA			# Run Average		
Trim 20 mA			# Adapt Average		
Test 4-20 Loop			Scatter High Limit		
HART Poll Address			Rate High Limit		
New Password			Scatter Rate		
Language			Lvl ROC per Min		
Serial Number			Max ROC per Min		
Model R82 VerX.XXX			Max Distance Jump		
			Boundary State		
			Empty State Delay		
			NSP Value		
			HART Device ID		

Service Policy

Owners of MAGNETROL may request the return of a control or any part of a control for complete rebuilding or replacement. They will be rebuilt or replaced promptly. Controls returned under our service policy must be returned by Prepaid transportation. MAGNETROL will repair or replace the control at no cost to the purchaser (or owner) other than transportation if:

1. Returned within the warranty period; and
2. The factory inspection finds the cause of the claim to be covered under the warranty.

If the trouble is the result of conditions beyond our control; or, is NOT covered by the warranty, there will be charges for labor and the parts required to rebuild or replace the equipment.

In some cases it may be expedient to ship replacement parts; or, in extreme cases a complete new control, to replace the original equipment before it is returned. If this is desired, notify the factory of both the model and serial numbers of the control to be replaced. In such cases, credit for the materials returned will be determined on the basis of the applicability of our warranty.

No claims for misapplication, labor, direct or consequential damage will be allowed.

Return Material Procedure

So that we may efficiently process any materials that are returned, it is essential that a "Return Material Authorization" (RMA) number be obtained from the factory, prior to the material's return. This is available through your MAGNETROL local representative or by contacting the factory. Please supply the following information:

1. Company Name
2. Description of Material
3. Serial Number
4. Reason for Return
5. Application

Any unit that was used in a process must be properly cleaned in accordance with OSHA standards, before it is returned to the factory.

A Material Safety Data Sheet (MSDS) must accompany material that was used in any media.

All shipments returned to the factory must be by prepaid transportation.

All replacements will be shipped F.O.B. factory.

Model R82 Radar transmitters protected by U.S. Patent No. US 7,271,646 (may depend on model).



705 Enterprise Street • Aurora, Illinois 60504-8149 • 630.969.4000
info@magnetrol.com • magnetrol.com

Copyright © 2019 Magnetrol International, Incorporated

Viton is a registered trademark of DuPont Performance Elastomers
HART is a registered trademark of the HART Communication Foundation
PACTware is a trademark of PACTware Consortium
CSA logotype is a registered trademark of Canadian Standards Association
Tri-Clover is a registered trademark of Tri-Clover, Inc.
Lexan is a registered trademark of General Electric

BULLETIN: 58-610.10
EFFECTIVE: June 2019
SUPERSEDES: September 2016