

Installation & Maintenance Instructions

MAGNETROL PULSAR

MODEL R96 RADAR LEVEL TRANSMITTER

Registered Address

ABLE Instruments & Controls Ltd
Cutbush Park, Danehill, Lower Earley,
Reading, Berkshire, RG6 4UT. UK.

Reading

Tel: +44 (0)118 9311188 | Email: info@able.co.uk

Aberdeen

Tel: +44 (0)1224 725999 | Email: ab@able.co.uk

Web

able.co.uk

E-commerce

247able.com



Registered in England No. 01851002. VAT No. GB 417 2481 61

PULSAR® R96 RADAR

Pulsar® Model R96 FOUNDATION fieldbus™ Operating Manual

Software Version 1.x

*High Performance
Pulse Burst Radar
Level Transmitter*



Read this Manual Before Installing

This manual provides information on the Pulsar® Model R96 Pulse Burst Radar transmitter with FOUNDATION fieldbus™ Output and should be used in conjunction with PULSAR I&O manual 58-602. It is important that all instructions are read and followed carefully.

Safety Messages

The PULSAR system is designed for use in Category II, Pollution Degree 2 installations. Follow all standard industry procedures for servicing electrical and computer equipment when working with or around high voltage. Always shut off the power supply before touching any components. Although high voltage is not present in this system, it may be present in other systems.

Electrical components are sensitive to electrostatic discharge. To prevent equipment damage, observe safety procedures when working with electrostatic sensitive components.

This device complies with Part 15 of the FCC rules. Operation is subject to the following two conditions: (1) This device may not cause harmful interference, and (2) This device must accept any interference received, including interference that may cause undesired operation.

WARNING! Explosion hazard. Do not connect or disconnect designs rated Explosion proof or Non-incendive unless power has been switched off and/or the area is known to be non-hazardous

Low Voltage Directive

For use in Installations Category II, Pollution Degree 2. If equipment is used in a manner not specified by the manufacturer, protection provided by equipment may be impaired.

Notice of Copyright and Limitations

Copyright © 2019 Magnetrol International

All rights reserved

MAGNETROL & MAGNETROL logotype, and PULSAR are registered trademarks of Magnetrol International.

Performance specifications are effective with date of issue and are subject to change without notice.

MAGNETROL reserves the right to make changes to the product described in this manual at any time without notice. MAGNETROL makes no warranty with respect to the accuracy of the information in this manual.

Warranty

All MAGNETROL electronic level and flow controls are warranted free of defects in materials or workmanship for eighteen months from the date of original factory shipment. If returned within the warranty period; and, upon factory inspection of the control, the cause of the claim is determined to be covered under the warranty; then, Magnetrol will repair or replace the control at no cost to the purchaser (or owner) other than transportation.

MAGNETROL shall not be liable for misapplication, labor claims, direct or consequential damage or expense arising from the installation or use of equipment. There are no other warranties expressed or implied, except special written warranties covering some Magnetrol products.

Quality assurance

The quality assurance system in place at MAGNETROL guarantees the highest level of quality throughout the company. Magnetrol is committed to providing full customer satisfaction both in quality products and quality service.

The MAGNETROL quality assurance system is registered to ISO 9001 affirming its commitment to known international quality standards providing the strongest assurance of product/service quality available.



Pulsar® Model R96 Pulse Burst Radar Transmitter with FOUNDATION fieldbus™ Output

Table of Contents

1.0 FOUNDATION fieldbus™	
1.1 Overview.....	4
1.2 Device Description (DD).....	5
1.2.1 FOUNDATION fieldbus™ DD Revision Table.....	5
1.3 Link Active Scheduler (LAS).....	5
1.4 Intrinsic Safety.....	6
2.0 Standard Function Blocks	
2.1 Overview.....	7
2.1.1 Universal Fieldbus Block Parameters.....	8
2.2 Resource Block (RB).....	9
2.2.1 RB Parameters.....	9
2.2.2 Additional Resource Block Parameters.....	11
2.3 Transducer Block (TB).....	13
2.3.1 TB Parameters.....	14
2.3.2 Password Protection.....	14
2.3.3 Model R96 FF Configuration Parameters.....	14
2.3.4 Model R96 FF Device-Specific Configuration Parameters.....	15
2.4 Analog Input Block (AI).....	15
2.4.1 AI Block Parameters.....	15
2.4.2 AI Block Diagnostics.....	18
2.4.3 Local Display of AI Block.....	18
2.4.3.1 AI Out Display Screens.....	19
2.4.4 AI Block Configuration.....	20
2.4.5 Simulation Feature.....	21
2.5 PID Block.....	21
2.5.1 PID Block Parameters.....	21
3.0 Advanced Function Blocks	
3.1 Arithmetic Block (AR).....	24
3.2 Input Selector Block (ISEL).....	27
3.3 Signal Characterizer Block (SC).....	28
4.0 Model R96 Transmitter Configuration	
4.1 Configuration Information.....	30
4.2 Menu Transversal and Data Entry.....	31
4.2.1 Navigating the Menu.....	31
4.2.2 Data Selection.....	31
4.2.3 Entering Numeric Data Using Digit Entry.....	32
4.2.4 Entering Numerical Data Using Increment/Decrement.....	32
4.2.5 Enter Character Data.....	33
4.3 Password Protection.....	33
4.4 Model R96 Menu: Step-By-Step Procedure.....	34
4.5 Model R96 Configuration Menu: Device Setup.....	36
5.0 Troubleshooting and Diagnostics	
5.1 Diagnostic Parameters.....	40
5.1.1 Diagnostics (Namur NE 107).....	41
5.1.2 Diagnostic Indication Simulation.....	43
5.1.3 Diagnostic Indicator Table.....	43
5.1.4 Diagnostic Help.....	46
5.2 Diagnostic Parameters.....	47
5.3 FOUNDATION fieldbus Segment Checklist.....	49
6.0 Reference Information	
6.1 Agency Approvals.....	50
6.1.1 Agency Approvals Chart.....	50
6.1.2 Agency Specifications.....	51
Explosion Proof Installation.....	51
6.1.3 Agency Installation Drawing.....	51
6.2 Specifications.....	52
6.2.1 Functional - Transmitter.....	52
6.3 Model Number	
6.3.1 Transmitter.....	53
6.3.2 Antenna — Dielectric Rod.....	54
6.3.3 Antenna — Horn.....	55
6.4 Replacement Parts	
6.4.1 Replacement Parts.....	56
Appendix A.....	57

1.0 FOUNDATION fieldbus™

1.1 Overview

FOUNDATION fieldbus™ is a digital communications system that serially interconnects devices in the field. A Fieldbus system is similar to a Distributed Control System (DCS) with two exceptions:

- Although a FOUNDATION fieldbus™ system can use the same physical wiring as 4–20 mA device, Fieldbus devices are not connected point to point, but rather are multidropped and wired in parallel on a single pair of wires (referred to as a segment).
- FOUNDATION fieldbus™ is a system that allows the user to distribute control across a network. Fieldbus devices are smart and can actually maintain control over the system.

Unlike 4–20 mA analog installations in which the two wires carry a single variable (the varying 4–20 mA current), a digital communications scheme such as FOUNDATION fieldbus™ considers the two wires as a network. The network can carry many process variables as well as other information. The PULSAR Model R96 FF transmitter is a FOUNDATION fieldbus™ registered device that communicates with the H1 FOUNDATION fieldbus™ protocol operating at 31.25 kbits/sec. The H1 physical layer is an approved IEC 61158 standard.

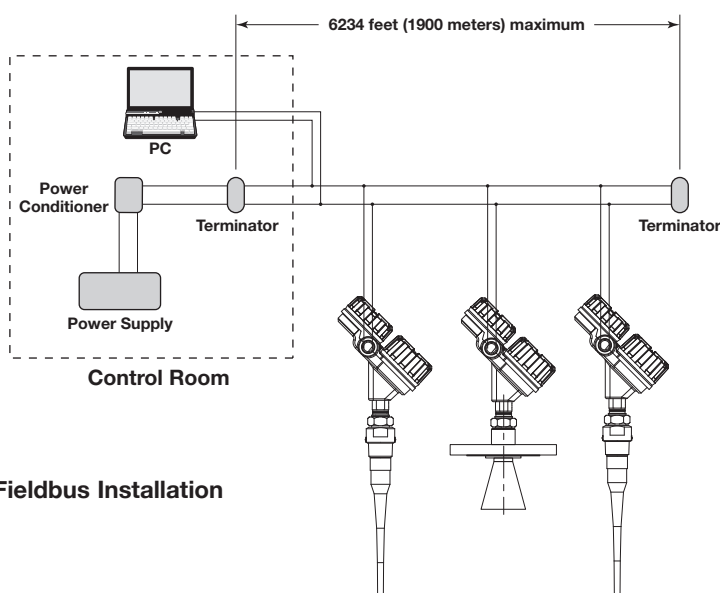

Typical Fieldbus Installation

Details regarding cable specifications, grounding, termination, and other physical layer network information can be found in IEC 61158 or the wiring installation application guide AG-140 at www.fieldbus.org.

1.2 Device Description (DD)

An important requirement of Fieldbus devices is the concept of interoperability, defined as “the ability to operate multiple devices in the same system, regardless of manufacturer, without loss of functionality.”

Device Description (DD) technology is used to achieve this interoperability. The DD provides extended descriptions for each object and provides pertinent information needed by the host system. DDs are similar to the drivers that your personal computer (PC) uses to operate peripheral devices connected to it. Any Fieldbus host system can operate with a device if it has the proper DD and Common File Format (CFF) for that device.

The most recent DD and CFF files can be found on the FOUNDATION fieldbus™ web site at www.fieldbus.org.

NOTE: Consult your host system vendor for any host-specific files that may be needed.

1.2.1 FOUNDATION fieldbus™ DD Revision Table

FOUNDATION fieldbus™ Version	FOUNDATION fieldbus™ Release Date	Compatible with Model R96 Software
Dev V1 DD V1	November 2015	Version 1.0a or later

1.3 Link Active Scheduler (LAS)

The default operating class of the PULSAR Model R96 FF with FOUNDATION fieldbus™ is a Basic device. However, it is capable of being configured as a Link Active Scheduler (LAS).

The LAS controls all communication on a FOUNDATION fieldbus™ segment. It maintains the “Live List” of all devices on a segment and coordinates both the cyclic and acyclic timing.

The primary LAS is usually maintained in the host system, but in the event of a failure, all associated control can be transferred to a backup LAS in a field device such as the PULSAR Model R96 FF transmitter.

NOTES:

- 1) The PULSAR Model R96 is normally shipped from the factory with Device Class set to Basic.
- 2) The operating class can be changed from Basic to LAS using a FOUNDATION fieldbus™ configuration tool.

1.4 Intrinsic Safety

The H1 physical layer supports Intrinsic Safety (IS) applications with bus-powered devices. To accomplish this, an Intrinsically Safe barrier or galvanic isolator is placed between the power supply in the safe area and the device in the hazardous area.

H1 also supports the Fieldbus Intrinsically Safe Concept (FISCO) model which allows more field devices in a network. The FISCO model considers the capacitance and inductance of the wiring to be distributed along its entire length. Therefore, the stored energy during a fault will be less and more devices are permitted on a pair of wires. Instead of the conservative entity model, which only allows about 90 mA of current, the FISCO model allows a maximum of 110 mA for Class II C installations and 240 mA for Class II B installations.

FISCO certifying agencies have limited the maximum segment length to 1000 meters because the FISCO model does not rely on standardized ignition curves.

The PULSAR Model R96 FF is available with entity IS, FISCO IS, FNICO non-incendive, or explosion proof approvals.

2.0 Standard Function Blocks

2.1 Overview

The function of a FOUNDATION fieldbus™ device is determined by the arrangement of a system of blocks defined by the Fieldbus foundation. The types of blocks used in a typical User Application are described as either Standard or Advanced.

Function Blocks are built into the FOUNDATION fieldbus™ devices as needed to provide the desired control system behavior. The input and output parameters of function blocks can be linked over the Fieldbus and there can be numerous function blocks in a single User Application.

The PULSAR Model R96 FF is a Pulse Burst Radar level transmitter with the following standard FOUNDATION fieldbus™ Function Blocks:

- One (1) Resource Block (RB)
- Two (2) Custom Transducer Blocks (TB)
- Six (6) Analog Input Function Blocks (AI)
- Two (2) PID Blocks (PID)

With Advanced Function Blocks:

- One (1) Arithmetic Block (AR)
- One (1) Input Selector Block (IS)
- One (1) Signal Characterizer Block (SC)

The idea of Function Blocks, which a user can customize for a particular application, is a key concept of Fieldbus topology. Function Blocks consist of an algorithm, inputs and outputs, and a user-defined Block Tag.

The Transducer Block (TB) output is available to the network through the Analog Input (AI) blocks. Refer to Section 2.3 for additional information on the Transducer Blocks.

The AI blocks take the TB values and make them available as an analog value to other function blocks. The AI blocks have scaling conversion, filtering, and alarm functions. Refer to Section 2.4 for additional information on the Analog Input Blocks.

As shown in the diagram at left, the end user typically configures the Process Variable value as an Analog Input to their fieldbus network.

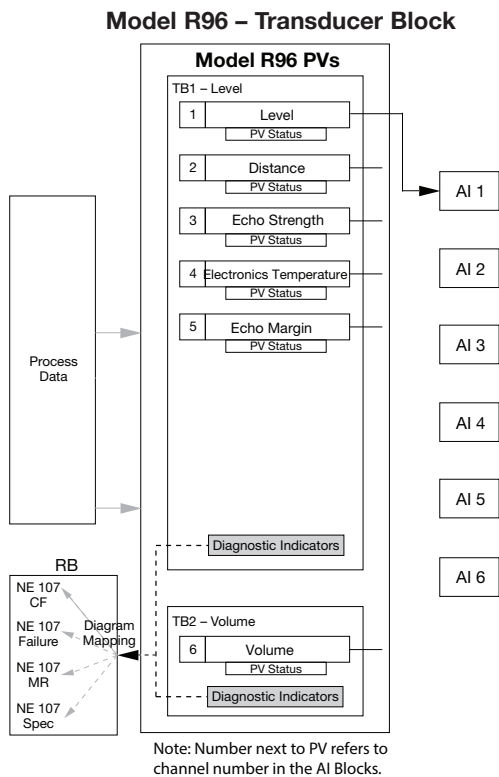

2.1.1 Universal fieldbus Block Parameters

The following are general descriptions of the parameters common to all function blocks. Additional information for a given parameter may be described later in a section that describes the specific block.

ST_REV: a read only parameter that gives the revision level of the static data associated with the block. This parameter will be incremented each time a static parameter attribute value is written and is a vehicle for tracking changes in static parameter attributes.

TAG_DESC: a user assigned parameter that describes the intended application of any given block.

STRATEGY: a user assigned parameter that identifies groupings of blocks associated with a given network connection or control scheme.

ALERT_KEY: a user assigned parameter which may be used in sorting alarms or events generated by a block.

MODE_BLK: a structured parameter composed of the actual mode, the target mode, the permitted mode(s), and the normal mode of operation of a block.

- Target: The mode to “go to”
- Actual: The mode the “block is currently in”
- Permitted: Allowed modes that target may take on
- Normal: Most common mode for target

NOTES:

- 1) It may be required to change the MODE_BLK target parameter to OOS (out of service) to change configuration parameters in that specific function block. (When in OOS, the normal algorithm is no longer executed and any outstanding alarms are cleared.)
- 2) All blocks must be in an operating mode for the device to operate. This requires the Resource Block and the Transducer Block to be in “AUTO” before the specific function block can be placed in a mode other than OOS (out of service).

BLOCK_ERR: a parameter that reflects the error status of hardware or software components associated with, and directly affecting, the correct operation of a block.

NOTE: A BLOCK_ERR of “Simulation Active” in the Resource Block does not mean simulation is active—it merely indicates that the simulation (hardware) enabling jumper is present. (See page 21 and refer to Section 2.4.5 for additional information).

2.2 Resource Block

The RESOURCE BLOCK describes the characteristics of the FOUNDATION fieldbus™ device such as the device name, manufacturer, and serial number. As it only contains data specific to the PULSAR Model R96 FF transmitter, it has no control function.

2.2.1 Resource Block Parameters

MODE_BLK: Must be in AUTO in order for the remaining function blocks in the transmitter to operate.

NOTE: A Resource Block in “out of service” mode will stop all function block execution in the transmitter.

RS_STATE: Identifies the state of the RESOURCE block state machine. Under normal operating conditions, it should be “On-Line.”

DD_RESOURCE: A string identifying the tag of the resource that contains the Device Description for this device.

MANUFAC_ID: Contains Magnetrol International’s FOUNDATION fieldbus™ manufacturer’s ID number, which is 0x000156.

DEV_TYPE: The model number of the PULSAR Model R96 FF transmitter (0x0007). It is used by the Host System and other fieldbus interface devices to locate the Device Descriptor (DD) file.

DEV_REV: Contains the device revision of the PULSAR Model R96 FF transmitter and is used by the Host System and other fieldbus interface devices to correctly select the associated DD.

DD_REV: Contains the revision of the DD associated with the device revision of the PULSAR Model R96 FF transmitter. It is used by the Host System and other Fieldbus interface devices to correctly select the associated DD.

GRANT_DENY: Options for controlling access of host computer and local control panels to operating, tuning and alarm parameters of the block.

HARD_TYPES: The types of hardware available as channel numbers.

RESTART: Default and Processor are the available selections. Default will reset the Model R96 to the default function block configuration.

NOTE: As RESTART DEFAULT will set most function block configuration parameters to their default values. Devices need to be reconfigured following activation of this function.

FEATURES: A list of the features available in the transmitter, such as Reports and Soft Write Lock.

FEATURES_SEL: Allows the user to turn Features on or off.

CYCLE_TYPE: Identifies the block execution methods that are available.

CYCLE_SEL: Allows the user to select the block execution method.

MIN_CYCLE_T: The time duration of the shortest cycle interval. It puts a lower limit on the scheduling of the resource.

MEMORY_SIZE: Available configuration memory in the empty resource.

NV_CYCLE_T: The minimum time interval between copies of non-volatile (NV) parameters to NV memory. NV memory is only updated if there has been a significant change in the dynamic value and the last value saved will be available for the restart procedure.

NOTE: After completing a download, allow several seconds before removing power from the PULSAR Model R96 FF transmitter to ensure that all data has been saved.

FREE_SPACE: Shows the amount of available memory for further configuration. The value is zero percent in a preconfigured device.

FREE_TIME: The amount of the block processing time that is free to process additional blocks.

SHED_RCAS: The time duration at which to give up computer writes to function block RCas locations.

SHED_ROUT: The time duration at which to give up computer writes to function block ROut locations.

FAULT_STATE, SET_FSTATE, CLR_FSTATE: These only apply to output function blocks. (The Model R96 FF has no output function blocks).

MAX_NOTIFY: The maximum number of alert reports that the transmitter can send without getting a confirmation.

LIM_NOTIFY: the maximum numbers of unconfirmed alert notify messages allowed. No alerts are reported if set to zero.

CONFIRM_TIME: the time that the transmitter will wait for confirmation of receipt of a report before trying again. Retry will not occur if CONFIRM_TIME = 0.

WRITE_LOCK: When set to LOCKED, will prevent any external change to the static or non-volatile data base in the Function Block Application of the transmitter. Block connections and calculation results will proceed normally, but the configuration will be locked.

UPDATE_EVT (Update Event): Is an alert generated by a write to the static data in the block.

BLOCK_ALM (Block Alarm): Is used for configuration, hardware, connection, or system problems in the block. The cause of any specific alert is entered in the subcode field.

ALARM_SUM (Alarm Summary): Contains the current alert status, the unacknowledged states, the unreported states, and the disabled states of the alarms associated with the block.

ACK_OPTION (Acknowledge Option): Selects whether alarms associated with the block will be automatically acknowledged.

WRITE_PRI (Write Priority): The priority of the alarm generated by clearing the write lock.

WRITE_ALM (Write Alarm): The alert generated if the write lock parameter is cleared.

ITK_VER (ITK Version): Contains the version of the Interoperability Test Kit (ITK) used by the Fieldbus Foundation during their interoperability testing.

COMPATIBILITY_REV: This parameter is intended to assist users and host system in device replacement scenarios. It is a read-only parameter and the value of the COMPATIBILITY_REV is defined by the device developer and manufacturer. In such device replacement scenario the DEV_REV value of the replaced device is equal or greater than the COMPATIBILITY_REV value of the new device.

2.2.2 Additional Resource Block Parameters

Additional parameters are available within the resource block for use with NE-107 to aid in communicating device conditions to the user.

FD_VER: Major version of the Field Diagnostic specification to which this device conforms.

FD_FAIL_ACTIVE: For error conditions that have been selected for the FAIL alarm category, this parameter reflects those that have been detected as active.

FD_OFFSPEC_ACTIVE: For error conditions that have been selected for the OFFSPEC alarm category, this parameter reflects those that have been detected as active.

FD_MAINT_ACTIVE: For error conditions that have been selected for the MAINT alarm category, this parameter reflects those that have been detected as active.

FD_CHECK_ACTIVE: For error conditions that have been selected for the CHECK alarm category, this parameter reflects those that have been detected as active.

FD_FAIL_MAP: Maps conditions to be detected as active for the FAIL alarm category.

FD_OFFSPEC_MAP: Maps conditions to be detected as active for the OFFSPEC alarm category.

FD_MAINT_MAP: Maps conditions to be detected as active for the MAINT alarm category.

FD_CHECK_MAP: Maps conditions to be detected as active for the CHECK alarm category.

FD_FAIL_MASK: Used to suppress an alarm from being broadcast for single or multiple conditions that are active in the FAIL alarm category.

FD_OFFSPEC_MASK: Used to suppress an alarm from being broadcast for single or multiple conditions that are active in the OFFSPEC alarm category.

FD_MAINT_MASK: Used to suppress an alarm from being broadcast for single or multiple conditions that are active in the MAINT alarm category.

FD_CHECK_MASK: Used to suppress an alarm from being broadcast for single or multiple conditions that are active in the CHECK alarm category.

FD_FAIL_ALM: Used to broadcast a change in the associated active conditions, which are not masked, for the FAIL alarm category.

FD_OFFSPEC_ALM: Used to broadcast a change in the associated active conditions, which are not masked, for the OFFSPEC alarm category.

FD_MAINT_ALM: Used to broadcast a change in the associated active conditions, which are not masked, for the MAINT alarm category.

FD_CHECK_ALM: Used to broadcast a change in the associated active conditions, which are not masked, for the CHECK alarm category.

FD_FAIL_PRI: Specifies the priority of the FAIL alarm category.

FD_OFFSPEC_PRI: Specifies the priority of the OFFSPEC alarm category.

FD_MAINT_PRI: Specifies the priority of the MAINT alarm category.

FD_CHECK_PRI: Specifies the priority of the CHECK alarm category.

FD_SIMULATE: Diagnostic conditions can be manually supplied when simulation is enabled.

FD_RECOMMEN_ACT: Describes what actions can be taken to address an active diagnostic condition.

FD_EXTENDED_ACTIVE_1: For error conditions that have been selected in the Extended_Map_1 parameter, this parameter reflects those that have been detected as active.

FD_EXTENDED_MAP_1: Allows the user finer control in selecting multiple conditions contributing to a single condition that may be mapped for the various alarm categories.

SERIAL_NUMBER: Manufacturer specific read-only parameter that corresponds to “Magnetrol Serial Number” in the Transducer Block.

SOFTWARE_REV: Read-only parameter that corresponds to “Firmware Version” in the Transducer Block.

HARDWARE_REV: Read-only parameter that corresponds to “Hardware Version” in the Transducer Block.

COMPATIBILITY_REV: Read-only parameter that is optionally used when replacing field devices. The correct usage of this parameter presumes that the DEV_REV value of the replaced device is equal or lower than the COMPATIBILITY_REV value of the replacing device.

2.3 Transducer Block

The two TRANSDUCER blocks (TB) contained within the PULSAR Model R96 FF transmitter are custom blocks containing parameters that are pertinent to the transmitter itself.

TRANSDUCER Block 1 (used for level only operation) contains information such as the Configuration, Diagnostics, Calibration data, output level and Status information.

TRANSDUCER Block 2 contains parameters for volume measurement configuration.

The read-only parameters and read-write parameters within the TB are grouped in a useful configuration.

- The read-only parameters report the block status and operation modes.
- The read-write parameters affect both the operation of the function block and the transmitter itself.

NOTE:

The Transducer Block will automatically be changed to “Out of Service” when the local interface (keypad) is used to change a static parameter online. The Transducer Block must be manually placed back in service from the Host System to resume operation.

2.3.1 Transducer Block Parameters

The first six parameters in the TRANSDUCER Block are the universal parameters discussed in section 2.1.1. After the universal parameters, six additional parameters are required for Transducer Blocks. The most notable of these parameters are **UPDATE_EVT** and **BLOCK_ALM**. It should be noted that these six additional parameters must exist but do not have to be implemented.

An important device-specific parameter found later in the TRANSDUCER Block list is **PRESENT_STATUS**, which displays the status of the device. If more than one message exists, then the messages are displayed in priority order.

If **PRESENT_STATUS** indicates a problem, refer to Section 5.2, Troubleshooting.

For a complete list of Transducer Block Parameters, refer to table in the Appendix.

NOTE: The user should compare the DD file and revision number of the device with the HOST system to ensure they are at the same revision level.

Refer to the DD Revision Table Section 1.2.1.

Refer to Appendix A for a complete list of the two Transducer Block parameter sets.

2.3.2 Password Parameters

To change a parameter at the local user interface, host, or fieldbus interface, a value matching the user password must be entered (Default = 0). If a static parameter is changed from the local user interface, the Associated Transducer Block goes Out of Service (OOS).

Refer to the Section 4.3 for additional information regarding passwords.

After five minutes with no keypad activity, the entered password expires. However, the device must be placed back in service from the Host System.

2.3.3 PULSAR Model R96 FF Configuration Parameters

One of the main advantages of the PULSAR Model R96 FF Pulse Burst Radar transmitter is that the device can be delivered pre-configured to the user.

On the other hand, part of the advantage of FOUNDATION fieldbus™ is to provide the ability to monitor changes and make adjustments to a transmitter. The Fieldbus™ concept allows a user to make adjustments if deemed necessary.

2.3.4 PULSAR Model R96 FF Device-Specific Configuration Parameters

Refer to PULSAR Model R96 I/O Manual 58-602 for detailed information on the Model R96 device-specific configuration parameters.

2.4 Analog Input Block

The ANALOG INPUT (AI) block takes the PULSAR Model R96 FF input data, selected by channel number, and makes it available to other function blocks at its output.

The channel selections are:

Transducer Blocks	Process Variable	Channel Parameter Value (AI Blocks)
TB1 – Level	Level	1
	Distance	2
	Echo Strength	3
	Electronics Temperature	4
	Echo Margin	5
TB2 – Volume	Volume	6

2.4.1 AI Block Parameters

ST_REV: a read-only parameter that gives the revision level of the static data associated with the block. This parameter will be incremented each time a static parameter attribute value is written and is a vehicle for tracking changes in static parameter attributes.

TAG_DESC: a user assigned parameter that describes the intended application of any given block.

STRATEGY: a user assigned parameter that identifies groupings of blocks associated with a given network connection or control scheme.

ALERT_KEY: a user assigned parameter which may be used in sorting alarms or events generated by a block.

MODE_BLK: a structured parameter composed of the actual mode, the target mode, the permitted mode(s), and the normal mode of operation of a block.

- Target: The mode to “go to”
- Actual: The mode the “block is currently in”
- Permitted: Allowed modes that target may take on
- Normal: Most common mode for target

BLOCK_ERR: This parameter reflects the error status associated with the hardware or software components associated with a block. It is a bit string so that multiple errors may be shown.

PV: Either the primary analog value for use in executing the function, or a process value associated with it.

OUT: The primary analog value calculated as a result of executing the function block.

SIMULATE: Allows the transducer analog input or output to the block to be manually supplied when simulate is enabled. When simulate is disabled, the simulate value and status track the actual value and status. Refer to Section 2.4.5 for additional information.

XD_SCALE: The high and low scale values, Engineering Units, and number of digits to the right of the decimal point used with the value obtained from the transducer for a specified channel.

OUT_SCALE: The high and low scale values, Engineering Units, and number of digits to the right of the decimal point to be used in displaying the OUT parameter.

GRANT_DENY: Options for controlling access of host computers and local control panels to operating, tuning, and alarm parameters of the block.

IO_OPTS: Option which the user may select to alter input and output block processing.

STATUS_OPTS: Options which the user may select in the block processing of status.

CHANNEL: The number of the logical hardware channel that is connected to this I/O block. (This information defines the transducer to be used going to or from the physical world).

L_TYPE: Determines if the values passed by the transducer block to the AI block may be used directly (Direct), or if the value is in different units and must be converted linearly (Indirect), using the input range defined for the transducer and the associated output range.

LOW_CUT: Limit used in square root processing.

PV_FTIME: Time constant of a single exponential filter for the PV, in seconds.

FIELD_VAL: Raw value of the field device in % of PV range, with a status reflecting the Transducer condition before signal characterization (L_TYPE) or filtering (PV_FTIME).

UPDATE_EVT: This alert is generated by any change to the static data.

BLOCK_ALM: The block alarm is used for all configuration, hardware, or system problems in the block.

ALARM_SUM: The current alert status, unacknowledged states, unreported states, and disabled states of the alarms associated with the function block.

ACK_OPTION: Selection of whether alarms associated with the function block will be automatically acknowledged.

ALARM_HYS: Amount the PV must return within the alarm limits before the alarm condition clears. Alarm hysteresis expressed as a percent of the span of the PV.

HI_HI_PRI: Priority of the high high alarm.

HI_HI_LIM: The setting for high high alarm in engineering units.

HI_PRI: Priority of the high alarm.

HI_LIM: The setting for high alarm in engineering units

LO_PRI: Priority of the low alarm.

LO_LIM: The setting for low alarm in engineering units.

LO_LO_PRI: Priority of the low low alarm.

LO_LO_LIM: The setting for low low alarm in engineering units.

HI_HI_ALM: The status for high high alarm and its associated time stamp.

HI_ALM: Status for high alarm and associated time stamp.

LO_ALM: Status for low alarm and associated time stamp.

LO_LO_ALM: The status for low low alarm and its associated time stamp.

BLOCK_ERR_DESC: Reports more specific details regarding some errors reported through **BLOCK_ERR**.

The **MODE_BLK** parameter (within both the TB and AI Blocks) must be set to **AUTO** to pass the PV Value through the AI to the network.

Transducer scaling, called **XD_SCALE** is applied to the PV from the **CHANNEL** to produce the **FIELD_VAL** in percent.

- Valid **XD_SCALE** engineering units depend on the Channel Type.

2.4.2 AI Block Diagnostics

The AI blocks can display a **BLOCK_ERR** diagnostic when:

1. The Channel is not set correctly.
2. **XD_SCALE** does not have suitable engineering units.
3. The **SIMULATE** parameter is active.
4. AI block **MODE** is O/S (out of service).

NOTE: This can be caused by the Resource Block being OOS or the AI Block not scheduled for execution.

5. **L-TYPE** not set or set to Direct with improper **OUT_SCALE**.

The AI block uses the **STATUS_OPTS** setting and the “LIMIT” **ALARM PARAMETERS** value to modify the AI PV and **OUT QUALITY**.

A Damping Filter is a feature of the AI block. The **PV_FTIME** parameter is a time constant of a single exponential filter for the PV, in seconds. This parameter can be used to dampen out fluctuation in level due to excessive turbulence.

The AI block also has multiple **ALARM** functions that monitor the **OUT** parameter for out of bound conditions.

2.4.3 Local Display of Analog Input

The PULSAR Model R96 FF transmitter incorporates a useful feature that allows the Analog Input (AI) block Out values to be displayed on the local LCD.

NOTE: There are many reasons that AI block Out values can deviate from the measurement value originating in the Transducer block, and because the keypad and local display will only provide access to Transducer block parameters, there is no way to change (or view) the other fieldbus configuration items affecting the AI block output using the keypad and LCD.

In other words, these screens should only be considered as measured value indicators for configured transmitters. For example:

- The screens are not used for commissioning or diagnostic/troubleshooting purposes.
- Prior to full fieldbus configuration (transmitter assigned a permanent address, AI block(s) configured and scheduled for execution, etc.), the value displayed will be 0 with “BAD: OUT OF SERVICE” indicated. It will not reflect the transducer measurement.

2.4.3.1 AI Out Display Screens

The Analog Input Block Out values can be conditionally displayed as part of the “rotating” home menu screens. A representative example is shown at left.

The screens will be formatted as shown with:

- Physical Device Tag (Selectable)
- Measured Value Status (Bad, Good, Uncertain)
- Bar Graph

For example, “AI1_Level” would be the most commonly used AI Out screen.

“AI2---” would be displayed when the channel value is 0 [uninitialized] for AI block 2.

Because the Model R96 transmitter has six (6) Analog Input blocks, any or all of which may be used in particular applications, a Transducer block parameter controls which AI block Out values will be displayed on the LCD.

Any or all (or none) of the AI block Out values can be selected for display on the rotating home menu.

NOTE: In the photo at left, status is shown as “Bad out of Service”. This message would be shown prior to commissioning.



LCD Home Screen

2.4.4 AI Block Configuration

Below are examples of various typical AI Block configurations.

Example 1:
standard configuration for transmitter with tank height TH inches or cm.

[setup by factory as part of final assembly procedure]

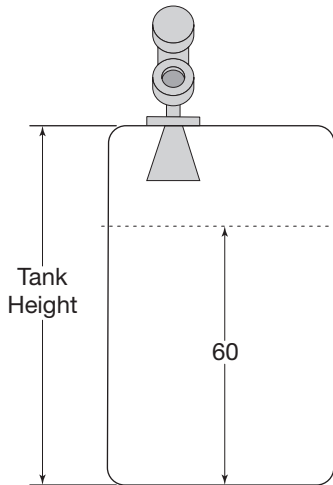

Transducer Block + LCD Level	AI Block Output [To FF segment]
60 [in / cm]	100%
Tank Height = inches or cm	
0 [in / cm]	0%

Configuration	
Tank Height	TH
Bottom Blocking Distance	0
XD Scale EU at 0%	0
XD Scale EU at 100%	60
XD Scale Units	in/cm
Out Scale EU at 0%	0
Out Scale EU at 100%	100
Out Scale Units	%
L Type	Indirect

Example 2:
end user desires 0 to 100% output for a subset of the measurable region

[e.g., for a chamber application]

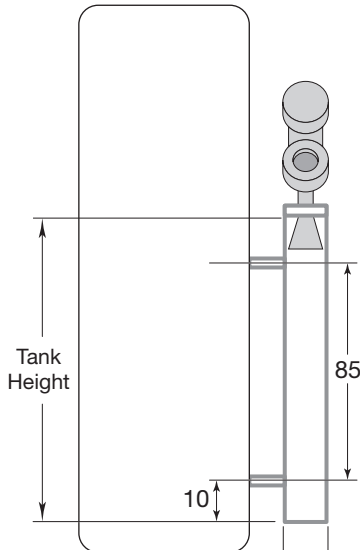

Transducer Block + LCD Level	AI Block Output [To FF segment]
85 cm	100%
0 cm	0%

Configuration	
Tank Height	TH
Bottom Blocking Distance	10
XD Scale EU at 0%	0
XD Scale EU at 100%	85
XD Scale Units	cm
Out Scale EU at 0%	0
Out Scale EU at 100%	100
Out Scale Units	%
L Type	Indirect

Example 3:
same configuration as previous except Direct [no] scaling setup in AI block

Output to FF segment is in cm

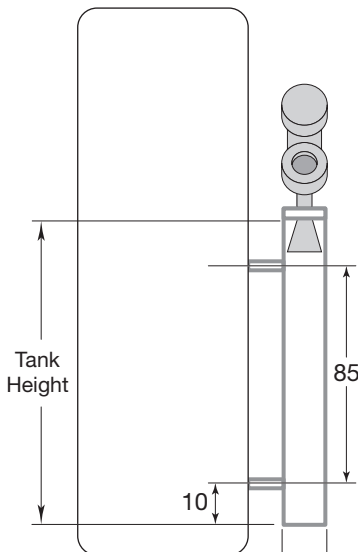

Transducer Block + LCD Level	AI Block Output [To FF segment]
85 cm	85 cm
0 cm	0 cm

Configuration	
Tank Height	TH
Bottom Blocking Distance	10
XD Scale EU at 0%	0
XD Scale EU at 100%	85
XD Scale Units	cm
Out Scale EU at 0%	0
Out Scale EU at 100%	85
Out Scale Units	cm
L Type	Direct

2.4.5 Simulation Feature

The PULSAR Model R96 with FOUNDATION fieldbus™ supports the Simulate feature in the Analog Input block. The Simulate feature is typically used to exercise the operation of an AI block by simulating a TRANSDUCER block input.

This feature cannot be activated without the placement of a hardware jumper. A jumper is provided in the “Run” position of the PULSAR Model R96, and is placed under the display module. To enable the simulation feature, remove display module and move the jumper to the “SIM” position. Refer to figure at left for jumper location.

NOTE: A BLOCK_ERR of “Simulation Active” in the Resource Block does not mean simulation is active—it merely indicates that the simulation (hardware) enabling jumper is present.

- The jumper may be removed to eliminate the BLOCK_ERR and placed back in the “Run” position.



Place Jumper in the “SIM” position to enable simulation.

2.5 PID Block

The PID Function Block contains the logic necessary to perform Proportional/Integral/Derivative (PID) control. The block provides filtering, set point and rate limits, feed-forward support, output limits, error alarms, and mode shedding.

Although most other function blocks perform functions specific to the associated device, the PID block may reside in any device on the network. This includes a valve, a transmitter, or the host itself.

The PULSAR Model R96 FF PID Block implementation follows the specifications documented by the Fieldbus Foundation.

2.5.1 PID Block Parameters

ACK_OPTION: Used to set auto acknowledgement of alarms.

ALARM_HYS: The amount the alarm value must return to before the associated active alarm condition clears.

ALARM_SUM: The summary alarm is used for all process alarms in the block.

ALERT_KEY: The identification number of the plant unit.

BAL_TIME: The specified time for the internal working value of bias to return to the operator set bias.

BKCAL_IN: The analog input value and status for another blocks BKCAL_OUT output.

BKCAL_HYS: The amount the output must change away from its output limit before the limit status is turned off, expressed as a percent of the span of the output.

BKCAL_OUT: The value and status required by the BKCAL_IN input for another block.

BLOCK_ALM: Used for all configuration, hardware, or system problems in the block.

BLOCK_ERR: Reflects the error status associated with the hardware or software components associated with a block.

BYPASS: Used to override the calculation of the block.

CAS_IN: The remote setpoint value from another block.

CONTROL_OPTS: Allows one to specify control strategy options.

DV_HI_ALM: The DV HI alarm data.

DV_HI_LIM: The setting for the alarm limit used to detect the deviation high alarm condition.

DV_HI_PRI: The priority of the deviation high alarm.

DV_LO_ALM: The DV LO alarm data.

DV_LO_LIM: The setting for the alarm limit used to detect the deviation low alarm condition.

DV_LO_PRI: The priority of the deviation low alarm.

FF_GAIN: The feedforward gain value.

FF_SCALE: The high and low scale values associated with FF_VAL.

FF_VAL: The feedforward control input value and status.

GAIN: The proportional gain value. This value cannot equal zero.

GRANT_DENY: Options for controlling access of host computers to alarm parameters of the block.

HI_ALM: The HI alarm data.

HI_HI_ALM: The HI HI alarm data.

HI_HI_LIM: The setting for the alarm limit used to detect the HI HI alarm condition.

HI_HI_PRI: The priority of the HI HI Alarm.

HI_LIM: The setting for the alarm limit used to detect the HI alarm condition.

HI_PRI: The priority of the HI alarm.

IN: The connection for the PV input from another block.

LO_ALM: The LO alarm data.

LO_LIM: The setting for the alarm limit used to detect the LO alarm condition.

LO_LO_ALM: The LO_LO alarm data.

LO_LO_LIM: The setting for the alarm limit used to detect the LO_LO alarm condition.

LO_LO_PRI: The priority of the LO_LO alarm.

LO_PRI: The priority of the LO alarm.

MODE_BLK: The actual, target, permitted, and normal modes of the block.

OUT: The block input value and status.

OUT_HI_LIM: The maximum output value allowed.

OUT_LO_LIM: The minimum output value allowed.

OUT_SCALE: The high and low scale values associated with OUT.

PV: The process variable use in block execution.

PV_FTIME: The time constant of the first order PV filter.

PV_SCALE: The high and low scale values associated with PV.

RATE: The derivative action time constant.

RCAS_IN: Target setpoint and status that is provided by a supervisory host.

RCAS_OUT: Block setpoint and status that is provided to a supervisory host.

RESET: The integral action time constant.

ROUT_IN: Block output that is provided by a supervisory host.

ROUT_OUT: Block output that is provided to a supervisory host.

SHED_OPT: Defines action to be taken on remote control device timeout.

SP: The target block setpoint value.

SP_HI_LIM: The highest SP value allowed.

SP_LO_LIM: The lowest SP value allowed.

SP_RATE_DN: Ramp rate for downward SP changes.

SP_RATE_UP: Ramp rate for upward SP changes.

STATUS_OPTS: Allows one to select options for status handling and processing.

STRATEGY: Can be used to identify grouping of blocks.

ST_REV: The revision level of the static data associated with the function block.

TAG_DESC: The user description of the intended application of the block.

TRK_IN_D: Discrete input that initiates external tracking.

TRK_SCALE: The high and low scale values associated with TRK_VAL.

TRK_VAL: The value applied to OUT in LO mode.

UPDATE_EVT: This alert is generated by any changes to the static data.

BLOCK-ERR-DESC: Reports more specific details regarding some errors reported through BLOCK_ERR.

3.0 Advanced Function Blocks

3.1 Arithmetic Block (AR)

The Arithmetic function block provides the ability to configure a range extension function for a primary input and applies the nine different arithmetic types as compensation to or augmentation of the range extended input.

The nine arithmetic functions are:

- Flow Compensation Linear
- Flow Compensation Square Root
- Flow Compensation Approximate
- Btu Flow
- Traditional Multiply and Divide
- Average
- Summer
- Fourth Order Polynomial
- Simple HTG Compensate Level

ST_REV: The revision level of the static data associated with the function block. The revision value will increment each time a static parameter value in the block is changed.

TAG_DESC: The user description of the intended application of the block.

STRATEGY: The strategy field can be used to identify grouping of blocks. This data is not checked or processed by the block.

ALERT_KEY: The identification number of the plant unit. This information may be used in the host for sorting alarms, etc.

MODE_BLK: The actual, target, permitted, and normal modes of the block.

- Target: The mode to “go to”
- Actual: The mode the “block is currently in”
- Permitted: Allowed modes that target may take on
- Normal: Most common mode for target

BLOCK_ERR: This parameter reflects the error status associated with the hardware or software components associated with a block. It is a bit string so that multiple errors may be shown.

PV: The primary analog value for use in executing the function, or a process value associate with it.

OUT: The analog output value and status.

PRE_OUT: Displays what would be the OUT value if the mode was “Auto” or lower.

PV_SCALE: Associated with the PV.

OUT_RANGE: The high and low scale values, engineering units code, and number of digits to the right of the decimal point associated with OUT.

GRANT_DENY: Options for controlling access of host computers and local control panels to operating, tuning, and alarm parameters of the block.

INPUT_OPTIONS: Option bit string for handling the status of the auxiliary inputs.

IN: The block input value and status.

IN_LO: Input of the low range transmitter, in a range extension application.

IN-1, IN-2, IN-3: Inputs combined with the PV in a section of four term math functions.

RANGE_HI: Constant value above which the range extension has switch to the high range transmitter.

RANGE_LO: Constant value below which the range extension has switch to the high range transmitter.

BIAS_IN_1: The bias value for IN_1.

GAIN_IN_1: The proportional gain (multiplier) value for IN_1.

BIAS_IN_2: The bias value for IN_2.

GAIN_IN_2: The proportional gain (multiplier) value for IN_2.

BIAS_IN_3: The bias value for IN_3.

GAIN_IN_3: The proportional gain (multiplier) value for IN_3.

COMP_HI_LIM: Determines the high limit of the compensation input.

COMP_LO_LIM: Determines the low limit of the compensation input.

ARITH_TYPE: The set of nine arithmetic functions applied as compensation to or augmentation of the range extended input.

BAL_TIME: Specifies the time for a block value to match an input, output, or calculated value or the time for dissipation of the internal balancing bias.

BIAS: The bias value is used to calculate the output.

GAIN: The gain value is used to calculate the output.

OUT_HI_LIM: The maximum output value allowed.

OUT_LO_LIM: The minimum output value allowed.

UPDATE_EVT: This alert is generated by any changes to the static data.

BLOCK_ALM: Used for all configuration, hardware, connection failure, or system problem in the block.

BLOCK_ERR_DESC: Reports more specific details regarding some errors reported through BLOCK_ERR.

3.2 Input Selector Block (IS)

The Input Selector (IS) function block can be used to select the first good, maximum, minimum, or average of as many as four input values and place it at the output. The block supports signal status propagation. (There is no process alarm detection in the Input Selector function block.)

ST_REV: The revision level of the static data associated with the function block. The revision value will be incremented each time a static parameter value in the block is changed.

TAG_DESC: The user description of the intended application of the block.

STRATEGY: The strategy field can be used to identify grouping of blocks. This data is not checked or processed by the block.

ALERT_KEY: The identification number of the plant unit. This information may be used in the host for sorting alarms, etc.

MODE_BLK : The actual, target, permitted, and normal modes of the block.

- Target: The mode to “go to”
- Actual: The mode the “block is currently in”
- Permitted: Allowed modes that target may take on
- Normal: Most common mode for target

BLOCK_ERR: This parameter reflects the error status associated with the hardware or software components associated with a block. It is a bit string, so that multiple errors may be shown.

OUT: The block output value and status.

OUT_RANGE: High and low scale values, engineering units code, and number of digits to the right of the decimal point associated with OUT

GRANT_DENY: Options for controlling access of host computers and local control panels to operating, tuning, and alarm parameters of the block.

STATUS_OPTIONS : Allows you to select options for status handling and processing. The supported status options for the input selector block are: “Use Uncertain as Good”, “Uncertain if Man mode.”

IN_1: The block input value and status.

IN_2: The block input value and status.

IN_3: The block input value and status.

IN_4: The block input value and status.

DISABLE_1: Parameter to switch off the input from being used 0- Use, 1 - Disable.

DISABLE_2: Parameter to switch off the input from being used 0- Use, 1 - Disable.

DISABLE_3: Parameter to switch off the input from being used 0- Use, 1 - Disable.

DISABLE_4: Parameter to switch off the input from being used 0- Use, 1 - Disable.

SELECT_TYPE: Determines the selector action; First good, Minimum, Maximum, Middle, Average.

MIN_GOOD: The minimum number of inputs which are “good” is less than the value of MIN_GOOD then set the OUT status to “bad”.

SELECTED: The integer indicating the selected input number.

OP_SELECT: An operator settable parameter to force a given input to be used.

UPDATE_EVT: This alert is generated by any change to the static data.

BLOCK_ALM: The block alarm is used for all configuration, hardware, connection failure, or system problems in the block.

BLOCK_ERR_DESC: Reports more specific details regarding some errors reported through BLOCK_ERR.

3.3 Signal Characterizer Block (SC)

The Signal Characterizer (SC) function block characterizes or approximates any function that defines an input/output relationship. The function is defined by configuring as many as 21 X, Y coordinates. The block interpolates an output value for a given input value using the curve defined by the configured coordinates. Two separate analog input signals can be processed simultaneously to give two corresponding separate output values using the same defined curve.

ST_REV: The revision level of the static data associated with the function block. The revision value will be incremented in each time a static parameter value in the block is changed.

TAG_DESC: The user description of the intended application of the block.

STRATEGY: The strategy field can be used to identify grouping of blocks. This data is not checked or processed by the block.

ALERT_KEY: The identification number of the plant unit. This information may be used in the host for sorting alarms, etc.

MODE_BLK: The actual, target, permitted, and normal modes of the block.

- Target: The mode to “go to”
- Actual: The mode the “block is currently in”
- Permitted: Allowed modes that target may take on
- Normal: Most common mode for target

BLOCK_ERR: This parameter reflects the error status associated with the hardware or software components associated with a block. It is a bit string so that multiple errors may be shown.

OUT1: The block output value and status.

OUT2: The block output value and status.

X_RANGE: The display scaling of the variable corresponding to the x-axis for display. It has no effect on the block.

Y_RANGE: The display scaling of the variable corresponding to the y-axis for display. It has no effect on the block.

GRANT_DENY: Options for controlling access of host computers and local control panels to operating, tuning, and alarm parameters of the block.

IN1: The block input value and status.

IN2: The block input value and status.

SWAP_2: Changes the algorithm in such a way that IN_2 corresponds to “y” and OUT_2 to “x”.

CURVE_X : Curve input points. The “x” points of the curve are defined by an array of 21 points.

CURVE_Y: Curve input points. The “y” points of the curve are defined by an array of 21 points.

UPDATE_EVT: This alert is generated by any changes to the static data.

BLOCK_ALM: The block alarm is used for all configuration, hardware, connection failure, or system problems in the block.

BLOCK_ERR_DESC: Reports more specific details regarding some errors reported through BLOCK_ERR.

4.0 Model R96 Transmitter Configuration

Although the PULSAR Model R96 transmitter can be delivered pre-configured from the factory, it can also be easily reconfigured in the shop or at the installation using the local LCD/Keypad. Bench configuration provides a convenient and efficient way to set up the transmitter before going to the tank site to complete the installation.

NOTE: The transmitter can be configured without the antenna connected. Disregard any diagnostic indicators that may appear.

4.1 Configuration Information

To utilize the QuickStart menu available on the PULSAR Model R96, some key information is required for configuration.

Gather the information and complete the following operating parameters table before beginning configuration.

NOTES: The QuickStart menu is available for Level Only applications.

1. These configuration steps are not necessary if the transmitter was pre-configured prior to shipment.

Display	Question	Answer
Level Units	What units of measurement will be used?	_____
Tank Height	What is the tank height?	_____
Antenna Model	What type of antenna is being used? Select first 7 digits of Model number. (See nameplate on side of antenna)	_____
Antenna Extension	What is maximum nozzle length for which the antenna can be used? Select last 3 digits of Model number. (See nameplate on side of antenna)	_____
Antenna Mount	Is the antenna mounting NPT, BSP, or flanged?	_____
Dielectric	What is the dielectric of the process medium?	_____

4.2 Menu Traversal and Data Entry

The four push buttons offer various forms of functionality for navigation and data entry.

The Model R96 user interface is hierarchical in nature, best described as a tree structure. Each level in the tree contains one or more items. Items are either menu labels or parameter names.

- Menu labels are presented in all CAPITAL LETTERS
- Parameters are Capital Words



4.2.1 Navigating the Menu

- ⇧ **UP** moves to the previous item in the menu branch.
- ⇩ **DOWN** moves to the next item in the menu branch.
- ⇐ **BACK** moves back one level to the previous (higher) branch item.
- ⇒ **ENTER** enters into the lower level branch or switches to the entry mode. Holding the ENTER down on any highlighted menu name or parameter will show help text for that item.

4.2.2 Data Selection





This method is used for selecting configuration data from a specific list.

- ⇧ **UP** and ⇩ **DOWN** to navigate the menu and highlight the item of interest
- ⇒ **ENTER** allows modification of that selection
- ⇧ **UP** and ⇩ **DOWN** to choose new data selection
- ⇒ **ENTER** to confirm selection

Use ⇐ **BACK** (Escape) key at any time to abort the procedure and escape to previous branch item.

4.2.3 Entering Numeric Data Using Digit Entry

This method is used to input numeric data, e.g., Tank Height.





Push button		Keystroke Action
	Up	Moves up to the next highest digit (0,1,2,3,....,9 or decimal point). If held down the digits scroll until the push button is released.
	Down	Moves up to the next lowest digit (0,1,2,3,....,9 or decimal point). If held down the digits scroll until the push button is released.
	Back	Moves the cursor to the left and deletes a digit. If the cursor is already at the leftmost position, then the screen is exited without changing the previously saved value.
	Enter	Moves the cursor to the right. If the cursor is located at a blank character position, the new value is saved.

All numeric values are left-justified, and new values are entered from left to right. A decimal point can be entered after the first digit is entered, such that .9 is entered as 0.9.

Some configuration parameters can have a negative value. In this case, the leftmost position is reserved for the sign (either "-" for a negative value, or "+" for a positive value).

4.2.4 Entering Numeric Data Using Increment/Decrement





Use this method to input the following data into parameters such as Failure Alarm Delay.

Push button		Keystroke Action
	Up	Increments the displayed value. If held down the digits scroll until the push button is released. Depending on which screen is being revised, the increment amount may increase by a factor of 10 after the value has been incremented 10 times.
	Down	Decrements the displayed value. If held down the digits scroll until the push button is released. Depending on which screen is being revised, the decrement amount may increase by a factor of 10 after the value has been decremented 10 times.
	Back	Returns to the previous menu without changing the original value, which is immediately redisplayed.
	Enter	Accepts the displayed value and returns to the previous menu.

4.2.5 Entering Character Data

This method is used for parameters requiring alphanumeric character entry, such as for entering tags, etc.

General Menu Notes:

Push button		Keystroke Action
	Up	Moves to the previous character (Z...Y...X...W). If held down, the characters scroll until the push button is released.
	Down	Moves to the next item character (A...B...C...D). If held down, the characters scroll until the push button is released.
	Back	Moves the cursor back to the left. If the cursor is already at the leftmost position, then the screen is exited without changing the original tag characters.
	Enter	Moves the cursor forward to the right. If the cursor is at the rightmost position, then the new tag is saved.

4.3 Password Protection

The PULSAR Model R96 transmitter has three levels of password protection to restrict access to certain portions of the menu structure that affect the operation of the system. The user password can be changed to any numerical value up to 59999. When the transmitter is programmed for password protection, a password is required whenever configuration values are changed.

User Password

The User Password allows the customer to limit access to the basic configuration parameters from both the local and fieldbus interfaces.

The default User Password installed in the transmitter at the factory is 0. (With a password of 0, the transmitter is not password protected and any value in the basic user menus can be adjusted without entering a confirming password.)

NOTE: If a User Password is not known or has been misplaced, the menu item New Password in the DEVICE SETUP/ADVANCED CONFIG menu displays an encrypted value representing the present password. Contact Technical Support with this encrypted password to retrieve the original User Password.

Advanced Password

Certain portions of the menu structure that contain more advanced parameters are further protected by an Advanced Password.

This password will be provided, when necessary, by Factory technical support.

Factory Password

Calibration-related and other factory settings are further protected by a Factory Password.

4.4 Model R96 Menu: Step-By-Step Procedure

The following tables provide a complete explanation of the software menus displayed by the PULSAR transmitter. The menu layout is similar between the local Keypad/LCD interface, the DD, and the DTM.

Use these tables as a step-by-step guide to configure the transmitter based on the desired measurement type from the following selections:

- Level Only
- Volume & Level

HOME SCREEN

The Home Screen consists of a “slide show” sequence of Measured Values screens which are rotated at 2-second intervals. Each Home Measured Value screen can present up to four information items:

- **physical device tag**
- **measured value**
Label, Numerical Value, Units
- **present status**
Will be displayed as text
- **bar graph** (shown in %)
Bar graph is only displayed on AI_OUT screens shown in % based on XD scale configuration.

The Home Screen presentation can be customized by viewing or hiding some of these items.

At left is an example of a Home Screen for a Model R96 configured for a Level Only application.



Home Screen

MAIN MENU

Pressing any key on the Home Screen will present the Main Menu, consisting of three basic menu labels shown in all capital letters.

DEVICE SETUP

DIAGNOSTICS

MEASURED VALUES

As shown, the reverse video represents a cursor identifying the selected item, which will appear in reverse video on the LCD. The actions of the keys at this point are:



Main Menu Screen

Push button		Keystroke Action
↑	Up	No action as the cursor is already at the first item in the MAIN MENU
↓	Down	Moves the cursor to DIAGNOSTICS
←	Back	Moves back to HOME SCREEN, the level above MAIN MENU
→	Enter	Presents the selected item, DEVICE SETUP

- NOTES:
1. Items and parameters that are shown in lower level menus will depend on the Measurement Type chosen. Those parameter not applicable to the present Measurement Type will be hidden.
 2. Holding down the Enter key when the cursor is highlighted over a parameter or menu will provide additional information about that item.

DEVICE SETUP

Choosing DEVICE SETUP from the MAIN MENU will result in an LCD presentation as shown at left.

The small down arrow shown at the right hand side of the screen is the indication that more items are available below and can be accessed by pressing the DOWN key.

Section 4.5 shows the entire tree menu for the Model R96 DEVICE SETUP Menu.

DIAGNOSTICS

Refer to Section 5.0.

MEASURED VALUES

Allows the user to scroll through all of the available measured values for the measurement type chosen.



Device Setup Screen

4.5 Model R96 Configuration Menu — Device Setup

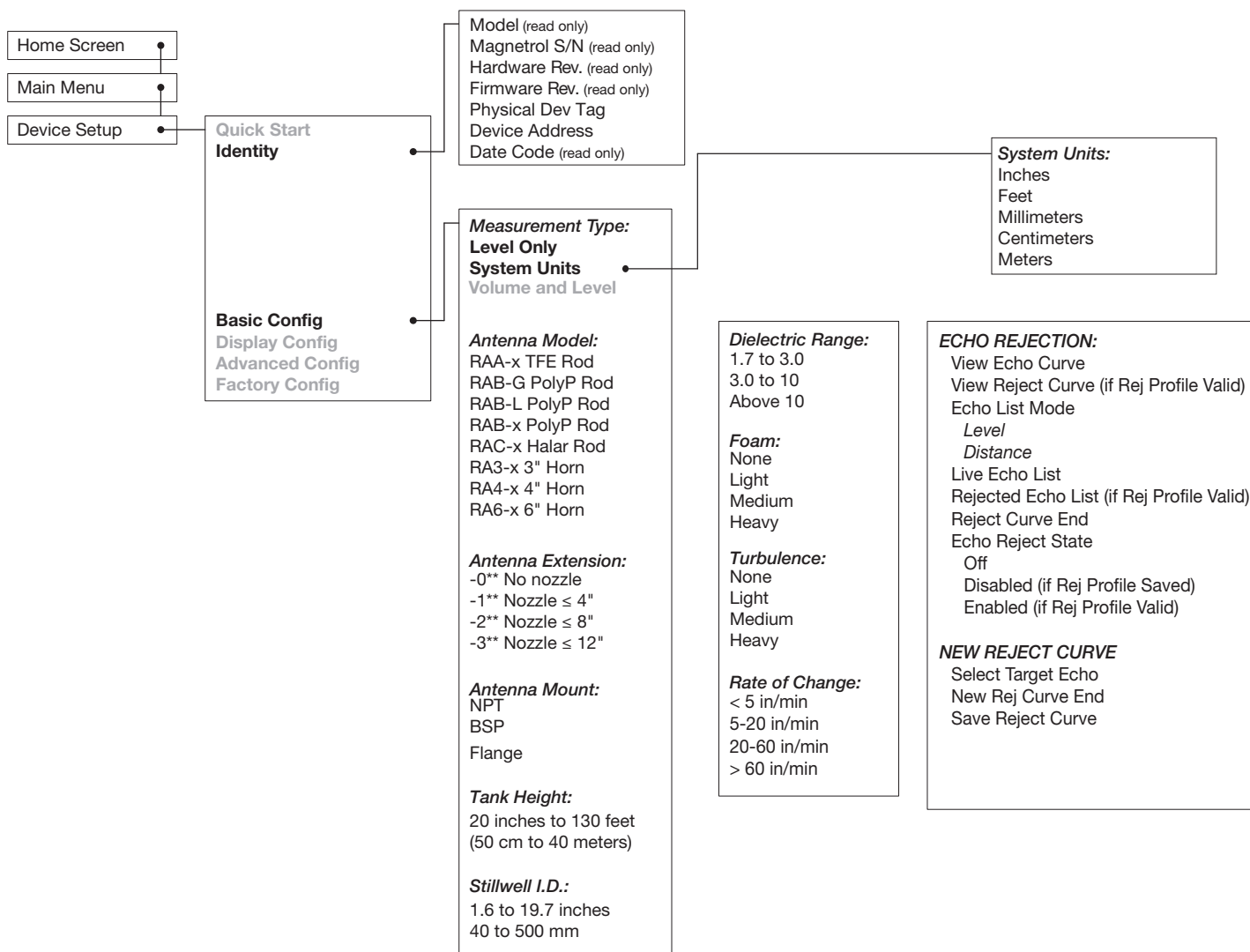
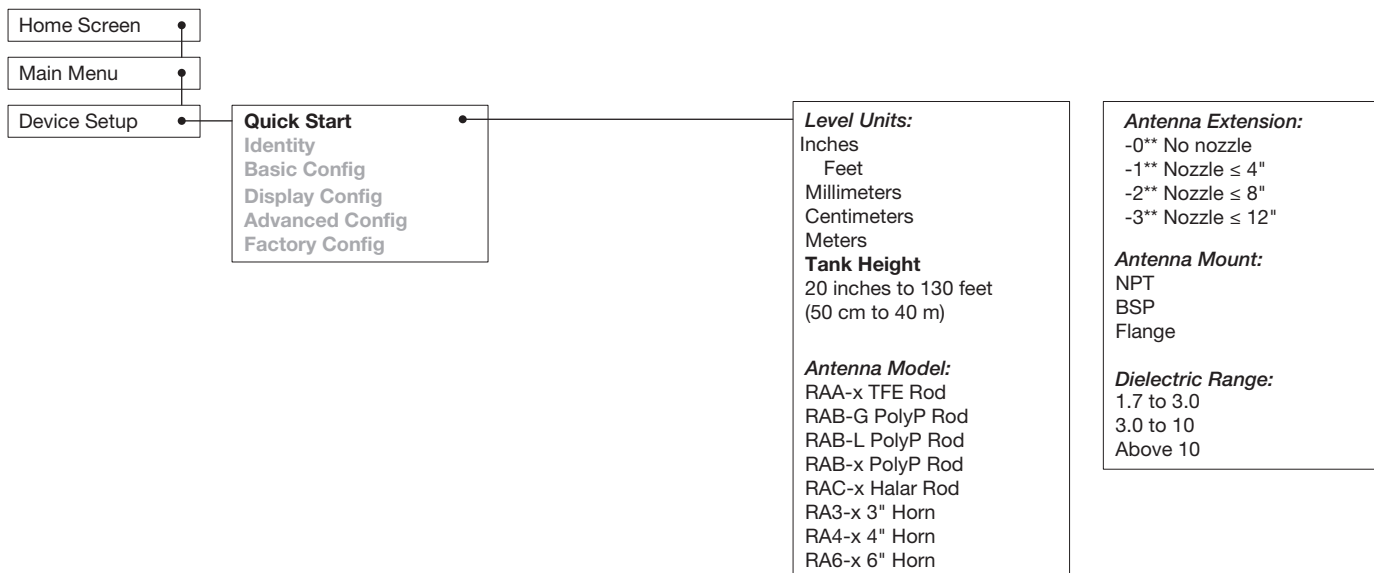

4.5 Model R96 Configuration Menu — Device Setup

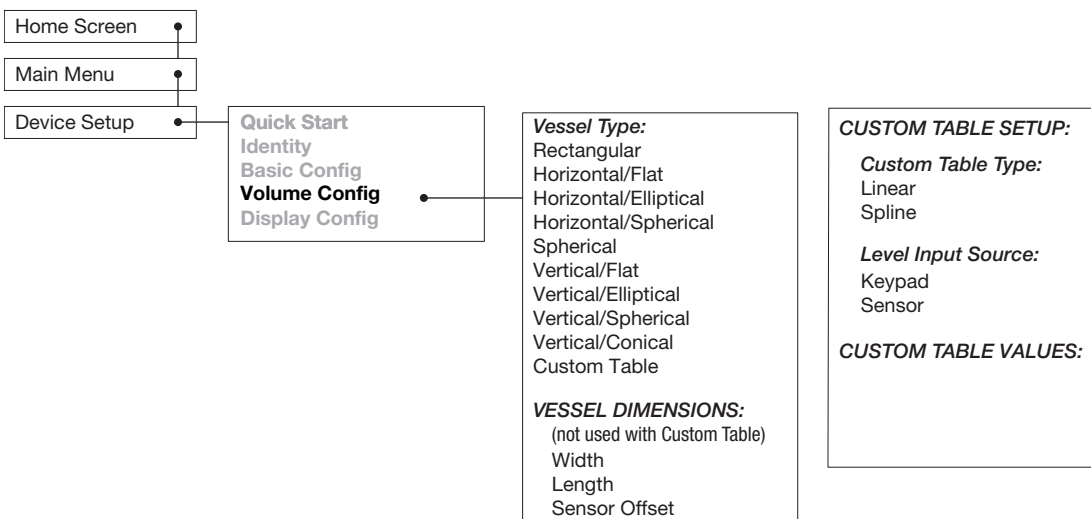
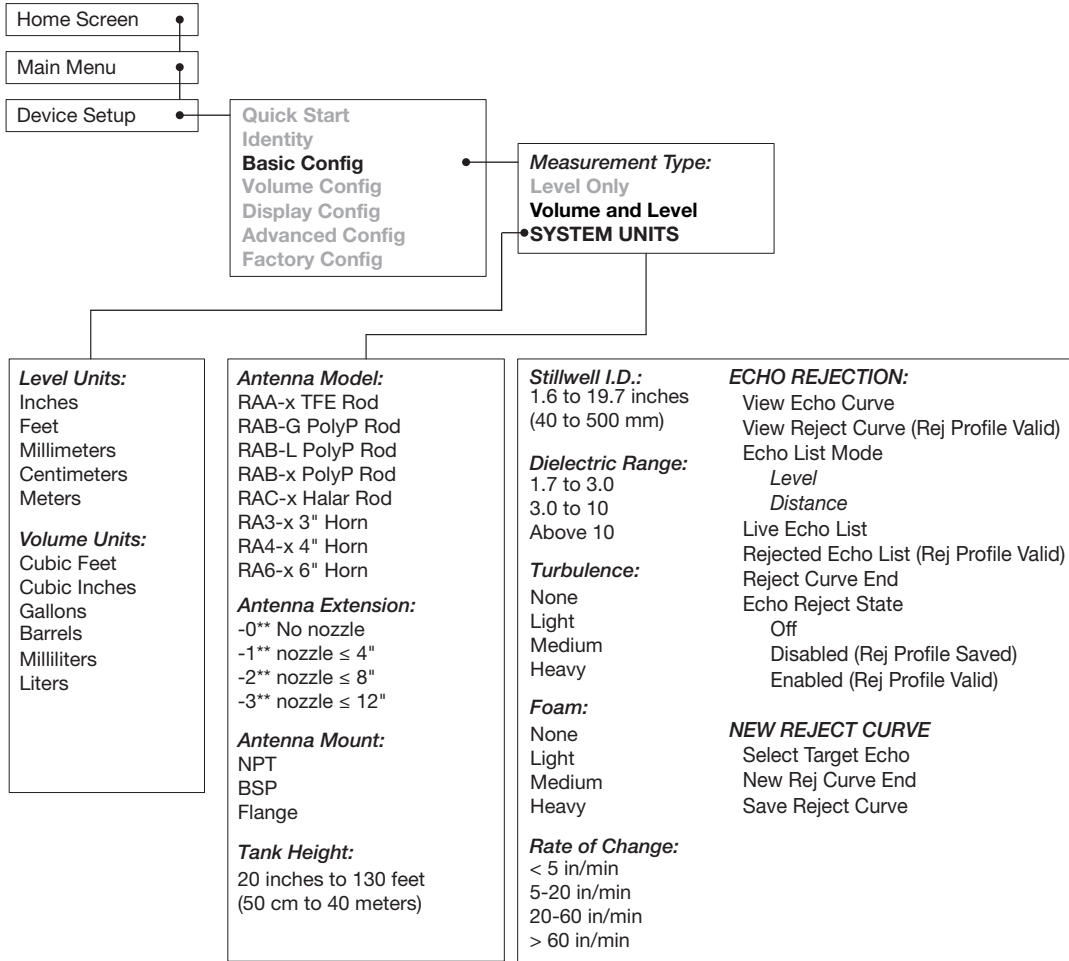

4.5 Model R96 Configuration Menu — Device Setup

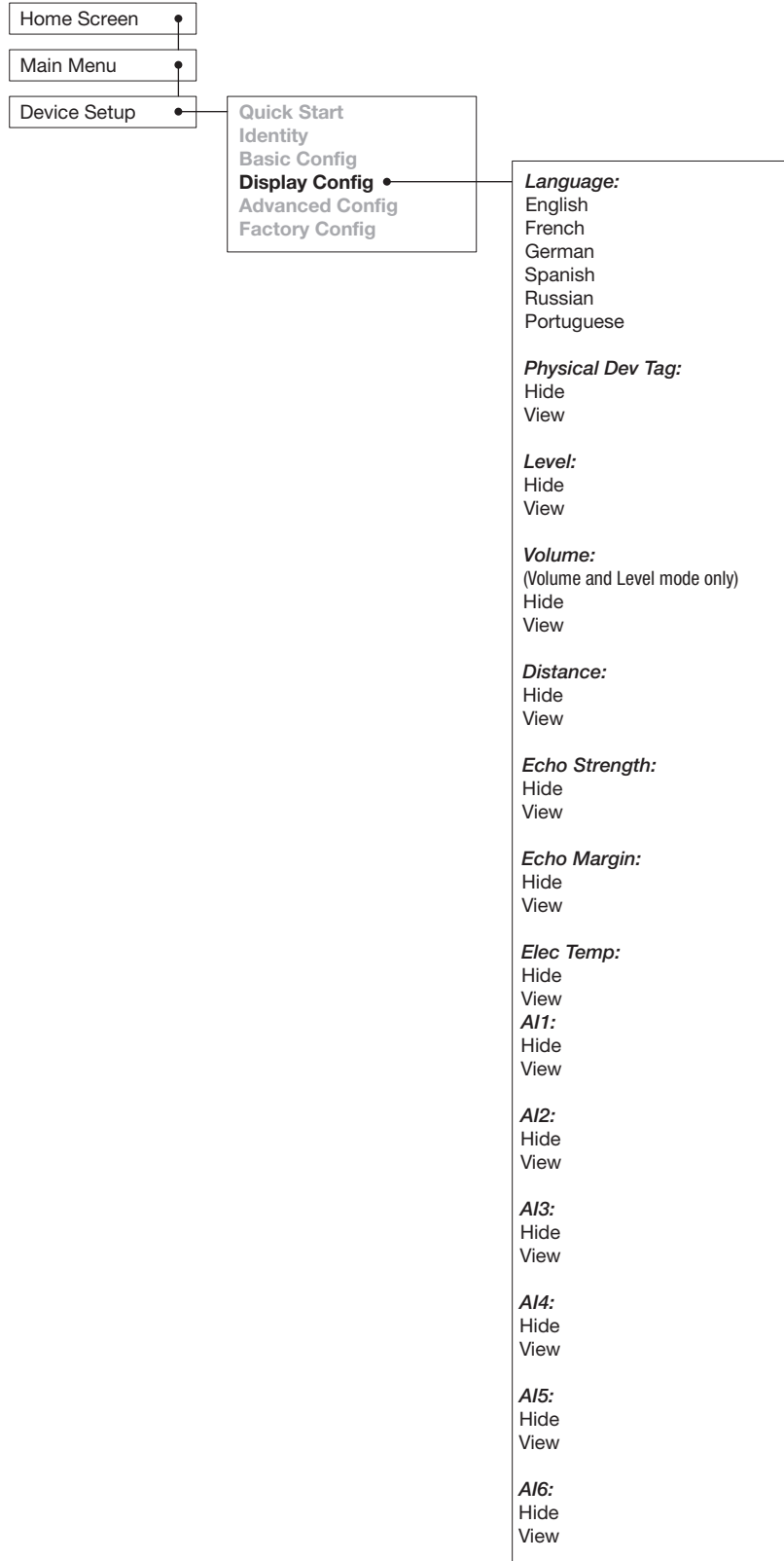

4.5 Model R96 Configuration Menu — Device Setup

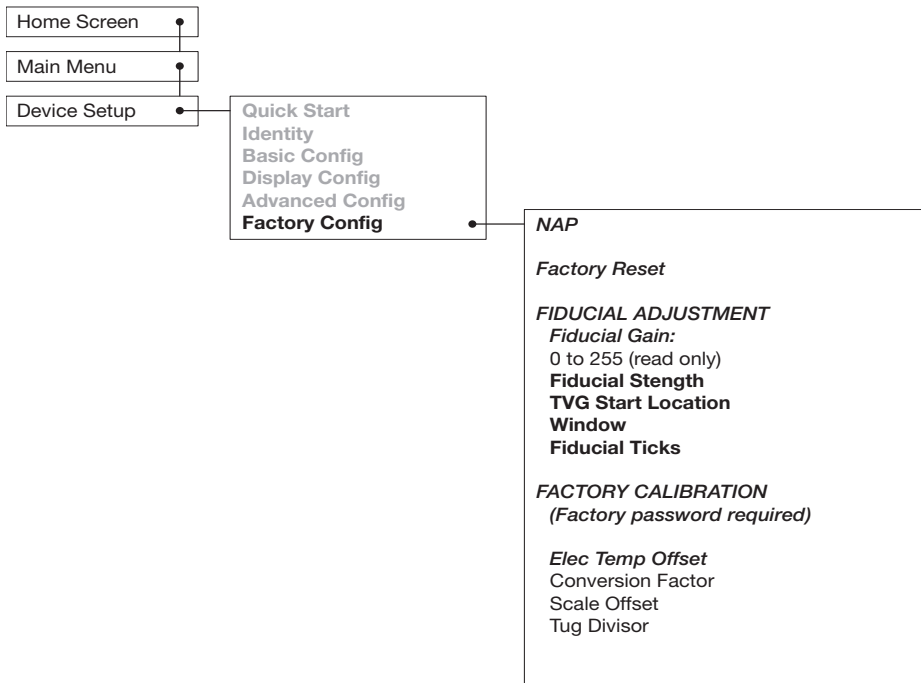
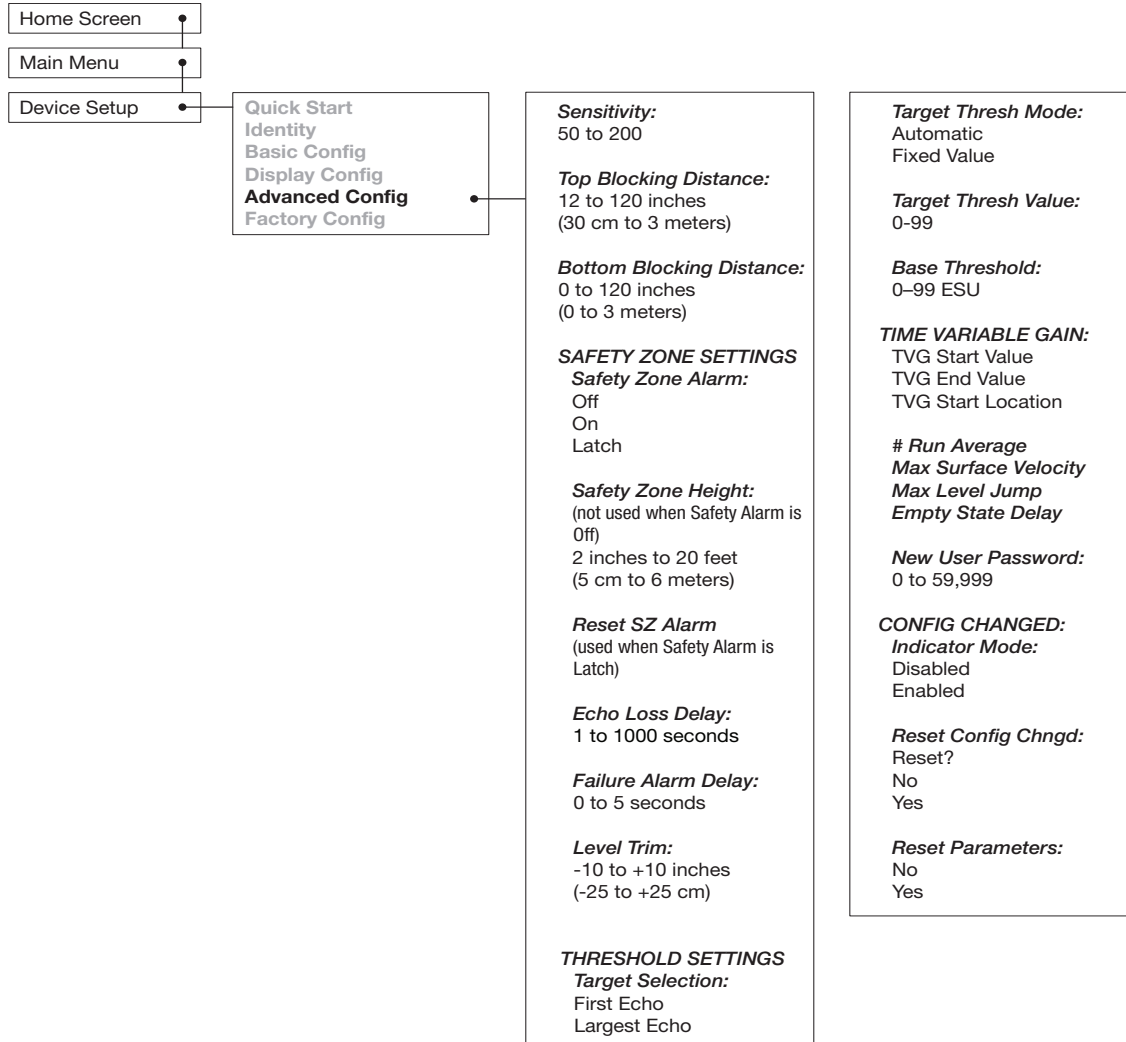

5.0 Troubleshooting and Diagnostics

The PULSAR Model R96 transmitter is designed and engineered for trouble-free operation over a wide range of operating conditions. The transmitter continuously runs a series of internal self-tests and displays helpful messages on the large graphic liquid crystal display (LCD) when attention is required.

The combination of these internal tests and diagnostics messages offer a valuable proactive method of troubleshooting. The device not only tells the user what is wrong, but also, and more importantly, offers suggestions on how to solve the problem.

All of this information can be obtained directly from the transmitter on the LCD, remotely from the Fieldbus host system, or by utilizing PACTware and the PULSAR Model R96 DTM.

PACTware™ PC Program

The PULSAR Model R96 offers the ability to perform more advanced diagnostics such as Trending and Echo Curve analysis using a PACTware DTM. This is a powerful troubleshooting tool that can aid in the resolution of any diagnostic indicators that may appear.

5.1 Diagnostic Parameters

As mentioned above, the PULSAR Model R96 measurement engine runs through a series of self-tests and will detect and report faulty operation. The TRANSDUCER BLOCK displays this diagnostic information in the STATUS INDICATOR parameter. Refer to Section 5.1.3 for more information on specific diagnostic indicators.

Note: Within the TRANSDUCER BLOCK, BLOCK_ERROR is not used except for indicating Out of Service (OOS).

For the first few seconds after power is applied to the Model R96 transmitter, the LEVEL_STATUS/QUALITY is “Uncertain,” the SUB_STATUS is “Initial value,” and the LIMIT attribute is shown as “Constant.”

When the Model R96 is operating properly, the LEVEL_STATUS/QUALITY is shown as “GOOD,” and the SUB_STATUS is “Non-Specific.”

While changing any transmitter parameters using the local display or through a system configuration tool (with the MODE_BLK in OOS), the output might be inaccurate because of the changing parameters. When the device is set to OOS, the TRANSDUCER BLOCK will still output level but the QUALITY will be shown as “Bad” and the SUB_STATUS is “Out of Service.”

If the Model R96 fails to find a measurable level, the TRANSDUCER BLOCK maintains the last good value as the output and flags the failure. The QUALITY is “Bad,” the SUB_STATUS is “Device failure” for no level, and the LIMIT attribute is “Constant.”

Refer to Section 5.2 for additional information.

5.1.1 Diagnostics (Namur NE 107)

The PULSAR Model R96 transmitter includes an exhaustive list of Diagnostic Indicators which follow the NAMUR NE 107 guidelines.

NAMUR is an international user association of automation technology in process industries, whose goal is to promote the interest of the process industry by pooling experiences among its member companies. In doing so, this group promotes international standards for devices, systems, and technologies.

The objective of NAMUR NE 107 was essentially to make maintenance more efficient by standardizing diagnostics information from field devices. This was initially integrated via FOUNDATION Fieldbus, but the concept applies regardless of the communication protocol.

According to the NAMUR NE107 recommendation, "Self Monitoring and Diagnosis of Field Devices," fieldbus diagnostic results should be reliable and viewed in the context of a given application. The document recommends categorizing internal diagnostics into four standard status signals:

- Failure
- Function Check
- Out of Specification
- Maintenance required

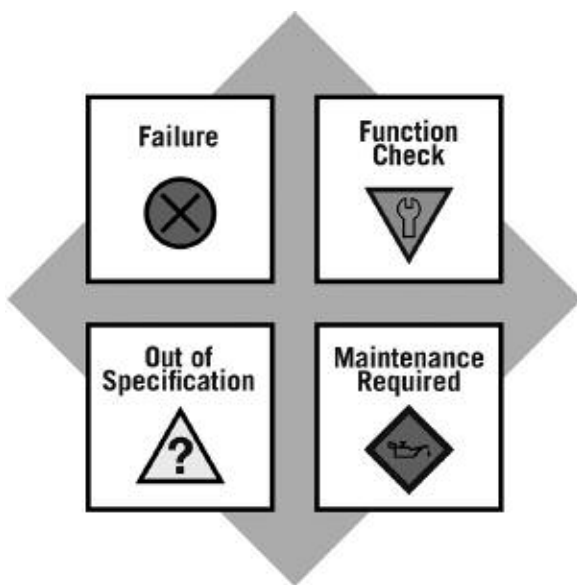

In essence, this approach ensures that the correct diagnostic information is available to the correct person-at the correct time. In addition, it allows diagnostics to be applied, as most appropriate, for a particular plant application (such as process control engineering or asset management maintenance). Customer specific mapping of diagnostics to these categories allows for flexible configuration depending on the user's requirements.

From an external Model R96 transmitter perspective, diagnostic information includes measurement of process conditions, in addition to detection of internal device or system anomalies.

As mentioned above, the indicators can be assignable (via the DTM or host system) by the user to any (or none) of the NAMUR recommended Status Signal categories: Failure, Function Check, Out of Specification, and Maintenance Required.

The FOUNDATION fieldbus version of the Model R96 transmitter was implemented according to the Field Diagnostics Profile, which is consistent with the objectives of NE 107.

In the FOUNDATION fieldbus version, diagnostic indicators can be mapped to multiple categories, an example is shown in the diagram at left.

In this example, “Calibration Required” is mapped to both the Out of Specification and Maintenance Required status signals, and the diagnostic indicator named “High Electronic Temperature” is mapped to none of the signals.

Indicators that are mapped to the Failure category will normally result in a bad status indication.

A default mapping of all diagnostic indicators will be applied initially, and can be re-applied through use of a restart with defaults operation.

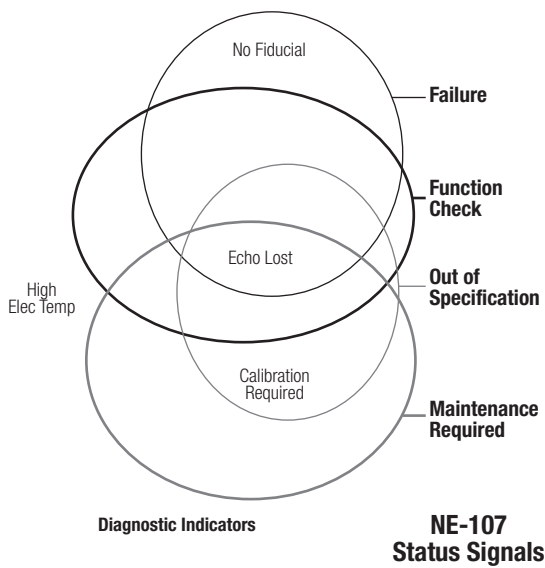

Refer to the table below for a complete listing of the Model R96 diagnostic indicators, along with their explanations, default categories, and recommended remedies.

- NOTES:
- 1) The remedies shown in this table can also be seen on the transmitter LCD by viewing the present status screen when the device is in a diagnostic condition.
 - 2) Those indicators showing failure as the default result in an alarm condition.

5.1.2 Diagnostic Indication Simulation

The DD and DTM allow for the ability to manipulate diagnostic indicators mapped to NE-107 alarm categories in Resource Block. Intended as a means to verify the configuration of the diagnostic parameters and connected equipment, a user can manually change any indicator in the Resource Block to and from the active state.

5.1.3 Diagnostic Indicator Table

Below is a listing of the Model R96 diagnostic indicators, showing their priority, explanations and recommended remedies. (Priority 1 is highest priority.)

Priority	Indicator Name	Default Category	Explanation	Remedy (Context Sensitive Help)
1	Software Error	Failure	Unrecoverable error occurred in stored program.	Contact MAGNETROL Technical Support.
2	RAM Error	Failure	RAM (read/write) memory failing.	
3	ADC Error	Failure	Analog-to-digital converter failing.	
4	EEPROM Error	Failure	Non-volatile parameter storage failing.	
5	Analog Board Error	Failure	Unrecoverable hardware failure.	
6	Spare Indicator 11	OK	Reserved for future use.	
7	Spare Indicator 1	OK	Reserved for future use.	
8	Default Parameters	Failure	All saved parameters are set to default values.	Perform complete Device Setup.
9	Spare Indicator 2	OK	Reserved for future use.	

Priority	Indicator Name	Default Category	Explanation	Remedy
10	Spare Indicator 3	OK	Reserved for future use.	
11	No Fiducial	Failure	The fiducial pulse is not located where expected, or the fiducial amplitude is not in the expected range.	Increase Fid Gain. Adjust Window to obtain Fid Ticks of 100-400.
12	Too Many Echoes	Failure	Excessive number of possible echoes detected.	Check settings: Dielectric Range Sensitivity Polarization Direction View Echo Curve.
13	Safety Zone Alarm	Failure	Risk of echo loss if liquid rises above Top Blocking Distance.	Ensure that liquid cannot reach Blocking Distance.
14	Echo Lost	Failure	No detectable level signal identified within the configured range.	Check settings: Dielectric Range Sensitivity Tank Height View Echo Curve.
15	Spare Indicator 4	OK	Reserved for future use.	
16	Spare Indicator 12	OK	Reserved for future use.	
17	High Volume Alarm	Failure	Volume calculated from Level reading exceeds capacity of vessel or custom table.	Check settings: Vessel Dimensions, Custom Table entries
18	Spare Indicator 5	OK	Reserved for future use.	
19	Initializing	Function Check	Distance measurement is inaccurate while internal filters are settling.	Wait for up to 10 seconds.
20	TB Config Changed	Function Check	A parameter has been modified from the User Interface.	If desired, reset Config Changed indicator in ADVANCED CONFIG.
21	Spare Indicator 6	OK	Reserved for future use.	
22	Ramp Slope Error	Out of Spec	Internal signal timing out of limits causing inaccurate distance measurement.	Check accuracy of Distance. Replace transmitter electronics.
23	High Elec Temp	Out of Spec	Electronics too hot. May compromise Distance measurement or damage instrument.	Shield transmitter from heat source or increase air circulation.
24	Low Elec Temp	Out of Spec	Electronics too cold. May compromise Distance measurement or damage instrument.	Insulate transmitter or locate remotely in a warmer area.

5.1.3 Diagnostic Indicator Table



Priority	Indicator Name	Default Category	Explanation	Remedy
25	Calibration Required	Out of Spec	Factory calibration has been lost. Measurement accuracy is diminished.	Return transmitter to factory for recalibration.
26	Reject Curve Invalid	Out of Spec	Echo Rejection invalid. May report erroneous Level readings.	Save a fresh Echo Rejection Curve.
27	Spare Indicator 7	OK	Reserved for future use.	
28	Inferred Level	Out of Spec	The target has been lost within the Max Distance Jump distance from the Top or Bottom Blocking Distance locations. As a result, the transmitter has inferred that the level has moved into one of those blocking regions, and will report level measurement corresponding to full or empty along with the Inferred Level diagnostic.	Verify level reading. If incorrect the configuration may need to be adjusted. Contact MAGNETROL Technical Support.
29	Spare Indicator 13	OK	Reserved for future use.	
30	Spare Indicator 14	OK	Reserved for future use.	
31	Spare Indicator 8	OK	Reserved for future use.	
32	Max Jump Exceeded	Maintenance Required	A potential valid level target has been detected which is further away from the last known valid level target than the "Max Distance Jump" parameter value derived from the selected rate of change.	Check settings: Dielectric Range Sensitivity View Echo Curve.
33	Low Echo Margin	Maintenance Required	Target echo has low Echo Margin rating.	Check settings: Dielectric Range Sensitivity View Echo Curve.
34	High Surface Velocity	Maintenance Required	The measured Surface Velocity is greater than the Max Surface Velocity value derived from the rate of change parameter.	Confirm actual tank rate of change. Adjust (increase) Rate of Change parameter accordingly.
35	Spare Indicator 9	OK	Reserved for future use.	
36	Spare Indicator 10	OK	Reserved for future use.	
37	Sequence Record	OK	A Sequence Record number has been stored in Event Log.	If desired, report Sequence Record number to MAGNETROL Technical Support.

The PULSAR Model R96 offers the ability to do Trending and Echo Curve analysis via the local graphical LCD or by using PACTware and the Model R96 DTM. The Model R96 DTM is an advanced troubleshooting tool that can aid in the resolution of some of the Diagnostic Indicators shown above.

5.1.4 Diagnostic Help

Selecting **DIAGNOSTICS** from the **MAIN MENU** presents a list of five **ITEMS** from the top level of the **DIAGNOSTICS** tree.

When **Present Status** is highlighted, the highest **MAGNETROL** priority active diagnostic indicator (numerically lowest in Table 5.1.3) is displayed on the bottom LCD line as shown above. Pressing the **ENTER** key moves the active diagnostic indicator to the top line outdented and presents in the lower area of the LCD a brief explanation of and possible remedies for the indicated condition. A blank line separates the explanation from the remedies. Additional active diagnostic indicators, if any, appear with their explanations in descending priority order. Each additional active indicator name-explanation pair is separated by a blank line from the one above.

If the explanation and remedy text (and additional name-explanation pairs) exceeds the available space, a  appears in the rightmost column of the last line indicating more text below. In this situation, the **DOWN** key scrolls the text up. Similarly, while text exists above the upper line of the text field, a  appears in the rightmost column of the top (text) line. In this situation, the **UP** key scrolls the text down. Otherwise the **DOWN** and **UP** keys are inoperative. In all cases the **ENT** or **BACK** key reverts to the previous screen.

When the transmitter is operating normally and the highlight cursor is positioned on **Present Status**, the bottom LCD line displays “**OK**” because no diagnostic indicators are active.

EVENT HISTORY – This menu displays the parameters related to diagnostic event logging.

ADVANCED DIAGNOSTICS – This menu displays parameters related to some of the advanced diagnostics available within the Model R96.

INTERNAL VALUES – Displays read-only internal parameters.

ELEC TEMPERATURES – Displays temperature information as measured in the potted module in degrees F or C.

ECHO CURVES – This menu allows the user to display the live Echo Curve and Echo Rejection on the LCD.



ECHO HISTORY SETUP – The Model R96 contains the unique and powerful feature that allows waveforms to be automatically captured based on Diagnostic Events, Time or both. This menu contains those parameters that configure that feature.

Eleven waveforms can be saved directly into the transmitter.

- Nine Troubleshooting Curves
- One Echo Rejection Curve
- One Reference Curve

TREND DATA – A 15-minute trend of the PV can be displayed on the LCD.

5.2 Diagnostic Parameters

Each detected diagnostic condition potentially affects the status of one or more of the Transducer Block output parameters.

The Process Variable Status is described by three characteristics—Quality, Sub-status and Limit.

The following table assigns the proposed values of these characteristics, in order of decreasing priority, for each of the diagnostic conditions and/or device configurations.

- NOTES:
- 1) Only the highest priority status will be indicated for a given process variable.
 - 2) If a process variable is not listed for a given diagnostic condition and/or device configuration, the status of that process variable is not affected and will be shown as Good::Non-specific: Not limited

Diagnostic/Condition	Process Variables	Quality	Sub-status	Limit
Level TB -> OOS	Level Distance Echo Strength Elec Temperature Echo Margin	Bad	Out of Service	Not limited
Vol TB -> OOS	Volume	Bad	Out of Service	Not limited
Analog Board Error	All PVs except Elec Temperature	Bad	Sensor Failure	Constant limited
Software Error	All PVs	Bad	Device Failure	Constant limited
RAM Error	All PVs	Bad	Device Failure	Constant limited

Diagnostic/Condition	Process Variables	Quality	Sub-status	Limit
ADC Failure	All PVs	Bad	Device Failure	Constant limited
EEPROM Error	All PVs	Bad	Device Failure	Constant limited
No Fiducial	All PVs except Elec Temperature	Bad	Device Failure	Constant limited
Too Many Echoes	All PVs except Elec Temperature	Bad	Device Failure	Constant limited
Echo Lost	All PVs except Elec Temperature	Bad	Device Failure	Constant limited
Inferred Level	Echo Strength Echo Margin	Bad	Device Failure	Constant limited
Default Parameters	ALL PVs	Bad	Config Error	Not limited
MeasType != Volume & Level	Volume	Bad	Config Error	Constant limited
High Volume Alarm	Volume	Bad	Config Error	High limited
Safety Zone Alarm	Level, Distance, Volume	Bad	Non-Specific	Not limited
Initializing	All PVs except Elec Temperature	Uncertain	Initial Value	Constant limited
Ramp Slope Error	All PVs	Good	Non-specific	Not limited
High Elec Temp	All PVs	Good	Non-specific	Not limited
Low Elec Temp	All PVs	Good	Non-specific	Not limited
Calibration Req'd	All PVs	Good	Non-specific	Not limited
Reject Curve Invalid	All PVs	Good	Non-specific	Not limited
Max Jump Exceeded	All PVs	Good	Non-specific	Not limited
Low Echo Margin	All PVs	Good	Non-specific	Not limited
High Surface Velocity	All PVs	Good	Non-specific	Not limited
TB Config Changed	All PVs	Good	Non-specific	Not limited
Sequence Record	All PVs	Good	Non-specific	Not limited.

5.3 FOUNDATION fieldbus Segment Checklist

There can be several reasons for a FOUNDATION fieldbus™ installation to be in a faulty condition. In order to ensure that communication can be established, the following requirements must be met.

- Device supply voltage must be higher than 9 VDC with a maximum of 32 VDC.
- Total current draw of a given segment cannot exceed the rating shown on the power conditioner and/or barrier.
- Two 100 Ω, 1 μF terminators must be connected to the network—one at each end of the segment.
- Cable length plus spur length must not exceed the following values:

Number of Spurs	1 Device	2 Devices	3 Devices	4 Devices
25–32	—	—	—	—
19–24	100 ft. (30 m)	—	—	—
15–18	200 ft. (60 m)	100 ft. (30 m)	—	—
13–14	300 ft. (90 m)	200 ft. (60 m)	100 ft. (30 m)	—
1–12	400 ft. (120 m)	300 ft. (90 m)	200 ft. (60 m)	100 ft. (30 m)

Pair	Shield	Twisted	Size	Length	Type
Single	Yes	Yes	AWG 18 (0.8 mm ²)	6,200 ft. (1,900 m)	A
Multi	Yes	Yes	AWG 22 (0.32 mm ²)	3,900 ft. (1,200 m)	B
Multi	No	Yes	AWG 26 (0.13 mm ²)	1,300 ft. (400 m)	C
Multi	Yes	No	AWG 16 (1.25 mm ²)	650 ft. (200 m)	D

- The cable shield is to be hard grounded only at one point close to the DCS. In addition, the cable shield can be capacitively grounded in multiple places to improve EMC protection.
- Ensure all devices are on the “live list,” and the schedule has been downloaded.
- Ensure that the Resource Block, then the Transducer Block, and lastly the Function Block(s) being used are in “Auto” mode rather than Out of Service (OOS).

If all of these requirements are met, stable communication should be established.

6.0 Reference Information

6.1 Agency Approvals



These units are in compliance with the EMC-directive 2014/30/EU, the PED-directive 97/23/EC and the ATEX directive 2014/34/EU.
IEC 60079-0: 2001 IEC 60079-15: 2010 IEC 60079-26: 2006

6.1.1 Agency Approvals Chart

<p>Explosion Proof US/Canada: Class I, Div 1, Group B, C, D, T4 Class I, Zone 1 A Ex db ia IIB+H2 T4 Class I, Zone 1 Ex d ia IIB+H2 T4 Ta = -40° C to +70° C Type 4X, IP67</p> <p>Flame Proof ATEX – FM14ATEX0058X II 1/2 G Ex db ia IIB + H2 T4... T1 Ga/Gb Ta = -40° C to +70° C IP67</p> <p>IEC- IECEx FMG 15.0034X Ex db ia IIB + H2 T4...T1 Ga/Gb Ta = -40° C to +70° C IP67</p>	<p>Non- Incendive US/Canada: Class I, II, III, Div 2, Group A, B, C, D, E, F, G, T4 Class 1, Zone 2 AEx nA ia IIC T4 Class 1, Zone 2 Ex nA ia IIC T4 Ta = -40° C to +70° C Type 4X, IP67</p> <p>ATEX - FM14ATEX0059X: II 3 G Ex nA IIC Gc T4 Ta = -15° C to +70° C IP67</p> <p>IEC – IECEx FMG 15.0034X Ex nA IIC Gc T6 Ta = -15° C to + 70° C IP67</p>
<p>Intrinsically Safe US/Canada: Class I, II, III, Div 1, Group A, B, C, D, E, F, G, T4 Class I, Zone 0 AEx ia IIC T4 Class I, Zone 0 Ex ia IIC T4 Ga Ta = -40° C to + 70° C Type 4X, IP67</p> <p>ATEX – FM14ATEX0058X: II 1 G Ex ia IIC T4 Ga Ta = -40° C to +70° C IP67</p> <p>IEC – IECEx FMG 15.0034X: Ex ia IIC T4 Ga Ta = -40° C to +70° C IP67</p>	<p>Dust Ignition Proof US/Canada: Class II, III, Div 1, Group E, F, and G, T5 Ta = -15° C to +70° C Type 4X, IP67</p> <p>ATEX – FM14ATEX0058X: II 2 D Ex ia tb IIIC T100° C Db Ta = -15° C to +70° C IP67</p> <p>IEC – IECEx FMG 15.0034X: Ex ia tb IIIC 100° C Db Ex ia tb IIIC T85° C to T450° C Da Ta = -15° C to +70° C IP67</p>

FM3600:2011, FM3610:2010, FM3611:2004, FM3615:2006, FM3616:2011, FM3810:2005, ANSI/ISA60079-0:2013, ANSI/ISA 60079-1:2015, ANSI/ISA 60079-11:2013, ANSI/ISA 60079-15:2012, ANSI/ISA 60079-26:2011, NEMA 250:2003, ANSI/IEC 60529:2004, C22.2 No. 0.4:2009, C22.2 No. 0.5:2008, C22.2 No. 30:2007, C22.2 No. 94:2001, C22.2 No. 213:2012, C22.2 No. 1010.1:2009, CAN/CSA 60079-0:2011, CAN/CSA 60079-1:2011, CAN/CSA 60079-11:2014, CAN/CSA 60079-15:2012, C22.2 No. 60529:2005, EN60079-0:2012, EN60079-1:2014, EN60079-11:2012, EN60079-15:2010, EN60079-26:2007, EN60079-31:2009, EN60529+A1:1991-2000, IEC60079-0:2011, IEC60079-1:2014, IEC60079-11:2011, IEC60079-15:2010, IEC60079-26:2006, IEC60079-31:2008

“This equipment with chargeable non-conductive parts, e.g. enclosure’s paint and antenna use PTFE, Co-polymer Polypropylene or Noryl En265, is provided with a warning label referring to the safety measures that must be taken if there is electrostatic charging during operation. For use in hazardous area, the equipment and side to be installed, e.g. tank, must be connected to earth and be attention to not only the measuring object, e.g. liquids, gases, powders and etc., but also the related conditions, e.g. tank container, vessel and etc. (According to IEC 60079- 32-1).”

FCC (ID# LPN-R96) Compliance Statement:

This equipment has been tested and found to comply with the limits for a Class B digital device, pursuant to part 15 of the FCC Rules. These limits are designed to provide reasonable protection against harmful interference in a residential installation. This equipment generates, uses and can radiate radio frequency energy and, if not installed and used in accordance with the instructions, may cause harmful interference to radio communications.

Telecommunications Approvals

Agency	In-Tank	Out of Tank
FCC	47 CFR, Part 15, Subpart C, Section 15.209 Unintentional Radiators	47 CFR, Part 15, Subpart C, Section 15.256
ISED	RSS-211	RSS-211

6.1.2 Agency Specifications – Explosion Proof Installation

Factory Sealed: This product has been approved by Factory Mutual Research (FM) and Canadian Standards Association (CSA) as a **Factory Sealed** device.

NOTE: Factory Sealed: No Explosion Proof conduit fitting (EY seal) is required within 18" of the transmitter. However, an Explosion Proof conduit fitting (EY seal) is required between the hazardous and safe areas.

6.1.3 Agency Specifications – Intrinsically Safe FOUNDATION Fieldbus™ Installation

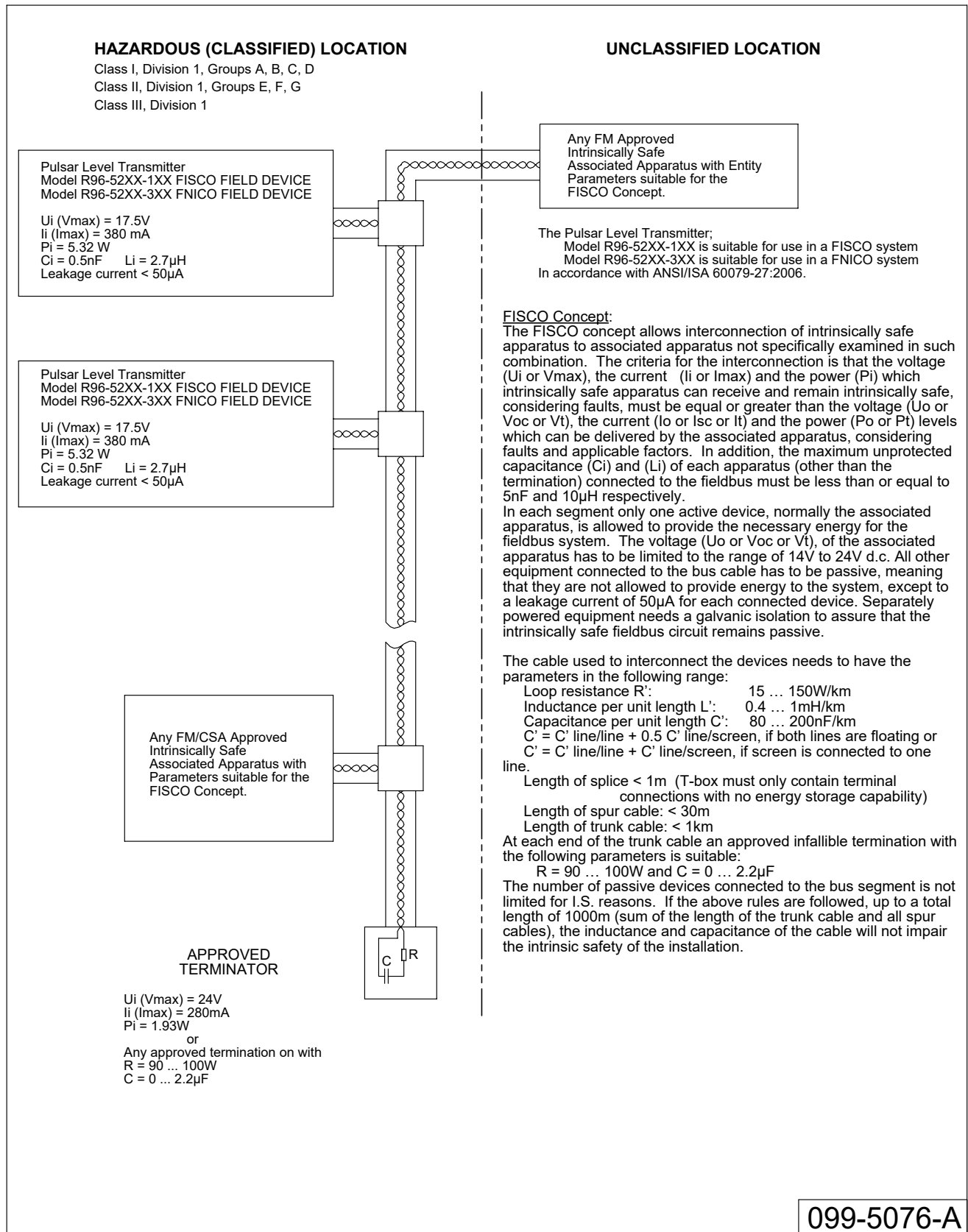

6.2 Specifications

6.2.1 Functional – Transmitter

System Design

Measurement Principle	Pulse burst radar 6 GHz
-----------------------	-------------------------

Input

Measured Variable	Level, determined by the time-of-flight of radar pulse reflections
Span	0.5 to 130 feet (0.2 to 40 meters)

Output

Type	FOUNDATION fieldbus™: H1 (ITK Ver. 6.1.2)
Range	Digital Display 1 mm
Resolution	Digital 0.1"
Diagnostic Indication	Meets requirements of NAMUR NE107

User Interface

Keypad	4-button menu-driven data entry
Display	Graphic Liquid Crystal Display
Digital Communication	FOUNDATION fieldbus™, AMS, or FDT DTM (PACTware™), EDDL
Menu Languages	Transmitter LCD: English, French, German, Spanish, Russian FOUNDATION fieldbus Host System: English

Power (Measured at instrument terminals)

FOUNDATION fieldbus™: 9 to 17.5 VDC FISCO, FNICO, Explosion Proof, General Purpose and Weather Proof

Housing

Material	IP67/die-cast aluminum A413 (<0.6% copper); optional stainless steel
Net/Gross Weight	Aluminum: 4.5 lbs. (2.0 kg) Stainless Steel: 10.0 lbs. (4.50 kg)
Overall Dimensions	H 8.34" (212 mm) x W 4.03" (102 mm) x D 7.56" (192 mm)
Cable Entry	½" NPT or M20

6.3 Model Number

6.3.1 Transmitter

1 | BASIC MODEL NUMBER AND OPERATING FREQUENCY

R96	Through-Air Radar Level Transmitter- 6 GHz Pulse Radar
-----	--

4 | POWER

5	24 VDC, Two-wire
---	------------------

5 | SIGNAL OUTPUT

1	4-20 mA with HART
2	FOUNDATION fieldbus

6 | SAFETY OPTIONS

0	None (FOUNDATION fieldbus only) (5th digit = 2)
1	SIL 2 Hardware - HART only (5th digit = 1)

7 | ACCESSORIES

0	No Digital Display and Keypad
A	Digital Display and Keypad

8 | CLASSIFICATION

0	General Purpose, Weatherproof (IP 67)
1	Intrinsically Safe (FM & CSA CL 1 Div 1, Grps A, B, C, D) (5th digit = 1 or 2)
3	Explosion-proof (FM & CSA CL 1 Div 1, Grps B, C, D)
A	Intrinsically Safe (ATEX/IEC Ex ia IIC T4) (5th digit = 1 or 2)
B	Flame-proof (ATEX/IEC Ex d ia IIC T6) (5th digit = 1 or 2)
C	Non-sparking (ATEX Ex n IIC T6) (5th digit = 1 or 2)

9 | HOUSING/CONDUIT CONNECTION

1	Die-cast Aluminum, Dual-compartment, 45-degree
2	Investment Cast, Stainless Steel, Dual-compartment, 45-degree

10 | CONDUIT CONNECTION

0	½" NPT
1	M20
2	½" NPT with sunshade
3	M20 with sunshade

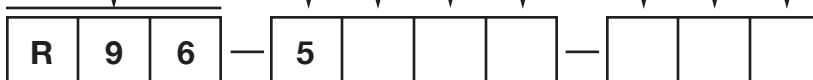

6.3 Model Number

6.3.2 Antenna — Dielectric Rod

TECHNOLOGY / OPERATING FREQUENCY

R A	PULSAR radar antennas / 6 GHz
-----	-------------------------------

CONFIGURATION / STYLE

A	TFE (Material of Construction codes A, B, C, and K only)
B	Polypropylene (Material of Construction codes A, G, K, and L only)

MATERIAL OF CONSTRUCTION

A	316/316L stainless steel
B	Hastelloy® C
K	316/316L SS; ASME B31.1 and B31.3 (meets CRN specifications)

PROCESS CONNECTION - SIZE/TYPE

31	1½" NPT thread	32	1½" BSP (G 1½) thread
43	2" 150# ANSI raised face flange	DA	DN 50, PN 16 EN 1092-1 TYPE A
44	2" 300# ANSI raised face flange	DB	DN 50, PN 25/40 EN 1092-1 TYPE A
45	2" 600# ANSI raised face flange	DD	DN 50, PN 63 EN 1092-1 TYPE A
53	3" 150# ANSI raised face flange	EA	DN 80, PN 16 EN 1092-1 TYPE A
54	3" 300# ANSI raised face flange	EB	DN 80, PN 25/40 EN 1092-1 TYPE A
55	3" 600# ANSI raised face flange	ED	DN 80, PN 63 EN 1092-1 TYPE A
63	4" 150# ANSI raised face flange	FA	DN 100, PN 16 EN 1092-1 TYPE A
64	4" 300# ANSI raised face flange	FB	DN 100, PN 25/40 EN 1092-1 TYPE A
65	4" 600# ANSI raised face flange	FD	DN 100, PN 63 EN 1092-1 TYPE A
73	6" 150# ANSI raised face flange	GA	DN 150, PN 16 EN 1092-1 TYPE A
74	6" 300# ANSI raised face flange	GB	DN 150, PN 25/40 EN 1092-1 TYPE A
75	6" 600# ANSI raised face flange	GD	DN 150, PN 63 EN 1092-1 TYPE A

O-RINGS

0	Viton® GFLT
---	-------------

ANTENNA EXTENSION

0	For nozzle height ≤ 1" (25 mm) (For threaded process connection only)
1	For nozzle height ≤ 4" (100 mm)
2	For nozzle height ≤ 8" (200 mm) (ESP designation for TFE rod only)
3	For nozzle height ≤ 12" (300 mm)

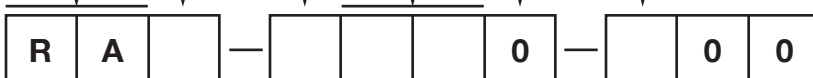

6.3 Model Number

6.3.3 Antenna – Horn

TECHNOLOGY / OPERATING FREQUENCY

R A	PULSAR radar antennas / 6 GHz
-----	-------------------------------

CONFIGURATION / STYLE

3	3" horn (for Standpipe/Stillwell use only; Materials of Construction codes A & K only)
4	4" horn
6	6" horn

MATERIAL OF CONSTRUCTION

A	316/316L stainless steel
B	Hastelloy C
K	316/316L SS; ASME B31.1 and ASME B31.3 (meets CRN specifications)

PROCESS CONNECTION - SIZE/TYPE (metal flanges welded to antenna)

53	3" 150# ANSI raised face flange	EA	DN 80, PN 16	EN 1092-1 TYPE A
54	3" 300# ANSI raised face flange	EB	DN 80, PN 25/40	EN 1092-1 TYPE A
55	3" 600# ANSI raised face flange	ED	DN 80, PN 63	EN 1092-1 TYPE A
63	4" 150# ANSI raised face flange	FA	DN 100, PN 16	EN 1092-1 TYPE A
64	4" 300# ANSI raised face flange	FB	DN 100, PN 25/40	EN 1092-1 TYPE A
65	4" 600# ANSI raised face flange	FD	DN 100, PN 63	EN 1092-1 TYPE A
73	6" 150# ANSI raised face flange	GA	DN 150, PN 16	EN 1092-1 TYPE A
74	6" 300# ANSI raised face flange	GB	DN 150, PN 25/40	EN 1092-1 TYPE A
75	6" 600# ANSI raised face flange	GD	DN 150, PN 63	EN 1092-1 TYPE A

O-RINGS

0	Viton® GFLT
1	EPDM
2	Kalrez® 4079
8	Simriz SZ485 (formerly Aegis PF128)

ANTENNA EXTENSION

1	For nozzle height ≤ 4" (100 mm)
2	For nozzle height ≤ 8" (200 mm) (ESP designation for TFE rod only)
3	For nozzle height ≤ 12" (300 mm)

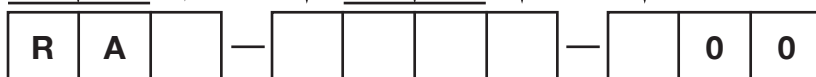

OPTIONAL FLANGES (for use with Antenna Extension Codes 1–3 only)

Part Number:	2"		3"		4"		6"	
04-6852	150#	300#	150#	300#	150#	300#	150#	300#
316L Stainless Steel	-001	-005	-002	-006	-003	-007	-004	-008
304L Stainless Steel	-009	-013	-010	-014	-011	-015	-012	-016
Carbon Steel	-017	-021	-018	-022	-019	-023	-020	-024
Hastelloy C	-025	-029	-026	-030	-027	-031	-028	-032

Part Number:	2"		3"		4"		6"	
04-6852	150#	300#	150#	300#	150#	300#	150#	300#
Kynar	-041	-045	-042	-046	-043	-047	-044	-048
PVC	-049	-053	-050	-054	-051	-055	-052	-056
Polypropylene	-057	-061	-058	-062	-059	-063	-060	-064
TFE	-065	-069	-066	-070	-067	-071	-068	-072

6.4 Parts

6.4.1 Replacement Parts

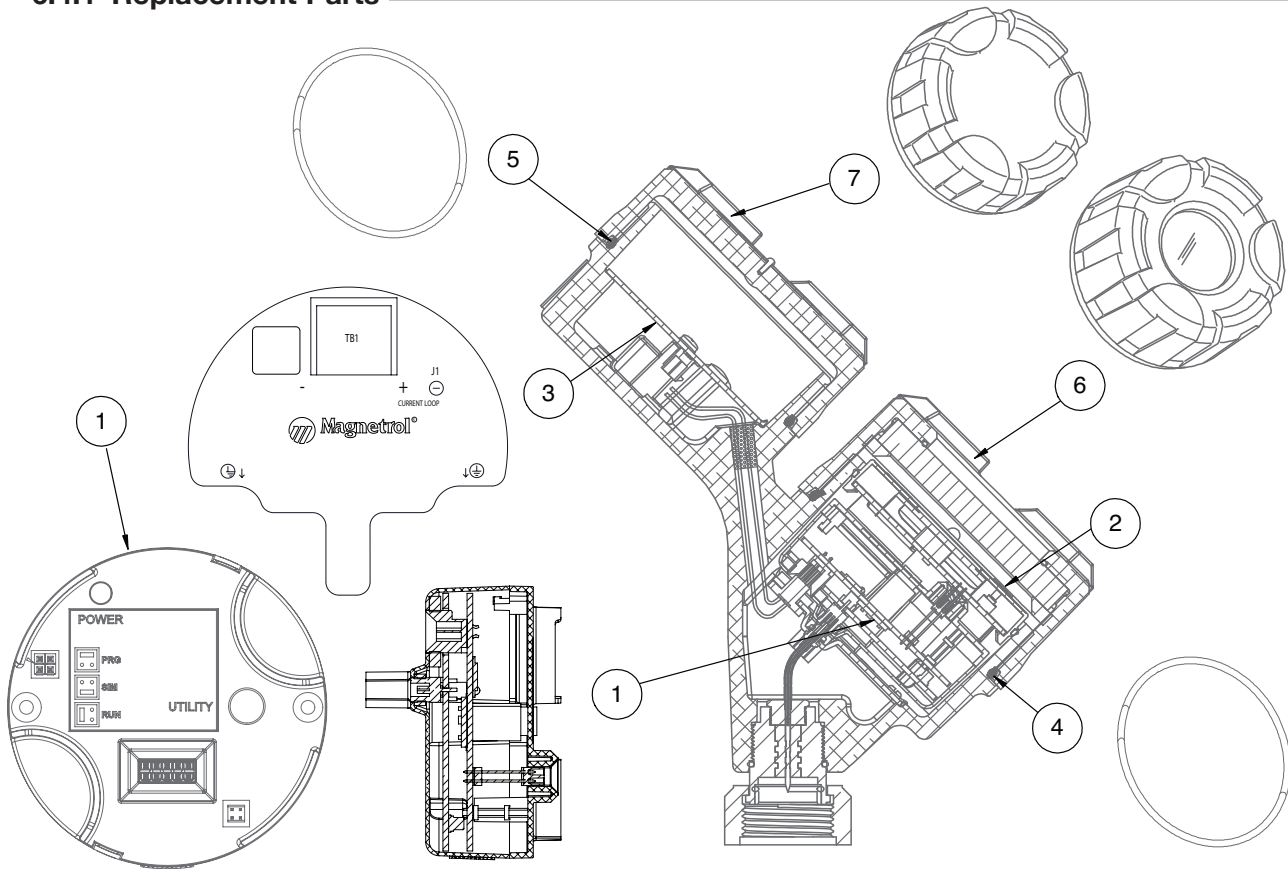

Electronics:

Digit: 1 2 3 4 5 6 7 8 9 10
 Part Number:

→ X = product with a non-standard customer requirement

Serial Number:

See nameplate, always provide complete part number and serial number when ordering spares.

(1) Electronic Module		
Digit 5	Digit 6	Replacement Part
1	1	Z31-2890-001
2	0	Z31-2890-002

(2) Display Module		
Digit 5	Digit 7	Replacement Part
1 or 2	0, 1 or 2	N/A
	A, B or C	Z31-2850-001

(3) Wiring PC Board		
Digit 5	Digit 6	Replacement Part
1	1	Z30-9165-001
2	0	Z30-9166-001

	Replacement Part
(4) "O"-ring	012-2201-237
(5) "O"-ring	012-2201-237

(6) Housing Cover			
Digit 7	Digit 8	Digit 9	Replacement Part
0, 1 or 2	all	1	004-9225-002
		2	004-9225-003
A, B or C	0, 1 or A	1	036-4413-005
	3		036-4413-001
	B, C or D	2	036-4413-001
	0, 1, 3 or A		036-4413-002
B, C or D		036-4413-002	

(7) Housing Cover	
Digit 9	Replacement Part
1	004-9225-002
2	004-9225-003

Appendix A

Level Transducer Block Table

Item	Parameter Name	Parameter Label
0	BLOCK_STRUCTURE	BLOCK STRUCT
1	ST_REV	Static Revision
2	TAG_DESC	Tag Description
3	STRATEGY	Strategy
4	ALERT_KEY	Alert Key
5	MODE_BLK	Block Mode
6	BLOCK_ERR	Block Error
7	UPDATE_EVT	Update Event
8	BLOCK_ALM	Block Alarm
9	TRANSDUCER_DIRECTORY	Transducer Directory
10	TRANSDUCER_TYPE	Transducer Type
11	XD_ERROR	Transducer Error
12	COLLECTION_DIRECTORY	Collection Directory
13	MEASUREMENT_TYPE	Measurement Type
14	LEVEL	Level
15	LEVEL_UNIT	Level Unit
16	DISTANCE	Distance
17	DISTANCE_UNIT	Distance Unit
18	ANTENNA_MODEL	Antenna Model
19	ANTENNA_EXTENSION	Antenna Extension
20	ANTENNA_MOUNT	Antenna Mount
21	TANK_HEIGHT	Tank Height
22	STILLWELL_ID	Stillwell ID
23	DIELECTRIC_RANGE	Dielectric Range
24	TURBULENCE	Turbulence
25	FOAM	Foam
26	RATE_OF_CHANGE	Rate Of Change
27	ECHO_REJECT_STATE	Echo Reject State
28	ECHO_LIST_MODE	Echo List Mode
29	SAVED_REJECT_LOCATION	Saved Reject Location
30	NEW_REJECT_LOCATION	New Reject Location
31	ECHO_REJECT_MATURITY	Echo Reject Maturity
32	ECHO_REJECT_RESPONSE	Echo Reject Response
33	SENSITIVITY	Sensitivity
34	TOP_BLOCKING_DISTANCE	Top Blocking Distance

35	BOTTOM_BLOCKING_DISTANCE	Bottom Blocking Distance
36	SAFETY_ZONE_ALARM	Safety Zone Alarm
37	SAFETY_ZONE_HEIGHT	Safety Zone Height
38	RESET_SAFETY_ZONE_LATCH	Reset SZ Latch
39	ECHO_LOSS_DELAY	Echo Loss Delay
40	ALARM_DELAY	Failure Alarm Delay
41	LEVEL_TRIM	Level Trim
42	TARGET_ALGORITHM	Target Algorithm
43	TARGET_THRESH_MODE	Target Threshold Mode
44	TARG_AUTO_THRESH_VALUE	Target Auto Threshold Value
45	TARG_FIXED_THRESH_VALUE	Target Fixed Threshold Value
46	BASE_THRESHOLD	Base Threshold
47	TVG_START_VALUE	TVG Start Value
48	TVG_END_VALUE	TVG End Value
49	TVG_START_LOCATION	TVG Start Location
50	RUN_AVERAGE_DEPTH	Run Average Depth
51	MAX_SURFACE_VELOCITY	Max Surface Velocity
52	MAX_DISTANCE_JUMP	Max Distance Jump
53	EMPTY_STATE_DELAY	Empty State Delay
54	RESET_PARAMETERS	Reset Parameters
55	FIDUCIAL_TICKS	Fiducial Ticks
56	FIDUCIAL_STRENGTH	Fiducial Strength
57	BOUNDARY_STATE	Boundary State
58	LEVEL_TICKS	Level Ticks
59	ECHO_STRENGTH	Echo Strength
60	ECHO_MARGIN	Echo Margin
61	SURFACE_VELOCITY	Surface Velocity
62	ELECTRONICS_TEMPERATURE	Electronics Temp
63	TEMPERATURE_UNIT	Temperature Unit
64	MAX_ELECTRONICS_TEMP	Max Elec Temp
65	MIN_ELECTRONICS_TEMP	Min Elec Temp
66	RESET_ELECTRONICS_TEMPS	Reset Electronic Temps
67	ENTER_PASSWORD	Enter Password
68	ELEC_TEMP_OFFSET	Elec Temp Offset
69	NAP_VALUE	NAP Value
70	FACTORY_RESET	Factory Reset
71	FIDUCIAL_GAIN	Fiducial Gain
72	WINDOW_TAR	Window

73	CONV_FACT	Conversion Factor
74	SCLE_OFFS	Scale Offset
75	TVG_DIVISOR	TVG Divisor
76	FACTORY_PARAMETER_1	Factory Parameter 1
77	FACTORY_PARAMETER_2	Factory Parameter 2
78	FACTORY_PARAMETER_3	Factory Parameter 3
79	FACTORY_PARAMETER_4	Factory Parameter 4
80	MAGNETROL_SERIAL_NUMBER	Magnetrol S/N
81	DATE_CODE	Date Code
82	CONFIG_CHANGED_MODE	TB Config Chgd Mode
83	RESET_CONFIG_CHANGED	Reset Config Changed
84	USER_PASSWORD	New User Password
85	LOCAL_DISP_MEAS_VALUES	Local Disp Meas Values
86	LOCAL_DISP_LANGUAGE	Local Disp Language
87	LOCAL_DISP_PHYS_DEV_TAG	Local Disp Phys Dev Tag
88	SOFTWARE_REV	Software Rev
89	HARDWARE_REV	Hardware Rev
90	PRESENT_STATUS	Present Status
91	STATUS_INDICATORS_1	Indicators Group 1
92	STATUS_INDICATORS_2	Indicators Group 2
93	STATUS_INDICATORS_3	Indicators Group 3
94	STATUS_INDICATORS_4	Indicators Group 4
95	STATUS_INDICATORS_5	Indicators Group 5
96	TREND_LEVEL_VALUE	Level
97	TREND_DISTANCE_VALUE	Distance
98	TREND_ECHO_STR_VALUE	Echo Strength
99	TREND_SIGNAL_MARGIN_VALUE	Signal Margin
100	DEVICE_CLOCK	Device Clock
101	HISTORY_CONTROL	History Control
102	HIST_ENTRY1	Event History 1
103	HIST_ENTRY2	Event History 2
104	HIST_ENTRY3	Event History 3
105	HIST_ENTRY4	Event History 4
106	HIST_ENTRY5	Event History 5
107	HIST_ENTRY6	Event History 6
108	HIST_ENTRY7	Event History 7
109	HIST_ENTRY8	Event History 8
110	HIST_ENTRY9	Event History 9

111	HIST_ENTRY10	Event History 10
112	RESET_HISTORY	Reset History
113	ECHO_HIST_TRIGGER_MODE	Echo Hist Trigger Mode
114	ECHO_HIST_TIME_TRIGGERS	Echo Hist Time Triggers
115	ECHO_HIST_EVENT_TRIGGERS	Echo Hist Event Triggers
116	ECHO_REJECTION_LOG	Echo Rejection
117	ECHO_REFERENCE_LOG	Echo Reference
118	ECHO_HISTORY_LOG1	Echo History 1
119	ECHO_HISTORY_LOG2	Echo History 2
120	ECHO_HISTORY_LOG3	Echo History 3
121	ECHO_HISTORY_LOG4	Echo History 4
122	ECHO_HISTORY_LOG5	Echo History 5
123	ECHO_HISTORY_LOG6	Echo History 6
124	ECHO_HISTORY_LOG7	Echo History 7
125	ECHO_HISTORY_LOG8	Echo History 8
126	ECHO_HISTORY_LOG9	Echo History 9
127	DELETE_ECHO_HISTORY	Delete Echo History
128	SAVE_ECHO_CURVE	Save Echo Curve
129	VIEW_ECHO_CURVE	View Echo Curve
130	WAVEFORM_SUMMARY	Waveform Summary
131	ECHO_CURVE_DATA	Echo Curve Data
132	ECHO_DATA_INDEX	Echo Data Index
133	DATA_LOG_SETUP	Data Log Setup
134	DATA_LOG_SUMM_READ_REQ	Log Summary Read Req
135	DATA_LOG_SUMMARY	Data Log Summary
136	DATA_LOG_INDEX	Data Log Index
137	DATA_LOG_RECORDS	Log Data
138	PD_TAG_APPL_IMAGE	PD Tag
139	ECHO_LIST_CONTROL	EchoListControl
140	ECHO_LIST_TYPE	Echo List Type
141	ECHO_LIST_LENGTH	Echo List Length
142	ECHO_LIST_ENTRY1	Echo List 1
143	ECHO_LIST_ENTRY2	Echo List 2
144	ECHO_LIST_ENTRY3	Echo List 3
145	ECHO_LIST_ENTRY4	Echo List 4
146	ECHO_LIST_ENTRY5	Echo List 5
147	ECHO_LIST_ENTRY6	Echo List 6
148	ECHO_LIST_ENTRY7	Echo List 7

149	ECHO_LIST_ENTRY8	Echo List 8
150	ECHO_LIST_ENTRY9	Echo List 9
151	ECHO_LIST_ENTRY10	Echo List 10
152	ECHO_LIST_ENTRY11	Echo List 11
153	ECHO_LIST_ENTRY12	Echo List 12
154	ECHO_LIST_ENTRY13	Echo List 13
155	ECHO_LIST_ENTRY14	Echo List 14
156	ECHO_LIST_ENTRY15	Echo List 15

Volume Transducer Block Table

Item	Parameter Name	Parameter Label
0	BLOCK_STRUCTURE	BLOCK STRUCT
1	ST_REV	Static Revision
2	TAG_DESC	Tag Description
3	STRATEGY	Strategy
4	ALERT_KEY	Alert Key
5	MODE_BLK	Block Mode
6	BLOCK_ERR	Block Error
7	UPDATE_EVT	Update Event
8	BLOCK_ALM	Block Alarm
9	TRANSDUCER_DIRECTORY	Transducer Directory
10	TRANSDUCER_TYPE	Transducer Type
11	XD_ERROR	Transducer Error
12	COLLECTION_DIRECTORY	Collection Directory
13	MEAS_TYPE	Measurement Type
14	VOLUME	Volume
15	VOLUME_UNIT	Volume Unit
16	LEVEL_VALUE	Level
17	LEVEL_UNIT	Level Unit
18	VESSEL_TYPE	Vessel Type
19	VESSEL_RADIUS	Vessel Radius
20	VESSEL_ELLIPSE_DEPTH	Vessel Ellipse Depth
21	VESSEL_CONICAL_HEIGHT	Vessel Conical Height
22	VESSEL_WIDTH	Vessel Width
23	VESSEL_LENGTH	Vessel Length
24	VESSEL_SENSOR_OFFSET	Vessel Sensor Offset
25	VOLUME_TABLE_TYPE	Volume Table Type

26	LEVEL_INPUT_SOURCE	Level Input Source
27	VOLUME_TABLE_LENGTH	Volume Table Length
28	VOLUME_TABLE_PT_01	Volume Table Pt 01
29	VOLUME_TABLE_PT_02	Volume Table Pt 02
30	VOLUME_TABLE_PT_03	Volume Table Pt 03
31	VOLUME_TABLE_PT_04	Volume Table Pt 04
32	VOLUME_TABLE_PT_05	Volume Table Pt 05
33	VOLUME_TABLE_PT_06	Volume Table Pt 06
34	VOLUME_TABLE_PT_07	Volume Table Pt 07
35	VOLUME_TABLE_PT_08	Volume Table Pt 08
36	VOLUME_TABLE_PT_09	Volume Table Pt 09
37	VOLUME_TABLE_PT_10	Volume Table Pt 10
38	VOLUME_TABLE_PT_11	Volume Table Pt 11
39	VOLUME_TABLE_PT_12	Volume Table Pt 12
40	VOLUME_TABLE_PT_13	Volume Table Pt 13
41	VOLUME_TABLE_PT_14	Volume Table Pt 14
42	VOLUME_TABLE_PT_15	Volume Table Pt 15
43	VOLUME_TABLE_PT_16	Volume Table Pt 16
44	VOLUME_TABLE_PT_17	Volume Table Pt 17
45	VOLUME_TABLE_PT_18	Volume Table Pt 18
46	VOLUME_TABLE_PT_19	Volume Table Pt 19
47	VOLUME_TABLE_PT_20	Volume Table Pt 20
48	VOLUME_TABLE_PT_21	Volume Table Pt 21
49	VOLUME_TABLE_PT_22	Volume Table Pt 22
50	VOLUME_TABLE_PT_23	Volume Table Pt 23
51	VOLUME_TABLE_PT_24	Volume Table Pt 24
52	VOLUME_TABLE_PT_25	Volume Table Pt 25
53	VOLUME_TABLE_PT_26	Volume Table Pt 26
54	VOLUME_TABLE_PT_27	Volume Table Pt 27
55	VOLUME_TABLE_PT_28	Volume Table Pt 28
56	VOLUME_TABLE_PT_29	Volume Table Pt 29
57	VOLUME_TABLE_PT_30	Volume Table Pt 30
58	VOLUME_HIGH_LIMIT	Volume High Limit
59	LEVEL_LOW_LIMIT	Level Low Limit
60	LEVEL_HIGH_LIMIT	Level High Limit
61	ENTER_PASSWORD	Enter Password
62	PRESENT_STATUS	Present Status
63	STATUS_INDICATORS_1	Indicators Group 1

64	STATUS_INDICATORS _2	Indicators Group 2
65	STATUS_INDICATORS _3	Indicators Group 3
66	STATUS_INDICATORS _4	Indicators Group 4
67	STATUS_INDICATORS _5	Indicators Group 5
68	TREND_VOLUME_VALUE	Volume

Service Policy

Owners of MAGNETROL may request the return of a control or any part of a control for complete rebuilding or replacement. They will be rebuilt or replaced promptly. Controls returned under our service policy must be returned by Prepaid transportation. Magnetrol will repair or replace the control at no cost to the purchaser (or owner) other than transportation if:

1. Returned within the warranty period; and
2. The factory inspection finds the cause of the claim to be covered under the warranty.

If the trouble is the result of conditions beyond our control; or, is NOT covered by the warranty, there will be charges for labor and the parts required to rebuild or replace the equipment.

In some cases it may be expedient to ship replacement parts; or, in extreme cases a complete new control, to replace the original equipment before it is returned. If this is desired, notify the factory of both the model and serial numbers of the control to be replaced. In such cases, credit for the materials returned will be determined on the basis of the applicability of our warranty.

No claims for misapplication, labor, direct or consequential damage will be allowed.

Return Material Procedure

So that we may efficiently process any materials that are returned, it is essential that a "Return Material Authorization" (RMA) number be obtained from the factory prior to the material's return. This is available through Magnetrol local representative or by contacting the factory. Please supply the following information:

1. Company Name
2. Description of Material
3. Serial Number
4. Reason for Return
5. Application

Any unit that was used in a process must be properly cleaned in accordance with OSHA standards, before it is returned to the factory.

A Material Safety Data Sheet (MSDS) must accompany material that was used in any media.

All shipments returned to the factory must be by prepaid transportation.

All replacements will be shipped F.O.B. factory.

PULSAR Pulse Burst Radar transmitters may be protected by one or more of the following U.S. Patent Nos.:
US 6,062,095; US 6,980,174; US 7,102,584; US 7,106,248; US 7,271,646



705 Enterprise Street • Aurora, Illinois 60504-8149 • 630.969.4000
info@magnetrol.com • magnetrol.com

Copyright © 2019 Magnetrol International, Incorporated

FOUNDATION fieldbus logo is a registered trademark of the Fieldbus Foundation
Hastelloy is a registered trademark of Haynes International, Inc.
Viton and Kalrez are registered trademarks of DuPont Performance Elastomers

BULLETIN: 58-640.2
EFFECTIVE: June 2019
SUPERCEDES: September 2016