

## Data Sheet

# ECLIPSE<sup>®</sup>

## Model 706 High Performance Guided Wave Radar Level Transmitter

### Registered Address

ABLE Instruments & Controls Ltd  
Cutbush Park, Danehill, Lower Earley,  
Reading, Berkshire, RG6 4UT. UK.

### Reading

Tel: +44 (0)118 9311188 | Email: info@able.co.uk

### Aberdeen

Tel: +44 (0)1224 725999 | Email: ab@able.co.uk

### Web

able.co.uk

### E-commerce

247able.com



Registered in England No. 01851002. VAT No. GB 417 2481 61



# Eclipse® Model 706 High Performance Guided Wave Radar Level Transmitter

## DESCRIPTION

The Eclipse® Model 706 High Performance Transmitter is a loop-powered, 24 VDC level transmitter that is based upon the proven and accepted technology of Guided Wave Radar (GWR). Encompassing a number of significant engineering accomplishments, this leading edge level transmitter is designed to provide measurement performance well beyond that of many of the more traditional technologies.

Utilizing “diode switching” technology, along with the most comprehensive probe offering on the market, this single transmitter can be used in a wide variety of applications ranging from very light hydrocarbons to water-based media.

The innovative angled, dual compartment enclosure is now a common sight in the industry. This enclosure, first brought to the industry by Magnetrol® in 1998, is angled to maximize ease of wiring, configuration, and viewing of the versatile graphic LCD display.

One universal Model 706 transmitter can be used and interchanged with all probe types, and offers enhanced reliability as it is certified for use in critical SIL 2 hardware safety loops.

The ECLIPSE Model 706 supports both the FDT/DTM and Enhanced DD (EDDL) standards, which allow viewing of valuable configuration and diagnostic information such as the echo curve in tools such as PACTware™, AMS Device Manager, and various HART® Field Communicators.

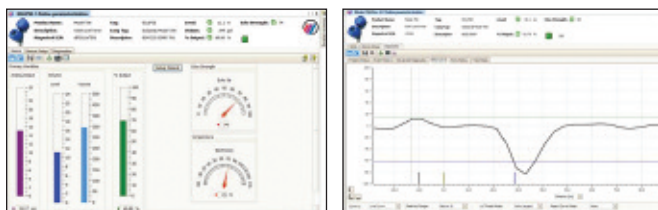

Eclipse® Model 706 DTM

## Measures Level, Interface, Volume, and Flow



## APPLICATIONS

**MEDIA:** Liquids, solids, or slurries; hydrocarbons to water-based media (Dielectric Constant  $\epsilon_r = 1.2-100$ )

**VESSELS:** Most process or storage vessels up to rated probe temperature and pressure.

**CONDITIONS:** All level measurement and control applications including process conditions exhibiting visible vapors, foam, surface agitation, bubbling or boiling, high fill/empty rates, low level and varying dielectric media or specific gravity.

# FEATURES

- Multivariable, two-wire, 24 VDC loop-powered transmitter for level, interface, volume, or flow.
- Diode switching technology offers best-in-class signal strength and signal-to-noise ratio (SNR) resulting in enhanced capability in difficult low dielectric applications.
- Level measurement not affected by changing media characteristics.
- No need to move levels for calibration.
- Overfill Capable probes allow for “true level” measurement all the way up to the process seal, without the need for special algorithms.
- 4-button keypad and graphic LCD display allow for convenient viewing of configuration parameters and echo curve.
- Proactive diagnostics advise not only what is wrong, but also offer troubleshooting tips.
- Nine common tank shapes for volumetric output.
- 30-point custom strapping table for uncommonly-shaped tanks.
- Two standard flumes and four standard weirs of various sizes for flow measurement.
- Generic flow equation for non-standard channels.
- 360° rotatable housing can be separated from probe without depressurizing the vessel.
- Probe designs up to +850 °F/6250 psi (+450 °C/431 bar).
- Saturated steam applications up to 3000 psi (207 bar), +750 °F (+400 °C) when installed in side-mounted chamber.
- Cryogenic applications down to -320 °F (-196 °C).
- Transmitter can be remote-mounted up to 12 feet (3.6 m) away from the probe.
- SIL certification allows use in SIL 2/3 Loops
- No moving parts.
- FOUNDATION fieldbus™, PROFIBUS PA and Modbus digital outputs.
- Lloyd's Register steam drum approval

# TECHNOLOGY

## PRINCIPLE OF OPERATION

ECLIPSE Guided Wave Radar is based upon the technology of TDR (Time Domain Reflectometry). TDR utilizes pulses of electromagnetic energy transmitted down a wave guide (probe). When a pulse reaches a surface that has a higher dielectric constant than the air ( $\epsilon_r = 1$ ) in which it is traveling, a portion of the pulse is reflected. The transit time of the pulse is then measured via high speed timing circuitry that provides an accurate measure of the liquid (or solids) level. The amplitude of the reflection depends on the dielectric constant of the product. The higher the dielectric constant, the larger is the reflection.

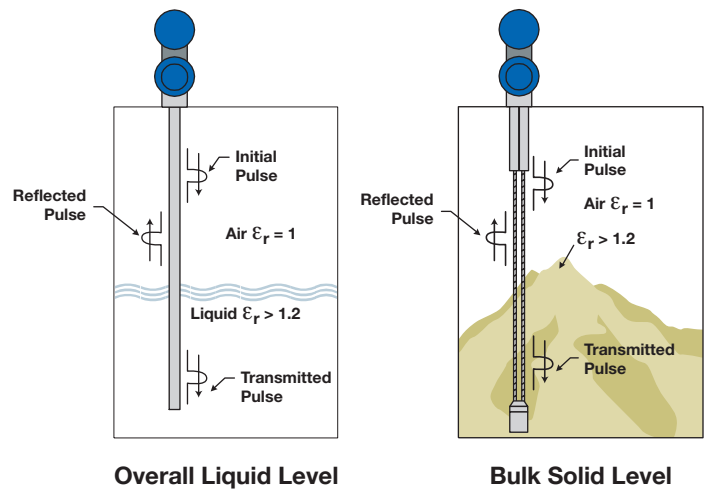

## INTERFACE MEASUREMENT

The ECLIPSE Model 706 is capable of measuring both an upper liquid level and an interface liquid level. As only a portion of the pulse is reflected from a low dielectric upper surface, some of the transmitted energy continues down the GWR probe through the upper liquid. The remaining initial pulse is again reflected when it reaches the higher dielectric lower liquid. It is required that the upper liquid has a dielectric constant less than 10, and the lower liquid has a dielectric constant greater than 15. A typical interface application would be oil over water, with the upper layer of oil being non-conductive ( $\epsilon_r \approx 2.0$ ), and the lower layer of water being very conductive ( $\epsilon_r \approx 80$ ). The thickness of the upper layer could be as small as 2" (50 mm) while the maximum upper layer is limited to the length of the GWR probe.

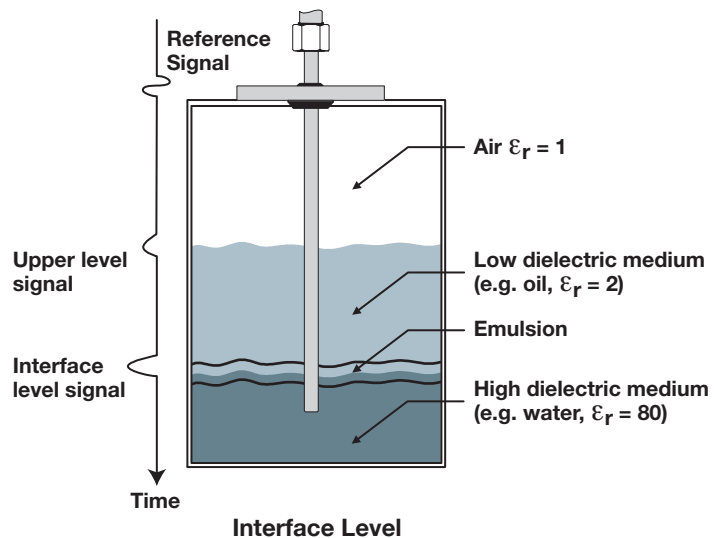

# SPECIAL APPLICATIONS

---

## EMULSION LAYERS

As emulsion layers, also called “rag layers,” can decrease the strength of the reflected signal in an interface application, GWR transmitters are typically recommended for applications that have clean, distinct layers.

However, the ECLIPSE Model 706, with its powerful internal measurement algorithms, will tend to detect the top of an emulsion layer. Contact the factory for application assistance regarding emulsion layers in your specific application.

## SATURATED STEAM APPLICATIONS (Boilers, Feedwater Heaters, etc.)

As the temperature of a saturated steam application increases, the dielectric constant of the steam vapor space also increases. This increase in vapor space dielectric causes a delay in the GWR signal propagation as it travels down the probe, causing the liquid level to appear lower than actual.

The ECLIPSE Model 706 transmitter and Model 7yS Coaxial Steam probe provide a unique solution to this application. The effects of the changing steam conditions can be compensated for by utilizing a mechanical steam target placed inside and near the top of the Model 7yS coaxial probe.

**NOTE:** The measurement error associated with this propagation delay does depend on temperature and is a function of the square root of the vapor space dielectric constant. For example, with no compensation, a +450 °F (+230 °C) application would show a level error of about 5.5%, while a +600 °F (+315 °C) application would show an error approaching 20%!

Knowing exactly where the target is located at room temperature, and then continuously monitoring its apparent location, the vapor space dielectric can be back-calculated. Knowing the vapor space dielectric, accurate compensation of the actual liquid level reading is accomplished.

This is a patented technique with two US Patents (US 6642801 and US 6867729) issued for both the mechanical target concept and the associated software algorithm.

Contact the factory for additional information relating to saturated steam applications.

In addition to vapor compensation, the standard Model 7yS Steam probe contains:

### **Only one bottom metal spacer**

This eliminates the need for any spacers along the length of the probe, removing chemical compatibility concerns.

### **A unique (patent-pending) condensation tube design**

This feature is very important in those high temperature applications where condensation can form in and around the probe, causing propagation delay issues.

### **An adjustable steam target location**

This allows optimization of the vapor compensation based on the details of a specific application.

## OVERFILL CAPABILITY

Although agencies like WHG or VLAREM certify **Overfill proof** protection, defined as the tested, reliable operation when the transmitter is used as overfill alarm, it is assumed in their analysis that the installation is designed in such a way that the vessel or side mounted cage cannot physically overfill.

However, there are practical applications where a GWR probe can be completely flooded with level all the way up to the process connection (face of the flange). Although the affected areas are application dependent, typical GWR probes have a transition zone (or possibly dead zone) at the top of the probe where interacting signals can either affect the linearity of the measurement or, more dramatically, result in a complete loss of signal.

While some manufacturers of GWR transmitters may use special algorithms to “infer” level measurement when this undesirable signal interaction occurs and the actual level signal is lost, the ECLIPSE Model 706 offers a unique solution by utilizing a concept called **Overfill Safe Operation**.

An **Overfill safe probe** is defined by the fact that it has a predictable and uniform characteristic impedance all the way down the entire length of the waveguide (probe). These probes allow the ECLIPSE Model 706 to measure accurate levels up to the process flange without any non-measurable zone at the top of the GWR probe.

**Overfill safe** GWR probes are unique to ECLIPSE GWR, and coaxial probes can be installed at any location on the vessel. Overfill safe probes are offered in a variety of Coaxial and Caged designs.

# PROBE OVERVIEW

## THREE STYLES OF GWR PROBES

With one basic ECLIPSE Model 706 transmitter that operates with all probes, choosing the proper Guided Wave Radar (GWR) probe is the most important decision in the application process. The probe configuration establishes fundamental performance characteristics.

All ECLIPSE Model 706 probes can be described by three basic configurations:

- Coaxial
- Twin flexible cable
- Single element (rigid rod or flexible cable)

### COAXIAL PROBES

The coaxial probe is the most efficient of all GWR probe configurations and should be the first consideration in all applications. Analogous to the efficiency of coaxial cable, a coaxial probe allows almost unimpeded movement of the high frequency pulses throughout its length.

The electromagnetic field that develops between the inner rod and outer tube is completely contained and uniform down the entire length of the probe. See Figure 1. This means that the coaxial probe is immune to any proximity affects from other objects in the vessel, and therefore, in essence, it can be used anywhere that it can mechanically fit.

The efficiency and overall sensitivity of a coaxial configuration yields robust signal strength, even in extremely low dielectric ( $\epsilon_r \geq 1.4$ ) applications. The sensitivity of this “closed” design, however, also makes it more susceptible to measurement error in applications that can have coating and buildup.

All ECLIPSE Model 706 coaxial probes are Overfill Safe as standard, by design.

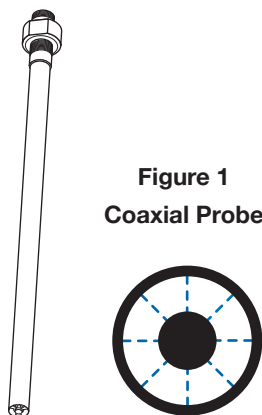

**Figure 1**  
**Coaxial Probe**

Each of these probe configurations has specific strengths and weaknesses. Although there can be overlap, and different probes can certainly be used in similar applications, it is important to understand their basic differences so that one can choose the probe type that will offer optimal performance.

The descriptions below are facts relating to the physics of GWR technology and are not specific to the ECLIPSE Model 706.

### BASIC—FOR CLEAN LIQUIDS

The basic 0.875" (22.5 mm) diameter coaxial GWR probe is only recommended for use in clean applications or special applications such as saturated steam. Teflon®, PEEK, or alumina spacers centering the inner rod within the outer tube are located at 24" (60 cm) intervals, resulting in a perfect characteristic impedance along the entire length of the probe.

This probe is recommended in applications with viscosities up to 500 cP (mPa.s) maximum.

### ENLARGED—FOR DIFFICULT LIQUIDS

The standard Enlarged 1.75" (45 mm) or 1.93" (49mm) diameter coaxial GWR probes can be generally used for most applications. They can be installed directly into the tank as well as into bypass cages, stillwells or bridles.

The robust construction reduces the number of spacers required, allowing the probe to be used in applications where higher risk of buildup exists. To further reduce the possibility of media buildup, the use of a single bottom spacer is recommended up to probe lengths of 100 inches (2.54 meters). The overall sensitivity and performance of an enlarged coaxial GWR probe is identical to a standard coaxial GWR probe, but it offers the very important advantage that it can be used in applications with viscosities up to 2,000 cP (mPa.s).

# PROBE OVERVIEW CONTINUED

## THREE STYLES OF GWR PROBES

### OPTIONAL FLUSHING CONNECTION

The maintenance of coaxial GWR probes in applications suffering from buildup or crystallization can be significantly improved by using an optional flushing connection. This flushing connection is a metal extension with a port welded above the process connection. The port allows the user to purge the inside of the coaxial GWR probe during routine maintenance.

**Note:** The best approach to eliminate the effects of condensation or crystallization is to install adequate insulation or heat tracing (steam or electrical). A flushing connection is no substitute for proper maintenance, but will help to reduce the frequency of the intervention.

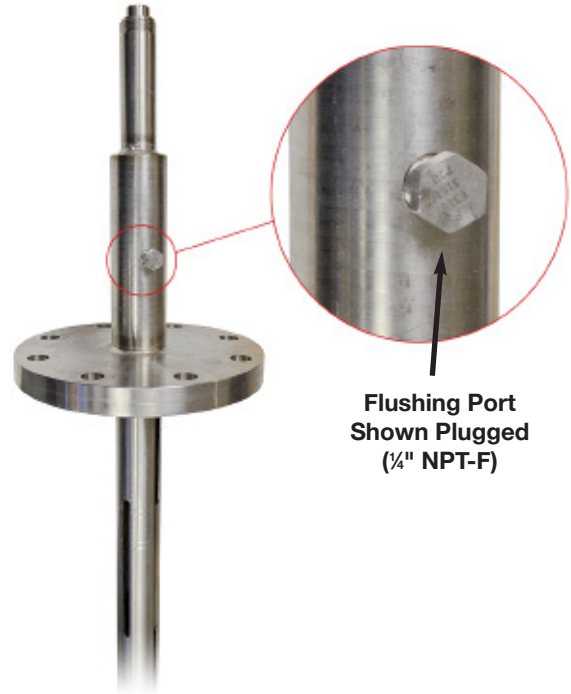

### CAGED-FOR DIRTY LIQUIDS

Unique to MAGNETROL, the Caged GWR probe is a single rod probe which uses an existing or new cage, bridle, or stillwell as the second conductor to re-create the same signal propagation as a coaxial GWR probe. Caged GWR probes are designed for 2" (DN50), 3" (DN80) or 4" (DN100) diameter metal chambers, and utilize a specially designed impedance matching section that results in the same overall characteristic impedance of a coaxial style GWR probe.

Caged GWR probes offer the same sensitivity and performance as coaxial GWR probes, but the single conductor design allows it to be used in applications with viscosities up to 10,000 cP (mPa.s).

### OPTIONAL ANNUNCIATOR FITTING

High Pressure and High Temperature High Pressure ECLIPSE Model 706 probes containing a glass ceramic alloy process seal (Models 7yD, P, J, L, M and N) are available with an optional annunciator fitting. The use of this fitting complies with the Dual Seal requirements of

ANSI/ISA-12.27.01-2011, titled "Requirements for Process Sealing between Electrical Systems and Flammable or Combustible Process Fluids," which require the incorporation of a method that indicates or annunciates a primary seal failure (e.g., visible leakage, an audible whistle, or other means of monitoring).

TWIN CABLE FLEXIBLE PROBES

The relationship of the Twin Cable probe design to a coaxial probe design is similar to that of older, twin-lead, antenna lead-in to modern, coaxial cable. 300-ohm twin-lead cable simply does not have the efficiency of 75-ohm coaxial cable, making the parallel conductor design less sensitive than the concentric coaxial. See Figure 2. This translates into Twin Cable GWR probes having the ability to measure dielectrics down to  $\epsilon_r \geq 1.7$ .

Heavy bridging of material between the cables across the FEP coating can cause improper measurement and should be avoided.

Figure 2 also shows that, although most of the electromagnetic field develops between the two cables, there is also some peripheral energy that expands outward, making the Twin Cable probe more sensitive to proximity effects of objects located immediately around it. For that reason, it is recommended to keep the active element of the Twin Cable probe at least 1 inch (25 mm) away from metal objects.

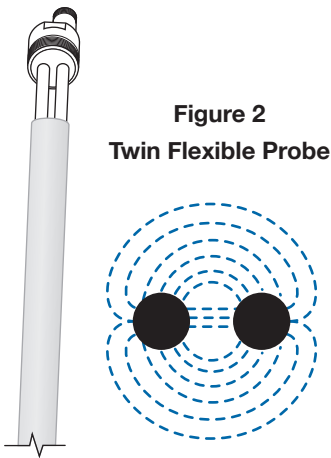

SINGLE ROD PROBES

Single element GWR probes act quite differently than both coaxial and twin cable designs. With only one conductor to work with, the pulses of energy develop between the single rod probe and the mounting nut or flange. In other words, the pulse propagates down and around the rod as it references its ground at the top of the tank.

The energy and efficiency of the pulse are directly related to how much metallic surface exists around it at the top of the vessel. This metallic surface at the top of the probe is called the “launch plate.” The larger the launch plate, the more efficient the signal propagation down the probe.

Figure 3 shows the single element design and how the electromagnetic pulse effectively expands into a teardrop shape as it propagates away from the top of the tank (the inherent ground reference). This single element configuration (rod or cable) is the least efficient of the three probe types, but can still operate with a minimum dielectric detection of approximately  $\epsilon_r > 1.7$  in an open, non-metallic vessel.

However, this dielectric constant performance improves considerably ( $\epsilon_r > 1.4$ ) when the single rod probe is installed in a metal cage/bridle, or mounted 2–6" (50–150 mm) away from a metal tank wall. Because the design is “open,” it exhibits two strong tendencies:

- It is the most forgiving of coating and buildup. (The PFA-insulated probe is the best choice for severe buildup and coating).
- It is most affected by proximity issues.

It is important to note that a parallel metal wall INCREASES the performance of a single rod probe while a singular, metal object protruding out near the probe may be improperly detected as a liquid level.

These tendencies are application/installation dependent. Therefore, by properly matching the single rod probe to a cage/chamber, the ECLIPSE Model 706 broad offering of caged probes combines the performance/sensitivity advantages of a coaxial probe and the viscosity immunity of a single rod probe. The Caged Probes are Overfill Safe by design, can be used in interface and other difficult, low dielectric applications, and are unique to MAGNETROL and the ECLIPSE Model 706.

Contact the factory for additional support and questions.

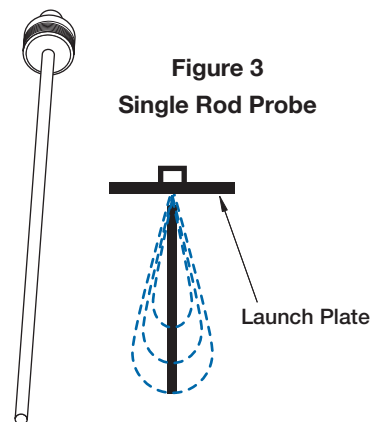

# PROBE SELECTION GUIDE

## COAXIAL/CAGED GWR PROBE

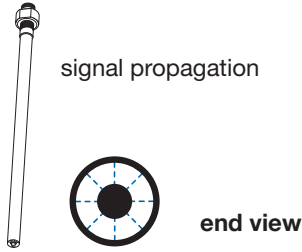

## TWIN CABLE GWR PROBE

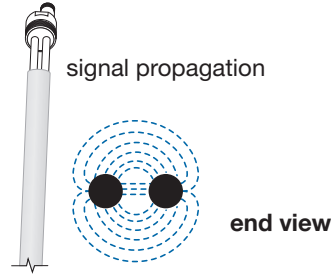

## SINGLE ROD/CABLE PROBE

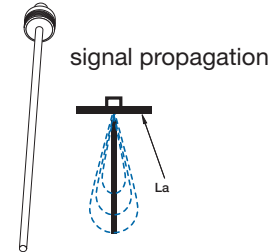

GWR Probe <sup>①</sup>	Description	Application	Installation	Dielectric Range <sup>②③</sup>	Temperature Range <sup>④</sup>	Max. Pressure	Vacuum <sup>⑤</sup>	Overfill Safe	Viscosity cP (mPa.s)
<b>Coaxial GWR Probes—Liquids</b>									
7yT	Standard Temperature	Level/Interface	Tank/Chamber	$\epsilon_r$ 1.4–100	-40 to +400 °F (-40 to +200 °C)	1000 psi (70 bar)	Yes	Yes	500/2000
7yP	High Pressure	Level/Interface	Tank/Chamber	$\epsilon_r$ 1.4–100	-320 to +400 °F (-196 to +200 °C)	6250 psi (431 bar)	Full	Yes	500/2000
7yD	High Temp./High Press.	Level/Interface	Tank/Chamber	$\epsilon_r$ 1.4–100	-320 to +850 °F (-196 to +450 °C)	6250 psi (431 bar)	Full	Yes	500/2000
7yS	Steam Probe	Saturated Steam	Tank/Chamber	$\epsilon_r$ 10–100	-40 to +800 °F <sup>⑥</sup> (-40 to +425 °C)	3000 psi (207 bar)	Full	No <sup>⑦</sup>	500
<b>Caged GWR Probes—Liquids</b>									
7yG	Standard Temperature	Level/Interface	Chamber	$\epsilon_r$ 1.4–100	-40 to +400 °F (-40 to +200 °C)	1000 psi (70 bar)	Yes	Yes	10000
7yL	High Pressure	Level/Interface	Chamber	$\epsilon_r$ 1.4–100	-320 to +400 °F (-196 to +200 °C)	6250 psi (431 bar)	Full	Yes	10000
7yJ	High Temp./High Press.	Level/Interface	Chamber	$\epsilon_r$ 1.4–100	-320 to +850 °F (-196 to +450 °C)	6250 psi (431 bar)	Full	Yes	10000
<b>Single Rod Rigid GWR Probes—Liquids</b>									
7yF	Standard Temperature	Level	Tank	$\epsilon_r$ 1.7–100	-40 to +400 °F (-40 to +200 °C)	1000 psi (70 bar)	Yes	No <sup>⑧</sup>	10000
7yM	High Pressure	Level	Tank	$\epsilon_r$ 1.7–100	-320 to +400 °F (-196 to +200 °C)	6250 psi (431 bar)	Full	No <sup>⑧</sup>	10000
7yN	High Temp./High Press.	Level	Tank	$\epsilon_r$ 1.7–100	-320 to +850 °F (-196 to +450 °C)	6250 psi (431 bar)	Full	No <sup>⑧</sup>	10000
<b>Single Cable Flexible GWR Probes—Liquids</b>									
7y1	Standard Temperature	Level	Tank	$\epsilon_r$ 1.7–100	-40 to +400 °F (-40 to +200 °C)	1000 psi (70 bar)	Yes	No <sup>⑧</sup>	10000
7y3	High Pressure	Level	Tank	$\epsilon_r$ 1.7–100	-320 to +400 °F (-196 to +200 °C)	6250 psi (431 bar)	Full	No <sup>⑧</sup>	10000
7y4 <sup>⑨</sup>	Standard Temperature	Level/Interface	Chamber	$\epsilon_r$ 1.4–100	-40 to +400 °F (-40 to +200 °C)	1000 psi (70 bar)	Yes	No <sup>⑧</sup>	10000
7y6	High Temp./High Press.	Level/Interface	Chamber	$\epsilon_r$ 1.4–100	-320 to +850 °F (-196 to +450 °C)	6250 psi (431 bar)	Full	No <sup>⑧</sup>	10000
<b>Twin Cable Flexible GWR Probes—Liquids</b>									
7y7	Standard Temperature	Level/Interface	Tank	$\epsilon_r$ 1.7–100	-40 to +400 °F (-40 to +200 °C)	1000 psi (70 bar)	Yes	No <sup>⑧</sup>	1500
<b>Single Cable Flexible GWR Probes—Solids</b>									
7y2	Bulk Solids Probe	Level	Tank	$\epsilon_r$ 4–100	-40 to +150 °F (-40 to +65 °C)	Atmos.	No	No <sup>⑧</sup>	10000
<b>Twin Cable Flexible GWR Probes—Solids</b>									
7y5	Bulk Solids Probe	Level	Tank	$\epsilon_r$ 1.7–100	-40 to +150 °F (-40 to +65 °C)	Atmos.	No	No <sup>⑧</sup>	1500

① 2<sup>nd</sup> digit A=English, C=Metric

② Minimum  $\epsilon_r$  1.2 with end of probe analysis enabled.

③ Single rod probes mounted directly into the vessel must be within 3–6 inches of metal tank wall to obtain minimum dielectric of 1.4, otherwise  $\epsilon_r$  min = 1.7.

④ Depends on the probe spacer material. Refer to Model Selection for spacer options.

⑤ ECLIPSE probes containing o-rings can be used for vacuum (negative pressure) service, but only those probes with glass seals are hermetically sealed to <10<sup>-8</sup> cc/sec @ 1 atmosphere helium.

⑥ When installed in side-mounted chamber.

⑦ Consult factory for overfill applications.

⑧ Overfill capability can be achieved with software.

⑨ Scheduled for future release.



# TRANSMITTER SPECIFICATIONS

## FUNCTIONAL/PHYSICAL

<b>System Design</b>	
Measurement Principle	Guided Wave Radar based on Time Domain Reflectometry (TDR)
<b>Input</b>	
Measured Variable	Level, as determined by GWR time of flight
Span	6 inches to 100 feet (15 cm to 30 m); Model 7yS Probe 20 feet (610 cm) max.
<b>Output</b>	
Type	4 to 20 mA with HART: 3.8 mA to 20.5 mA useable (per NAMUR NE43) FOUNDATION fieldbus™: H1 (ITK Ver. 6.2.0) PROFIBUS PA Modbus
Resolution	Analog: .003 mA Digital Display: 1 mm
Loop Resistance	591 ohms @ 24 VDC and 22 mA
Diagnostic Alarm	Selectable: 3.6 mA, 22 mA (meets requirements of NAMUR NE 43), or HOLD last output
Diagnostic Indication	Meets requirements of NAMUR NE107
Damping	Adjustable 0–10 seconds
<b>User Interface</b>	
Keypad	4-button menu-driven data entry
Display	Graphic liquid crystal display
Digital Communication/Systems	HART Version 7—with Field Communicator, AMS, or FDT DTM (PACTware™), EDDL FOUNDATION fieldbus, PROFIBUS PA or Modbus
Menu Languages	Transmitter LCD: English, French, German, Spanish, Russian HART DD: English, French, German, Spanish, Russian, Chinese, Portuguese FOUNDATION fieldbus, PROFIBUS PA and Modbus Host System: English
<b>Power</b> (at transmitter terminals)	HART: General Purpose (Weatherproof)/Intrinsically Safe/Explosion-proof: 16 to 36 VDC 11 VDC minimum under certain conditions (refer to I&O Manual 57-606) FOUNDATION fieldbus and PROFIBUS PA: 9 to 17.5 VDC FISCO ia / FNICO ic, Explosion Proof, General Purpose and Weatherproof Modbus: 8 to 30 VDC Explosion Proof, General Purpose, and Weatherproof
<b>Housing</b>	
Material	IP67/die-cast aluminum A413 (<0.6% copper); optional stainless steel
Net/Gross Weight	Aluminum: 4.5 lbs. (2.0 kg) Stainless Steel: 10.0 lbs. (4.50 kg)
Overall Dimensions	H 8.34" (212 mm) x W 4.03" (102 mm) x D 7.56" (192 mm)
Cable Entry	½" NPT or M20
SIL 2/3 Capable (Certified)	Safe Failure Fraction = 93% (HART only) Functional Safety to SIL 2/3 in accordance with IEC 61508

# TRANSMITTER SPECIFICATIONS CONTINUED

## FUNCTIONAL/PHYSICAL

Environment	
Operating Temperature	-40 to +175 °F (-40 to +80 °C); LCD viewable -5 to +160 °F (-20 to +70 °C)
Storage Temperature	-50 to +185 °F (-45 to +85 °C)
Humidity	0 to 99%, non-condensing
Electromagnetic Compatibility	Meets CE requirement (EN 61326) and NAMUR NE 21 ①
Surge Protection	Meets CE EN 61326 (1000V)
Shock/Vibration	ANSI/ISA-S71.03 Class SA1 (Shock); ANSI/ISA-S71.03 Class VC2 (Vibration)
Performance	
Reference Conditions ②	Reflection from liquid, with dielectric constant in center of selected range, with a 72" (1.8 m) coaxial probe at +70 °F (+20 °C), in Auto Threshold Mode
Linearity ③	Coaxial/Caged Probes: <0.1% of probe length or 0.1 inch (2.5 mm), whichever is greater Single Rod in Tanks/Twin Cable: <0.3% of probe length or 0.3 inch (7.5 mm), whichever is greater
Accuracy ④	Coaxial/Caged Probes: ±0.1% of probe length or ±0.1 inch (2.5 mm), whichever is greater Single Rod in Tanks/Twin Cable: ±0.5% of probe length or ±0.5 inch (13 mm), whichever is greater
	Interface Operation: Coaxial/Caged probes: ±1 inch (25 mm) for an interface thickness greater than 2 inches (50 mm) Twin Flexible probes: ±2 inch (50 mm) for an interface thickness greater than 8 inches (200 mm)
Resolution	±0.1 inch or 1 mm
Repeatability	<0.1 inch (2.5 mm)
Hysteresis	<0.1 inch (2.5 mm)
Response Time	Approximately 1 second
Initialization Time	Less than 10 seconds
Ambient Temperature Effect	Approx. ±0.02% of probe length/degree C (for probes greater than 8 feet (2.5 m))
Process Dielectric	<0.3 inch (7.5 mm) within selected range
FOUNDATION fieldbus™	
ITK Version	6.2.0
H1 Device Class	Link Master (LAS)—selectable ON/OFF
Function Blocks	(8) AI, (3) Transducer, (1) Resource, (1) Arithmetic, (1) Input Selector, (1) Signal Characterizer, (2) PID, (1) Integrator
Quiescent Current	15 mA
Execution Time	15 ms (40 ms PID Block)
Device Revision	02
DD Version	0x01
PROFIBUS PA	
Device Revision	0x101A
Digital Communication Protocol	Version 3.02 MBP (31.25 kbits/sec)
Function Blocks	(1) × Physical Block, (8) × AI Blocks, (3) × Transducer Block
Quiescent Current	15 mA
Execution Time	15 ms
Modbus	
Power Consumption	<0.5W
Signal Wiring	Two-wire half duplex RS-485 Modbus
Ground (common mode) Voltage	±7V
Bus Termination	Per EIA-485

① Single rod and twin cable probes must be used in metallic vessel or stillwell to maintain CE noise immunity

② Specifications will degrade in Fixed Threshold mode.

③ Linearity in top 18 inches (46 cm) of twin cable and single rod probes in tanks will be application dependent.

④ Accuracy may degrade when using manual or automatic compensation.

# COAXIAL PROBE MATRIX

	7yT	7yP
<b>Description</b>	Standard Temperature	High Pressure
<b>Application</b>	Level/Interface	Level/Interface
<b>Installation</b>	Tank/Chamber	Tank/Chamber
<b>Overfill Safe</b>	Yes	Yes
<b>Materials – Probe</b>	316/316L (1.4401/1.4404) Hastelloy® C (2.4819) Monel® (2.4360)	316/316L (1.4401/1.4404) Hastelloy® C (2.4819) Monel® (2.4360)
<b>Process Seal</b>	Teflon® TFE with Viton® o-rings ①	Hermetic Glass Ceramic, Inconel ⑦
<b>Spacers</b>	Teflon® TFE	Teflon® TFE
<b>Probe Outside Diameter</b>		
<b>Enlarged</b>	316 SS: 1.75" (45 mm) Hastelloy: 1.90" (49 mm) Monel: 1.90" (49 mm)	316 SS: 1.75" (45 mm) Hastelloy: 1.90" (49 mm) Monel: 1.90" (49 mm)
<b>Basic</b>	0.87" (22.5 mm)	0.87" (22.5 mm)
<b>Process Connection</b>		
<b>Threaded</b>	Enlarged 2" NPT (¾" NPT or 1" BSP)	Enlarged 2" NPT (¾" NPT or 1" BSP)
<b>Flanged</b>	Various ASME, EN1092, and proprietary flanges	Various ASME, EN1092, and proprietary flanges
<b>Available Probe Length</b>		
<b>Standard</b>	12 to 240 inches (30 to 610 cm)	12 to 240 inches (30 to 610 cm)
<b>Enlarged</b>	30 feet (9 m) max. segmented	30 feet (9 m) max. segmented
<b>Transition Zones ②</b>		
<b>Top</b>	0 inches (0 mm)	0 inches (0 mm)
<b>Bottom</b>	$\epsilon_r = 1.4$ : 6 inches (150 mm) ⑤, $\epsilon_r = 80$ : 2 inches (50 mm)	$\epsilon_r = 1.4$ : 6 inches (150 mm) ⑤, $\epsilon_r = 80$ : 2 inches (50 mm)
<b>Process Temperature</b>	-40 to +400 °F (-40 to +200 °C)	-320 to +400 °F (-196 to +200 °C)
<b>Max. Process Pressure ③</b>	1000 psi @ +70 °F (70 bar @ +20 °C)	6250 psi @ +70°F (431 bar @ +20°C)
<b>Dielectric Range</b>	1.4 to 100 ⑥	1.4 to 100 ⑥
<b>Vacuum Service ④</b>	Negative Pressure, but no hermetic seal	Full Vacuum
<b>Viscosity</b>		
<b>Enlarged</b>	2000cP (mPa.s)	2000cP (mPa.s)
<b>Basic</b>	500cP (mPa.s)	500cP (mPa.s)
<b>Media Coating</b>	Filming	Filming

① Other o-ring materials available upon request.

② Transition zones (areas with reduced accuracy) are dielectric dependent. It is recommended to set the 0-100% measuring range outside of the transition zones.

③ Refer to chart on page 16.

④ ECLIPSE probes containing o-rings can be used for vacuum (negative pressure) service, but only those probes with glass seal are hermetically sealed to  $<10^{-8}$  cc/sec @ 1 atmosphere helium.

⑤ Can be reduced to 3" (75 mm) when lower accuracy is acceptable.

⑥ 1.2 minimum dielectric when end of probe analysis is enabled.

⑦ Probes of Hastelloy C contain an Inconel 625 to Hastelloy C seal weld.

# COAXIAL PROBE MATRIX CONTINUED

	7yD	7yS
<b>Description</b>	High Temp./High Pressure	Steam Probe
<b>Application</b>	Level/Interface	Saturated Steam
<b>Installation</b>	Tank/Chamber	Tank/Chamber
<b>Overfill Safe</b>	Yes	No ⑥
<b>Materials – Probe</b>	316/316L (1.4401/1.4404) Hastelloy® C (2.4819) Monel® (2.4360)	316/316L (1.4401/1.4404) Hastelloy® C (2.4819)
<b>Process Seal</b>	Hermetic Glass Ceramic, Inconel ⑨	Hermetic Glass Ceramic, PEEK HT, Inconel ⑨
<b>Spacers</b>	PEEK HT/Ceramic	PEEK HT/Ceramic
<b>Probe Outside Diameter</b>		
<b>Enlarged</b>	316 SS: 1.75" (45 mm) Hastelloy: 1.92" (49 mm) Monel: 1.92" (49 mm)	N/A
<b>Basic</b>	0.87" (22.5 mm)	0.87" (22.5 mm)
<b>High-Temp Model 7YS</b>	N/A	1.25" (31.8 mm)
<b>Process Connection</b>		
<b>Threaded</b>	2" NPT or 2" BSP	¾" NPT or 1" BSP ⑦
<b>Flanged</b>	Various ASME, EN1092, and proprietary flanges	Various ASME, EN1092, and proprietary flanges
<b>Available Probe Length</b>		
<b>Standard</b>	12 to 240 inches (30 to 610 cm)	24 to 240 inches (60 to 610 cm)
<b>Enlarged</b>	30 feet (9 m) max. segmented	N/A
<b>Transition Zones ①</b>		
<b>Top</b>	0 inches (0 mm)	8 inches (200 mm)
<b>Bottom</b>	$\epsilon_r = 1.4$ : 6 inches (150 mm) ④, $\epsilon_r = 80$ : 2 inches (50 mm)	$\epsilon_r = 80$ : 2 inches (50 mm)
<b>Process Temperature</b>	-320 to +850 °F (-196 to 450 °C)	-58 to +800 °F (-50 to +425 °C) ⑧
<b>Max. Process Pressure ②</b>	6250 psi @ +70 °F (431 bar @ +20 °C)	3000 psi (207 bar)
<b>Dielectric Range</b>	1.4 to 100 ⑤	10 to 100
<b>Vacuum Service ③</b>	Full Vacuum	Full Vacuum
<b>Viscosity</b>		
<b>Enlarged</b>	2000cP (mPa.s)	N/A
<b>Basic</b>	500cP (mPa.s)	500cP (mPa.s)
<b>Media Coating</b>	Filming	Filming

① Transition zones (areas with reduced accuracy) are dielectric dependent. It is recommended to set the 0-100% measuring range outside of the transition zones.

② Refer to chart on page 16.

③ ECLIPSE probes containing o-rings can be used for vacuum (negative pressure) service, but only those probes with glass seal are hermetically sealed to <10<sup>-8</sup> cc/sec @ 1 atmosphere helium.

④ Can be reduced to 3" (75 mm) when lower accuracy is acceptable.

⑤ 1.2 minimum dielectric when end of probe analysis is enabled.

⑥ Consult factory for overfill applications.

⑦ Not available with +650 °F (+345 °C) version of the 7yS probe.

⑧ When installed in side-mounted chamber.

⑨ Probes of Hastelloy C contain an Inconel 625 to Hastelloy C seal weld.

# CAGED PROBE MATRIX

	7yG	7yL	7yJ
<b>Description</b>	Standard Temperature	High Pressure	High Temp./High Pressure
<b>Application</b>	Level/Interface	Level/Interface	Level/Interface
<b>Installation</b>	Chamber	Chamber	Chamber
<b>Overfill Safe</b> ⑦	Yes	Yes	Yes
<b>Materials – Probe</b>	316/316L (1.4401/1.4404) Hastelloy® C (2.4819) Monel® (2.4360)	316/316L (1.4401/1.4404) Hastelloy® C (2.4819) Monel® (2.4360)	316/316L (1.4401/1.4404) Hastelloy® C (2.4819) Monel® (2.4360)
<b>Process Seal</b>	Teflon® TFE with Viton® o-rings①	Hermetic Glass Ceramic, Inconel®	Hermetic Glass Ceramic, Inconel®
<b>Spacers</b>	PEEK	PEEK	PEEK HT/Celazole
<b>Probe Outside Diameter</b>			
<b>2" Chamber</b>	.5" (13 mm) to .75" (19 mm)	.5" (13 mm) to .75" (19 mm)	.5" (13 mm) to .75" (19 mm)
<b>3" Chamber</b>	.75" (19 mm) to 1.13" (29 mm)	.75" (19 mm) to 1.13" (29 mm)	.75" (19 mm) to 1.13" (29 mm)
<b>4" Chamber</b>	1.05" (27 mm) to 1.50" (38 mm)	1.05" (27 mm) to 1.50" (38 mm)	1.05" (27 mm) to 1.50" (38 mm)
<b>Process Connection</b>			
<b>Flanged</b>	Various ASME, EN1092, and proprietary flanges	Various ASME, EN1092, and proprietary flanges	Various ASME, EN1092, and proprietary flanges
<b>Available Probe Length</b>	12 to 240 inches (30 to 610 cm)	12 to 240 inches (30 to 610 cm)	12 to 240 inches (30 to 610 cm)
<b>Transition Zones</b> ②			
<b>Top</b>	0 inches (0 mm)	0 inches (0 mm)	0 inches (0 mm)
<b>Bottom</b>	$\epsilon_r = 1.4$ : 6 inches (150 mm) ⑤, $\epsilon_r = 80$ : 2 inches (50 mm)	$\epsilon_r = 1.4$ : 6 inches (150 mm) ⑤, $\epsilon_r = 80$ : 2 inches (50 mm)	$\epsilon_r = 1.4$ : 6 inches (150 mm) ⑤, $\epsilon_r = 80$ : 2 inches (50 mm)
<b>Process Temperature</b>	-40 to +400 °F (-40 to +200 °C)	-320 to +400 °F (-196 to +200 °C)	-320 to +850 °F (-196 to +450 °C)
<b>Max. Process Pressure</b> ③	1000 psi @ +70 °F (70 bar @ +20 °C)	6250 psi @ +70 °F (431 bar @ +20 °C)	6250 psi @ +70 °F (431 bar @ +20 °C)
<b>Dielectric Range</b> ⑦	1.4 to 100 ⑥	1.4 to 100 ⑥	1.4 to 100 ⑥
<b>Vacuum Service</b> ④	Negative Pressure, but no hermetic seal	Full Vacuum	Full Vacuum
<b>Viscosity</b>	10,000cP (mPa.s)	10,000cP (mPa.s)	10,000cP (mPa.s)
<b>Media Coating</b>	Maximum Error 10% of coated length (% Error is dependent on dielectric and thickness)	Maximum Error 10% of coated length (% Error is dependent on dielectric and thickness)	Maximum Error 10% of coated length (% Error is dependent on dielectric and thickness)

① Other o-ring materials available upon request.

② Transition zones (areas with reduced accuracy) are dielectric dependent. It is recommended to set the 0-100% measuring range outside of the transition zones.

③ Refer to chart on page 16.

④ ECLIPSE probes containing o-rings can be used for vacuum (negative pressure) service, but only those probes with glass seal are hermetically sealed to  $<10^{-8}$  cc/sec @ 1 atmosphere helium.

⑤ Can be reduced to 3" (75 mm) when lower accuracy is acceptable.

⑥ 1.2 minimum dielectric when end of probe analysis is enabled.

⑦ When installed in the proper chamber/cage/stilling well.

⑧ Probes of Hastelloy C contain an Inconel 625 to Hastelloy C seal weld.

# SINGLE ROD RIGID PROBE MATRIX

	7yF	7yM	7yN
<b>Description</b>	Standard Temperature	High Pressure	High Temp./High Pressure
<b>Application</b>	Level	Level	Level
<b>Installation</b>	Tank	Tank	Tank
<b>Overfill Safe</b> ⑦	No	No	No
<b>Materials – Probe</b>	316/316L (1.4401/1.4404) Hastelloy® C (2.4819) Monel® (2.4360) PFA Insulated 316/316L rod	316/316L (1.4401/1.4404) Hastelloy® C (2.4819) Monel® (2.4360)	316/316L (1.4401/1.4404) Hastelloy® C (2.4819) Monel® (2.4360)
<b>Process Seal</b>	Teflon® TFE with Viton® o-rings①	Hermetic Glass Ceramic, Inconel®	Hermetic Glass Ceramic, Inconel®
<b>Spacers</b>	None	None	PEEK HT/Celazole
<b>Probe Outside Diameter</b>	Bare: 0.38" (10 mm) rod Coated: 0.625" (16 mm) rod	Bare: 0.38" (10 mm) rod	Bare: 0.50" (13 mm) rod
<b>Process Connection</b> <b>Threaded</b> <b>Flanged</b>	1" or 2" (NPT or BSP) Various ASME, EN1092, and proprietary flanges	1" or 2" (NPT or BSP) Various ASME, EN1092, and proprietary flanges	2" (NPT or BSP) Various ASME, EN1092, and proprietary flanges
<b>Available Probe Length</b>	24 to 288 inches (60 to 732 cm) 240 inches (610 cm) maximum for PFA coated probes	24 to 288 inches (60 to 732 cm)	24 to 288 inches (60 to 732 cm)
<b>Transition Zones</b> ② <b>Top</b> <b>Bottom</b>	Application Dependent $\epsilon_r = 1.4$ : 6 inches (150 mm) ⑤, $\epsilon_r = 80$ : 2 inches (50 mm)	Application Dependent $\epsilon_r = 1.4$ : 6 inches (150 mm) ⑤, $\epsilon_r = 80$ : 2 inches (50 mm)	Application Dependent $\epsilon_r = 1.4$ : 6 inches (150 mm) ⑤, $\epsilon_r = 80$ : 2 inches (50 mm)
<b>Process Temperature</b>	-40 to +400 °F (-40 to +200 °C)	-320 to +400 °F (-196 to +200 °C)	-320 to +850 °F (-196 to +450 °C)
<b>Max. Process Pressure</b> ③	1000 psi @ +70 °F (70 bar @ +20 °C)	6250 psi @ +70 °F (431 bar @ +20 °C)	6250 psi @ +70 °F (431 bar @ +20 °C)
<b>Dielectric Range</b>	1.7 to 100 ⑥	1.7 to 100 ⑥	1.7 to 100 ⑥
<b>Vacuum Service</b> ④	Negative Pressure, but no hermetic seal	Full Vacuum	Full Vacuum
<b>Viscosity</b>	10,000cP (mPa.s)	10,000cP (mPa.s)	10,000cP (mPa.s)
<b>Media Coating</b>	Maximum Error 10% of coated length (% Error is dependent on dielectric and thickness)	Maximum Error 10% of coated length (% Error is dependent on dielectric and thickness)	Maximum Error 10% of coated length (% Error is dependent on dielectric and thickness)

① Other o-ring materials available upon request.

② Transition zones (areas with reduced accuracy) are dielectric dependent. It is recommended to set the 0-100% measuring range outside of the transition zones.

③ Refer to chart on page 16.

④ ECLIPSE probes containing o-rings can be used for vacuum (negative pressure) service, but only those probes with glass seal are hermetically sealed to <math>10^{-8}</math> cc/sec @ 1 atmosphere helium.

⑤ Can be reduced to 3" (75 mm) when lower accuracy is acceptable.

⑥ 1.2 minimum dielectric when end of probe analysis is enabled.

⑦ Overfill capability can be achieved with software.

⑧ Probes of Hastelloy C contain an Inconel 625 to Hastelloy C seal weld.

# FLEXIBLE PROBES FOR LIQUIDS MATRIX

	7y1	7y3
<b>Description</b>	Single Flexible Standard Temperature	Single Flexible High Pressure
<b>Application</b>	Level	Level
<b>Installation</b>	Tank	Tank
<b>Overfill Safe</b> ⑥	No	No
<b>Materials – Cable</b>	316 (1.4401) (optional PFA coating)	316 (1.4401)
<b>Process Seal</b>	Teflon® TFE with Viton® o-rings <sup>①</sup>	Hermetic Glass Ceramic, Inconel <sup>⑦</sup>
<b>Probe Outside Diameter</b>	0.19 inches (5 mm)	0.19 inches (5 mm)
<b>Process Connection</b>  <b>Threaded</b> <b>Flanged</b>	2" NPT or 2" BSP Various ASME, EN1092, and proprietary flanges	2" NPT or 2" BSP Various ASME, EN1092, and proprietary flanges
<b>Available Probe Length</b>	3 to 100 feet (1 to 30 meters)	3 to 100 feet (1 to 30 meters)
<b>Transition Zones</b> ②  <b>Top</b> <b>Bottom</b>	18 inches (45 cm) 12 inches (30 cm)	18 inches (45 cm) 12 inches (30 cm)
<b>Process Temperature</b>	-40 to +400 °F (-40 to +200 °C)	-320 to +400 °F (-196 to +200 °C)
<b>Max. Process Pressure</b> ③	1000 psi @ +70 °F (70 bar @ +20 °C)	6250 psi @ +70 °F (431 bar @ +20 °C)
<b>Dielectric Range</b> ⑤	1.7 to 100	1.7 to 100
<b>Vacuum Service</b> ④	Negative Pressure, but no hermetic seal	Full Vacuum
<b>Viscosity</b>	10,000 (mPa.s)	10,000 (mPa.s)
<b>Media Coating</b>	Maximum Error 10% of coated length (% Error is dependent on dielectric and thickness)	Maximum Error 10% of coated length (% Error is dependent on dielectric and thickness)

① Other o-ring materials available upon request.

② Transition zones (areas with reduced accuracy) are dielectric dependent. It is recommended to set the 0-100% measuring range outside of the transition zones.

③ Refer to chart on page 16.

④ ECLIPSE probes containing o-rings can be used for vacuum (negative pressure) service, but only those probes with glass seal are hermetically sealed to <10<sup>-8</sup> cc/sec @ 1 atmosphere helium.

⑤ 1.2 minimum dielectric when end of probe analysis is enabled.

⑥ Overfill capability can be achieved with software.

⑦ Probes of Hastelloy C contain an Inconel 625 to Hastelloy C seal weld.

# FLEXIBLE PROBES FOR LIQUIDS MATRIX CONTINUED

	7y4 (Future)	7y6	7y7
<b>Description</b>	Single Flexible Standard Temperature	Single Flexible HTHP	Twin Flexible Standard Temperature
<b>Application</b>	Level	Level	Level/Interface
<b>Installation</b>	Chamber	Tank/Chamber	Tank/Chamber
<b>Overfill Safe</b>	No	No	No
<b>Materials – Cable</b>	316 (1.4401)	316 (1.4401)	316 SS (1.4401) Cables with FEP Webbing
<b>Process Seal</b> ①	Teflon® TFE with Viton® o-rings	Hermetic Glass Ceramic, Inconel ⑥	Teflon® TFE with Viton® o-rings
<b>Cable Outside Diameter</b>	0.19 inches (5 mm)	0.19 inches (5 mm)	(2) 0.25 inches (6 mm)
<b>Process Connection</b>			
<b>Threaded Flanged</b>	2" NPT or 2" BSP Various ASME, EN, and proprietary flanges	2" NPT or 2" BSP Various ASME, EN, and proprietary flanges	2" NPT or 2" BSP Various ASME, EN, and proprietary flanges
<b>Available Probe Length</b>	3 to 100 feet (1 to 30 meters)	3 to 100 feet (1 to 30 meters)	3 to 100 feet (1 to 30 meters)
<b>Transition Zones</b> ②			
<b>Top</b>	18 inches (45 cm)	18 inches (45 cm)	18 inches (45 cm)
<b>Bottom</b>	12 inches (30 cm)	12 inches (30 cm)	12 inches (30 cm)
<b>Process Temperature</b>	-40 to +400 °F (-40 to +200 °C)	-320 to +850 °F (-196 to +450 °C)	-40 to +400 °F (-40 to +200 °C)
<b>Max. Process Pressure</b> ③	1000 psi @ +70 °F (70 bar @ +20 °C)	6250 psi @ +70 °F (431 bar @ +20 °C)	1000 psi @ +70 °F (70 bar @ +20 °C)
<b>Dielectric Range</b> ⑤	1.7 to 100	1.7 to 100	1.7 to 100
<b>Vacuum Service</b> ④	Negative Pressure, but no hermetic seal	Full Vacuum	Negative Pressure, but no hermetic seal
<b>Viscosity</b>	10,000 (mPa.s)	10,000 (mPa.s)	1500 (mPa.s)
<b>Media Coating</b>	Maximum Error 10% of coated length (% Error is dependent on dielectric and thickness)	Maximum Error 10% of coated length (% Error is dependent on dielectric and thickness)	Maximum Error 10% of coated length (% Error is dependent on dielectric and thickness)

① Other o-ring materials available upon request.

② Transition zones (areas with reduced accuracy) are dielectric dependent. It is recommended to set the 0-100% measuring range outside of the transition zones.

③ Refer to chart on page 16.

④ ECLIPSE probes containing o-rings can be used for vacuum (negative pressure) service, but only those probes with glass seal are hermetically sealed to <10<sup>-8</sup> cc/sec @ 1 atmosphere helium.

⑤ 1.2 minimum dielectric when end of probe analysis is enabled.

⑥ Probes of Hastelloy C contain an Inconel 625 to Hastelloy C seal weld.



# FLEXIBLE PROBES FOR SOLIDS MATRIX

	7y2	7y5
<b>Description</b>	Single Flexible Standard Temp.	Twin Flexible Standard Temp.
<b>Application</b>	Level	Level
<b>Installation</b>	Tank	Tank
<b>Overfill Safe</b>	No	No
<b>Pull Down Force</b>	3000 lbs. (1360 Kg)	3000 lbs (1360 Kg)
<b>Materials – Cable</b>	316 (1.4401)	316 (1.4401)
<b>Probe Outside Diameter</b>	0.19 inches (5 mm)	(2) 0.25 inches (6 mm)
<b>Process Connection</b>		
<b>Threaded</b>	2" NPT or 2" BSP	2" NPT or 2" BSP
<b>Flanged</b>	Various ASME, EN1092, and proprietary flanges	Various ASME, EN1092, and proprietary flanges
<b>Available Probe Length</b>	3 to 100 feet (1 to 30 meters)	3 to 100 feet (1 to 30 meters)
<b>Transition Zones</b> ①		
<b>Top</b>	18 inches (45 cm)	18 inches (45 cm)
<b>Bottom</b>	12 inches (30 cm)	12 inches (30 cm)
<b>Dielectric Range</b> ②	1.7 to 100	1.7 to 100
<b>Vacuum Service</b> ③	Negative Pressure, but no hermetic seal	Negative Pressure, but no hermetic seal
<b>Viscosity</b>	10,000 (mPa.s)	10,000 (mPa.s)
<b>Media Coating</b>	Max. Error 10% of coated length (% Error is dependent on dielectric & thickness)	Max. Error 10% of coated length (% Error is dependent on dielectric & thickness)

- ① Transition zones (areas with reduced accuracy) are dielectric dependent. It is recommended to set the 0-100% measuring range outside of the transition zones.
- ② 1.2 minimum dielectric when end of probe analysis is enabled.
- ③ ECLIPSE probes containing o-rings can be used for vacuum (negative pressure) service, but only those probes with glass seal are hermetically sealed (helium leak <10<sup>-6</sup>cc/sec @ 1 atmos.).

**7yL, 7yM and 7yP  
Temperature/Pressure Ratings**

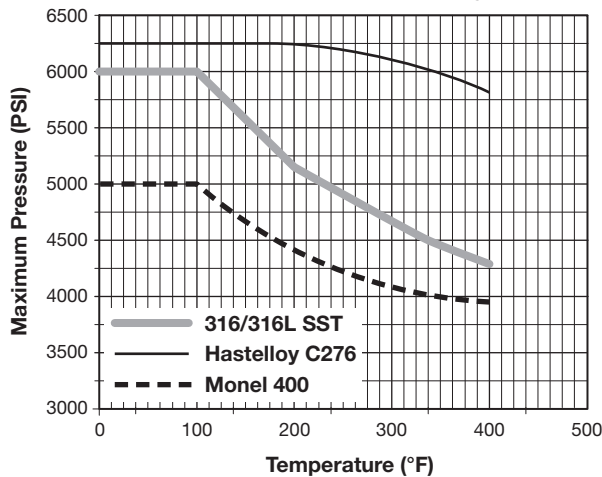

**7yD, 7yJ, 7yN, 7y3 and 7y6  
Temperature/Pressure Ratings**

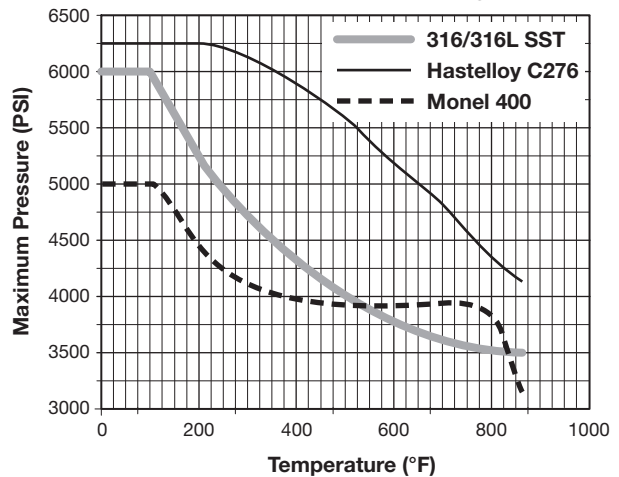

High Pressure Probes					Low Pressure				
Temp.	SST	Hastelloy	Monel	All Materials	Temp.	SST	Hastelloy	Monel	All Materials
-40	6000	6250	5000	750	+600	3760	5040	3940	—
+70	6000	6250	5000	1000	+650	3680	4905	3940	—
+100	6000	6250	5000	1000	+700	3620	4730	3920	—
+200	5160	6250	4380	650	+750	3560	4430	3880	—
+300	4660	6070	4080	400	+800	3520	4230	3820	—
+400	4280	5820	3940	270	+850	3480	4060	3145	—
+500	3980	5540	3940	—					

**7yF, 7yG, 7yT, 7y1, 7y4, 7y7**

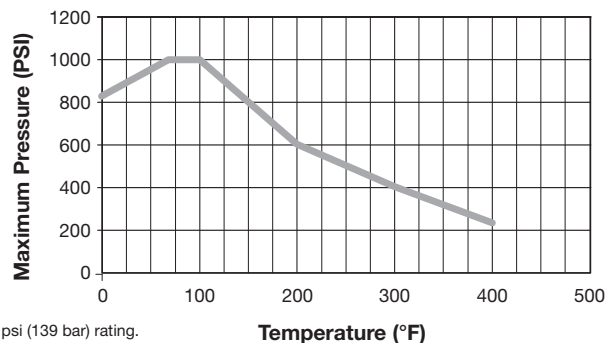

- 7yS steam probes are rated to 2200 psi (155 bar) up to +650 °F (+345 °C)
- 7y3, 7y6 flexible probes: Pressure is limited by the chamber
- 7y2, 7y5 bulk solids probes: 50 psi (3.45 bar) to +150 °F (+65 °C)
- High pressure probes with threaded fittings are rated as follows: 7yD, 7yN, 7yP and 7y3 probes with threaded fittings have 3600 psi (248 bar) rating. 7yM probes with threaded fittings have 2016 psi (139 bar) rating.
- Maximum pressure for 1" NPT or 1" BSP:  
316 SST probe: 139 bar (2016 psi) • Hast. C276 probe: 145 bar (2100 psi) • Monel probe: 116 bar (1680 psi)
- Maximum pressure for 2" NPT or 2" BSP:  
316 SST probe: 414 bar (6000 psi) • Hast. C276 probe: 431 bar (6250 psi) • Monel probe: 345 bar (5000 psi)

# O-RING (SEAL) SELECTION CHART

## O-RING/SEAL SPECIFICATIONS

Code	"O"-Ring Material	Max. Process Temperature	Min. Process Temperature	Max. Process Pressure	Not Recommended For Applications	Recommended for Applications
0	<b>Viton® GFLT</b>	400 °F @ 230 psi (200 °C @ 16 bar)	-40 °F (-40 °C)	1000 psi 70 °F (70 bar @ 20 °C)	Ketones (MEK, acetone), skydrol fluids, amines, anhydrous ammonia, low molecular weight esters and ethers, hot hydrofluoric or chlorosulfuric acids, sour HCs	General purpose, ethylene
1	<b>EPDM</b>	250 °F @ 200 psi (120 °C @ 14 bar)	-60 °F (-50 °C)	1000 psi 70 °F (70 bar @ 20 °C)	Petroleum oils, di-ester base lubricant, steam	Acetone, MEK, skydrol fluids
2	<b>Kalrez® 4079</b>	400 °F @ 232 psi (200 °C @ 16 bar)	-40 °F (-40 °C)	1000 psi 70 °F (70 bar @ 20 °C)	Hot water/steam, hot aliphatic amines, ethylene oxide, propylene oxide	Inorganic and organic acids (including hydro fluids and nitric), aldehydes, ethylene, organic oils, glycols, silicone oils, vinegar, sour HCs
3	<b>HSN</b> (Highly Saturated Nitrile)	275 °F @ 320 psi (135 °C @ 22 bar)	-4 °F (-20 °C)	1000 psi 70 °F (70 bar @ 20 °C)	Halogenated HCs, nitro HCs, phosphate ester hydraulic fluids, ketones (MEK, acetone), strong acids, ozone, automotive brake fluid, steam	NACE applications
4	<b>Buna-N</b>	275 °F @ 320 psi (135 °C @ 22 bar)	-4 °F (-20 °C)	1000 psi 70 °F (70 bar @ 20 °C)	Halogenated HCs, nitro HCs, phosphate ester hydraulic fluids, ketones (MEK, acetone), strong acids, ozone, automotive brake fluid	General purpose sealing, petroleum oils and fluids, cold water, silicone greases and oils, di-ester base lubricants, ethylene glycol base fluids
5	<b>Neoprene®</b>	250 °F @ 290 psi (120 °C @ 20 bar)	-65 °F (-55 °C)	1000 psi 70 °F (70 bar @ 20 °C)	Phosphate ester fluids, ketones (MEK, acetone)	Refrigerants, high anline point petroleum oils, silicate ester lubricants
6	<b>Chemraz® 505</b>	400 °F @ 200 psi (200 °C @ 14 bar)	-20 °F (-30 °C)	1000 psi 70 °F (70 bar @ 20 °C)	Acetaldehyde, ammonia + lithium metal solution, butyraldehyde, di-water, freon, ethylene oxide, liquors, isobutyraldehyde	Inorganic and organic acids, alkalines, ketones, esters, aldehydes, fuels
7	<b>Polyurethane</b>	200 °F @ 420 psi (95 °C @ 29 bar)	-65 °F (-55 °C)	1000 psi 70 °F (70 bar @ 20 °C)	Acids, Ketones, chlorinated HCs,	Hydraulic systems, petroleum oils, HC fuel, oxygen, ozone
8	<b>Simriz SZ485</b> (formerly Aegis PF128) ①	400 °F @ 232 psi (200 °C @ 16 bar)	-4 °F (-20 °C)	1000 psi 70 °F (70 bar @ 20 °C)	Black liquor, freon 43, freon 75, galden, KEL-F liquid, molten potassium, molten sodium	Inorganic and organic acids (including hydro fluids and nitric), aldehydes, ethylene, organic oils, glycols, silicone oils, vinegar, sour HCs, steam, amines, ethylene oxide, propylene oxide, NACE applications
A	<b>Kalrez® 6375</b>	400 °F @ 232 psi (200 °C @ 16 bar)	-40 °F (-40 °C)	1000 psi 70 °F (70 bar @ 20 °C)	Hot water/steam, hot aliphatic amines	Inorganic and organic acids (including hydro fluids and nitric), aldehydes, ethylene, organic oils, glycols, silicone oils, vinegar, sour HCs. ethylene oxide, propylene oxide
B	<b>Kalrez® 6375</b>	400 °F @ 232 psi (200 °C @ 16 bar)	-40 °F (-40 °C)	1000 psi 70 °F (70 bar @ 20 °C)	Hot water/steam, hot aliphatic amines, ethylene oxide, propylene oxide	Hydrofluoric Acid
D or N	<b>Glass Ceramic Alloy</b>	850 °F @ 3600 psi (450 °C @ 248 bar)	-320 °F (-195 °C)	6250 psi 70 °F (431 bar @ 20 °C)	Hot alkaline solutions HF acid, media with ph>12, direct exposure to saturated steam	General high temperature/high pressure applications, hydrocarbons, full vacuum (hermetic), ammonia, chlorine

① Maximum +300 °F (+150 °C) for use on steam.

# REPLACEMENT OF DISPLACER TRANSMITTERS

ECLIPSE has proven to be the ideal replacement for existing torque tube transmitters. In numerous applications worldwide, customers have found the performance of ECLIPSE Guided Wave Radar transmitters to be superior to that of antiquated torque tube transmitters.

There are several benefits to using the ECLIPSE Model 706 as a replacement for torque tube transmitters:

- **Cost:**  
The cost of a new Model 706 transmitter cost is comparable to rebuilding an aging torque tube.
- **Installation:**  
No field calibration is necessary. The Model 706 transmitter can be configured in minutes with no level movement. (Complete factory pre-configuration is available, which can further decrease the installation effort).
- **Performance:**  
The ECLIPSE Model 706 is unaffected by changes in specific gravity and has no moving parts that can wear and lose tolerance.

- **Ease of replacement:**  
Proprietary and standard ASME flanges are offered on all ECLIPSE Model 706 probes so existing chamber/cages can be used.

In order to match the proper ECLIPSE transmitter with the proper external cage, consider the following:

- **Type of application:**  
Use the proper GWR probe for the application, see pages 7 and 10 through 16.

- **Overfill proof:**  
For optimum performance, use an Overfill-safe probe in all chamber applications.

**Note:** “Overfill” occurs when the level rises above the maximum range of operation. *Some GWR probes may provide erroneous output in this zone unless an optimal, impedance-matched design is used.*

- **Minimum Cage Size:**
  - Coaxial or Caged Coaxial probes: 2" minimum
  - Enlarged Coaxial probes: 3" minimum
  - Twin Cable probes: 4" minimum

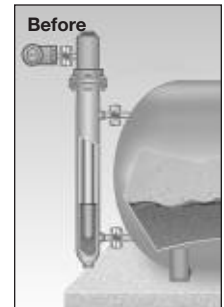
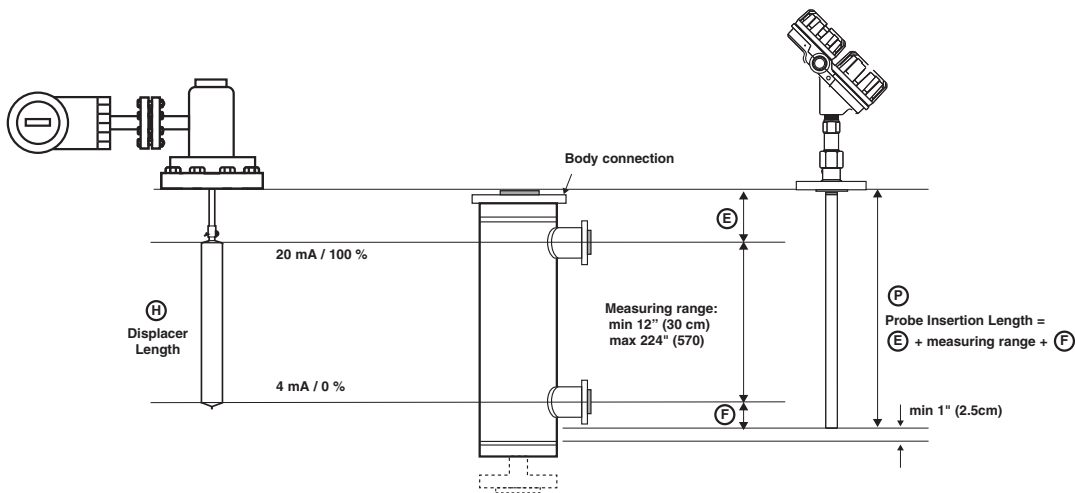

## Recommended probe length for replacing displacer transmitters

The table below helps to define the GWR probe length for the most common displacer transmitters. Refer to the proprietary flange selection guide.

Manufacturer	Type	Process Connection	Displacer Length inches (mm)	Probe Length ① inches (mm)
MAGNETROL	EZ & PN Modulevel®	ASME/EN flange	≥ 14" (356)	Displacer + 7 (178)
Masoneilan®	Series 1200	Proprietary flange	≥ 14" (356)	Displacer + 8 (203)
		ASME/EN flange	≥ 16" (406)	Displacer + 8 (203)
Fisher® series 2300 & 2500	249B, 259B, 249C cages	Proprietary flange	≥ 14" (356)	Displacer + 10 (254)
	other cages	ASME flange	≥ 14" (356)	consult factory
Eckardt®	Series 134, 144	ASME/EN flange	≥ 14" (356)	consult factory
Tokyo Keiso®	FST-3000	ASME/EN flange	H = 11.8" (300)	Displacer + 9 (229)
		ASME/EN flange	≥ H = 19.7" (500)	Displacer + 9 (229)

① Round down resulting calculation to the nearest inch.

# PROPRIETARY FLANGES

INCHES (mm)

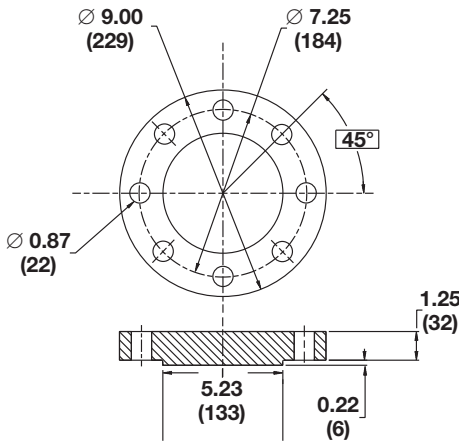

Fisher 249B/259B (600 lb.), carbon steel

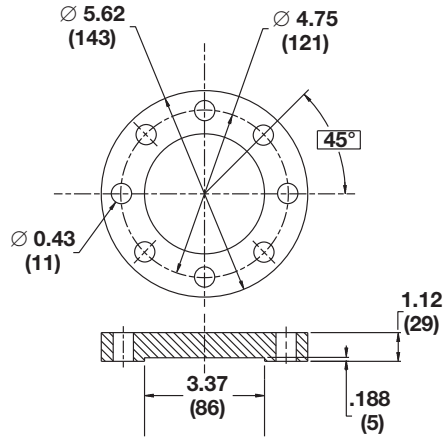

Fisher 249C (600 lb.), 316 stainless steel

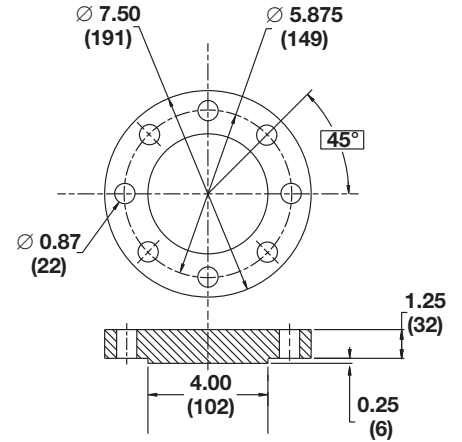

Masoneilan (600 lb.), carbon steel

# MAGNETROL CHAMBERS

A brief description of the MAGNETROL chamber offering follows. For more details, refer to MAGNETROL Sales Bulletin 41-140.

MAGNETROL has a long tradition in offering cost-effective chambers. The MAGNETROL external chamber is a self-contained cage designed for use with our top mounting level transmitters or switches. Quality construction and a wide selection of configurations make this cage an ideal means of utilizing the power of Guided Wave Radar without mounting directly into the process vessel.



MAGNETROL chambers are available with a wide variety of options, and can be manufactured to comply with various regulations such as:

- Commercial Design
- ASME B31.1 Design Code
- ASME B31.3 Design Code
- NACE Design Code
- PED

Some Model 706 probes can be installed into chambers as small as 2". When a new chamber is required, it can be

ordered together with a factory pre-configured Model 706 for a true "plug and play" installation.

**For example:**

A standard Model 706-511A-310 explosion-proof transmitter with a Model 7AG-4300-A10-00-021 Caged probe can be used in a 2" chamber. A typical chamber Model Number would be:

**F21-4A2D-014**

Refer to MAGNETROL Sales Bulletin 41-140 for details on chamber Model Numbers and additional options.

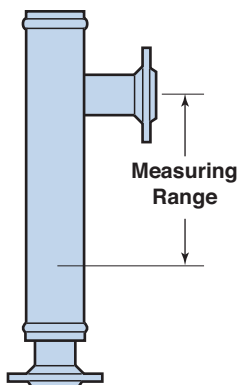

Sealed Chamber

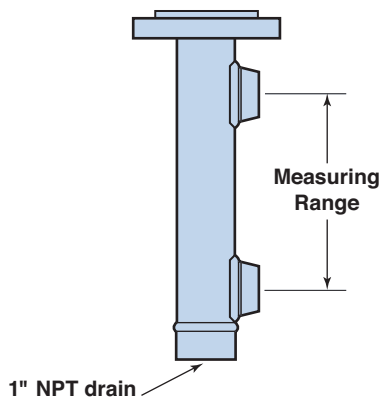

Slip-on head flange

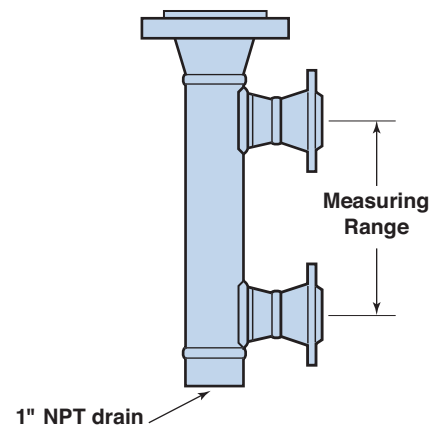

Weld neck head flange



These units are in compliance with the EMC-directive 2014/30/EU, the PED-directive 2014/68/EU and the ATEX directive 2014/34/EU.

<p><b>Explosion Proof (with intrinsically Safe Probe)</b></p> <p><b>US/Canada:</b>                  Class I, Div 1, Group B, C and D, T4                  Class I, Zone 1 AEx d/ia [ia IIC Ga] IIB + H2 T4 Gb/Ga                  Class I, Zone 1 Ex d/ia [ia IIC Ga] IIB + H2 T4 Gb/Ga                  Ta = -40°C to +70°C                  Type 4X, IP67</p> <p><b>Flame Proof</b></p> <p><b>ATEX – FM14ATEX0041X:</b>                  II 2/1 G Ex d/ia [ia IIC Ga] IIB + H2 T6 to T1 Gb/Ga                  Ta = -40°C to +70°C                  IP67</p> <p><b>IEC- IECEx FMG 14.0018X:</b>                  Ex d/ia [ia IIC Ga] IIB + H2 T6 to T1 Gb/Ga                  Ta = -40°C to +70°C                  IP66/67</p>	<p><b>Non- Incendive</b></p> <p><b>US/Canada:</b>                  Class I, II, III, Division 2, Group A, B, C, D, E, F, G, T4                  Class I, Zone 2 AEx ia/nA [ia Ga] IIC T4 Ga/Gc                  Class I, Zone 2 Ex ia/nA [ia Ga] IIC T4 Ga/Gc                  Ta = -40°C to +70°C                  Type 4X, IP67</p> <p><b>ATEX – FM14ATEX0042X:</b>                  II 1/3 G Ex ia/nA [ia Ga] IIC T4 Ga/Gc                  Ta = -15°C to +70°C                  IP67</p> <p><b>IEC – IECEx FMG 14.0018X:</b>                  Ex ia/nA [ia Ga] IIC T4 Ga/Gc                  Ta = -15°C to + 70°C                  IP66/67</p>
<p><b>Intrinsically Safe</b></p> <p><b>US/Canada:</b>                  Class I, II, III, Div 1, Group A, B, C, D, E, F, G, T4,                  Class I, Zone 0 AEx ia IIC T4 Ga                  Class I, Zone 0 Ex ia IIC T4 Ga                  Ta = -40°C to + 70°C                  Type 4X, IP67</p> <p><b>ATEX – FM14ATEX0041X:</b>                  II 1 G Ex ia IIC T4 Ga                  Ta = -40°C to +70°C                  IP67</p> <p><b>IEC – IECEx FMG 14.0018X:</b>                  Ex ia IIC T4 Ga                  Ta = -40°C to +70°C                  IP66/67</p>	<p><b>Dust Ignition Proof</b></p> <p><b>US/Canada:</b>                  Class II, III, Division 1, Group E, F and G, T4                  Ta = -40°C to +70°C                  Type 4X, IP67</p> <p><b>ATEX – FM14ATEX0041X:</b>                  II 1/2 D Ex ia/tb [ia Da] IIIC T85°C to T450°C Da/Db                  Ta = -15°C to +70°C                  IP67</p> <p><b>IEC – IECEx FMG 14.0018X:</b>                  Ex ia tb [ia Da] IIIC T75°C to T435°C Db                  Ex ia IIIC T75°C to T435°C Da                  Ta = -15°C to +70°C                  IP66/67</p>

The following approval standards are applicable:

FM3600:2011, FM3610:2010, FM3611:2004, FM3615:2006, FM3616:2011, FM3810:2005, ANSI/ISA60079-0:2013, ANSI/ISA 60079-1:2009, ANSI/ISA 60079-11:2013, ANSI/ISA 60079-15:2012, ANSI/ISA 60079-26:2011, NEMA 250:2003, ANSI/IEC 60529:2004, C22.2 No. 0.4:2009, C22.2 No. 0.5:2008, C22.2 No. 30:2007, C22.2 No. 94:2001, C22.2 No. 157:2012, C22.2 No. 213:2012, C22.2 No. 1010.1:2009, CAN/CSA 60079-0:2011, CAN/CSA 60079-1:2011, CAN/CSA 60079-11:2011, CAN/CSA 60079-15:2012, C22.2 No. 60529:2005, EN60079-0:2012, EN60079-1:2007, EN60079-11:2012, EN60079-15:2010, EN60079-26:2007, EN60079-31:2009, EN60529+A1:1991-2000, IEC60079-0:2011, IEC60079-1:2007, IEC60079-11:2011, IEC60079-15:2010, IEC60079-26:2006, IEC60079-31:2008

Lloyd's Register LR Type Approval - Marine, offshore and industrial applications for use in environmental categories ENV 1, 2, and 5 as defined in the Type Approval Test Specification No. 1 (2015).

Lloyd's Register Steamdrum Approval – EN 12953-9 and EN 12951-11

# AGENCY APPROVALS

---

## Special Conditions of Use

1. The enclosure contains aluminum and is considered to present a potential risk of ignition by impact or friction. Care must be taken during installation and use to prevent impact or friction.
2. The risk of electrostatic discharge shall be minimized at installation, following the directions given in the instructions.
3. Contact the original manufacturer for information on the dimensions of the flameproof joints.
4. For installation with ambient temperature of +70 °C, refer to the manufacturer's instructions for guidance on proper selection of conductors.
5. **WARNING—Explosion Hazard:** Do not disconnect equipment when flammable or combustible atmosphere is present.
6. For IEC and ATEX: To maintain the T1 to T6 temperature codes, care shall be taken to ensure the enclosure temperature does not exceed +70 °C.
7. For U.S. and Canada: To maintain the T4 temperature code, care shall be taken to ensure the enclosure temperature does not exceed +70 °C.
8. Temperature codes for the ratings Ex d/ia [ia IIC] IIB+H2 and Ex ia/tb [ia] IIIC are defined by the following table:

Process Temperature (PT)	Temperature Code-TCG (GAS)	Temperature Code-TCD (Dust)
Up to 75 °C	T6	TCD= PT+10K=85 °C
From 75 to 90 °C	T5	TCD= PT+10K=100 °C
From 90 to 120 °C	T4	TCD= PT+15K=135 °C
From 125 to 185 °C	T3	TCD= PT+15K=200 °C
From 185 to 285 °C	T2	TCD= PT+15K=300 °C
From 285 to 435 °C	T1	TCD= PT+15K=450 °C

## Agency Specifications – Explosion Proof Installation

**Factory Sealed:** This product has been approved by **Factory Mutual Research (FM)** as a **Factory Sealed device**.

**NOTE:** Factory Sealed: No Explosion Proof conduit fitting (EY seal) is required within 18" of the transmitter. However, an Explosion Proof conduit fitting (EY seal) is required between the hazardous and safe areas.

# MODEL NUMBER

## TRANSMITTER

 Models available for quick shipment, usually within one week after factory receipt of a complete purchase order, through the Expedite Ship Plan (ESP).

### 1 2 3 | BASIC MODEL NUMBER

7	0	6	ECLIPSE 4th Generation Guided Wave Radar (GWR) Level Transmitter
---	---	---	--

### 4 | POWER

5	24 VDC, Two-Wire
---	------------------

### 5 | SIGNAL OUTPUT

1	4–20 mA with HART
2	FOUNDATION fieldbus™ Communication
3	PROFIBUS PA Communication
4	Modbus Communication (8th Digit = 0 or 3 only)

### 6 | SAFETY OPTIONS

0	None – FOUNDATION fieldbus, PROFIBUS PA and Modbus only (5th digit = 2, 3 or 4)
2	SIL 2/3 Certified - HART only (5th digit = 1)

### 7 | ACCESSORIES/MOUNTING

0	No Digital Display or Keypad - Integral
1	No Digital Display or Keypad - 3-foot (1 meter) remote
2	No Digital Display or Keypad - 12-foot (3.6 meter) remote
A	Digital Display and Keypad - Integral
B	Digital Display and Keypad - 3-foot (1 meter) remote
C	Digital Display and Keypad - 12-foot (3.6 meter) remote

### 8 | CLASSIFICATION

0	General Purpose, Weatherproof (IP 67)
1	Intrinsically Safe (FM & CSA CL 1 Div 1, Grps A, B, C, D) (5th digit = 1 or 2)
3	Explosion-proof (FM & CSA CL 1 Div 1, Grps B, C, D)
A	Intrinsically Safe (ATEX/IEC Ex ia IIC T4) (5th digit = 1 or 2)
B	Flame-proof (ATEX/IEC Ex d ia IIC T6) (5th digit = 1 or 2)
C	Non-sparking (ATEX Ex n IIC T6) / Non-incendive (FM & CSA, CL 1 Div 2) (5th digit = 1 or 2)
D	Dust Ex (ATEX II) (5th digit = 1 or 2)

### 9 | HOUSING

1	Die-cast Aluminum, Dual-compartment, 45-degree
2	Investment Cast, Stainless Steel, Dual-compartment, 45-degree

### 10 | CONDUIT CONNECTION

0	½" NPT
1	M20
2	½" NPT with sunshade
3	M20 with sunshade



# DIMENSIONS

inches (mm)

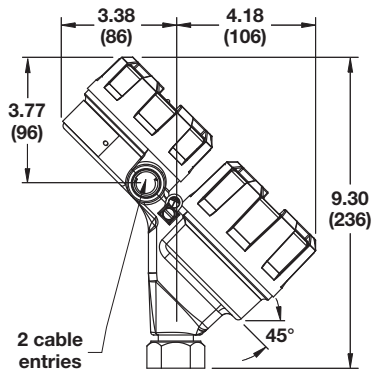

**Integral Electronics**

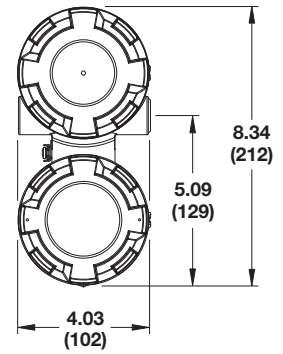

**Eclipse® Housing  
(45° View)**

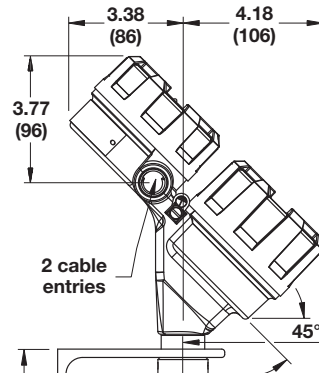
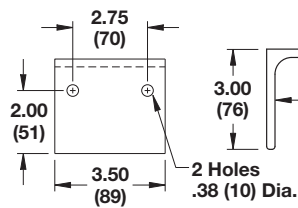

**Eclipse® Remote Configurations**

33 or 144  
(838 or 3650)

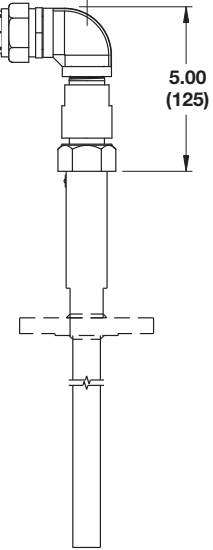

# ELECTRICAL WIRING

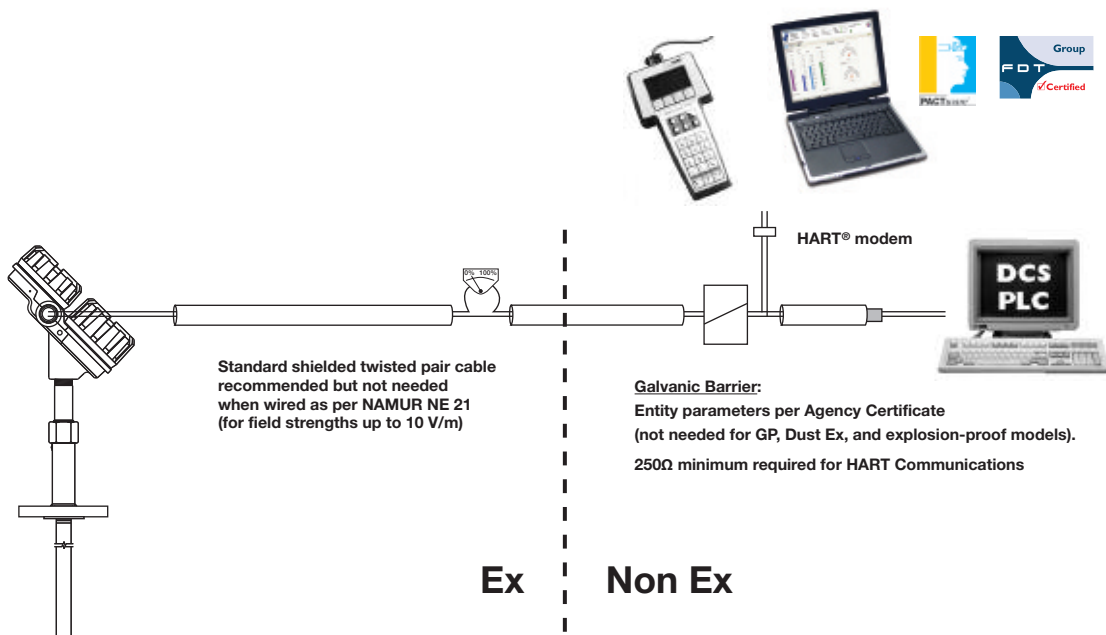



# MODEL NUMBER

## ENLARGED COAXIAL PROBE

 Models available for quick shipment, usually within one week after factory receipt of a complete purchase order, through the Expedite Ship Plan (ESP).

### 1 | TECHNOLOGY

7	ECLIPSE GWR Probes - Model 706
---	--------------------------------

### 2 | MEASUREMENT SYSTEM

A	English
C	Metric

### 3 | CONFIGURATION/STYLE (RIGID)

D	Enlarged Coaxial, High Temp/High Pressure: Overfill w/Glass Seal (+850 °F/+450 °C) — Available only with 10th digit N or D
P	Enlarged Coaxial, High Pressure: Overfill w/Glass Seal (+400 °F/+200 °C) — Available only with 10th digit N or D
T	Enlarged Coaxial, Overfill Standard O-Ring Seal (+400 °F/+200 °C) — NOT available with 10th digit N or D

### 4 5 | PROCESS CONNECTION – SIZE/TYPE (consult factory for other process connections)

Threaded

4 1	2" NPT Thread ①	4 2	2" BSP (G1) Thread ①
-----	-----------------	-----	----------------------

ASME Flanges

4 3	2" 150# ASME RF ①	5M	3" 1500# ASME RTJ
4 4	2" 300# ASME RF ①	5N	3" 2500# ASME RTJ
4 5	2" 600# ASME RF ①	6 3	4" 150# ASME RF
4 K	2" 600# ASME RTJ ①	6 4	4" 300# ASME RF
5 3	3" 150# ASME RF	6 5	4" 600# ASME RF
5 4	3" 300# ASME RF	6 6	4" 900# ASME RF
5 5	3" 600# ASME RF	6 7	4" 1500# ASME RF
5 6	3" 900# ASME RF	6 8	4" 2500# ASME RF
5 7	3" 1500# ASME RF	6K	4" 600# ASME RTJ
5 8	3" 2500# ASME RF	6L	4" 900# ASME RTJ
5K	3" 600# ASME RTJ	6M	4" 1500# ASME RTJ
5L	3" 900# ASME RTJ	6N	4" 2500# ASME RTJ

EN Flanges

D A	DN 50, PN 16	EN 1092-1 TYPE A ①	E H	DN 80, PN 320	EN 1092-1 TYPE B2
D B	DN 50, PN 25/40	EN 1092-1 TYPE A ①	E J	DN 80, PN 400	EN 1092-1 TYPE B2
D D	DN 50, PN 63	EN 1092-1 TYPE B2 ①	F A	DN 100, PN 16	EN 1092-1 TYPE A
D E	DN 50, PN 100	EN 1092-1 TYPE B2 ①	F B	DN 100, PN 25/40	EN 1092-1 TYPE A
E A	DN 80, PN 16	EN 1092-1 TYPE A	F D	DN 100, PN 63	EN 1092-1 TYPE B2
E B	DN 80, PN 25/40	EN 1092-1 TYPE A	F E	DN 100, PN 100	EN 1092-1 TYPE B2
E D	DN 80, PN 63	EN 1092-1 TYPE B2	F F	DN 100, PN 160	EN 1092-1 TYPE B2
E E	DN 80, PN 100	EN 1092-1 TYPE B2	F G	DN 100, PN 250	EN 1092-1 TYPE B2
E F	DN 80, PN 160	EN 1092-1 TYPE B2	F H	DN 100, PN 320	EN 1092-1 TYPE B2
E G	DN 80, PN 250	EN 1092-1 TYPE B2	F J	DN 100, PN 400	EN 1092-1 TYPE B2

Torque Tube Mating Flanges ②

T T	600# Fisher (249B/259B) in carbon steel – as per dimensions on page 18
T U	600# Fisher (249C) in stainless steel – as per dimensions on page 18
U T	600# Masoneilan flange in carbon steel – as per dimensions on page 18
U U	600# Masoneilan flange in stainless steel – as per dimensions on page 18

① Confirm mounting conditions/nozzle diameter to ensure sufficient clearance.  
② Always check dimensions if ASME/EN flanges are not used.

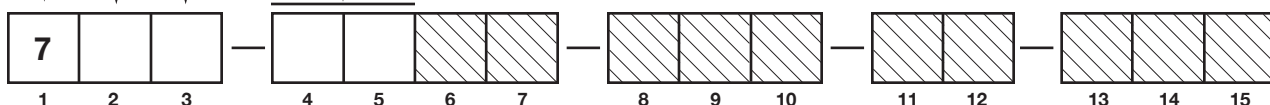

# MODEL NUMBER CONTINUED

## ENLARGED COAXIAL PROBE

### 6 | CONSTRUCTION CODES

0	Industrial
K	ASME B31.1
L	ASME B31.3
M	ASME B31.3 & NACE MR0175/MR0103 — NOT available with carbon steel flange
N	NACE MR0175/MR0103 — NOT available with carbon steel flange

### 7 | FLANGE OPTIONS — Offset flanges are available only with small coaxial probes

0	None
---	------

### 8 | MATERIAL OF CONSTRUCTION - FLANGE/NUT/ROD/INSULATION

A	316 SS/316L SS (Probe O.D. 1.75" (45mm))
B	Hastelloy C (Probe O.D. 1.93" (49mm))
C	Monel (Probe O.D. 1.93" (49mm))
R	316 SS/316L SS with Carbon Steel Flange (Probe O.D. 1.75" (45 mm))
S	Hastelloy C with Carbon Steel Flange (Probe O.D. 1.93" (49mm))
T	Monel with Carbon Steel Flange (Probe O.D. 1.93" (49mm))

### 9 | SPACER MATERIAL

1	TFE (+400 °F/+200 °C) — Available only with 3rd digit P or T — $\epsilon_r \geq 1.4$
2	PEEK HT — Available only with 3rd digit D (+650 °F/+345 °C) — $\epsilon_r \geq 1.4$
3	Ceramic (High Temp. >+800 °F/+425 °C) — Available only with 3rd digit D — $\epsilon_r \geq 2.0$
4	Celazole (+800 °F/+425 °C) — Available only with 3rd digit D — $\epsilon_r \geq 1.4$
5	None - with metal shorting rod — $\epsilon_r \geq 1.4$ — Future

### 10 | O-RING MATERIALS/SEAL OPTIONS

0	Viton® GFLT — Available only with 3rd digit T
2	Kalrez® 4079 — Available only with 3rd digit T
8	Aegis PF 128 (NACE) — Available only with 3rd digit T
A	Kalrez 6375 — Available only with 3rd digit T
B	HF Acid Probe — Available only with 3rd digit T and 8th digit C
D	None/Glass Ceramic Alloy (dual-seal design with annunciator fitting) — Available only with 3rd digit D or P
N	None/Glass Ceramic Alloy — Available only with 3rd digit D, P or S

### 11 | PROBE SIZE/ELEMENT TYPE/FLUSHING CONNECTION

0	Standard Enlarged Coaxial Probe
1	Standard Enlarged Coaxial Probe with Flushing Port

### 12 | SPECIAL OPTIONS — See page 36

0	Single Length Probe (Non-Segmented)
1	1-piece Enlarged Segmented Probe OD=2.5"(64mm)
2	2-piece Enlarged Segmented Probe OD=2.5"(64mm)
3	3-piece Enlarged Segmented Probe OD=2.5"(64mm)
4	4-piece Enlarged Segmented Probe OD=2.5"(64mm)
5	5-piece Enlarged Segmented Probe OD=2.5"(64mm)
6	6-piece Enlarged Segmented Probe OD=2.5"(64mm)

### 13 14 15 | INSERTION LENGTH

X X X	inches (012 – 396) cm (030 – 999)
-------	--------------------------------------

unit of measure determined by 2nd digit of model number

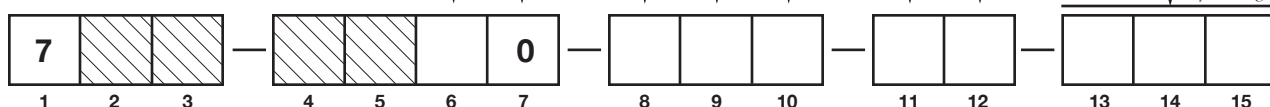

# MODEL NUMBER

## SMALL COAXIAL PROBE

 Models available for quick shipment, usually within one week after factory receipt of a complete purchase order, through the Expedite Ship Plan (ESP).

### 1 | TECHNOLOGY

7	ECLIPSE GWR Probes - Model 706
---	--------------------------------

### 2 | MEASUREMENT SYSTEM

A	English
C	Metric

### 3 | CONFIGURATION/STYLE (RIGID)

D	Small Coaxial, High Temp/High Pressure: Overfill w/Glass Seal (+850 °F/+450 °C) — Available only with 10th digit N or D
P	Small Coaxial, High Pressure: Overfill w/Glass Seal (+400 °F/+200 °C) — Available only with 10th digit N or D
S	Small Coaxial, Saturated Steam (+575/+650 °F [+300/+345 °C]), Max. Length=240" (610 cm) — Available only with 10th digit N, 9th digit 2 or 3
T	Small Coaxial, Overfill Standard O-Ring Seal (+400 °F/+200 °C) — NOT available with 10th digit N or D

### 4 5 | PROCESS CONNECTION – SIZE/TYPE (consult factory for other process connections)

Threaded

1 1	¾" NPT Thread ③	2 2	1" BSP (G1) Thread ③
4 1	2" NPT Thread — Available only with 3rd Digit D	4 2	2" BSP (G1) Thread — Available only with 3rd Digit D

ASME Flanges

2 3	1" 150# ASME RF ① ④	3 8	1½" 2500# ASME RF ④	5 3	3" 150# ASME RF	6 3	4" 150# ASME RF
2 4	1" 300# ASME RF ① ④	3 N	1½" 2500# ASME RTJ ④	5 4	3" 300# ASME RF	6 4	4" 300# ASME RF
2 5	1" 600# ASME RF ① ④	4 3	2" 150# ASME RF	5 5	3" 600# ASME RF	6 5	4" 600# ASME RF
2 K	1" 600# ASME RTJ ① ④	4 4	2" 300# ASME RF	5 6	3" 900# ASME RF	6 6	4" 900# ASME RF
3 3	1½" 150# ASME RF ④	4 5	2" 600# ASME RF	5 7	3" 1500# ASME RF	6 7	4" 1500# ASME RF
3 4	1½" 300# ASME RF ④	4 7	2" 900/1500# ASME RF	5 8	3" 2500# ASME RF	6 8	4" 2500# ASME RF
3 5	1½" 600# ASME RF ④	4 8	2" 2500# ASME RF	5 K	3" 600# ASME RTJ	6 K	4" 600# ASME RTJ
3 K	1½" 600# ASME RTJ ④	4 K	2" 600# ASME RTJ	5 L	3" 900# ASME RTJ	6 L	4" 900# ASME RTJ
3 7	1½" 900/1500# ASME RF ④	4 M	2" 900/1500# ASME RTJ	5 M	3" 1500# ASME RTJ	6 M	4" 1500# ASME RTJ
3 M	1½" 900/1500# ASME RTJ ④	4 N	2" 2500# ASME RTJ	5 N	3" 2500# ASME RTJ	6 N	4" 2500# ASME RTJ

EN Flanges

B B	DN 25, PN 16/25/40 EN 1092-1 TYPE A ① ④	E A	DN 80, PN 16 EN 1092-1 TYPE A
B C	DN 25, PN 63/100 EN 1092-1 TYPE B2 ① ④	E B	DN 80, PN 25/40 EN 1092-1 TYPE A
C B	DN 40, PN 16/25/40 EN 1092-1 TYPE A ④	E D	DN 80, PN 63 EN 1092-1 TYPE B2
C C	DN 40, PN 63/100 EN 1092-1 TYPE B2 ④	E E	DN 80, PN 100 EN 1092-1 TYPE B2
C F	DN 40, PN 160 EN 1092-1 TYPE B2 ④	E F	DN 80, PN 160 EN 1092-1 TYPE B2
C G	DN 40, PN 250 EN 1092-1 TYPE B2 ④	E G	DN 80, PN 250 EN 1092-1 TYPE B2
C H	DN 40, PN 320 EN 1092-1 TYPE B2 ④	E H	DN 80, PN 320 EN 1092-1 TYPE B2
C J	DN 40, PN 400 EN 1092-1 TYPE B2 ④	E J	DN 80, PN 400 EN 1092-1 TYPE B2
D A	DN 50, PN 16 EN 1092-1 TYPE A	F A	DN 100, PN 16 EN 1092-1 TYPE A
D B	DN 50, PN 25/40 EN 1092-1 TYPE A	F B	DN 100, PN 25/40 EN 1092-1 TYPE A
D D	DN 50, PN 63 EN 1092-1 TYPE B2	F D	DN 100, PN 63 EN 1092-1 TYPE B2
D E	DN 50, PN 100 EN 1092-1 TYPE B2	F E	DN 100, PN 100 EN 1092-1 TYPE B2
D F	DN 50, PN 160 EN 1092-1 TYPE B2	F F	DN 100, PN 160 EN 1092-1 TYPE B2
D G	DN 50, PN 250 EN 1092-1 TYPE B2	F G	DN 100, PN 250 EN 1092-1 TYPE B2
D H	DN 50, PN 320 EN 1092-1 TYPE B2	F H	DN 100, PN 320 EN 1092-1 TYPE B2
D J	DN 50, PN 400 EN 1092-1 TYPE B2	F J	DN 100, PN 400 EN 1092-1 TYPE B2

Torque Tube Mating Flanges ②

T T	600# Fisher (249B/259B) in carbon steel – as per dimensions on page 18
T U	600# Fisher (249C) in stainless steel – as per dimensions on page 18
U T	600# Masoneilan flange in carbon steel – as per dimensions on page 18
U U	600# Masoneilan flange in stainless steel – as per dimensions on page 18

- ① Confirm mounting conditions/nozzle diameter to ensure sufficient clearance.
- ② Always check dimensions if ASME/EN flanges are not used.
- ③ Not available with 3rd digit 'D'
- ④ Not available with 3rd Digit D or P

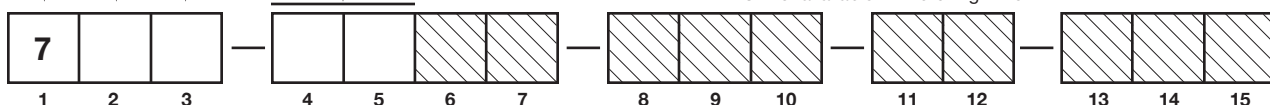

# MODEL NUMBER CONTINUED

## SMALL COAXIAL PROBE

### 6 | CONSTRUCTION CODES

0	Industrial
K	ASME B31.1 — NOT available with 4th digits T or U
L	ASME B31.3
M	ASME B31.3 & NACE MR0175/MR0103 — NOT available with carbon steel flange
N	NACE MR0175/MR0103 — NOT available with carbon steel flange

### 7 | FLANGE OPTIONS — Offset flanges are available only with small coaxial probes

0	None
1	Offset (For use with AURORA) — 4" Available only with 3rd digit P, S or T
2	Offset with 1/2" NPT Vent (For use with AURORA) — 4" Available only with 3rd digit P, S or T
3	Offset with 3/8" NPT Vent (For use with AURORA) — 4" Available only with 3rd digit P, S or T

### 8 | MATERIAL OF CONSTRUCTION - FLANGE/NUT/ROD/INSULATION

A	316 SS/316L SS
B	Hastelloy C
C	Monel — NOT available with 3rd digit S
R	316 SS/316L SS with Carbon Steel Flange
S	Hastelloy C with Carbon Steel Flange
T	Monel with Carbon Steel Flange — NOT available with 3rd digit S

### 9 | SPACER MATERIAL

1	TFE (+400 °F/+200 °C) — Available only with 3rd digit P or T — $\epsilon_r \geq 1.4$
2	PEEK HT — Available only with 3rd digit D — $\epsilon_r \geq 1.4$ (+650 °F/+345 °C) or S (+575 °F/+300 °C)
3	Ceramic (Temp. >+650 °F/+345 °C) — Available only with 3rd digit D with $\epsilon_r \geq 2.0$ or with 3rd digit S *
5	None - Single bottom metal spacer — Available only with 3rd digit S *

\* Not available with 5th digit 1 or 2.

### 10 | O-RING MATERIALS/SEAL OPTIONS

0	Viton® GFLT — Available only with 3rd digit T
2	Kalrez® 4079 — Available only with 3rd digit T
8	Aegis PF 128 (NACE) — Available only with 3rd digit T
A	Kalrez 6375 — Available only with 3rd digit T
B	HF Acid Probe — Available only with 3rd digit T and 8th digit C
D	None/Glass Ceramic Alloy (dual-seal design with annunciator fitting) — Available only with 3rd digit D or P
N	None/Glass Ceramic Alloy — Available only with 3rd digit D, P or S

### 11 | PROBE SIZE/ELEMENT TYPE/FLUSHING CONNECTION

2	Small Coaxial (0.875 inches/22 mm)
A	Medium Coaxial (1.25 inches/32 mm) — Available only with 3rd digit S ⑤
B	Large Coaxial (1.62 inches/42 mm) — Available only with 3rd digit S ⑥

⑤ 96 inches (244 cm) maximum length  
 ⑥ 120 inches (305 cm) maximum length

### 12 | SPECIAL OPTIONS

0	Single Length Probe (Non-Segmented)
---	-------------------------------------

### 13 14 15 | INSERTION LENGTH

X X X	inches (012 – 240) cm (030 – 610)
-------	--------------------------------------

unit of measure determined by 2nd digit of model number

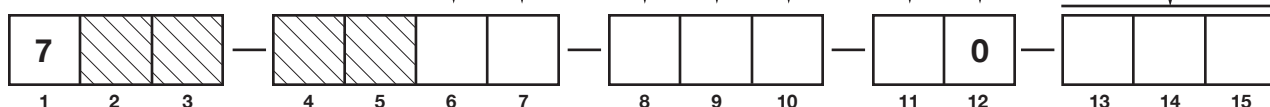

# MODEL NUMBER

## CAGED PROBE

Models available for quick shipment, usually within one week after factory receipt of a complete purchase order, through the Expedite Ship Plan (ESP).

### 1 | TECHNOLOGY

7	ECLIPSE GWR Probes - Model 706
---	--------------------------------

### 2 | MEASUREMENT SYSTEM

A	English
C	Metric

### 3 | CONFIGURATION/STYLE (RIGID)

G	Overfill Caged Rigid Probe for use in chambers +400 °F (+200 °C) — Available only with 2", 3" and 4" flanges
J	Overfill Caged High Temp/High Pressure Probe with Glass Seal for use in chambers +850 °F (+450 °C) Available only with 2", 3" and 4" flanges
L	Overfill Caged High Pressure Probe with Glass Seal for use in chambers +400 °F (+200 °C) Available only with 2", 3" and 4" flanges

### 4 5 | PROCESS CONNECTION – SIZE/TYPE (consult factory for other process connections) ①

ASME Flanges

4 3	2" 150# ASME RF	5 4	3" 300# ASME RF	6 3	4" 150# ASME RF
4 4	2" 300# ASME RF	5 5	3" 600# ASME RF	6 4	4" 300# ASME RF
4 5	2" 600# ASME RF	5 6	3" 900# ASME RF	6 5	4" 600# ASME RF
4 7	2" 900/1500# ASME RF	5 7	3" 1500# ASME RF	6 6	4" 900# ASME RF
4 8	2" 2500# ASME RF	5 8	3" 2500# ASME RF	6 7	4" 1500# ASME RF
4 K	2" 600# ASME RTJ	5 K	3" 600# ASME RTJ	6 8	4" 2500# ASME RF
4 M	2" 900/1500# ASME RTJ	5 L	3" 900# ASME RTJ	6 K	4" 600# ASME RTJ
4 N	2" 2500# ASME RTJ	5 M	3" 1500# ASME RTJ	6 L	4" 900# ASME RTJ
5 3	3" 150# ASME RF	5 N	3" 2500# ASME RTJ	6 M	4" 1500# ASME RTJ
				6 N	4" 2500# ASME RTJ

EN Flanges

D A	DN 50, PN 16	EN 1092-1 TYPE A	E F	DN 80, PN 160	EN 1092-1 TYPE B2
D B	DN 50, PN 25/40	EN 1092-1 TYPE A	E G	DN 80, PN 250	EN 1092-1 TYPE B2
D D	DN 50, PN 63	EN 1092-1 TYPE B2	E H	DN 80, PN 320	EN 1092-1 TYPE B2
D E	DN 50, PN 100	EN 1092-1 TYPE B2	E J	DN 80, PN 400	EN 1092-1 TYPE B2
D F	DN 50, PN 160	EN 1092-1 TYPE B2	F A	DN 100, PN 16	EN 1092-1 TYPE A
D G	DN 50, PN 250	EN 1092-1 TYPE B2	F B	DN 100, PN 25/40	EN 1092-1 TYPE A
D H	DN 50, PN 320	EN 1092-1 TYPE B2	F D	DN 100, PN 63	EN 1092-1 TYPE B2
D J	DN 50, PN 400	EN 1092-1 TYPE B2	F E	DN 100, PN 100	EN 1092-1 TYPE B2
E A	DN 80, PN 16	EN 1092-1 TYPE A	F F	DN 100, PN 160	EN 1092-1 TYPE B2
E B	DN 80, PN 25/40	EN 1092-1 TYPE A	F G	DN 100, PN 250	EN 1092-1 TYPE B2
E D	DN 80, PN 63	EN 1092-1 TYPE B2	F H	DN 100, PN 320	EN 1092-1 TYPE B2
E E	DN 80, PN 100	EN 1092-1 TYPE B2	F J	DN 100, PN 400	EN 1092-1 TYPE B2

Torque Tube Mating Flanges ②

T T	600# Fisher (249B/259B) in carbon steel – as per dimensions on page 18
T U	600# Fisher (249C) in stainless steel – as per dimensions on page 18
U T	600# Masoneilan flange in carbon steel – as per dimensions on page 18
U U	600# Masoneilan flange in stainless steel – as per dimensions on page 18

① Confirm mounting conditions/nozzle diameter to ensure sufficient clearance.  
 ② Always check dimensions if ASME/EN flanges are not used.

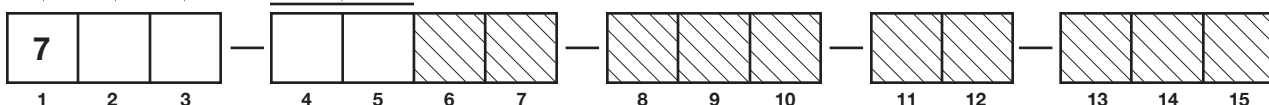

# MODEL NUMBER CONTINUED

## CAGED PROBE

### 6 | CONSTRUCTION CODES

0	Industrial
K	ASME B31.1
L	ASME B31.3
M	ASME B31.3 & NACE MR0175/MR0103 — NOT available with carbon steel flange
N	NACE MR0175/MR0103 — NOT available with carbon steel flange

### 7 | FLANGE OPTIONS

0	None
1	Offset (For use with AURORA) — 4" Available only with 3rd digit G and J and 4th digit 6
2	Offset with 1/2" NPT Vent (For use with AURORA) — 4" Available only with 3rd digit G and J and 4th digit 6
3	Offset with 3/4" NPT Vent (For use with AURORA) — 4" Available only with 3rd digit G and J and 4th digit 6

### 8 | MATERIAL OF CONSTRUCTION - MFG/NUT/ROD/INSULATION

A	316 SS/316L SS
B	Hastelloy C
C	Monel
R	316 SS/316L SS with Carbon Steel Flange
S	Hastelloy C with Carbon Steel Flange
T	Monel with Carbon Steel Flange

### 9 | SPACER MATERIAL

2	PEEK HT (+650 °F/+345 °C)
3	Ceramic (High Temp.>+800 °F/+425 °C) — Available only with 3rd digit J
4	Celazole® (+800 °F/+425 °C) — Available only with 3rd digit J

### 10 | O-RING MATERIALS/SEAL OPTIONS

0	Viton® GFLT — NOT available with 3rd digit J or L
2	Kalrez 4079 — NOT available with 3rd digit J or L
8	Aegis PF 128 (NACE) — NOT available with 3rd digit J or L
A	Kalrez 6375 — NOT available with 3rd digit J or L
B	HF Acid Probe — Available only with 3rd digit G and 8th digit C
D	None/Glass Ceramic Alloy (Dual Seal Design with annunciator fitting) — NOT available with 3rd digit G
N	None/Glass Ceramic Alloy — NOT available with 3rd digit G

### 11 | PROBE SIZE/ELEMENT TYPE/FLUSHING CONNECTION

0	None
---	------

### 12 | SPECIAL OPTIONS — See page 36

1	Single Length Removable Probe
2	2-piece Segmented Probe
3	3-piece Segmented Probe
4	4-piece Segmented Probe

### 13 14 15 | INSERTION LENGTH

X X X	inches (012 – 288) cm (030 – 732)
-------	--------------------------------------

unit of measure determined by 2nd digit of model number

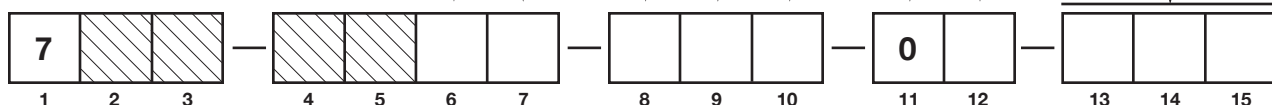

# MODEL NUMBER

## SINGLE ROD RIGID PROBE

Models available for quick shipment, usually within one week after factory receipt of a complete purchase order, through the Expedite Ship Plan (ESP).

### 1 | TECHNOLOGY

7	ECLIPSE GWR Probes - Model 706
---	--------------------------------

### 2 | MEASUREMENT SYSTEM

A	English
C	Metric

### 3 | CONFIGURATION/STYLE (RIGID)

F	Single Rod, Standard (+400 °F/200 °C) for in-tank applications — NOT available with 10th digit N or D
M	Single Rod, High Pressure Probe with glass seal (+400 °F/+200 °C), for in-tank applications — Available only with 10th digit N or D
N	Single Rod, High Temp/High Pressure with glass seal (+850 °F/+450 °C), for in-tank applications — Available only with 10th digit N or D

### 4 5 | PROCESS CONNECTION – SIZE/TYPE (consult factory for other process connections) ①

Threaded

2 1	1" NPT Thread ②
4 1	2" NPT Thread

2 2	1" BSP (G1) Thread ②
4 2	2" BSP (G1) Thread

ASME Flanges

3 3	1½" 150# ASME RF ① ③
3 4	1½" 300# ASME RF ① ③
3 5	1½" 600# ASME RF ① ③
4 3	2" 150# ASME RF ①
4 4	2" 300# ASME RF ①
4 5	2" 600# ASME RF ①
4 7	2" 900/1500# ASME RF
4 8	2" 2500# ASME RF
4 K	2" 600# ASME RTJ
4 M	2" 900/1500# ASME RTJ

4 N	2" 2500# ASME RTJ
5 3	3" 150# ASME RF
5 4	3" 300# ASME RF
5 5	3" 600# ASME RF
5 6	3" 900# ASME RF
5 7	3" 1500# ASME RF
5 8	3" 2500# ASME RF
5 K	3" 600# ASME RTJ
5 L	3" 900# ASME RTJ
5 M	3" 1500# ASME RTJ

5 N	3" 2500# ASME RTJ
6 3	4" 150# ASME RF
6 4	4" 300# ASME RF
6 5	4" 600# ASME RF ④
6 6	4" 900# ASME RF ④
6 7	4" 1500# ASME RF ④
6 8	4" 2500# ASME RF ④
6 K	4" 600# ASME RTJ ④
6 L	4" 900# ASME RTJ ④
6 M	4" 1500# ASME RTJ ④
6 N	4" 2500# ASME RTJ ④

EN Flanges

C B	DN 40, PN 16/25/40 EN 1092-1 TYPE A
C C	DN 40, PN 63/100 EN 1092-1 TYPE B2
C F	DN 40, PN 160 EN 1092-1 TYPE B2
C G	DN 40, PN 250 EN 1092-1 TYPE B2
D A	DN 50, PN 16 EN 1092-1 TYPE A ①
D B	DN 50, PN 25/40 EN 1092-1 TYPE A ①
D D	DN 50, PN 63 EN 1092-1 TYPE B2 ①
D E	DN 50, PN 100 EN 1092-1 TYPE B2 ①
D F	DN 50, PN 160 EN 1092-1 TYPE B2 ④
D G	DN 50, PN 250 EN 1092-1 TYPE B2 ④
D H	DN 50, PN 320 EN 1092-1 TYPE B2 ④
D J	DN 50, PN 400 EN 1092-1 TYPE B2 ④
E A	DN 80, PN 16 EN 1092-1 TYPE A ①
E B	DN 80, PN 25/40 EN 1092-1 TYPE A

E D	DN 80, PN 63 EN 1092-1 TYPE B2
E E	DN 80, PN 100 EN 1092-1 TYPE B2
E F	DN 80, PN 160 EN 1092-1 TYPE B2 ④
E G	DN 80, PN 250 EN 1092-1 TYPE B2 ④
E H	DN 80, PN 320 EN 1092-1 TYPE B2 ④
E J	DN 80, PN 400 EN 1092-1 TYPE B2 ④
F A	DN 100, PN 16 EN 1092-1 TYPE A
F B	DN 100, PN 25/40 EN 1092-1 TYPE A
F D	DN 100, PN 63 EN 1092-1 TYPE B2
F E	DN 100, PN 100 EN 1092-1 TYPE B2
F F	DN 100, PN 160 EN 1092-1 TYPE B2 ④
F G	DN 100, PN 250 EN 1092-1 TYPE B2 ④
F H	DN 100, PN 320 EN 1092-1 TYPE B2 ④
F J	DN 100, PN 400 EN 1092-1 TYPE B2 ④

- ① Confirm mounting conditions/nozzle diameter to ensure sufficient clearance.
- ② Not available with 3rd Digit N or 8th Digit P
- ③ Not available with 3rd Digit M or N
- ④ Available only with 3rd Digit M or N

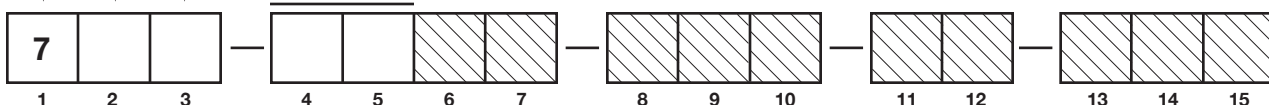

# MODEL NUMBER CONTINUED

## SINGLE ROD RIGID PROBE

### 6 | CONSTRUCTION CODES

0	Industrial
K	ASME B31.1
L	ASME B31.3
M	ASME B31.3 & NACE MR0175/MR0103 — NOT available with carbon steel flange
N	NACE MR0175/MR0103 — NOT available with carbon steel flange

### 7 | FLANGE OPTIONS

0	None
---	------

### 8 | MATERIAL OF CONSTRUCTION - MFG/NUT/ROD/INSULATION

A	316 SS/316L SS
B	Hastelloy C
C	Monel
F	Faced Flange, PFA coated wetted surfaces — Available only with 3rd digit F
P	PFA coated rod — Available only with 3rd digit F
R	316 SS/316L SS with Carbon Steel Flange
S	Hastelloy C with Carbon Steel Flange
T	Monel with Carbon Steel Flange

### 9 | SPACER MATERIAL

0	None — NOT available with 3rd Digit N
2	PEEK HT (+650 °F/+345 °C) — Available only with 3rd digit N
3	Ceramic (High Temp.>+800 °F/+425 °C) — Available only with 3rd digit N
4	Celazole® (+800 °F/+425 °C) — Available only with 3rd digit N

### 10 | O-RING MATERIALS/SEAL OPTIONS

0	Viton® GFLT — NOT available with 3rd digit M or N
2	Kalrez 4079 — NOT available with 3rd digit M or N
8	Aegis PF 128 (NACE) — NOT available with 3rd digit M or N
A	Kalrez 6375 — NOT available with 3rd digit M or N
D	None/Glass Ceramic Alloy Dual Seal with annunciator fitting — NOT available with 3rd digit F
N	None/Glass Ceramic Alloy Dual Seal — NOT available with 3rd digit F

### 11 | PROBE SIZE/ELEMENT TYPE/FLUSHING CONNECTION

0	Standard Single Rod
---	---------------------

### 12 | SPECIAL OPTIONS

0	Non-Removable Rod Available only with PFA Coated Probes(8th digit F or P)
1	Removable Rod Not available with PFA Coated Probes(8th Digit F or P)
2	Two-piece segmented probe
3	Three-piece segmented probe
4	Four-piece segmented probe
5	Five-piece segmented probe
6	Six-piece segmented probe

### 13 14 15 | INSERTION LENGTH

X X X	inches (012 – 288) cm (030 – 732) maximum 240 inches (610 cm) when 8th digit = F or P
-------	--





# MODEL NUMBER

## SINGLE FLEXIBLE PROBE

Models available for quick shipment, usually within one week after factory receipt of a complete purchase order, through the Expedite Ship Plan (ESP).

### 1 | TECHNOLOGY

7	ECLIPSE GWR Probes - Model 706
---	--------------------------------

### 2 | MEASUREMENT SYSTEM

A	English
C	Metric

### 3 | SPECIALTY FLEXIBLE PROBES

1	Single Cable Flexible standard for in-tank applications (+400 °F/+200 °C)
2	Single Cable Flexible Light Duty Bulk Solids
3	Single Cable Flexible HP for in-tank applications (+400 °F/+200 °C)
4	Single Cable Flexible standard for chamber applications (+400 °F/+200 °C) — (Future)
6	Single Cable Flexible HTHP for chamber applications (+850 °F/+450 °C)

### 4 5 | PROCESS CONNECTION – SIZE/TYPE (consult factory for other process connections)

Threaded

4 1	2" NPT Thread (not available with the 7y6)	4 2	2" BSP (G1) Thread (not available with the 7y6)
-----	--	-----	---

ASME Flanges

4 3	2" 150# ASME RF ①	5 3	3" 150# ASME RF	6 3	4" 150# ASME RF
4 4	2" 300# ASME RF ①	5 4	3" 300# ASME RF	6 4	4" 300# ASME RF
4 5	2" 600# ASME RF ①	5 5	3" 600# ASME RF	6 5	4" 600# ASME RF
4 7	2" 900/1500# ASME RF	5 6	3" 900# ASME RF	6 6	4" 900# ASME RF ②
4 8	2" 2500# ASME RF	5 7	3" 1500# ASME RF	6 7	4" 1500# ASME RF ②
4 K	2" 600# ASME RTJ	5 8	3" 2500# ASME RF	6 8	4" 2500# ASME RF ②
4 M	2" 900/1500# ASME RTJ	5 K	3" 600# ASME RTJ	6 K	4" 600# ASME RTJ ②
4 N	2" 2500# ASME RTJ	5 L	3" 900# ASME RTJ	6 L	4" 900# ASME RTJ ②
		5 M	3" 1500# ASME RTJ	6 M	4" 1500# ASME RTJ ②
		5 N	3" 2500# ASME RTJ	6 N	4" 2500# ASME RTJ ②

EN Flanges

D A	DN 50, PN 16	EN 1092-1 TYPE A ①	E F	DN 80, PN 160	EN 1092-1 TYPE B2 ②
D B	DN 50, PN 25/40	EN 1092-1 TYPE A ①	E G	DN 80, PN 250	EN 1092-1 TYPE B2 ②
D D	DN 50, PN 63	EN 1092-1 TYPE B2 ①	E H	DN 80, PN 320	EN 1092-1 TYPE B2 ②
D E	DN 50, PN 100	EN 1092-1 TYPE B2 ①	E J	DN 80, PN 400	EN 1092-1 TYPE B2 ②
D F	DN 50, PN 160	EN 1092-1 TYPE B2 ②	F A	DN 100, PN 16	EN 1092-1 TYPE A
D G	DN 50, PN 250	EN 1092-1 TYPE B2 ②	F B	DN 100, PN 25/40	EN 1092-1 TYPE A
D H	DN 50, PN 320	EN 1092-1 TYPE B2 ②	F D	DN 100, PN 63	EN 1092-1 TYPE B2
D J	DN 50, PN 400	EN 1092-1 TYPE B2 ②	F E	DN 100, PN 100	EN 1092-1 TYPE B2
E A	DN 80, PN 16	EN 1092-1 TYPE A ①	F F	DN 100, PN 160	EN 1092-1 TYPE B2 ②
E B	DN 80, PN 25/40	EN 1092-1 TYPE A	F G	DN 100, PN 250	EN 1092-1 TYPE B2 ②
E D	DN 80, PN 63	EN 1092-1 TYPE B2	F H	DN 100, PN 320	EN 1092-1 TYPE B2 ②
E E	DN 80, PN 100	EN 1092-1 TYPE B2	F J	DN 100, PN 400	EN 1092-1 TYPE B2 ②

① Confirm mounting conditions/nozzle diameter to ensure sufficient clearance.  
 ② Available only with 3rd Digit 3 or 6

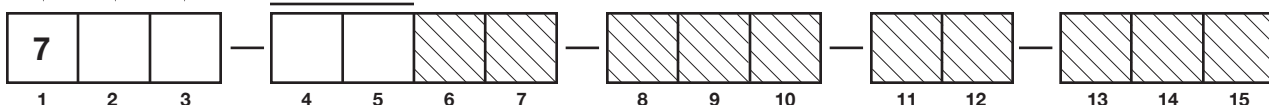

# MODEL NUMBER CONTINUED

## SINGLE FLEXIBLE PROBE

### 6 | CONSTRUCTION CODES

0	Industrial
---	------------

### 7 | FLANGE OPTIONS

0	None
---	------

### 8 | MATERIAL OF CONSTRUCTION - MFG/NUT/ROD/INSULATION

A	316 SS/316L SS
F	Faced Flange, PFA Coated Wetted Surfaces — Available only with 3rd digit 1
R	316 SS/316L SS with Carbon Steel Flange

### 9 | SPACER/WEIGHT MATERIAL

0	No Spacer — Not available with 3rd digit 3
1	PTFE Spacer — Available only with 3rd digit 3
4	Celazole® Spacer — Available only with 3rd digit 6
5	Metal Weight — Available only with 3rd digit 3

### 10 | O-RING MATERIALS/SEAL OPTIONS

0	Viton® GFLT
2	Kalrez 4079
8	Aegis PF 128 (NACE)
A	Kalrez 6375
D	Glass Ceramic Alloy Dual Seal with annunciator fitting — Available only with 3rd digit 3 or 6
N	None/Glass Ceramic Alloy Dual Seal — Available only with 3rd digit 3 or 6

### 11 | PROBE SIZE/ELEMENT TYPE/FLUSHING CONNECTION

3	Flexible Cable Probe
---	----------------------

### 12 | SPECIAL OPTIONS

0	Non-removable Probe Cable Available only with 3rd digit 2 or 8th digit F
1	Removable Single-piece Probe Cable Available only with 3rd digit 1, 3 and 6

### 13 14 15 | INSERTION LENGTH

X X X	feet (003 – 100) meters (001 – 030)
-------	--

unit of measure determined by 2nd digit of model number

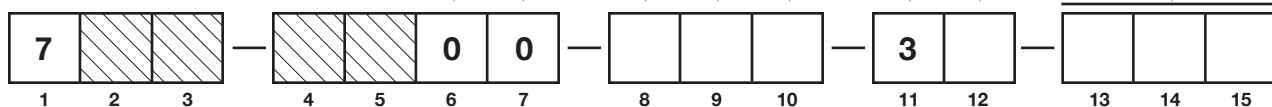

# MODEL NUMBER

## TWIN FLEXIBLE PROBE

 Models available for quick shipment, usually within one week after factory receipt of a complete purchase order, through the Expedite Ship Plan (ESP).

### 1 | TECHNOLOGY

7	ECLIPSE GWR Probes - Model 706
---	--------------------------------

### 2 | MEASUREMENT SYSTEM

A	English
C	Metric

### 3 | SPECIALTY FLEXIBLE PROBES

5	Twin Flexible Light Duty Bulk Solids with FEP Webbing
7	Twin Flexible - 316 SS with FEP Webbing

### 4 5 | PROCESS CONNECTION – SIZE/TYPE (consult factory for other process connections)

Threaded ①

2 1	1" NPT Thread (7yF and 7yM only)
4 1	2" NPT Thread

2 2	1" BSP (G1) Thread (7yF and 7yM only)
4 2	2" BSP (G1) Thread

ASME Flanges

5 3	3"	150 lbs. ASME RF
5 4	3"	300 lbs. ASME RF
5 5	3"	600 lbs. ASME RF
6 3	4"	150 lbs. ASME RF
6 4	4"	300 lbs. ASME RF
6 5	4"	600 lbs. ASME RF

EN Flanges

E A	DN 80, PN 16	EN 1092-1 TYPE A
E B	DN 80, PN 25/40	EN 1092-1 TYPE A
E D	DN 80, PN 63	EN 1092-1 TYPE B2
E E	DN 80, PN 100	EN 1092-1 TYPE B2
F A	DN 100, PN 16	EN 1092-1 TYPE A
F B	DN 100, PN 25/40	EN 1092-1 TYPE A
F D	DN 100, PN 63	EN 1092-1 TYPE B2
F E	DN 100, PN 100	EN 1092-1 TYPE B2

① Confirm mounting conditions/nozzle diameter to ensure sufficient clearance.

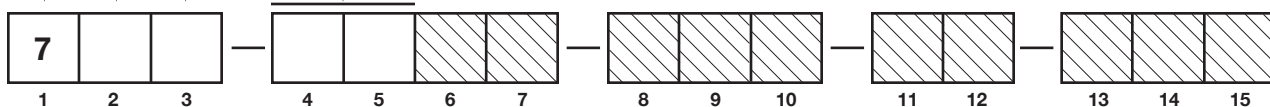

# MODEL NUMBER CONTINUED

## TWIN FLEXIBLE PROBE

### 6 | CONSTRUCTION CODES

0	Industrial
---	------------

### 7 | FLANGE OPTIONS

0	None
---	------

### 8 | MATERIAL OF CONSTRUCTION - MFG/NUT/ROD/INSULATION

A	316 SS/316L SS
R	316 SS/316L SS with Carbon Steel Flange

### 9 | SPACER MATERIAL

0	None
---	------

### 10 | O-RING MATERIALS/SEAL OPTIONS

0	Viton® GFLT
2	Kalrez 4079 — Available only with 3rd digit 7
8	Aegis PF 128 (NACE) — Available only with 3rd digit 7
A	Kalrez 6375 — Available only with 3rd digit 7

### 11 | PROBE SIZE/ELEMENT TYPE/FLUSHING CONNECTION

3	Flexible Cable Probe
---	----------------------

### 12 | SPECIAL OPTIONS

0	None
---	------

### 13 14 15 | INSERTION LENGTH

X X X	feet (003 – 100) meters (001 – 030)
-------	--

unit of measure determined by 2nd digit of model number

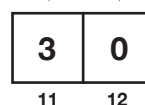
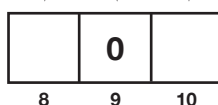
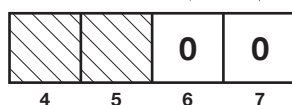
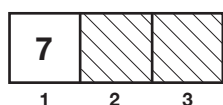

# SEGMENTED PROBE OPTIONS

## 12th DIGIT OF MODEL NUMBER

Probe Model	One Segment	Two Segments	Three Segments	Four Segments	Five Segments	Six Segments
Coaxial Models 7yD, 7yP and 7yT (Enlarged versions only) (3", DN 80 Process Connections and larger)	24 – 72" (60 – 182 cm)	48 – 144" (120 – 365 cm)	72 – 216" (180 – 548 cm)	96 – 288" (240 – 731 cm)	120 – 360" (305 – 914 cm)	144 – 396" (365 – 999 cm)
Caged Models 7yG, 7yL and 7yJ	12 – 120" (30 – 305 cm)	24 – 240" (60 – 610 cm)	36 – 288" (90 – 732 cm)	48 – 288" (120 – 732 cm)	Not Available	Not Available

NOTE: Segments will be evenly divided over the length of the probe.

# COAXIAL PROBE DIMENSIONS

INCHES (mm)

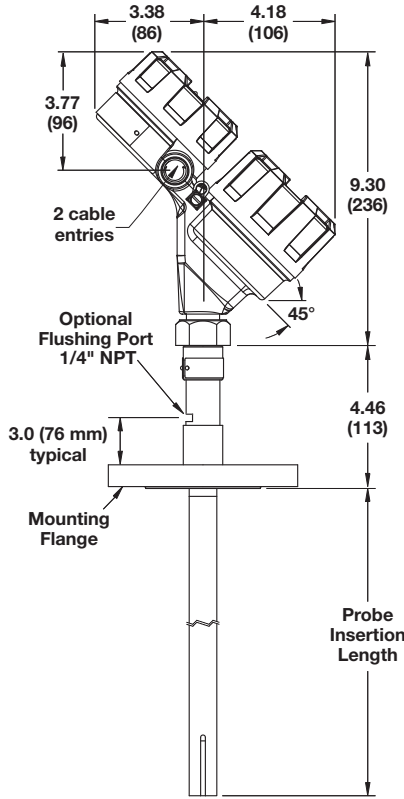

**Model 7yT**  
with flanged connection

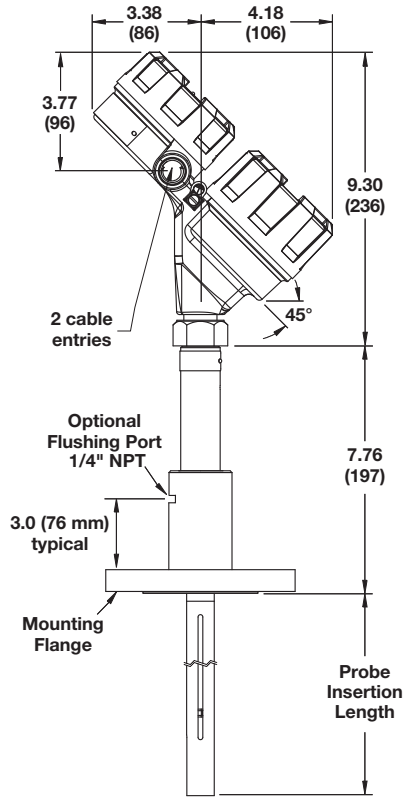

**Model 7yP**  
with flanged connection

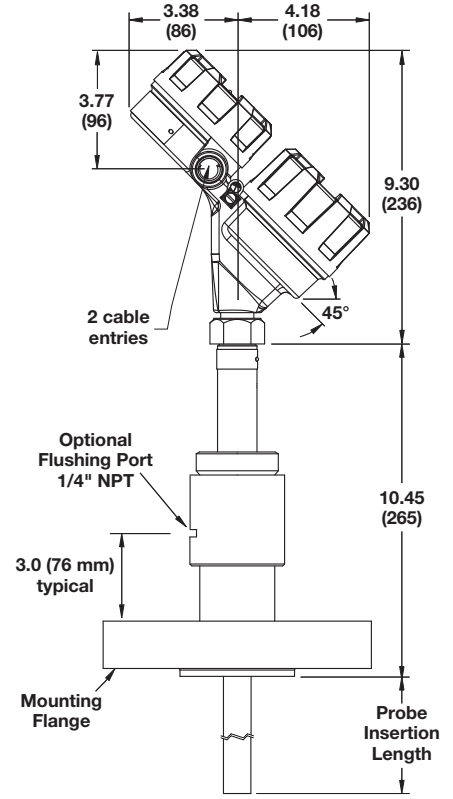

**Model 7yD**  
with flanged connection

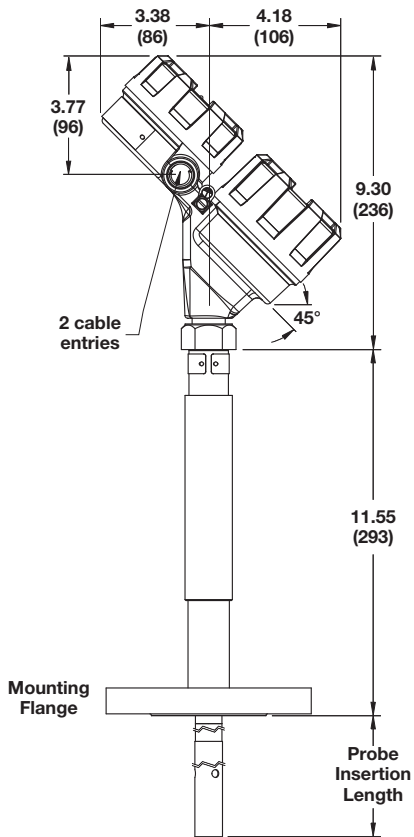

**Model 7yS**  
with flanged connection

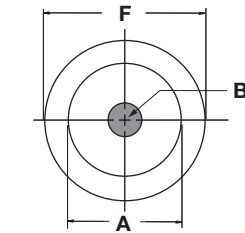

**Model 7yS**  
Coaxial GWR Probe,  
End View

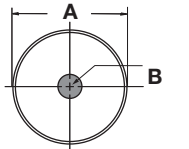

Coaxial GWR Probe,  
End View

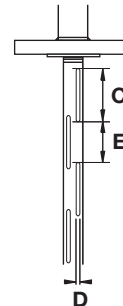

Coaxial Probe Slots

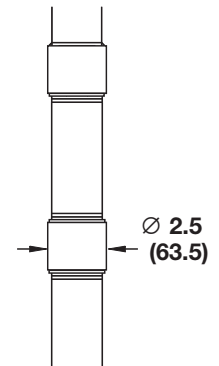

Segmented Enlarged  
Coaxial Probe

**Inches (mm)**

Dim.	Small Diameter	Medium Diameter	Large Diameter	Enlarged (standard)
<b>A</b>	0.88 (22.5)	1.25 (31.75)	1.62 (41.1)	1.75 (45) - SST 1.92 (49) - HC and Monel
<b>B</b>	0.31 (8)	0.38 (10) maximum	0.50 (13) max.	0.63 (16) maximum
<b>C</b>	4.08 (100)	6.05 (153)	6.05 (153)	6.05 (153)
<b>D</b>	0.15 (4)	0.30 (8)	0.30 (8)	0.30 (8)
<b>E</b>	3.78 (96)	5.45 (138)	5.45 (138)	5.45 (138)
<b>F</b>	1.25 (31.75)	—	—	—

# CAGED PROBE DIMENSIONS

INCHES (mm)

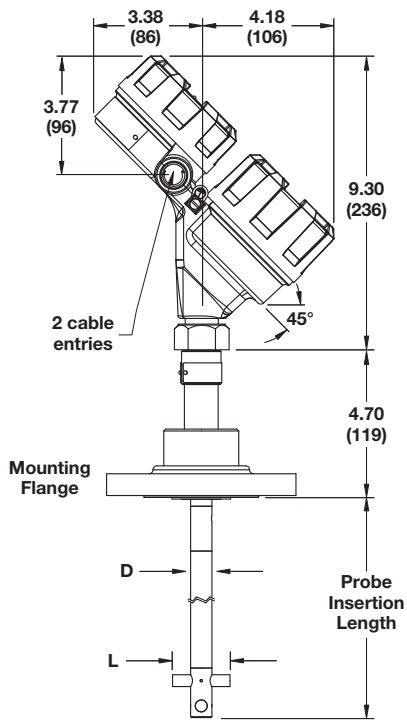

**Model 7yG**  
with flanged connection

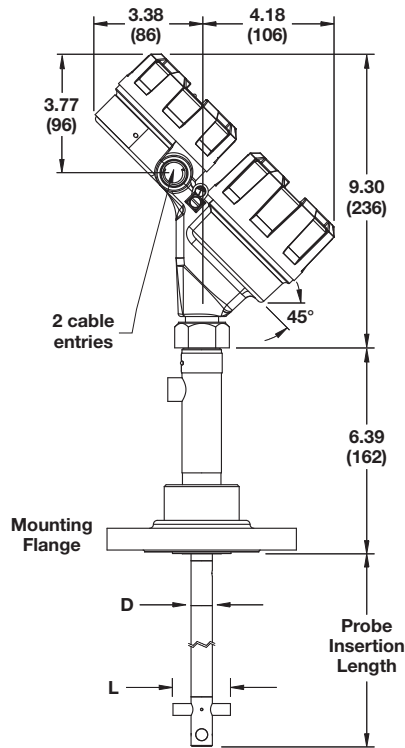

**Model 7yL**  
with flanged connection

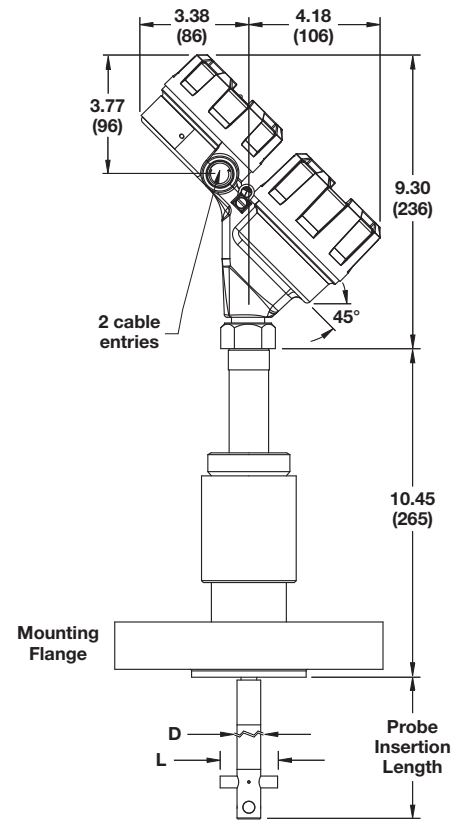

**Model 7yJ**  
with flanged connection

Cage Size	Probe Rod Diameter (D)	Spacer Length (L)
2"	0.5 to 0.75" (13 to 19 mm)	1.82" (46 mm)
3"	0.75 to 1.13" (19 to 29 mm)	2.64" (67 mm)
4"	1.05 to 1.50" (27 to 38 mm)	3.60" (91 mm)

# SINGLE ROD RIGID PROBE DIMENSIONS

INCHES (mm)

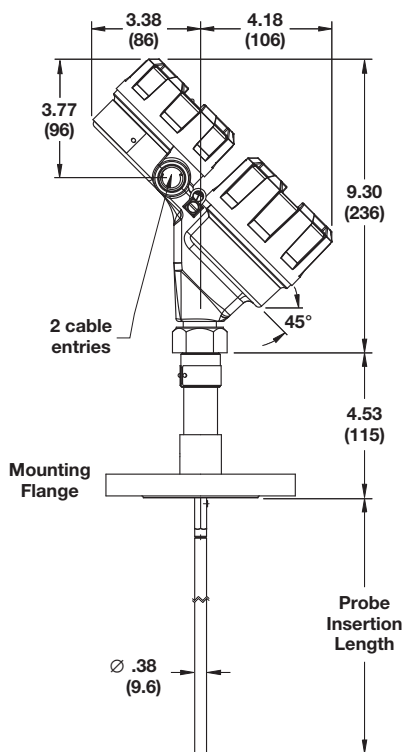

**Model 7yF**  
with flanged connection

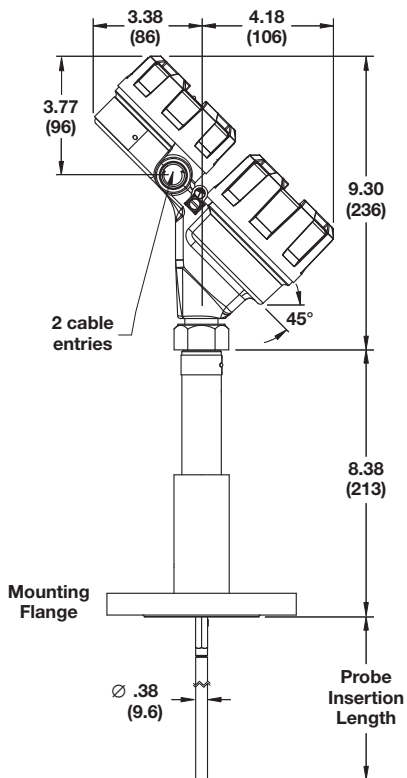

**Model 7yM**  
with flanged connection

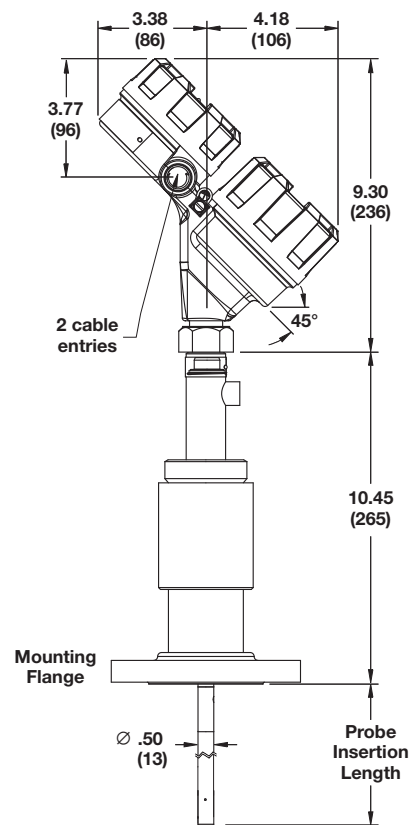

**Model 7yN**  
with flanged connection



# SINGLE FLEXIBLE PROBE DIMENSIONS

INCHES (mm)

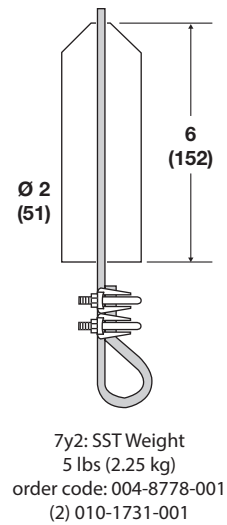
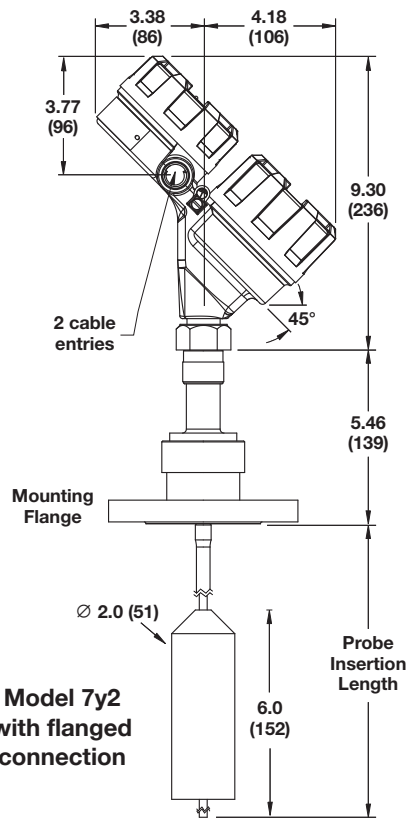
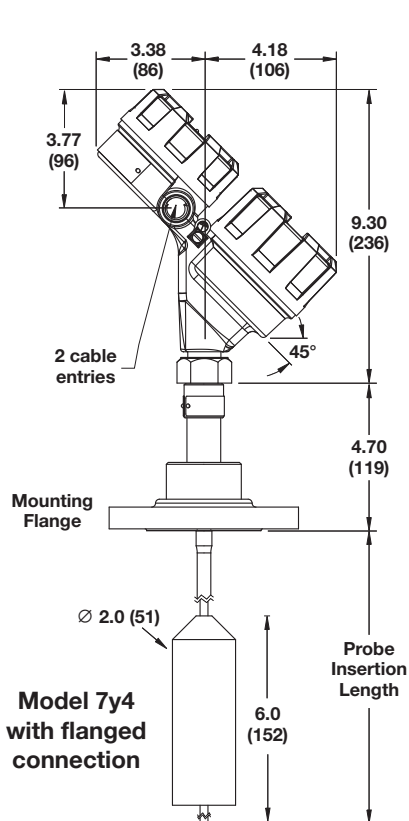
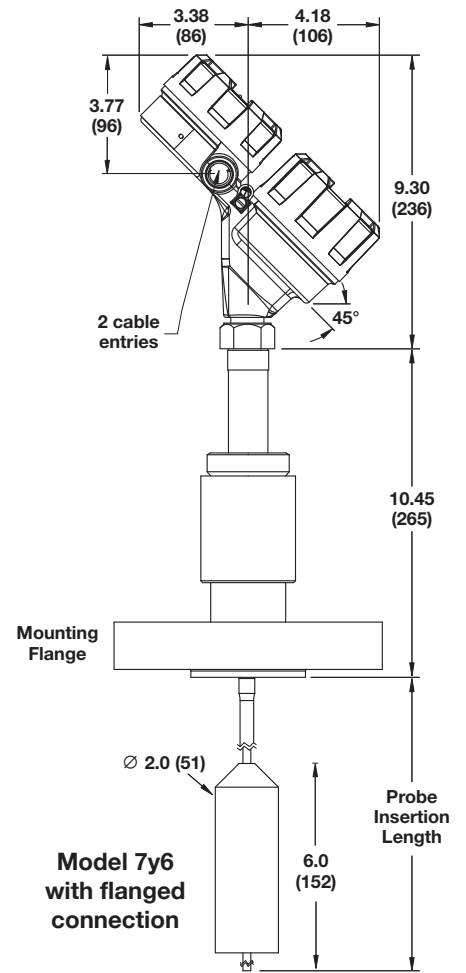
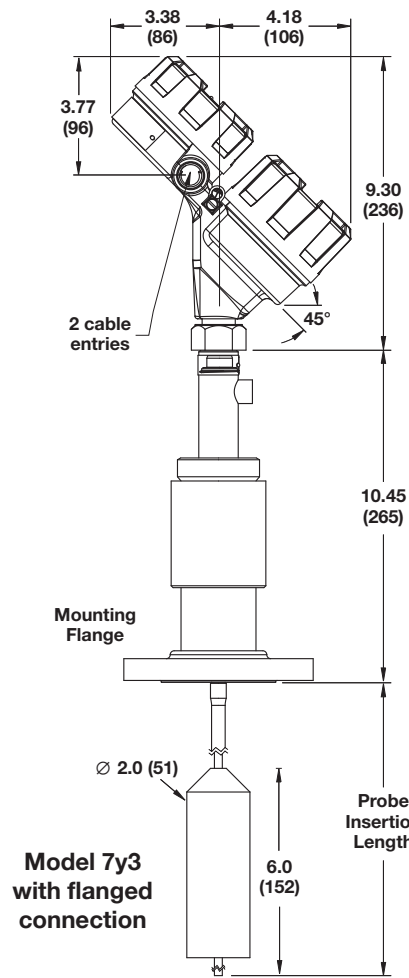
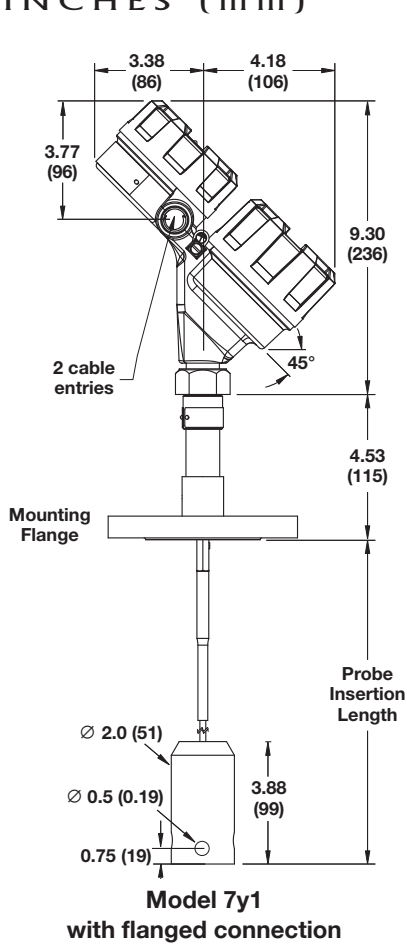

# “IN TANK” STANDARD SINGLE ROD PROBE MOUNTING CONSIDERATIONS

For Rigid Models 7yF, M, N and Flexible Models 7y1, 2, 4 and 6

## 1. Turbulence

The bottom of rigid probes should be stabilized if turbulence will cause a deflection of more than 3" (75 mm) at the end of a 10' (3 m) length. The probe should not make contact with metal.

## 2. Nozzle

Single rod performance in nozzles can be improved by ensuring the following:

- Nozzle must be 2" (50 mm) or larger diameter.
- Nozzle should be as short as possible.
- Nozzle inside diameter (A) should be  $\geq$  to nozzle height (B).
  - If this is not the case, adjustments to BLOCKING DISTANCE and/or SENSITIVITY parameters may be required.

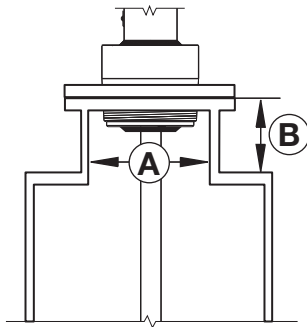

**Correct Installation**

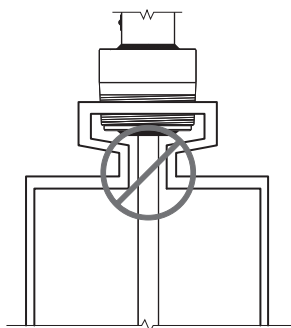

**Pipe reducers should not be used**

## 3. Metallic (conductive) obstructions in tank.

Although it depends on the transmitter configuration, objects in the proximity of the probe can cause erroneous readings. Please refer to the table below for guidelines, but please contact the factory with any questions as the distances shown can be reduced with the use of PACTware™.

Distance to probe	Acceptable objects
< 6" (150 mm)	Continuous, smooth, parallel, conductive surface (e.g. metal tank wall); probe should not touch tank wall
> 6" (150 mm)	< 1"/DN25 diameter pipe and beams, ladder rungs
> 12" (300 mm)	< 3"/DN80 diameter pipe and beams, concrete walls
> 18" (450 mm)	All remaining objects

**Note:** A metal stillwell/cage of max. 6"/DN150 size or a metal tank wall parallel to the probe within 6" (150 mm) will allow the unit to operate accurately in media with dielectrics down to  $\epsilon_r$  1.4.

## 4. Non-metallic vessels

A metal flange is highly recommended for optimum performance in plastic vessels.

NOTE: Single rod probes must be used in metallic vessels or stillwell to maintain CE noise immunity.

### Shutdown /Overfill protection

Special consideration is necessary in any shutdown/overfill protection application where single rod GWR probes are used. To ensure proper measurement, use Overfill Capable single rod probes, such as the Model 7yG, L, or J Caged probes in the appropriate cage/chamber/stillwell.

### Mounting Considerations for Single Flexible probes measuring Bulk Solids

The Model 7y2 Bulk Solid probe is designed for a 3000 lb. (1360 kg) pull-down force for use in applications such as sand, plastic pellets, and grains.

- To reduce excessive stresses on the top of the vessel, do not secure the metal probe weight to the bottom of the vessel.
- Mount the probe at least 12 inches from the wall. The ideal location is  $\frac{1}{4}$  to  $\frac{1}{2}$  the diameter to average the angle of repose.

# TWIN FLEXIBLE PROBE DIMENSIONS

INCHES (mm)

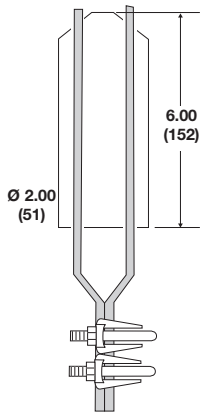

7y5: SST Weight  
5 lbs (2.25 kg)  
order code: 004-8778-002  
+ 2 x 010-1731-001

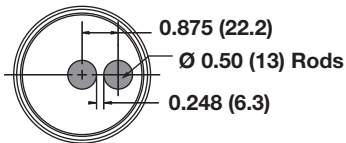

**Twin Flexible GWR Probe  
end view**

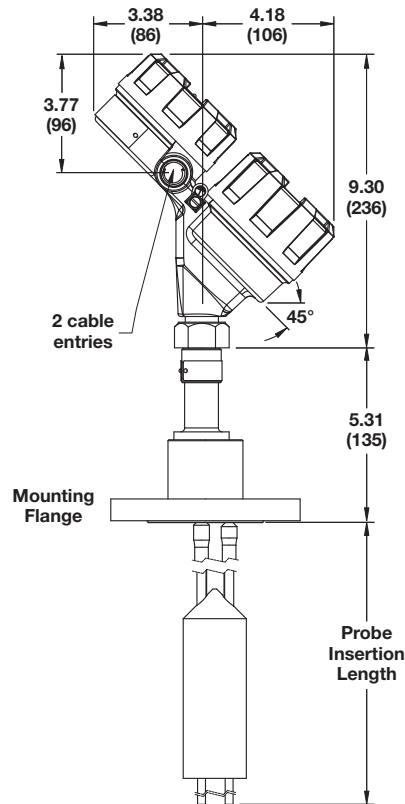

**Model 7y5  
with flanged connection**

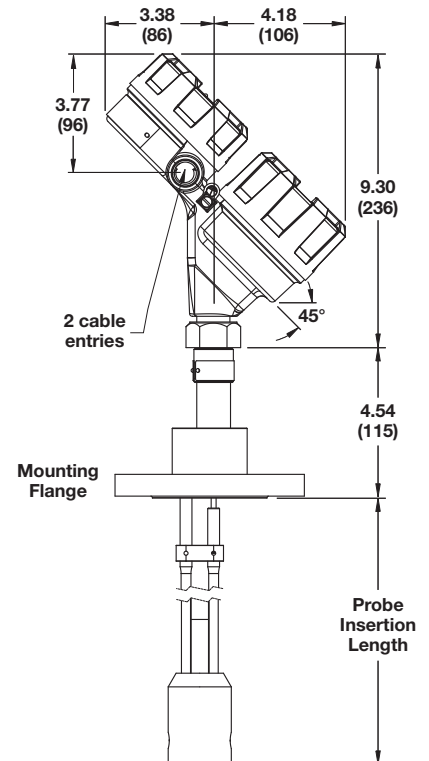

**Model 7y7  
with flanged connection**

## “IN TANK” TWIN FLEXIBLE PROBE MOUNTING CONSIDERATIONS

### For Models 7y7

#### 1. Turbulence

The bottom of Twin Flexible probes can be secured to the bottom of the vessel by using the TFE weight at the bottom of the probe. The TFE weight has a ½" (13 mm) hole that can be utilize to “u-bolt” the probe to the bottom of the vessel.

The probe should not make contact with metal.

#### 2. Nozzle

Twin Flexible probe performance in nozzles can be improved by ensuring the following:

- Nozzle should be 3" (DN80) diameter or larger.
- Nozzle should be as short as possible.

#### 3. Metallic (conductive) obstructions in tank.

Mount the Twin Flexible probe more than 1" (25 mm) from any metallic object/vessel wall.

Mounting Considerations for Twin Flexible Model 7y5 probes measuring Bulk Solids:

The Model 7y5 Bulk Solid probe is designed for a 3000 lb. (1360 kg) pull-down force for use in applications such as sand, plastic pellets, and grains.

- To reduce excessive stresses on the top of the vessel, do not secure the metal probe weight to the bottom of the vessel.
- Mount the probe at least 12 inches from the wall. The ideal location is ¼ to ½ the diameter to average the angle of repose.

The Orion Instruments® Aurora® is the patented combination of the ECLIPSE Guided Wave Radar transmitter and a Magnetic Level Indicator (MLI). The integration of these two independent technologies provides excellent redundancy. A custom float positioned within the AURORA chamber travels up and down following level changes. The float contains an internal group of magnets that are “coupled” with magnets in the flags of the visual indicator mounted on the outside of the chamber. As the float moves, the flags rotate to expose the color of their opposite side. The position where the flag’s color changes corresponds to a point on the measuring scale indicating true level. In addition to this external visual indicator operated by the AURORA internal float, the ECLIPSE Model 706 transmitter reflects electromagnetic radar pulses directly off the liquid surface providing a real-time continuous level output.

Refer to the Orion Instruments® ORI-138 brochure for details and additional options on AURORA chambers.

Regardless of whether a standard chamber or AURORA chamber is being used it is important to remember:

- Ensure that the Model 706 probe extends at least 4" (100 mm) past the lower process connection of the chamber
- Utilize Overfill-capable probes for optimal GWR performance.

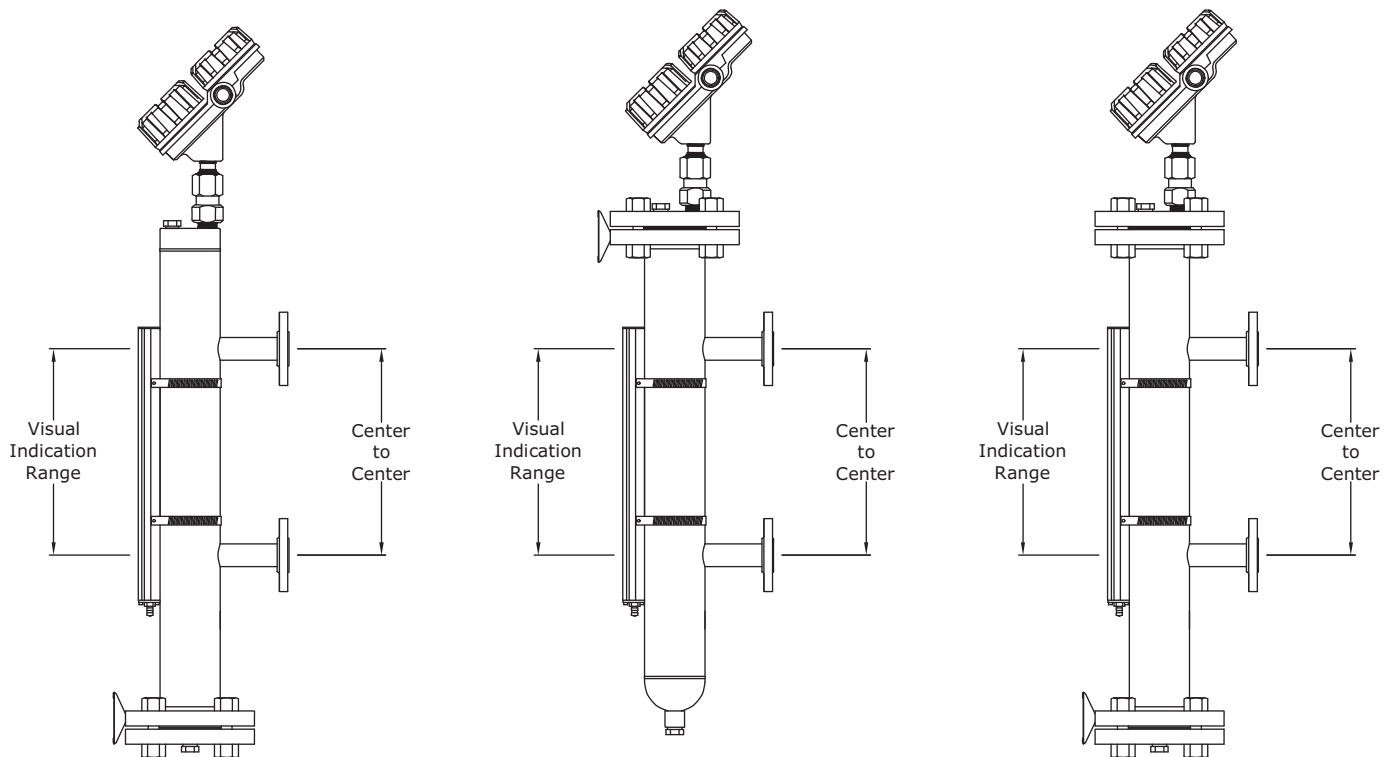

# QUALITY

---



The quality assurance system in place at MAGNETROL guarantees the highest level of quality throughout the company. MAGNETROL is committed to providing full customer satisfaction both in quality products and quality service.

The MAGNETROL quality assurance system is registered to ISO 9001 affirming its commitment to known international quality standards providing the strongest assurance of product/service quality available.

# ESP

---

## Expedite Ship Plan

Several Models of ECLIPSE Guided Wave Radar Transmitters are available for quick shipment, usually within one week after factory receipt of a complete purchase order, through the Expedite Ship Plan (ESP). Models covered by ESP service are color coded in the selection data charts.

To take advantage of ESP, simply match the color coded model number codes (standard dimensions apply).

ESP service may not apply to orders of ten units or more. Contact your local representative for lead times on larger volume orders, as well as other products and options.

# WARRANTY

---



All MAGNETROL electronic level and flow-controls are warranted free of defects in materials or workmanship for eighteen months from the date of original factory shipment.

If returned within the warranty period; and, upon factory inspection of the control, the cause of the claim is determined to be covered under the warranty; then, MAGNETROL will repair or replace the

control at no cost to the purchaser (or owner) other than transportation.

MAGNETROL shall not be liable for misapplication, labor claims, direct or consequential damage or expense arising from the installation or use of equipment. There are no other warranties expressed or implied, except special written warranties covering some MAGNETROL products.

For additional information, see Instruction Manual 57-606.

ECLIPSE Guided Wave Radar transmitters may be protected by one or more of the following U.S. Patent Nos. US 6,062,095; US 6,247,362; US 6,588,272; US 6,626,038; US 6,640,629; US 6,642,807; US 6,690,320; US 6,750,808; US 6,801,157;

US 6,867,729; US 6,879,282; 6,906,662. May depend on model. Other patents pending.



705 Enterprise Street • Aurora, Illinois 60504-8149 • 630.969.4000  
info@magnetrol.com • magnetrol.com

Copyright © 2018 Magnetrol International, Incorporated.

Performance specifications are effective with date of issue and are subject to change without notice.

Magnetrol & Magnetrol logotype, Orion Instruments & Orion Instruments logotype, ECLIPSE and MODULEVEL are registered trademarks of Magnetrol International, Incorporated.

CSA logotype is a registered trademark of Canadian Standards Association.  
Eckardt is a registered trademark of Invensys Process Systems.  
Fisher is a registered trademark of Emerson Process Management.  
FOUNDATION fieldbus logo is a registered trademark of the Fieldbus Foundation.  
HART is a registered trademark of the HART Communication Foundation.  
Hastelloy is a registered trademark of Haynes International, Inc.

Masonellan is a registered trademark of Dresser Industries, Inc.  
Monel is a registered trademark of International Nickel Co.  
PACTware is trademark of PACTware Consortium.  
Teflon is a registered trademark of DuPont.  
Tokyo Keiso is a registered trademark of Tokyo Keiso Co., Ltd.  
Viton and Kalrez are registered trademarks of DuPont Performance Elastomers.

**BULLETIN: 57-106.14**  
**EFFECTIVE: December 2018**  
**SUPERSEDES: March 2018**