

OPTO-MATIC® CLOSED SYSTEM OILERS

The Opto-Matic Closed System Oiler is designed for all types of equipment where a constant level in an oil sump must be maintained. The closed system design prevents contamination and spillage. The adjustable collar allows the oil level to be externally adjusted to the desired level. A 1/8 NPT port is provided for a vent line back to the housing to allow pressure balancing between the oiler and the housing.

FEATURES

- One piece glass reservoir ensures proper constant level function. Compared to competitive models, there is no possibility of air leakage that would cause overfilling of the housing.
- Adjustable level setting allows use in many applications
- Bottom of adjusting collar indicates actual oil level setting for easy set-up and maintenance
- Side and bottom connections for simplified installation
- 2" sight gauge for easy viewing of oil level



SELECTION CHART

Model No.	Capacity	Dimensions (in.)			
		A	B Min.	B Max.	NPT
30203	4 oz.	2-11/16	7-1/6	7-13/16	1/4
30205	8 oz.	3-3/16	8	8-3/4	1/4
30210	16 oz.	4-1/8	8-7/8	9-5/8	1/4

SPECIFICATIONS

Max. Operating Temp.	250°F Continuous
Reservoir	One-Piece Glass Bottle
Upper Casting	Zinc
Lower Body	Zinc
Adjusting Collar	Zinc
O-Ring	Vilton®

WIRE GUARDS

Wire guards are ordered separately and are customer installed.

Model No.	Description
30013	4 oz. Guard
30016	8 oz. Guard
30020	16 oz. Guard

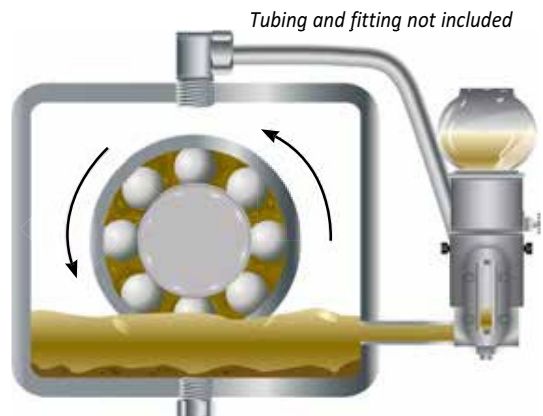

Opto-Matic closed system oiler with pressure balancing line

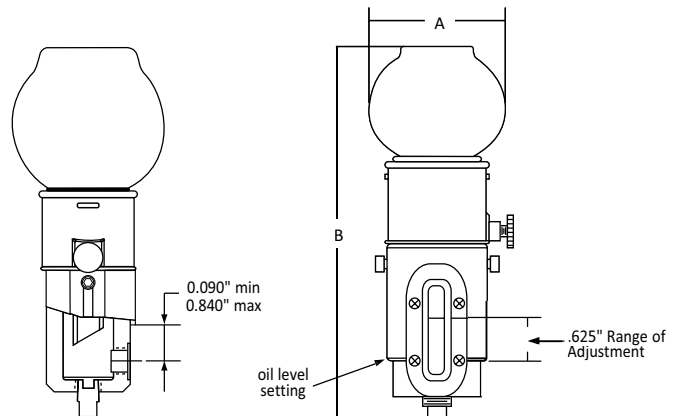

See Spectrum Opto-Matic Collars on page H10 for color coding options.