

Kamstrup 382 Generation M

DATA SHEET

- **3-phase residential meter**
 - **Prepared for Smart Home applications**
 - **Optimised for Smart Metering systems**
 - **Secured against tampering**
 - **Resistant to errors in the supply network**
 - **Ultra-low power consumption**
- **Type approved according to:**
 - Active energy
EN 50470-1 (MID)
EN 50470-3 (MID)
 - Active energy and reactive energy
IEC 62052-11
IEC 62053-21
IEC 62053-23



Application

Kamstrup 382M is a direct connected electricity meter for registration of electric energy. The meter is full electronic without movable parts. Thus, energy registration is not affected by shock or impact during transport and mounting. Furthermore, measurements are correct, no matter the physical mounting direction.

The shunt measuring principle secures good linearity and a considerable dynamic range. At the same time, the shunt measuring principle is immune to magnetism and DC currents.

The easily readable display scrolls automatically between readings, or readings can be changed manually by the consumer activating a push button. The required display readings as well as their order are configurable.

In addition to being read from the display, data can be collected via the optical output or from the module area. The unique module area also permits external changing of tariffs, pulse inputs and outputs, and configuration as well as a wide range of communication media.

From the factory, the meter can be configured to measure both imported and exported energy. As it is constructed with three independent and galvanically separated measuring systems, the meter makes accurate measurements whether it measures 1, 2 or 3 phases. Measurements are saved in a permanent memory.

As default, Kamstrup 382M can generate load profiles in all four quadrants.

A load profile provides detailed information about consumed and produced energy. An additional logger with 16 channels contains data for analysis purposes.

As default, Kamstrup 382M is supplied with the functions Smart Disconnect and software controlled Prepayment.

The meter registers loss of neutral conductor and allows automatic disconnection to avoid damages to household appliances.

In order to minimise the manual configuration during installation, the meter is pre-configured from the factory. Furthermore, the meter can be reconfigured via a Smart Metering system.

Reading Office

Cutbush Park, Danehill, Lower Earley,
Reading, Berkshire. RG6 4UT. UK.
Tel: +44 (0)118 9311188
Email: info@able.co.uk

Aberdeen Office

Unit 6 Airside Business Park, Kirkhill Industrial Estate,
Dyce, Aberdeen. AB21 0GT. UK.
Tel: +44 (0)1224 725999
Email: ab@able.co.uk

Internet: www.able.co.uk
e-procurement: www.247able.com
Registered in England No: 01851002
VAT No: GB 417 2481 61



Kamstrup 382 – Generation M

DATA SHEET

Contents

Functions	3
Approvals	6
Technical data	7
Connections	8
Communication	9
CCC-module	9
Typical accuracy charts	10
Installation	11
Safety and installation guidelines	11
Dimensions	12
Accessories	12

Reading Office

Cutbush Park, Danehill, Lower Earley,
Reading, Berkshire. RG6 4UT. UK.
Tel: +44 (0)118 9311188
Email: info@able.co.uk

Aberdeen Office

Unit 6 Airside Business Park, Kirkhill Industrial Estate,
Dyce, Aberdeen. AB21 0GT. UK.
Tel: +44 (0)1224 725999
Email: ab@able.co.uk

Internet: www.able.co.uk
e-procurement: www.247able.com
Registered in England No: 01851002
VAT No: GB 417 2481 61



Kamstrup 382 – Generation M DATA SHEET

Functions

Display

Kamstrup 382M is provided with a Liquid Crystal Display (LCD). The registers that can be read from the display depend on the chosen configuration. It is also possible to remotely configure the display.

The display configuration is constructed as three independent display lists: One for automatic shift function, one for manual shift function and one for back-up-powered shift function. The display is constructed of segments as shown in the figure below.

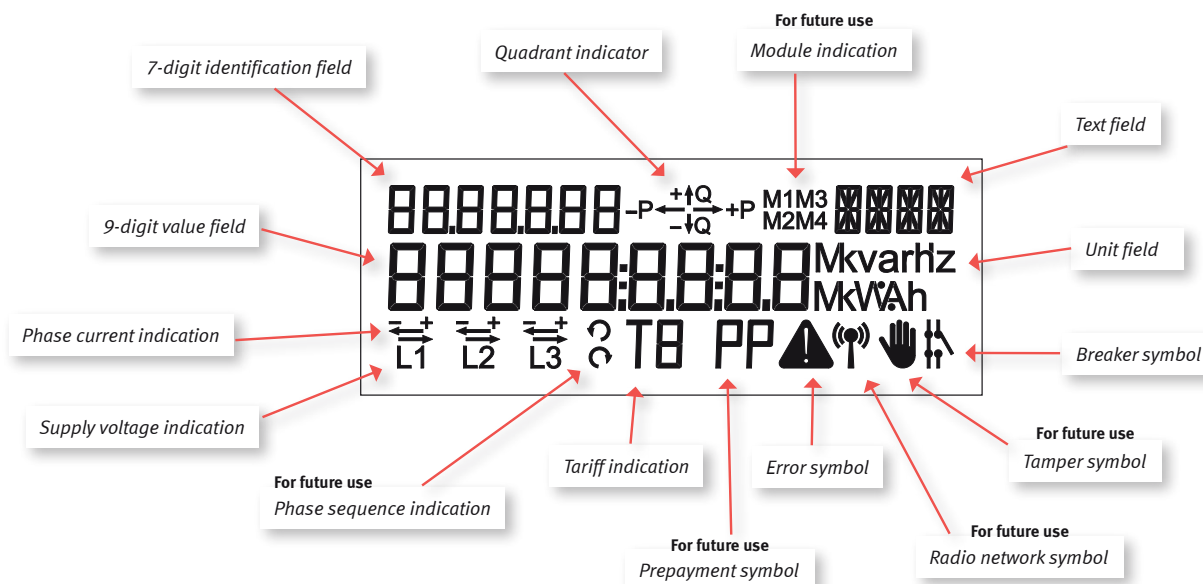

9-digit value field:	This field is used for displaying register values.
Unit field:	This field is used for displaying the units that are related to the value field.
7-digit identification field:	OBIS code identification of the value in the value field.
Quadrant indicator:	Indicates the current load type.
Text field:	Contains additional text in connection with the meter's function.
Error symbol:	Indicates critical internal errors, magnetic influence or opening of meter cover.
Breaker symbol:	Indicates the current position of the breaker. If the meter is without break, there is no indication.
Tariff indication:	Indicates the current tariff if tariffs have been selected.
Supply voltage indicator:	Indicates that the voltage is above the minimum threshold (160 V).
Phase current indication:	Indicates that the load is above the minimum threshold (2.3 W).

Kamstrup 382 – Generation M

DATA SHEET

Functions

Display

The automatic shift function (scroll) changes between the selected readings every 10 seconds. Historical data cannot be selected in the automatic shift function. Up to 16 readings can be selected.

The manual shift function changes through activation of the left push button. Up to 30 readings and the reading order can be selected. However, it is not possible to deselect the **legal** readings.

If the back-up-operated shift function is selected, it becomes possible to read the display, also when the meter is not power supplied. Up to 8 readings can be selected, and shifts between readings are made by activating the push button.

The meter automatically returns from manual shift function to automatic scroll function two minutes after the last activation of the push button.

Energy reading

Kamstrup 382M has one shunt per measuring system and resistance division for voltage measurement.

Energy consumption is calculated as an expression of the current compared to the phase voltage and time.

The energy registration per measuring system is communicated to the meter's legal processor via the meter's own internal bus system and is summed in the meter's main registers.

Permanent memory

Measured and calculated data are stored in the meter's permanent memory. Data are stored by every change of energy register values.

Furthermore, the below mentioned values are stored at the end of a debiting period:

Active energy A+
Active energy A-
Reactive energy R+
Reactive energy R-
Active energy A+ Tariff (T1-T4)
Reactive energy R+ Tariff (T1-T4)
Peak power P+max Tariff 1
Peak power P+max Tariff 1 Hour
Peak power P+max Tariff 1 Date
Peak power P+max Tariff 2
Peak power P+max Tariff 2 Hour
Peak power P+max Tariff 2 Date
Peak power P+max
Peak power P+max Date
Peak power P+max Hour
Accumulated peak power P+max acc
Date
Hour
Hour counter
Number of debiting periods
Power threshold counter
Pulse input

Reading Office

Cutbush Park, Danehill, Lower Earley,
Reading, Berkshire. RG6 4UT. UK.
Tel: +44 (0)118 9311188
Email: info@able.co.uk

Aberdeen Office

Unit 6 Airside Business Park, Kirkhill Industrial Estate,
Dyce, Aberdeen. AB21 0GT. UK.
Tel: +44 (0)1224 725999
Email: ab@able.co.uk

Internet: www.able.co.uk
e-procurement: www.247able.com
Registered in England No: 01851002
VAT No: GB 417 2481 61



Kamstrup 382 – Generation M

DATA SHEET

Functions

Plug-in modules

Kamstrup 382M can be mounted/retrofitted with plug-in modules without subsequent reverification.

The module communicates with the meter's microprocessor via an internal data bus. This provides innumerable functional possibilities such as extra pulse output, tariff, load control and data communication via e.g. GSM/GPRS, TCP/IP, Wireless M-Bus and Radio Mesh Network.

Optical reading

An optical sender/receiver is placed on the front of the meter. This optical connection can be used to read data or configure e.g. display set-up, meter number and other settings.

Changes via the optical connection can be made by using the software program METERTOOL.

It is not possible to change the meter's legal data.

SO pulse output

Emits pulses of active energy at 1000 pulses per kWh. The pulses are emitted synchronously with the LED. The maximum voltage, which may be connected to the SO output, is 27 V DC (at 1 kΩ), and the maximum current, which can be drawn through the output, is 27 mA. The pulse time is 30 msec.

Breaker

Kamstrup 382M is available with integrated disconnection function, which makes it possible to disconnect the electricity meter's supply outputs. The disconnection can be made locally by activating the meter's push button, automatically via the functions Smart Disconnect or Prepayment, or remotely via an automatic Smart Metering system.

Do **NOT** use the disconnection as a safety function.

The connection can be made via the same media as the disconnection. Furthermore, connection via push button can be configured to only be permitted after previous release command from a Smart Metering system.

The breaker is a bi-stable breaker that maintains its current position in the event of a power failure and after the subsequent re-establishment of power.

Load profile

Load profiles can be configured to 5, 15, 30 or 60 min. according to the integration period and for all four quadrants. The number of generated profiles corresponds to the selected energy type for the meter.

Logging depth in days:				
Minutes	5	15	30	60
A+	92	275	550	1100
A+ / A-	77	231	462	924
A+ / A- / R+ / R-	58	175	350	700

Analysis logger

Kamstrup 382M is provided with a configurable analysis logger. The logging depth will be 2.5 to 520 days depending on the configuration of the meter as well as the number of registers. The analysis logger can register data from up to 16 different registers at a time. Kamstrup 382M is available with default setting which can be reconfigured subsequently via METERTOOL or a Smart Metering system.

Tamper proof

Apart from the mechanical sealing, the meter also reveals tampering. In case of attempts of tampering (mechanical or magnetic), an alarm is activated which is time and date stamped and saved to the permanent memory. Alarms can be automatically transferred via the communication infrastructure and, in some case, indicated on the display. Magnetic influence does not affect the measuring accuracy.

Kamstrup 382 – Generation M

DATA SHEET

Approvals

Kamstrup 382M is type approved according to the Measuring Instruments Directive (MID) for active positive energy and according to the national requirements for other energy types, where required.

Approval	Norm
Type test according to:	
– Active energy	EN 50470-1 EN 50470-3
– Reactive energy and active energy	IEC 62052-11 IEC 62053-21 IEC 62053-23
 Various	 Norm
Terminal	DIN 43857
S0 pulse output	DIN 43864
OBIS/EDIS codes	IEC 62056-61

Kamstrup 382 – Generation M

DATA SHEET

Technical data

Measuring principle
 – Current
 – Voltage

Nominal voltage U_n

Single-phased current measurements by current shunt
 Single-phased voltage measurements by voltage divider

3x230 VAC -20 % - +15 % (for Aron meter only)
 1x230 VAC -20 % - +15 %
 2x230/400 VAC -20 % - +15 %
 3x230/400 VAC -20 % - +15 %

Current $I_{tr} - I_b (I_{max})$

Kamstrup 382M Without breaker	Kamstrup 382M With breaker
0.25-5(100)A 35 mm ²	0.25-5(85)A 35 mm ²

Accuracy class
 MID: Class A, Class B
 IEC: Class 2, Class 1

Nominal frequency f_n
 50/60 Hz $\pm 5\%$

Phase displacement
 Unlimited (however, not for Aron meters)

Operating temperature
 -40 °C - +70 °C

Storage temperature
 -40 °C - +85 °C

Protection class
 IP54

Protection class
 II

Relative humidity
 < 75 % year's average at 21 °C
 < 95 % less than 30 days/year, at 25 °C

Weight
 1.05 kg with breaker/ 0.90 kg without breaker

Application area
 Indoors or outdoors in suitable meter cabinet

Internal consumption

Kamstrup 382M	Without breaker	With breaker
Current circuit	0.01 VA	0.02 VA
Voltage circuit	0.4 VA	0.6 VA
	0.1 W	0.1 W

Materials
 Glass reinforced polycarbonate

Data storage
 EEPROM, > 10 years without voltage

Display
 LCD, 7 mm digit height (for value and unit fields)
 LCD, 5 mm digit height (identification readings)
 LCD, 3 mm digit height (voltage and tariff readings)

Kamstrup 382 – Generation M

DATA SHEET

Technical data

Meter constant	1000 imp/kWh
S0 pulse diode	1000 imp/kWh, kvarh Pulse time 30ms ± 10 %
S0 pulse output	1000 imp/kWh Pulse time 30ms ± 10 %
Short circuit level	4500 A
Real Time Clock (RTC)	
Accuracy	Typically 5 ppm at 23°C
Backup	Battery life > 10 years at normal operation Supercap life > 10 years at normal operation
Supercap operating time	4 days fully charged

Connections

Terminals	Elevator terminals		
Size	For use with connection:		
	Multi-cored	7-cored	Massive/terminal tube
35 mm ²	≥ 6 mm ²	≥ 6 mm ²	≥ 2.5 mm ²
Screws	Pz 2 or straight slot Tightening 2.5 - 3 Nm		
Voltage output	0.25 – 1.5 mm ² , 5 mm terminal forks		
Screws	TORX Tx 10 Torque 1 Nm		

Kamstrup 382 – Generation M

DATA SHEET

Communication

Kamstrup 382M can be supplied and retrofitted with communication modules. The modules function as inputs and outputs for the meter. Mounting of modules does not require subsequent verification of the meter.

Communication Modules

SO supply	Sends 24 V via a 2-wire and pulses by drawing the voltage to 0 V at each pulse. Can supply e.g. MULTICAL®.
Serial	Serial RS-485 or RS-232 communication or current loop with pulse inputs, tariff inputs or load control.
M-Bus	Reading via wired M-Bus system.
TCP/IP	Collection of consumption data via TCP/IP communication.
GSM/GPRS	Collection of consumption data via GSM/GPRS communication. Supports SMS reading.
Radio	Collection of consumption data via radio-based communication.

Integrated radio

Kamstrup 382M can be provided with built-in radio communication for Kamstrup Radio Mesh Network. Radio communication therefore requires no mounting/retrofitting of communication module. If the meter's module area is used for another type of communication, the built-in radio communication can be deactivated.

CCC-module

In Kamstrup 382M it is possible to mount a CCC- (Consumer Communication Channel) module. The module can be used for communication and data exchange with Smart Home products such as energy displays and external relays. The CCC-module is mounted without using tools or breaking the seal of the meter. The mounting may be done by e.g. the consumer himself.

Reading Office

Cutbush Park, Danehill, Lower Earley,
Reading, Berkshire. RG6 4UT. UK.
Tel: +44 (0)118 9311188
Email: info@able.co.uk

Aberdeen Office

Unit 6 Airside Business Park, Kirkhill Industrial Estate,
Dyce, Aberdeen. AB21 0GT. UK.
Tel: +44 (0)1224 725999
Email: ab@able.co.uk

Internet: www.able.co.uk
e-procurement: www.247able.com
Registered in England No: 01851002
VAT No: GB 417 2481 61



Kamstrup 382 – Generation M

DATA SHEET

Typical accuracy charts

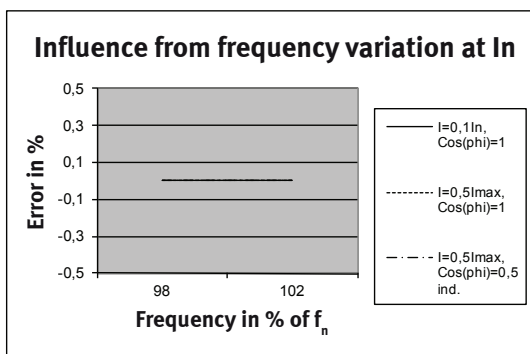
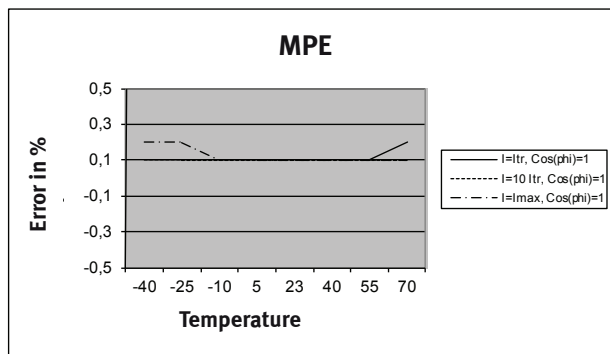
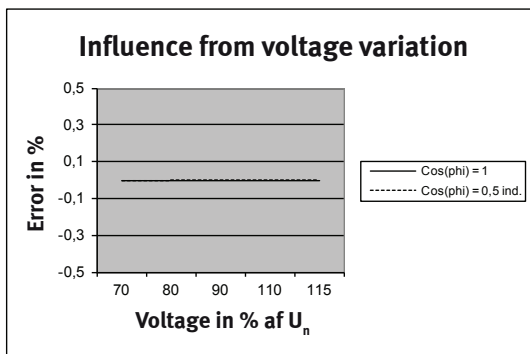
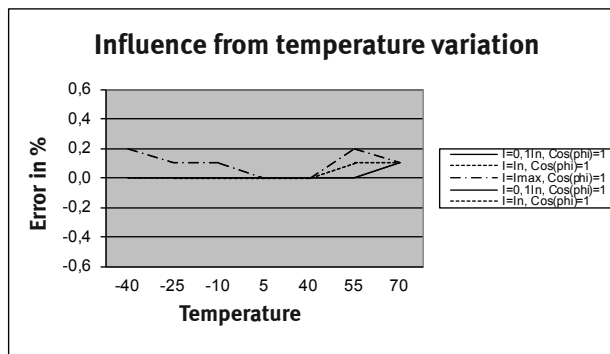
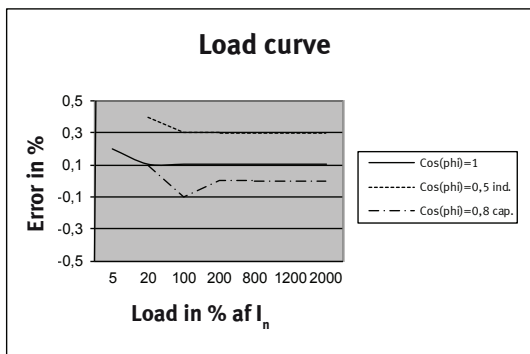

MPE (Maximum Permissible Error)

Error composed of:

- current load
- voltage variation
- frequency variation
- temperature variation

Kamstrup 382 – Generation M

DATA SHEET

Installation

Connection diagram

Connection diagram appears from the front of the meter.

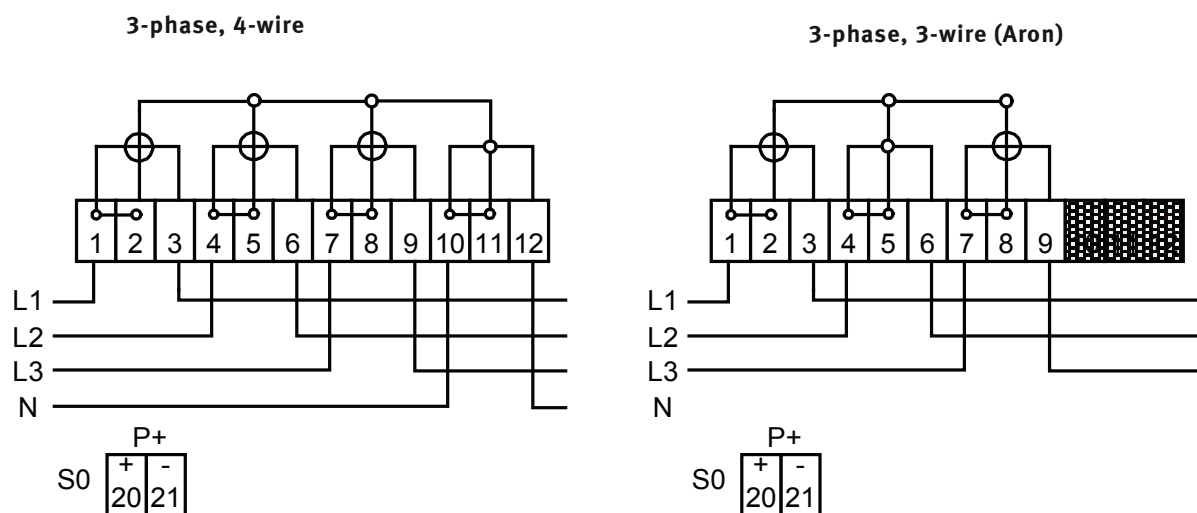

Safety and installation guidelines

- The meter shall only to be used for measuring electrical energy and shall operate within the specified values only.
 - The meter must be switched off when working on it. It can be highly dangerous to touch connected meter parts.
 - Current local standards, guidelines, regulations and instructions must be observed. Only authorized personnel are permitted to install electricity meters.
 - Meters for direct connection must be protected against short circuit by a backup fuse in accordance with the maximum current stated on the meter.
 - The relevant backup fuse must therefore be removed and kept in a place where it cannot be inserted by unauthorized personnel.
 - The meter constant LED flashes proportionally to the consumed active energy.
 - Only authorized personnel must break the utility sealing.
- Warning!** The breaker function in the meter must *not* be used as safety function. When the meter's breaker function is used, the meter is still carrying a voltage.

Kamstrup 382 – Generation M

DATA SHEET

Dimensions

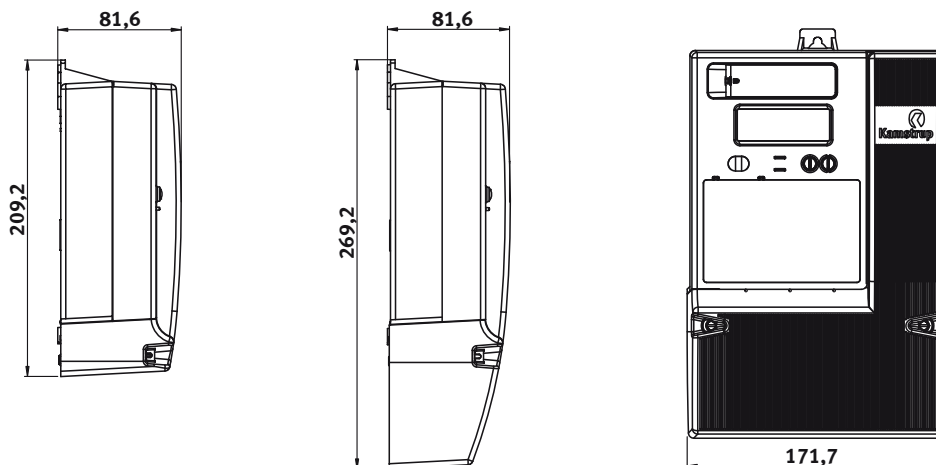

Accessories

Modules

SO supply module	68 50 001
Data/pulse module, relay output	68 50 075
Tariff module, 4 tariffs, 230 VAC, current loop	68 50 018
IP101i, TCP/IP module	68 50 040
GSM6i, GSM6i/RF, GSM7i, GSM8i	68 50 053
5A load control module	68 50 058
M-Bus module	68 50 068
5A load control module	68 50 069
RS485	68 50 072

Software

Configuration SW, METERTOOL OMNIPower	68 99 580
---------------------------------------	-----------

Various

Standard cover for 382M	59 60 315
Long terminal cover 60 mm	59 60 316
Optical reading head with USB plug	66 99 099
Optical reading head with 9-pole D-sub connector	66 99 102
METERTOOL kit	68 30 017
Pins, 50 pcs.	68 50 102
Cable sockets, 50 pcs.	68 50 103