

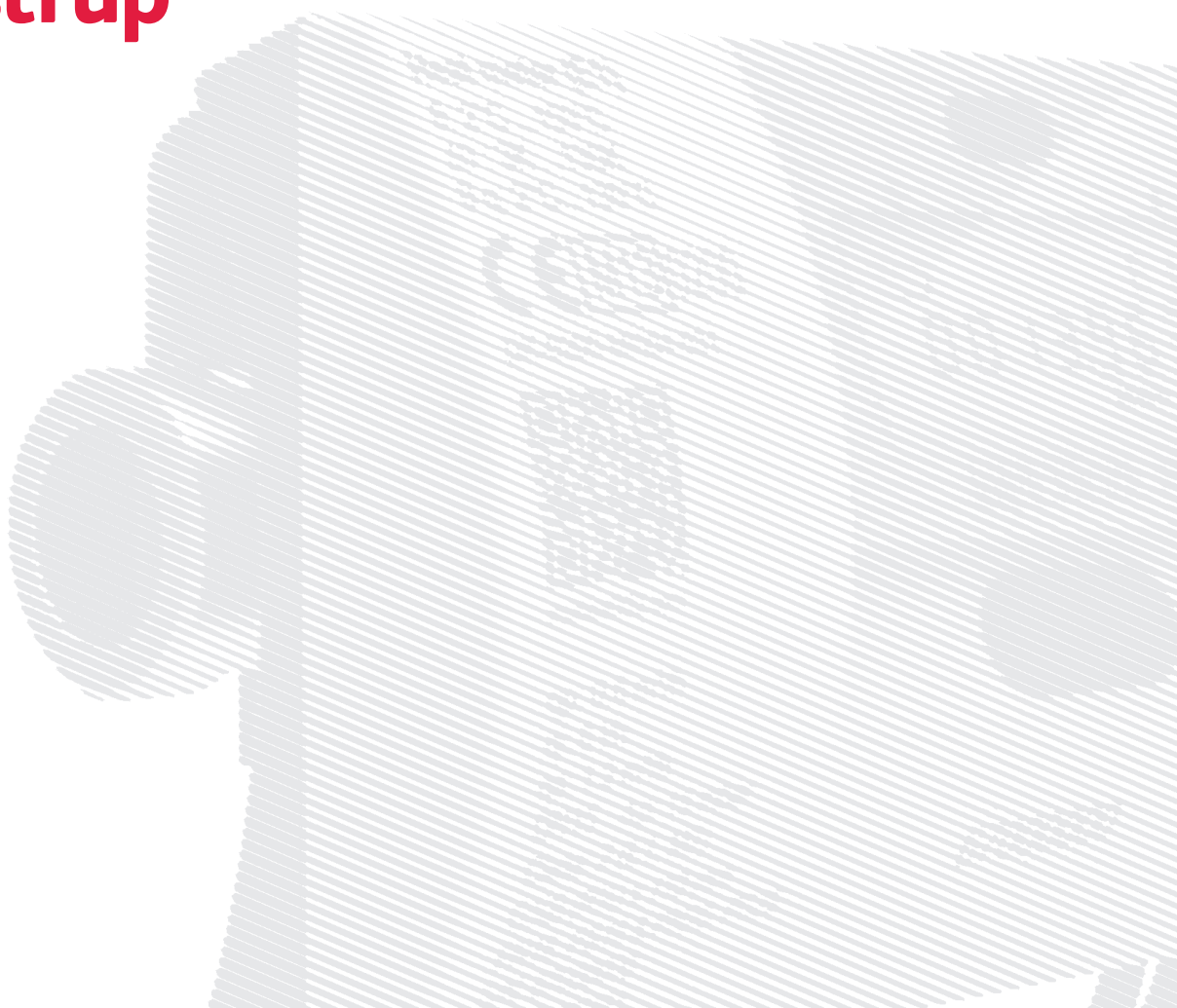

Installation & Maintenance Instructions

MULTICAL[®] 302

kamstrup



MID designations

Permissible operating conditions / measuring ranges

Calculator	θ : 2 °C...150 °C	$\Delta\theta$: 3K...130K
Temperature sensor set	θ : 2 °C...150 °C	$\Delta\theta$: 3K...130K
Flow sensor	θ : 2 °C...130 °C	

Also available as cooling meter with temperature range 2 °C...150 °C (alternatively 2 °C...50 °C) or as combined heat/cooling meter with temperature range 2 °C...150 °C, however with MID approval on the heat register only.

Mechanical environment

M1 and M2 (fixed installation with minimum vibration and fixed installation with considerable or high vibration level, respectively).

Electromechanical environment

E1 (housing/light industry). The meter's signal cables must be drawn with a minimum distance of 25 cm to other installations.

Climatic environment

Installation must take place in environments with non-condensing humidity and in closed locations (indoors). The ambient temperature must be within 5 °C...55 °C. The flow sensor, however, may be installed in condensing environments.

Maintenance and repair

The flow sensor and the temperature sensors must not be separated from the calculator. Repairs require subsequent reverification in an accredited laboratory.

Contents

1	General information	4
2	Temperature sensors	4
2.1	Mounting of temperature sensors	4
2.2	Coupling for direct sensor	5
3	Information codes "INFO"	6
4	Mounting of flow sensor	7
4.1	Wall mounting of MULTICAL® 302	9
4.2	Flow direction	10
4.3	Installation position	10
4.4	Humidity and condensation	10
5	Mounting of calculator	10
5.1	Compact mounting	10
5.2	Wall mounting	12
6	Battery supply	12
7	Testing the function	12
8	Communication	13
8.1	Wired M-Bus communication	13
8.2	Wireless M-Bus communication (radio)	13
9	Setup mode	14
9.1	Changing the installation position	15
9.2	Changing the energy unit	16

1 General information

 Please read this guide carefully before installing the energy meter.

In case of incorrect mounting, Kamstrup's guarantee obligations no longer apply.

Note that the following installation conditions must be obeyed:

- Pressure stage: PN16/PN25, see marking. The flow sensor marking does not apply to enclosed accessories.
- Pressure stage sensor set type Ø 5.2: PN16 and PN25

At medium temperatures above 90 °C, and below 15 °C, and the calculator should be wall-mounted.

2 Temperature sensors

The temperature sensors used to measure inlet and outlet temperatures, respectively, are a matched sensor set that must never be separated.

Temperature sensors are mounted in MULTICAL® 302 from the factory. According to EN 1434, the cable length must not be changed.

The temperature sensor which is mounted in the flow sensor from the factory has no marking on the sensor cable. The other sensor, which is marked with a green plastic ring, must be mounted in the "opposite" pipe compared to the flow sensor.

2.1 Mounting of temperature sensors

MULTICAL® 302 comes with a Ø 5.2 mm Pt500 sensor pair (matched sensors) with 1.5 m silicone cable. This sensor type can be used as direct sensor using a coupling and an O-ring and as pocket sensor to be mounted in a sensor pocket.

One temperature sensor is mounted in the flow sensor from the factory. The other sensor ought to be mounted as direct sensor. Alternatively, both sensors must be mounted in sensor pockets as symmetrical sensor installation gives the best measuring result. If one of the sensors is not to be mounted in the flow sensor, it must instead be mounted as close to the outlet of the flow meter as possible so that the distance between the flow sensor and the temperature sensor is max. 12 cm.

Asymmetrical sensor installation (one direct sensor and one pocket sensor) is only advisable where national regulations allow this, and never in systems with low differential temperature and/or low water flow.

Example:

If the display shows that the flow sensor is to be mounted in the inlet pipe, the sensor with the green plastic ring must be mounted in the outlet pipe.



2.2 Coupling for direct sensor



Slide the enclosed plastic coupling into place from the end of the sensor tube until you feel a click when the coupling has reached the first knurling.

The coupling must not be pushed further down than the first knurling.

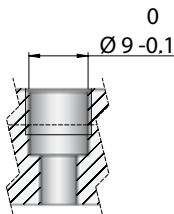
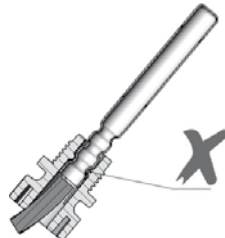
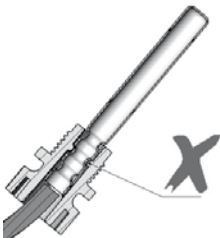

No matter where the direct sensor is installed, it is very important that you observe the tolerances stated in the drawing to the left. If not, the O-ring may not provide correct sealing.

3 Information codes "INFO"

MULTICAL® 302 constantly monitors a number of important functions. If there is a serious error in the measuring system or installation, a flashing "INFO" is displayed, and an info code can be read by activating the push-button until the measuring unit displays "INFO". The info code is only shown if an error has occurred, unless the meter is configured for "static info codes".

Info code	Description	Response time
0	No irregularities	-
1	Supply voltage has been interrupted	-
4	Temperature sensor T2 outside measuring range	< 32 secs.
8	Temperature sensor T1 outside measuring range	< 32 secs.
32	Temperature difference has wrong polarity	32 secs. and 0.05 m ³
128	Supply voltage too low	< 10 secs.
16	Flow sensor with weak signal or air	< 32 secs.
2	Flow sensor with wrong flow direction	< 32 secs.

If more than one info code appears at a time, the sum of info codes is displayed. If e.g. both temperature sensors are outside measuring range, info code 12 (info codes 4+8) is displayed.

Info codes 4 and 8 are set when the temperature falls below 0.00 °C or exceeds 155.00 °C. Info codes 4 and 8 are also set for short-circuited and disconnected sensors.

Note: If Info = 4 or 8, the meter's energy calculation and volume accumulation stop.

4 Mounting of flow sensor

Prior to installation of the flow sensor, the system should be flushed and protection plugs/plastic diaphragms removed from the flow sensor.

Correct flow sensor position (inlet or outlet) appears from the display of MULTICAL® 302. The flow direction is indicated by an arrow on the side of the flow sensor.

The flow sensor may be used in both PN16 and PN25 installations and is available marked either PN16 or PN25 or marked both PN16 and PN25, as required.

Enclosed couplings, if any, are only intended for PN16. Suitable PN25 couplings must be used in PN25 installations.

In connection with G $\frac{3}{4}$ x110 mm, it must be checked that 12 mm thread run-out is sufficient. See figure below.

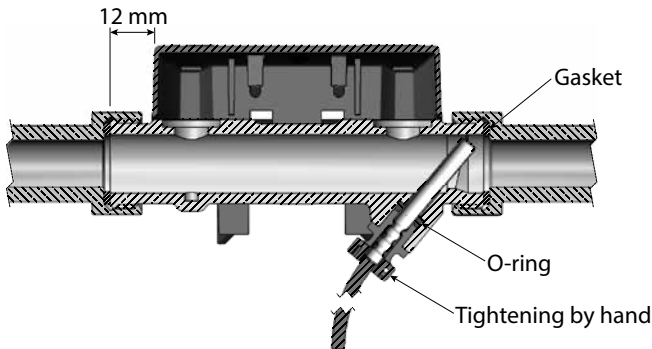

Straight inlet: MULTICAL® 302 requires neither straight inlet nor straight outlet to meet the Measuring Instruments Directive (MID) 2004/22/ EF and EN 1434:2007. A straight inlet section is only necessary in case of heavy flow disturbances before the meter. It is recommended to follow the guidelines of CEN CR 13582.

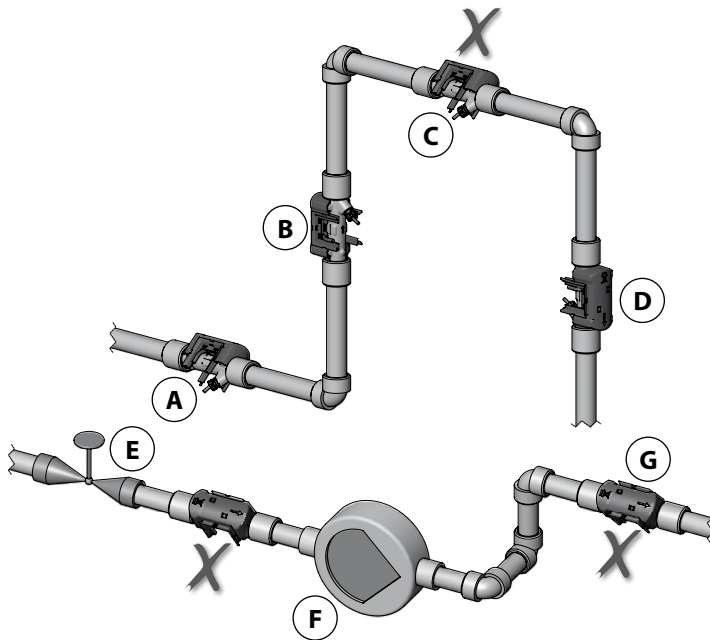

- A** Recommended flow sensor position
- B** Recommended flow sensor position
- C** Unacceptable position due to risk of air build-up
- D** Acceptable position in closed systems
- E** A flow sensor should not be placed immediately after a valve, except for block valves, which must be fully open when not used for blocking
- F** A flow sensor should not be placed close to the inlet side of a pump
- G** A flow sensor should not be placed close to a two-level double bend

In order to prevent cavitation, the operating pressure at MULTICAL® 302 must be min. 1 bar at q_p and min. 2 bar at q_s . This applies to temperatures up to approx. 80 °C.

MULTICAL® 302 must not be exposed to pressure lower than the ambient pressure (vacuum).

4.1 Wall mounting of MULTICAL® 302

MULTICAL® 302 can be mounted vertically, horizontally or at an angle.

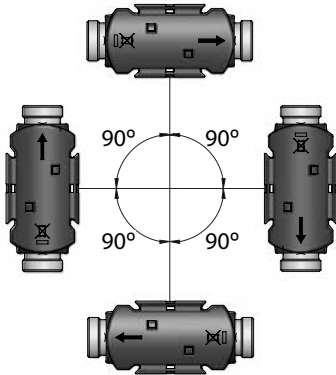

MULTICAL® 302 may be turned upwards to max 45° and downwards to max 90° compared to the pipe axis.

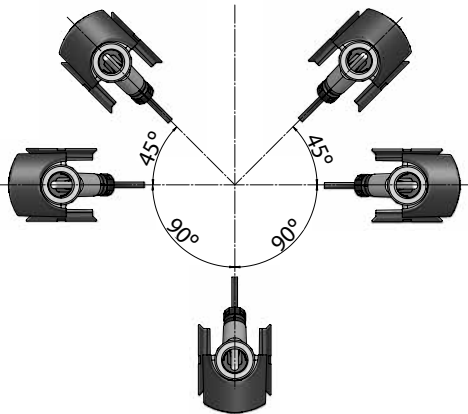

Important

The meter is most sensitive to air bubbles in the water when the plastic case points upwards. Therefore, this mounting position ought only to be used in installations with high operating pressure and automatic ventilation like e.g. direct connected district heating.

4.2 Flow direction

When the meter is installed in the application, it must be ensured that the flow direction is correct.

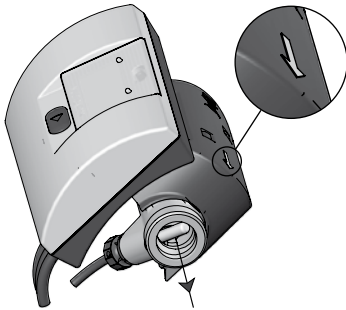

Flow direction out of the figure – the direction is indicated on the flow sensor.

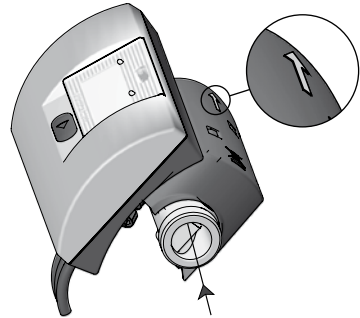

Flow direction into the figure – the direction is indicated on the flow sensor.

4.3 Installation position

In the upper left corner of the meter display, an icon indicates if the meter is positioned in the inlet or outlet pipe.



Icon for inlet meter



Icon for outlet meter

It is very important to ensure that the meter is correctly positioned as either inlet meter or outlet meter. The installation position of the meter can be changed in the Setup Mode (for further information, see paragraph 9.1, page 15).

4.4 Humidity and condensation

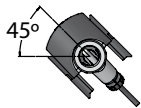

If MULTICAL® 302 is installed in moist environments, it must be turned 45° compared to the pipe axis, as shown in the drawing to the left.

5 Mounting of calculator

5.1 Compact mounting

The calculator is mounted directly on the flow sensor. The calculator is sealed from the factory, and therefore, further sealing is unnecessary, unless the seals on the back of the calculator have been broken.

In case of strong condensation (e.g. cooling applications), wall mounting of the calculator is recommended, see paragraph 5.2, page 12.

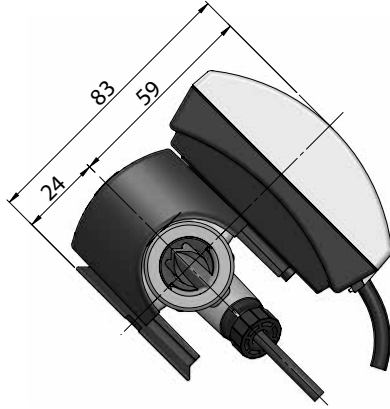

At compact mounting, it is possible to remove the cable retainer from the flow cable by first releasing the cable retainer (A), and then put the cable retainer through one of the two mounting eyes on the side of the flow sensor (B). Finally, the cable retainer is fixed around the flow cable so that the cable is tied together with the flow sensor (C).

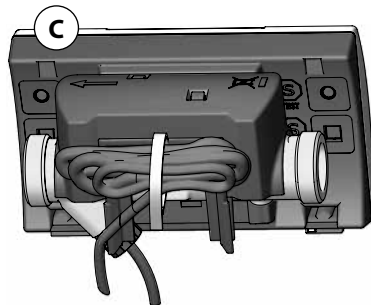
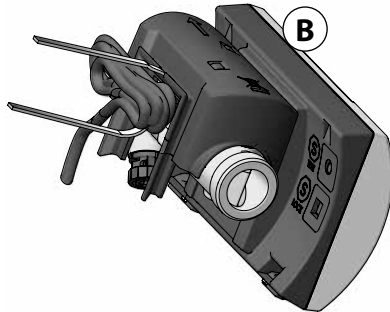

5.2 Wall mounting

The wall fitting makes it possible to mount MULTICAL® 302 directly on an even wall. Use the fitting as a template to mark and drill two 6 mm holes in the wall.

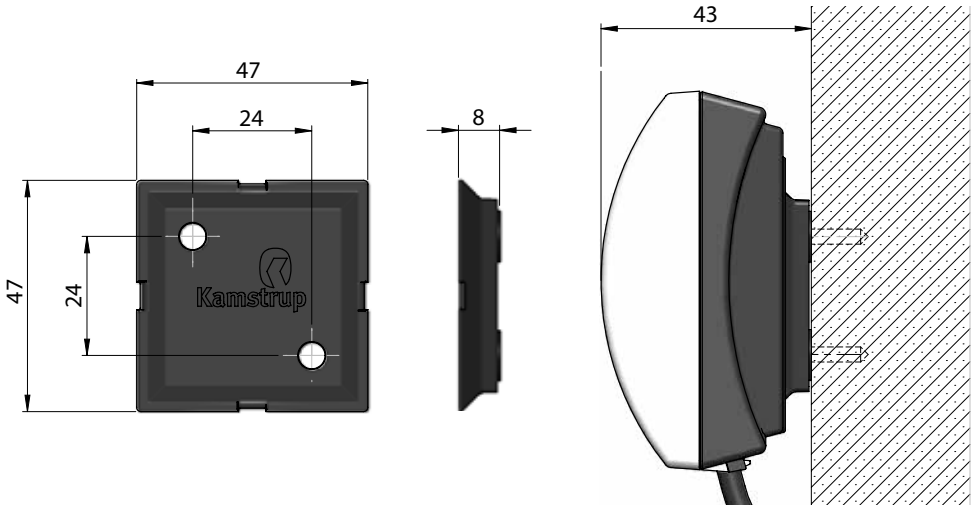

6 Battery supply

MULTICAL® 302 is battery-supplied with either 1 or 2 A-cell batteries. Optimal battery lifetime is obtained by keeping the battery temperature below 30 °C, e.g. by wall mounting.

The voltage of a lithium battery is almost constant throughout the lifetime of the battery (approx. 3.65 V). Therefore, it is not possible to determine the remaining capacity of the battery by measuring the voltage. However, INFO code 128 indicates that the battery voltage is too low.

The battery cannot and must not be charged and must not be short-circuited. Used batteries must be handed in for approved destruction, e.g. to Kamstrup A/S.

7 Testing the function

Carry out an operational check when the energy meter has been fully mounted. Open thermo-regulators and cocks to establish water flow through the heating system. Press the push-button of MULTICAL® 302, and check that the displayed values for temperatures and water flow are credible values.

8 Communication

MULTICAL® 302 can be delivered with or without remote communication. If the meter is delivered with remote communication, it can be either wired M-Bus or wireless M-Bus (radio communication).

8.1 Wired M-Bus communication

If the meter is supplied with built-in wired M-Bus, M-Bus protocol according to EN 13757-3:2013 is used.

The connection to the M-Bus master takes place via the fixed 2-wire cable of 1,5 m. The connection is independent of polarity, and the M-Bus interface is galvanically separated from the rest of the meter.

M-Bus comes with primary, secondary and enhanced secondary addressing. The M-Bus address is indicated at the placing of the order, but can subsequently be changed in the Setup mode (see paragraph 9, page 14).

8.2 Wireless M-Bus communication (radio)

If the meter has integrated wireless M-Bus, it is possible to select between Mode C1 or Mode T1 OMS. Mode C1 is used in connection with Kamstrup's reading systems and in general for drive-by meter reading. Mode T1 OMS is used in connection with OMS-based stationary networks.

The meter has an internal antenna.

Mode C1

Protocol according to EN 13757-4:2013. Transmission interval 16 secs. Individual 128-bit AES encryption.

Mode T1 OMS

Protocol according to EN13757-4:2013 and OMS Specification, Volume 2, Issue 3.0.1. Transmission interval of 900 secs. Individual 128-bit AES encryption.

9 Setup mode

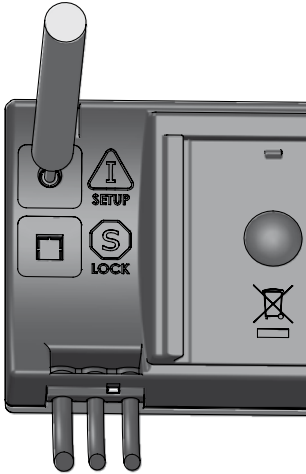

Setup

When delivered, the meter is in transport state, which means that the display loop "Setup" is available.



The Setup loop is selected by activating the button continuously for 9 secs. until "SETUP" is displayed.

The meter remains in Setup loop until the front button is pressed for 5 secs. However, a time-out secures that the meter reverts from Setup mode to normal mode after 4 minutes.

Transport state ends when the meter has registered its first volume accumulation, either 0.01 m³ (10 L) or 0.001 m³ (1 L) – determined by the selected resolution.

Note: The option Setup has been deselected in certain country codes.

The readings of Setup loop are listed below including index numbers:

Setup loop (Loop_3)		Index number in display
1.0	Customer number (No. 1)	3-01
2.0	Customer number (No. 2)	3-02
3.0	Date	3-03
4.0	Hour	3-04
5.0	Target date (MM.DD)	3-05
6.0	Flow sensor in: Inlet or Outlet (code A)	3-06
7.0	Measuring unit and resolution (code B)	3-07
8.0	M-Bus primary address (No. 31)	3-08
9.0	Average time of max P and Q	3-09
10.0	θ_{hc} (can only be changed with country code 6xx. Other country codes show 180 °C without the changing option)	3-10
11.0	Radio "ON" or "OFF"	3-11
12.0	End setup	3-12

After 4 minutes without activation of the button, the meter reverts to energy reading in the User loop.

9.1 Changing the installation position

The setup of the meter's installation position can be changed from inlet meter to outlet meter (and vice versa):

For this purpose, display 3-06 is used. Now, the following is to be carried out:



Inlet

If the meter is set to be placed in the inlet, the text "inlet" is displayed. In order to change the setting, press the button for two seconds. "Setup" is briefly displayed, and then "Inlet" flashes. Press the button once, and "Outlet" is displayed. If you want to save the setting, press the button for two seconds until "OK" appears in the display.



Outlet

If the meter is set to be placed in the outlet, the text "Outlet" is displayed. In order to change the setting, press the button for two seconds. "Setup" is briefly displayed, and then "Outlet" flashes. Press the button once, and "Inlet" is displayed. If you want to save the setting, press the button for two seconds until "OK" appears in the display.

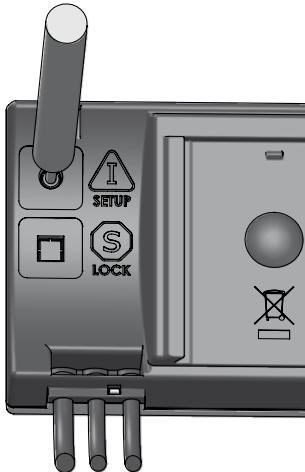

When the transport mode has been cancelled, you only have access to the Setup loop if the installation seal is broken and the contact points behind the seal are short-circuited.

9.2 Changing the energy unit

The energy unit can be changed. In order to do so, follow the example in paragraph 9.1, page 15, but instead of reading 3-06, reading 3-07 is to be used.

If you change the energy unit setting in Setup loop, you must be aware that the change can influence the most significant digits of the display. If for instance you change from GJ with 2 decimals to GJ with 3 decimals, the most significant digit disappears. The same applies if you change from kWh without decimals to kWh with 1 decimal. And conversely, the least significant digit disappears if e.g. you change from kWh with 1 decimal to kWh without decimals. See examples below:

Example 1

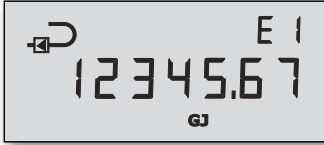

GJ with 2 decimals (B=2)

This is an example of how the energy reading E1 can appear – counted in GJ.

Example 2



GJ with 3 decimals (B=6)

Here the most significant digit has disappeared compared to example 1. In return you receive a higher resolution.

Example 3



kWh without decimals (B=3)

This is an example of how energy reading E1 can appear – counted in kWh.

Example 4

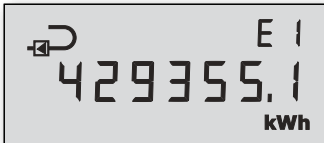

kWh with 1 decimal (B=7)

Here the most significant digit has disappeared compared to example 3. In return you receive a higher resolution.

Example 5



MWh with 3 decimals (B=4)

In principle, this is the same resolution as in example 3, but energy is now counted in MWh.

MULTICAL[®] 302

Display readings

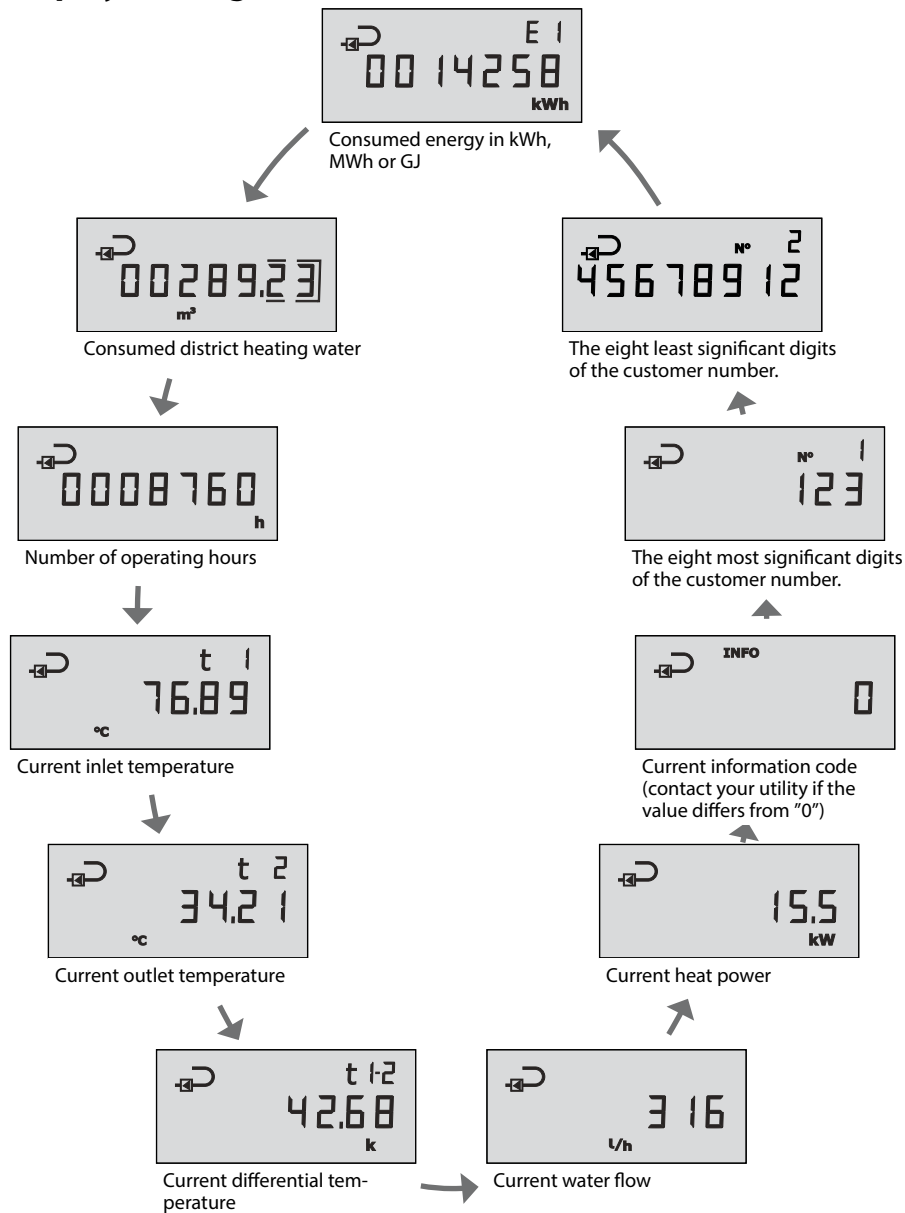



MULTICAL® 302

User instructions



Energy measurement

MULTICAL® 302 functions in the following way:

The flow sensor registers the amount of district heating water flowing through the heating system in m³ (cubic metres).

The temperature sensors placed in inlet and outlet pipes register the cooling, i.e. the difference between input and output temperatures.

MULTICAL® 302 calculates consumed energy based on volume of district heating water and cooling.

Readings

The display is activated by pressing the front button. Then, press the button to change to another display.

Four minutes after the latest activation of the front key, the meter automatically switches to consumed energy.