

**Advanced
Differential
Pressure
Flowmeter
Technology**

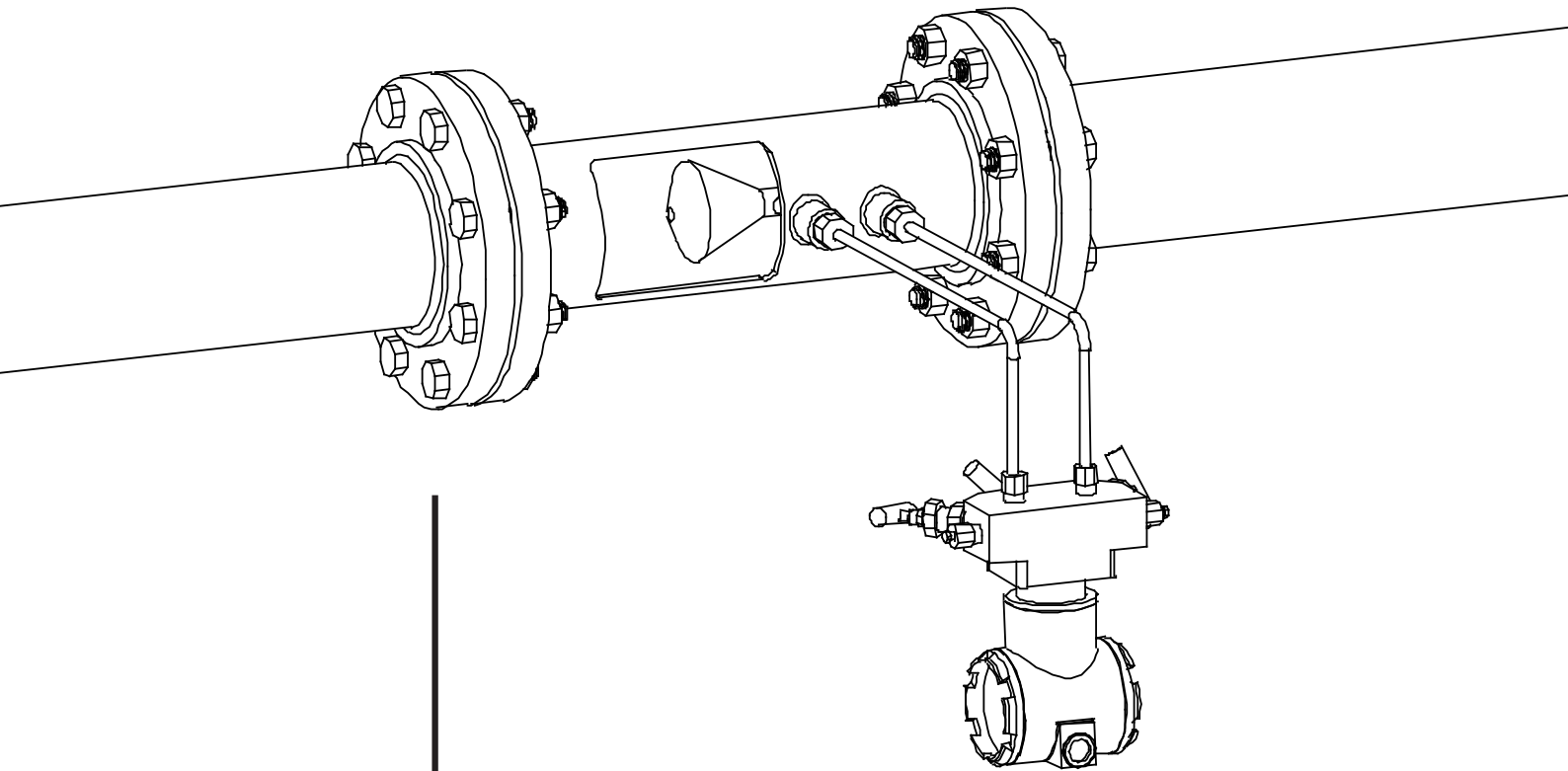

V-CONE FLOW METER TECHNICAL BRIEF

Reading Office

Cutbush Park, Danehill, Lower Earley,
Reading, Berkshire. RG6 4UT. UK.
Tel: +44 (0)118 9311188
Email: info@able.co.uk

Aberdeen Office

Unit 6 Airside Business Park, Kirkhill Industrial Estate,
Dyce, Aberdeen. AB21 0GT. UK.
Tel: +44 (0)1224 725999
Email: ab@able.co.uk

Internet: www.able.co.uk
e-procurement: www.247able.com
Registered in England No: 01851002
VAT No: GB 417 2481 61





Reading Office
Cutbush Park, Danehill, Lower Earley,
Reading, Berkshire. RG6 4UT. UK.
Tel: +44 (0)118 9311188
Email: info@able.co.uk

Aberdeen Office
Unit 6 Airside Business Park, Kirkhill Industrial Estate,
Dyce, Aberdeen. AB21 0GT. UK.
Tel: +44 (0)1224 725999
Email: ab@able.co.uk

Internet: www.able.co.uk
e-procurement: www.247able.com
Registered in England No: 01851002
VAT No: GB 417 2481 61



Table of Contents

	Section	Page
Section 1 - General		
Introduction	1.1	1
Principles Of Operation	1.2	1
Reshaping The Velocity Profile	1.3	1
Section 2 - Features		
High Accuracy	2.1	2
Repeatability	2.2	2
Turndown	2.3	2
Installation Requirements	2.4	3
Long Term Performance	2.5	3
Signal Stability	2.6	3
Low Permanent Pressure Loss	2.7	3
Sizing	2.8	4
No Areas of Stagnation	2.9	4
Mixing	2.10	4
V-Cone Flow Meter Models	2.11	4
Section 3 - The V-Cone Flow Meter Measurement System		
Application Data	3.1	5
Flow Calculations	3.2	5
Simplified Liquid Calculations	3.3	7
Application Sizing	3.4	8
Calibration	3.5	8
Materials Of Construction	3.6	8
Valve Manifolds	3.7	8
Secondary And Tertiary Instrumentation	3.8	9
Appendices		
V-Cone flow meter Installation Guide Upstream and Downstream Minimum Straight Pipe Run Requirements for Gas Metering at a Reynolds Number (Re) Value > 200,000		10
V-Cone flow meter Installation Guide Upstream and Downstream Minimum Straight Pipe Run Requirements for Liquid Metering and Gases at a Reynolds Number (Re) Value Less Than or Equal To 200,000		11
Warranty		12



1.0

General

1.1 Introduction

The McCrometer V-Cone® Flow meter is a patented technology that accurately measures flow over a wide range of Reynolds numbers, under all kinds of conditions and for a variety of fluids. It operates on the same physical principle as other differential pressure-type flowmeters, using the theorem of conservation of energy in fluid flow through a pipe. The V-Cone's remarkable performance characteristics, however, are the result of its unique design. It features a centrally-located cone inside the tube. The cone interacts with the fluid flow, reshaping the fluid's velocity profile and creating a region of lower pressure immediately downstream of itself. The pressure difference, exhibited between the static line pressure and the low pressure created downstream of the cone, can be measured via two pressure sensing taps. One tap is placed slightly upstream of the cone, the other is located in the downstream face of the cone itself. The pressure difference can then be incorporated into a derivation of the Bernoulli equation to determine the fluid flow rate. The cone's central position in the line optimizes the velocity profile of the flow at the point of measurement, assuring highly accurate, reliable flow measurement regardless of the condition of the flow upstream of the meter.

1.2 Principles Of Operation

The V-Cone flow meter is a differential pressure type flowmeter. Basic theories behind differential pressure type flowmeters have existed for over a century. The principal theory among these is Bernoulli's theorem for the conservation of energy in a closed pipe. This states that for a constant flow, the pressure in a pipe is inversely proportional to the square of the velocity in the pipe. Simply, the pressure decreases as the velocity increases. For instance, as the fluid approaches the V-Cone flow meter, it will have a pressure of P_1 . As the fluid velocity increases at the constricted area of the V-Cone, the pressure drops to P_2 , as shown in Figure 1.

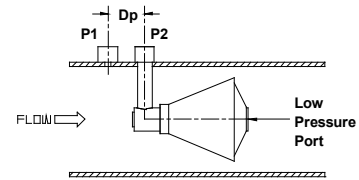

High and Low Ports
Figure 1

Both P_1 and P_2 are measured at the V-Cone flow meter's taps using a variety of differential pressure transducers. The Dp created by a V-Cone flow meter will increase and decrease exponentially with the flow velocity. As the constriction takes up more of the pipe cross-sectional area, more differential pressure will be created at the same flowrates. The beta ratio equals the flow area at the largest cross section of the cone (converted to an equivalent diameter) divided by the meter's inside diameter (see 3.2.1).

1.3 Reshaping The Velocity Profile

The V-Cone flow meter is similar to other differential pressure (Dp) meters in the equations of flow that it uses. V-Cone flow meter geometry, however, is quite different from traditional Dp meters. The V-Cone constricts the flow by positioning a cone in the center of the pipe.

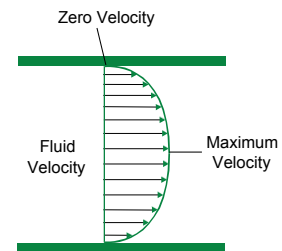

Velocity Profile
Figure 2

This forces the flow in the center of the pipe to flow around the cone. This geometry presents many advantages over the traditional concentric Dp meter. The actual shape of the cone has been continuously evaluated and tested for over ten years to provide the best performance under differing circumstances.

One must understand the idea of a flow profile in a pipe to understand the performance of the V-Cone flow meter. If the flow in a long pipe is not subject to any obstructions or disturbances, it is well-developed flow. If a line passes across the diameter of this well-developed flow, the velocity at each point on that line would be different. The velocity would be zero at the

V-CONE®

wall of the pipe, maximum at the center of the pipe, and zero again at the opposite wall. This is due to friction at the pipe walls that slows the fluid as it passes. Since the cone is suspended in the center of the pipe, it interacts directly with the “high velocity core” of the flow. The cone forces the high velocity core to mix with the lower velocity flows closer to the pipe walls. Other Dp meters have centrally located openings and do not interact with this high velocity core. This is an important advantage to the V-Cone at lower flowrates. As the flowrate decreases, the V-Cone continues to interact with the highest velocity in the pipe. Other Dp meters may lose their useful Dp signal at flows where the V-Cone can still produce one.

The pipe flow profile in actual installations is rarely ideal. There are many installations where a flowmeter exists in flow that is not well developed. Practically any changes to the piping, such as elbows, valves, reductions, expansions, pumps, and tees can disturb well-developed flow. Trying to measure disturbed flow can create substantial errors for other flowmeter technologies. The V-Cone flow meter overcomes this by reshaping the velocity profile upstream of the cone. This is a benefit derived from the cone’s contoured shape and position in the line. As the flow approaches the cone, the flow profile “flattens” toward the shape of a well-developed profile.

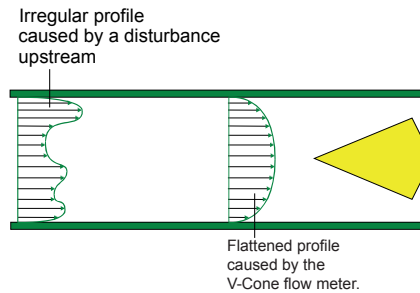

Flattened Velocity Profile
Figure 3

The V-Cone flow meter can flatten the flow profile under extreme conditions, such as a single elbow or double elbows out-of-plane, positioned closely upstream of the meter. This means that as different flow profiles approach the cone, there will always be a predictable flow profile at the cone. This ensures accurate measurement even in non-ideal conditions.

2.0 Features

2.1 High Accuracy

The V-Cone flow meter primary element can be accurate to $\pm 0.5\%$ of reading and the Wafer-Cone® can be accurate to $\pm 1.0\%$. The level of accuracy is dependent to a degree on application parameters and secondary instrumentation.

2.2 Repeatability

The V-Cone flow meter and the Wafer-Cone flow meter primary element exhibits excellent repeatability of $\pm 0.1\%$ or better.

2.3 Turndown

The turndown of the V-Cone flow meter can reach far beyond traditional Dp meters. A typical turndown for a V-Cone flow meter is 10 to 1. Greater turndowns are attainable. Flows with Reynolds numbers as low as 8000 will produce a linear signal. Lower Reynolds number ranges are measurable and are repeatable by applying a curve fit to the measured Dp, derived from calibration over a specific Reynolds number range.

V-CONE®

2.4 Installation Requirements

Since the V-Cone flow meter can flatten the velocity profile, it can function much closer to upstream disturbances than other Dp meters. The recommended installation for the V-Cone flow meter is zero to three diameters of straight run upstream and zero to one diameters downstream. This can be a major benefit to users with larger, more expensive line sizes or users which have small run lengths. McCrometer conducted performance tests of the V-Cone downstream of a single 90° elbow and two close coupled 90° elbows out of plane. These tests show that the V-Cone flow meter can be installed adjacent to either single elbows or two elbows out of plane without sacrificing accuracy. For specific installation recommendations, see appendices.

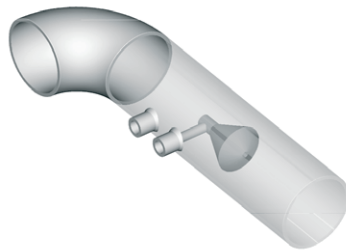

Single Elbow and V-Cone flow meter
Figure 4

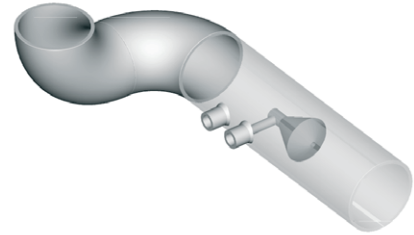

Double Elbow and V-Cone Flow Meter
Figure 5

2.5 Long Term Performance

The contoured shape of the cone constricts the flow without impacting the flow against an abrupt surface. A boundary layer forms along the cone and directs the fluid away from the beta edge. This means the beta edge will not be as subject to the usual wear by unclean fluids, as is the case with an orifice plate. The beta ratio will then remain unchanged and the calibration of the meter will be accurate for a much longer time.

2.6 Signal Stability

Every Dp meter has a "signal bounce". This means that even in steady flow, the signal generated by the primary element will fluctuate a certain amount. On a typical orifice plate, the vortices that form just after the plate are long. These long vortices create a high amplitude, low frequency signal from the orifice plate. This could disturb the Dp readings from the meter. The V-Cone forms very short vortices as the flow passes the cone. These short vortices create a low amplitude, high frequency signal. This translates into a signal with high stability from the V-Cone. Representative signals from a V-Cone flow meter and from a typical orifice plate are shown in figure 6.

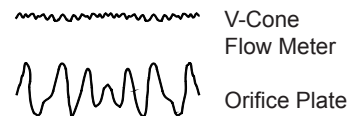

Signal Stability
Figure 6

2.7 Low Permanent Pressure Loss

Without the impact of an abrupt surface, the permanent pressure loss is lower than a typical orifice plate meter. Also, the signal stability of the V-Cone flow meter allows the recommended full scale Dp signal to be lower for the V-Cone flow meter than other Dp meters. This will lower the permanent

V-CONE®

pressure loss.

2.8 Sizing

The unique geometry of the V-Cone flow meter allows for a wide range of beta ratios. Standard beta ratios range from 0.45, 0.55, 0.65, 0.75, and 0.80.

2.9 No Areas of Stagnation

The “swept through” design of the cone does not allow for areas of stagnation where debris, condensation or particles from the fluid could accumulate.

2.10 Mixing

The short vortices described in section 2.6 mix the fluid thoroughly just downstream of the cone. The V-Cone flow meter is currently used in many applications as a static mixer where instant and complete mixing are necessary.

2.11 V-Cone Flow Meter Models

McCrometer offers two types of V-Cone flow meter primary elements: the precision tube V-Cone and the Wafer-Cone flow meters. Precision tube V-Cone flow meters range in line sizes from ½” to 72” and larger and Wafer-Cone flow meters range from 1” to 6”.

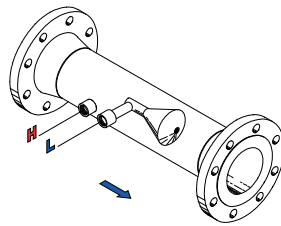

**Precision Tube
V-Cone Flow Meter
Figure 7**

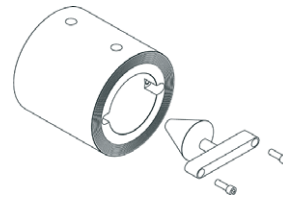

**Wafer-Cone Flow Meter
Figure 8**



3.0

The V-Cone Flow Meter Measurement System

3.1 Application Data

The customer must provide application parameters so that the appropriate V-Cone flow meter may be selected. McCrometer has an extensive meter performance database of fluid properties which can be utilized for sizing purposes.

3.2 Flow Calculations

Nomenclature (All references to "V-Cone" are to the V-Cone flow meter.)

Symbol	Description	English Units	Metric Units
α	Material Thermal Expansion α or α_{cone} , α_{pipe} (alpha)	$^{\circ}\text{R}^{-1}$	$^{\circ}\text{R}^{-1}$
β	Beta Ratio	-	-
C_D	Flowmeter Coefficient	-	-
d	Cone Outside Diameter	in	mm
D	Pipe Inside Diameter	in	mm
ΔP	Differential Pressure (dp)	inWC	mbar
ΔP_{max}	Maximum Differential Pressure on Sizing	See note 4	See note 4
F_a	Material Thermal Expansion Factor	-	-
k	Gas Isentropic Exponent	-	-
k_1	Flow Constant	$\sqrt{\frac{\text{lbm} \cdot \text{ft}^3}{\text{s}^2 \cdot \text{inWC}}}$	$\sqrt{\frac{\text{kg} \cdot \text{m}^3}{\text{s}^2 \cdot \text{mbar}}}$
k_2	Simplified Liquid Flow Constant	See note 4	See note 4
μ	Viscosity	cP	cP
P	Operating Pressure	psiA	barA
P_b	Base Pressure	psiA	barA
Q	Actual Volume Flow	ACFS	m^3/s
Q_{max}	Maximum Flowrate on Sizing	See note 4	See note 4
Q_{STD}	Standard Gas Volume Flow	SCFS	Nm^3/s
Re	Reynolds Number	-	-
ρ	Flowing Density (rho)	lbm/ft^3	kg/m^3
ρ_{water}	Water Density	62.3663 lbm/ft^3	999.012 kg/m^3
S_g	Specific Gravity of the Gas	-	-
S_L	Specific Gravity of the Liquid	-	-
T	Operating Temperature	$^{\circ}\text{R}$	K
T_b	Base Temperature	$^{\circ}\text{R}$	K
T_d	Deviation from Standard Temperature ($^{\circ}\text{R}$)	$T_d = T - 527.67$	$T_d = \frac{9}{5}T - 527.67$
U_1	Unit Conversion	0.0360912 psiA/inWC	0.001 barA/mbar
U_2	Unit Conversion	144 in^2/ft^2	1,000,000 mm^2/m^2
U_3	Unit Conversion	167.213 $\text{lbm}/\text{s}^2 \text{ft inWC}$	100 $\text{kg}/\text{m}^2 \text{s}^2 \text{mbar}$
U_4	Unit Conversion	124.0137 cP ft s / lbm	1
U_5	Unit Conversion	2.6988 $^{\circ}\text{R lbm} / \text{ft}^3$ psiA	348.338 K kg / m^3 barA
v	Velocity	ft/s	m/s
Y	Gas Expansion Factor	-	-
Z	Gas Compressibility	-	-
Z_b	Base Gas Compressibility	-	-

V-CONE®

General Flow Calculations (All references to "V-Cone" are to the V-Cone flow meter.)

3.2.1	V-Cone Beta Ratio	$\beta = \sqrt{1 - \frac{d^2}{D^2}}$	β from sizing report
3.2.2	Flow Constant	$k_1 = \frac{\pi \cdot \sqrt{2} \cdot U_3}{4 \cdot U_2} \cdot \frac{D^2 \cdot \beta^2}{\sqrt{1 - \beta^4}}$	
3.2.3	Material Thermal Expansion Factor	$F_a = 1 + 2 \cdot \alpha \cdot T_d$	See note 1.
3.2.4	Material Thermal Expansion Factor If cone and main pipe are made of different materials	$F_a = \frac{D^2 - d^2}{[(1 - \alpha_{pipe} \cdot T_d) \cdot D]^2 - [(1 - \alpha_{cone} \cdot T_d) \cdot d]^2}$	See note 1.
3.2.5	Pipeline Velocity	$v = \frac{4 \cdot U_2 \cdot Q}{\pi \cdot D^2}$	
3.2.6	Reynolds Number	$Re = U_4 \frac{v \cdot D \cdot \rho}{\mu}$	Dimensionless number which can be used to correlate meter calibration in different fluids
3.2.7	V-Cone Gas Expansion Factor	$Y = 1 - (0.649 + 0.696 \cdot \beta^4) \frac{U_1 \cdot \Delta P}{k \cdot P}$	For Liquids Y = 1
3.2.8	Wafer Gas Expansion Factor	$Y = 1 - (0.755 + 6.78 \cdot \beta^8) \frac{U_1 \cdot \Delta P}{k \cdot P}$	For Liquids Y = 1
3.2.9	Liquid Density	$\rho = \rho_{water} \cdot S_L$	
3.2.10	Gas Density	$\rho = U_5 \frac{S_g \cdot P}{Z \cdot T}$	
3.2.11	Actual Volume Flowrate	$Q = F_a \cdot C_D \cdot Y \cdot k_1 \cdot \sqrt{\frac{\Delta P}{\rho}}$	See notes 2, 3 & 5
3.2.12	Standard Gas Volume Flowrate	$Q_{STD} = Q \cdot \left(\frac{P \cdot T_b \cdot Z_b}{P_b \cdot T \cdot Z} \right)$	Converts actual flow to standard flow at base conditions

√CONE[®]

3.3 Simplified Liquid Calculation

3.3.1	Simplified Liquid Flow Constant	$k_2 = \frac{Q_{\max}}{\sqrt{\Delta P_{\max}}}$	See note 4
3.3.2	Simplified Liquid Flowrate	$Q = k_2 \sqrt{\Delta P}$	See note 4

Notes:

1. Material Thermal Expansion – The thermal expansion equations correct for dimensional changes which occur as the operating temperature deviates from the base temperature of 68° F (see 3.2.3 and 3.2.4) The F_a factor can be excluded from the flow equation if the operating temperature is:

< 100° Fahrenheit , < 559.67° Rankine , < 37.78° Celsius, < 310.93 K.

If the F_a factor is significant and the operating temperature is stable then a constant F_a value can be used. If the F_a factor is significant and the temperature varies then an F_a factor should be calculated prior to every flow calculation.

2. Discharge Coefficient – Discharge coefficients can be implemented in the flow equations via several different methods. Typical methods are average C_D , C_D look up table, or C_D fitted data. If a C_D look up table or fitted data is utilized additional calculations must be made based on the Reynolds number (see example process 3d and 5b).

3. Liquid – Typical Calculation Process

- a. Given: D, β , ρ , C_D , and input of ΔP
Calculate: 3.2.2, 3.2.11
- b. Given: D, β , ρ , C_D , and input of ΔP , T
Calculate: 3.2.2, 3.2.3 or 3.2.4 if req., 3.2.11
- c. Given: D, β , S_p , C_D , and input of ΔP , T
Calculate: 3.2.2, 3.2.3 or 3.2.4 if req., 3.2.9, 3.2.11
- d. Given: D, β , μ , ρ , C_D look up, and input of ΔP
Calculate: initially set $C_D = 0.8$, 3.2.2, 3.2.3 or 3.2.4 if req., 3.2.11

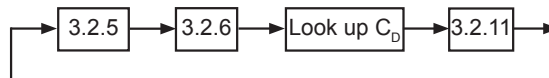

Iterate until flowrate is <0.01% different from last calculation

4. Simplified Liquid Calculation – The simplified liquid calculation can be used if the operating temperature is stable and the C_D is constant. The simplified flow constant (k_2) can be calculated from equation 3.3.1 using the V-Cone Flow Meter Application Sizing sheet. The flowrate can then be calculated using equation 3.3.2. Units of measure will be the same as those listed on the V-Cone Flow Meter Application Sizing sheet.

5. Gases and steam – Typical Calculation Process:

- a. Given: D, β , μ , S_g , Z, k, C_D , and inputs of ΔP , P, T
Calculate: 3.2.2, 3.2.3 or 3.2.4 if req., 3.2.7 or 3.2.8, 3.2.10, 3.2.11
- b. Given: D, β , μ , S_g , Z, k, C_D look up, and inputs of ΔP , P, T
Calculate: initially set $C_D=0.8$, 3.2.2, 3.2.3 or 3.2.4 if req., 3.2.7 or 3.2.8, 3.2.10, 3.2.11

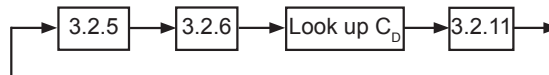

Iterate until flowrate is <0.01% different from last calculation

V[√]CONE[®]

6. Fluid Properties – Fluid properties such as velocity, compressibility and isentropic exponent vary with temperature and to some extent pressure. The viscosity in the calculations above could effect the selected C_D value, the compressibility directly effects the density and the isentropic exponent effects the Y factor, although to a small degree. The instrumentation industry uses many different approaches to calculate flow. McCrometer application engineering and the customer must determine which fluid properties are calculated at each set of flow conditions and which properties are constant.

3.4 Application Sizing

Each V-Cone flow meter is tailored to its specific application. Before manufacturing, every V-Cone flow meter will have a “sizing” completed according to the physical parameters of the application. The computer generated sizing uses application data as a basis to predict the V-Cone flow meter’s performance. Full scale DP, working flow range, expected accuracy, and predicted pressure loss are determined by the sizing process.

3.5 Calibration

McCrometer has 4 test lines and can calibrate meters from 1/2” to 48” with a high degree of accuracy.

Test Lines:

Location	Type	Size Range	Flow Range	Fluid
Hemet, CA	Gravimetric	1/2” to 3”	195 GPM	Water
Hemet, CA	Gravimetric	3” to 16”	3100 GPM	Water
Hemet, CA	Transfer Standard	1/2” to 2”	150 SCFM	Air
Porterville, CA	Volumetric	16” to 48”	40,000 GPM	Water

McCrometer recommends calibration of every V-Cone flow meter. Optimal accuracy is achieved when a full flow range calibration is performed. In high Reynolds number applications this may require an outside gas calibration. As an alternative, McCrometer has developed a proprietary method to accurately extrapolate flow calibration data. In cases where the meter can not be calibrated McCrometer can estimate the meter C_f based on 20 plus years of data.

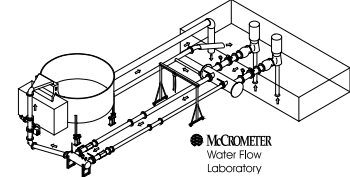

Calibration Facility 40k Gravimetric Figure 9

3.6 Materials Of Construction

All materials used for V-Cone flow meters are certified. Materials furnished to McCrometer include a certified material test report (CMTR) from the original material manufacturer. The test reports include material composition and applicable material grades. Upon request copies of the material test reports can be supplied to our customers. See section 6.5 for typical materials of construction.

3.7 Valve Manifolds

McCrometer recommends a three valve or five valve manifold as part of a V-Cone flow meter measurement system. Manifolds allow for in-line transmitter calibrations, isolation of the transmitter from the transmission lines, without depressurizing the line, and in-line purging of transmission lines.

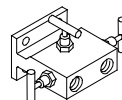
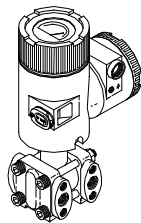

Figure 10



3.8 Secondary And Tertiary Instrumentation

A differential pressure transmitter measures the differential pressure signal from the primary element. Once the signal is measured, the transmitter generates an electronic signal that is then interpreted by a flow monitor or other process control system. For compressible fluids, line pressure and temperature measurements are generally required for accurate flow measurement. McCrometer offers the following flow measurement instrumentation: differential pressure transmitters, flow computers, and pressure and temperature sensors for mass flow measurement.



**Typical Dp Trans.
Figure 11**

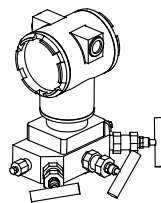

**Typ. Dp Trans.
with valve manifold
Figure 12**

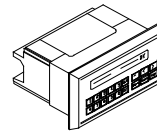

**Flow Computer
Figure 13**

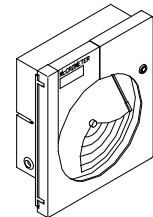

**Chart Recorder
Figure 14**



V-Cone Flow Meter Installation Guide Upstream and Downstream Minimum Straight Pipe Run Requirements

For Gas Metering at a
Reynolds Number (Re) Value > 200,000

For β greater than or equal to 0.70 add 1D

Size Range	Obstruction	Up Stream	Down Stream
All Sizes	1 Elbow	1D	1D
	2 Elbows	1D	1D
	Tees	1D	1D
	Butterfly Valve (control valve)	Not Preferred Position	Valve Downstream 1D
	Butterfly Valve (shutoff valve)	2D	1D
	Full port Ballvalve (shutoff)	1D	1D
	Heat Exchanger (Depends on Type)	1D	0D
	Expander (0.67D to D) over a length of 2.5D	2D	1D
	Reducer (3D to D) over a length of 3.5D	0D	0D

Note: The meter and adjoining pipe should have equal IDs.



V-Cone Flow Meter Installation Guide Upstream and Downstream Minimum Straight Pipe Run Requirements

For Liquid Metering and Gases at a
Reynolds Number (Re) Value Less Than or Equal To 200,000

For β greater than or equal to 0.70 add 1D

Size Range	Obstruction	Up Stream	Down Stream
All Sizes	1 Elbow	0D	0D
	2 Elbows	0D	0D
	Tees	0D	0D
	Butterfly Valve (control valve)	Not Preferred Position	Valve Downstream 1D
	Butterfly Valve (shutoff valve)	2D	0D
	Full port Ballvalve (shutoff)	0D	0D
	Heat Exchanger (Depends on Type)	0D	0D
	Expander (0.67D to D) over a length of 2.5D	2D	1D
	Reducer (3D to D) over a length of 3.5D	0D	0D

Note: The meter and adjoining pipe should have equal IDs.



MANUFACTURER'S WARRANTY

This Warranty shall apply to and be limited to the original purchaser consumer of any McCrometer product. Meters or instruments defective because of faulty material or workmanship will be repaired or replaced, at the option of McCrometer, Inc., free of charge, FOB the factory in Hemet, California, within a period of one (1) year from the date of delivery.

Repairs or modifications by others than McCrometer, Inc. or their authorized representatives shall render this Warranty null and void in the event that factory examination reveals that such repair or modification was detrimental to the meter or instrument. Any deviations from the factory calibration require notification in writing to McCrometer, Inc. of such recalibrations or this warranty shall be voided.

In case of a claim under this Warranty, the claimant is instructed to contact McCrometer, Inc. 3255 West Stetson Ave., Hemet, California 92545, and to provide an identification or description of the meter or instrument, the date of delivery, and the nature of the problem.

The Warranty provided above is the only warranty made by McCrometer, Inc. with respect to its products or any parts thereof and is made expressly in lieu of any other warranties, by course of dealing, usages of trade or otherwise, expressed or implied, including but not limited to any implied warranties of fitness for any particular purpose or of merchantability under the uniform commercial code. It is agreed this warranty is in lieu of and buyer hereby waives all other warranties, guarantees or liabilities arising by law or otherwise. Seller shall not incur any other obligations or liabilities or be liable to buyer, or any customer of buyer for any anticipated or lost profits, incidental or consequential damages, or any other losses or expenses incurred by reason of the purchase, installation, repair, use or misuse by buyer or third parties of its products (including any parts repaired or replaced); and seller does not authorize any person to assume for seller any other liability in connection with the products or parts thereof. This Warranty cannot be extended, altered or varied except by a written instruction signed by seller and buyer.

This Warranty gives you specific legal rights, and you may also have other rights which vary from state to state.

McCrometer, Inc. reserves the right to make improvements and repairs on product components which are beyond the warranty period at the manufacturer's option and expense, without obligation to renew the expired warranty on the components or on the entire unit. Due to the rapid advancement of meter design technology, McCrometer, Inc. reserves the right to make improvements in design and material without prior notice to the trade.

All sales and all agreements in relation to sales shall be deemed made at the manufacturer's place of business in Hemet, California and any dispute arising from any sale or agreement shall be interpreted under the laws of the State of California.

Reading Office

Cutbush Park, Danehill, Lower Earley,
Reading, Berkshire. RG6 4UT. UK.
Tel: +44 (0)118 9311188
Email: info@able.co.uk









Aberdeen Office

Unit 6 Airside Business Park, Kirkhill Industrial Estate,
Dyce, Aberdeen. AB21 0GT. UK.
Tel: +44 (0)1224 725999
Email: ab@able.co.uk

Internet: www.able.co.uk
e-procurement: www.247able.com
Registered in England No: 01851002
VAT No: GB 417 2481 61



OTHER McCROMETER PRODUCTS INCLUDE:

	Magnetic Flowmeters
	Magnetic Flowmeters
	Magnetic Flowmeters
	Propeller Flowmeters
	Remote Telemetry System
	Propeller Flowmeters
	Differential Pressure Flowmeters
	Differential Pressure Flowmeters
	Differential Pressure Flowmeters

May be covered by one or more patents, including U.S. Patents 5363699 and 5,814,738 and counterparts outside the U.S.; other U.S. and foreign patents pending.